

RESEARCH ACTIVITIES

Graduate School of Medicine
The University of Tokyo

March 2003

**Assembled and Edited by
the Planning Committee for External Review**

Hiroto Okayama
Nobutaka Hirokawa
Ryozo Nagai
Hirokazu Nagawa
Hiroshi Kurita
Susumu Wakai

Preface

The University of Tokyo Faculty of Medicine was established in 1877, under Japan's modernizing Meiji government. Its roots go back to the vaccination center established with donations from 82 private practitioners in 1858, when Tokyo was still called Edo, and over the past 145 years it has trained some 20,000 doctors.

While we are conscious and proud of our long tradition, we are acutely aware of the need to reform our curriculum to meet the needs of a new age. We are determined to prepare our students to become tomorrow's leaders in international medicine through the best possible undergraduate training.

So it is too in the realm of research, where we intend to uphold the highest standards to solve the most challenging problems. For many years we have worked to consolidate and improve our strengths in this area.

The 1991 revision of Japan's Standards for University Establishment called on universities to examine and evaluate their own performance. Internal reviews have begun at many universities. The newly established National Institution for Academic Degrees began reviewing Japan's universities in 2000.

In undergraduate education, we now regularly carry out evaluations of our own programs, including through course evaluations by students. Formerly in research, we evaluated our work by publishing biannual lists of each department's publications; we are taking steps to ensure that our evaluation will be more objective and rigorous in the future.

The designation in 1997 of the University of Tokyo as an institution centered on its graduate schools was a turning point. It is vital that we give the future development of postgraduate education here a sound foundation. Universities must see themselves as they are seen by others. Hence the present external evaluation of our research programs.

Research, teaching, and clinical practice are of course closely linked in a graduate school of medicine, and all three require evaluation, yet this time, we restricted our scope to research. Needless to say, this can under no circumstances be construed as the relegation of teaching and clinical practice to ancillary roles. Simply, we hoped to receive the most useful possible suggestions by narrowing our area of focus. Research is of course, by itself, a vast field.

The review process was meticulously prepared and executed by a committee headed by Professor Hiroto Okayama. We invited world-renowned scientists of the highest caliber to serve on the committee and review our faculty's work. Professor Erwin Neher and nine other distinguished scientists from overseas worked in collaboration with eleven eminent colleagues from Japan. I wish here to express my sincere gratitude to the evaluation team, who devoted so much of their valuable time to this task.

Whether internal or external, the principal meaning of any review lies in the willingness of those reviewed to listen and respond to fair criticism. Without vigorous implementation of changes -- should any be shown to be necessary -- external review will be sterile.

Greater openness is yet another major aim. Through outside evaluation we hope to make our research activities as widely known as possible and to arouse the public's interest in our work by publicizing both our findings and the outcome of peer review. Exposure to outside scrutiny and a wider audience will encourage us to reflect on future directions.

I earnestly hope that the findings of this external evaluation will, in these and many other ways, be a powerful guiding force helping us to build better research structures and programs at the University of Tokyo.

March 2003

A handwritten signature in black ink that reads "Takaaki Kirino". The signature is written in a cursive, flowing style.

Takaaki Kirino, MD, PhD
Dean, Graduate School and
Faculty of Medicine
The University of Tokyo

CONTENTS

Preface	<3>
Planning and Implementation of the External Review	<7>
Report of the External Review	
Executive Summary	<15>
Group Summaries	
Group 1	<21>
Group 2	<25>
Group 3	<29>
Group 4	<35>
Research Activities	
Graduate School of Medicine, The University of Tokyo	1
February 2003	

Planning and Implementation of the External Review

In April 2002, on the decision of Dean Takaaki Kirino and with the agreement of senior faculty members, a planning committee for external review was formed. The planning committee comprised Professors Nobutaka Hirokawa, Ryozo Nagai, Hirokazu Nagawa, Hiroshi Kurita, Susumu Wakai, and myself. We began designing the structure of the external review and selecting the reviewers. The purpose of the external review was to obtain information that would help us improve our research activities and maintain them at the highest international level. All senior faculty members chairing departments in the Graduate School of Medicine were subject to review; they were asked to prepare descriptions of the research activities of their group, providing a list of the current members of the department, an outline of the department's past and current research, descriptions of up to five major research grants obtained in the past five years, and a list of no more than 50 of the best papers published by the group. These documents were assembled and edited by the planning committee and printed as a single volume. In addition, all reviewees were asked to provide copies of their ten most important papers.

The committee of reviewers comprised 21 experts of high international repute, 11 from Japan and 10 from other countries, headed by Professor Erwin Neher. (The committee members are listed on page 8.) The reviews covered activities in all areas of research, from basic and clinical medicine to public health and nursing. Each reviewee was reviewed by the two most appropriate reviewers, one from Japan and one from another country. In December 2002, each reviewer received a copy of the bound volume outlining research activities, copies of the ten most important papers of their reviewees, and instructions regarding the procedures and scope of the evaluation. Each reviewer was requested to begin an in-depth examination of their reviewees' research activities, on the basis of these materials. On February 18 and 19, 2003, the external review committee visited the Graduate School of Medicine to hear presentations by all reviewees and to make their final evaluations. The presentations were grouped into four areas: basic medicine, internal medicine and related fields, surgical sciences, and social medicine and nursing. Presentations in the four areas were given in parallel in the Medical Research and Teaching Building, as shown in the schedule on page 10.

All evaluations were collected at the end of the visit, and were sent immediately to Professors Ito in Group 1, Saruta in Group 2, Kakita in Group 3, and Aoki in Group 4, who were asked to prepare summaries for their groups, and to Professor Neher, who prepared the executive summary. The summaries are published here.

Hiroto Okayama, MD, PhD
Chair
Planning Committee for External Review

Alphabetical List of External Reviewers

Aoki, Yoshiki MD & PhD	Professor, Chairman and Director Nagasaki University, Institute of Tropical Medicine, Japan "Parasitology"
Holzemer, William L. RN, PhD, FAAN	Professor, Chair and Associate Dean for International Programs Department of Community Health Systems, School of Nursing, University of California San Francisco, USA "AIDS Nursing Care"
Ito, Masao MD & PhD	Director Brain Science Institute, RIKEN, Japan "Brain"
Julien, Jean Pierre PhD	Professor Department of Neurology, McGill University Faculty of Medicine, Canada "Neuronal Intermediate Filaments and Amyotrophic Lateral Sclerosis"
Kakita, Akira MD & PhD	Professor, Chairman and Hospital Director Department of Surgery, Kitazato University School of Medicine, Japan "Gastrointestinal Surgery and Liver Transplantation"
Kakizoe, Tadao MD & PhD	President National Cancer Center, Japan "Urology and Bladder Cancer"
Kitamura, Yukihiro MD & PhD	Professor and Chairman Department of Pathology, Osaka University Medical School, Japan "Hematopoiesis, Hematopoietic Stem Cell and Tumor"
McCarley, Robert William MD	Professor and Head Department of Psychiatry, Harvard Medical School, USA "Neurobiology and Behavior: Basic Sleep Research & Brain Imaging in Schizophrenia"
McGarvey, Stephen PhD	Professor of Community Health and Director of International Health Institute Brown University Medical School, USA "Human Population Biology and International Health"
Neher, Erwin PhD	Professor and Director The Membrane Biophysics Department, The Max-Planck-Institut für biophysikalische Chemie, Germany "Patch Clamp and Exocytosis"
Nilsson, Kenneth PhD & MD	Professor Department of Cellular Pathology, University of Uppsala, Sweden "Immunology, Tumor Biology and Virology"

Nozawa, Shiro MD & PhD	Professor and Chairman Department of Obstetrics and Gynecology, School of Medicine, Keio University, Japan "Gynecologic Cancer"
Ogihara, Toshio MD & PhD	Professor, Chairman and Hospital Vice-Director Department of Geriatric Medicine, Osaka University Medical School, Japan "Hypertension"
Park, Jae-Gahb MD & PhD	Professor Department of Surgery, Seoul National University College of Medicine President National Cancer Center, Korea "Surgical Oncology"
Podolsky, Daniel K. MD	Mallinckrodt Professor of Medicine Harvard Medical School, Massachusetts General Hospital, USA "Hormonal Signaling in the Gastrointestinal Tract"
Saruta, Takao MD & PhD	Professor and Chairman Department of Internal Medicine, School of Medicine, Keio University, Japan "Hypertension, Adrenal Disorders and Water-Electrolyte Balance"
Schmelzeisen, Rainer MD & DDS	Professor and Chairman Oral and Maxillofacial Surgery, Plastic Surgery, University- Clinic Freiburg Albert-Ludwigs-University, Germany "Bone Metabolism and Cancer"
Sonenberg, Nahum PhD	Professor Department of Biochemistry and McGill Cancer Center, McGill University Faculty of Medicine, Canada "Eukaryotic Translation Control"
Toyoshima, Kumao MD & PhD	Director SNP Research Center, RIKEN, Japan "Cancer Biology and Virology"
Tsumoto, Tadaharu MD & PhD	Professor and Chairman Department of Neurophysiology, Osaka University, Graduate School of Medicine, Japan "Neurophysiology and Optical Center"
Ueda, Reiko PhD	President Okinawa Prefectural Collage of Nursing, Japan "Child Health Nursing"

Schedule of External Review Presentation

Feb. 17								
9:00-9:20	Introduction of reviewers (Tetsumon Memorial Hall)							
	Group 1 Room 1305		Group 2 Room 1304B		Group 3 Room 1303		Group 4 Room 1302	
	Speakers	Reviewers	Speakers	Reviewers	Speakers	Reviewers	Speakers	Reviewers
9:30-10:00	Takao Shimizu, Cellular Signaling	Jean Pierre Julien Tadaharu Tsumoto	Satoshi Kimura, Infection Control & Prevention	Daniel K. Podolsky Takao Saruta	Yuji Taketani, Obstetrics & Gynecology	Rainer Schmelzeisen Shiro Nozawa	Yasuki Kobayashi, Public Health	Stephen McGarvey Yoshiki Aoki
10:00-10:30	Hiroto Okayama, Molecular Biology	Nahum Sonenberg Kumao Toyoshima	Kuni Ohtomo, Radiology	Daniel K. Podolsky Takao Saruta	Osamu Tsutsumi, Gynecologic Surgery	Rainer Schmelzeisen Shiro Nozawa	Kazuhiro Ohe, Medical Informatics and Economics	Stephen McGarvey Yoshiki Aoki
10:30-11:00	Nobutaka Hirokawa, Cell Biology & Anatomy	Jean Pierre Julien Tadaharu Tsumoto	Nobumasa Kato, Neuropsychiatry	Robert W. McCarley Toshio Ogihara	Kohei Hashizume, Pediatric Surgery	Tadashi Kakizoe Akira Kakita	Hiroshi Kurita, Mental Health	William L. Holzemer Reiko Ueda
	Coffee break (20min)							
11:20-11:50	Hiroki Kurihara, Physiological Chemistry	Jean Pierre Julien Tadaharu Tsumoto	Shoji Tsuji, Neurology	Robert W. McCarley Toshio Ogihara	Shinichi Takamoto, Cardiothoracic Surgery	Jae-Gahb Park Tadao Kakizoe	Ichiro Kai, Social Gerontology	William L. Holzemer Reiko Ueda
11:50-12:20	Yasushi Miyashita, Integrative Physiology & Metabolism	Erwin Neher Masao Ito	Kazuhiro Yamamoto, Allergy and Rheumatology	Daniel K. Podolsky Takao Saruta	Michio Kaminishi, Gastrointestinal Surgery	Jae-Gahb Park Tadao Kakizoe	Akira Akabayashi, Health Economics/Health Promotion Science/ Biomedical Ethics	William L. Holzemer Reiko Ueda
12:20-12:50	Kensaku Mori, Cellular & Molecular Physiology	Erwin Neher Masao Ito	Masao Omata, Gastroenterology	Daniel K. Podolsky Takao Saruta	Masatoshi Makuuchi, Hepato-Biliary- Pancreatic Surgery	Jae-Gahb Park Tadao Kakizoe	Yasuo Ohashi, Biostatistics/Epidemiology Epidemiology & Preventive Health Sciences	William L. Holzemer Reiko Ueda
	Lunch (70min)							
14:00-14:30	Tomoyuki Takahashi, Neurophysiology	Erwin Neher Masao Ito	Toshiro Fujita, Nephrology and Endocrinology	Daniel K. Podolsky Takao Saruta	Tadaichi Kitamura, Urology	Jae-Gahb Park Akira Kakita	Katsuya Kanda, Advanced Clinical Nursing/ Nursing Administration	William L. Holzemer Reiko Ueda
14:30-15:00	Masamitsu Iino, Cellular & Molecular Pharmacology	Erwin Neher Masao Ito	Ryoza Nagai, Cardiovascular Medicine	Daniel K. Podolsky Takao Saruta	Hirokazu Nagawa, Surgical Oncology	Jae-Gahb Park Tadao Kakizoe	Keiko Kazuma, Adult Nursing/ Terminal & Long-term Care Nursing	William L. Holzemer Reiko Ueda
15:00-15:30	Masayoshi Mishina, Molecular Neurobiology	Erwin Neher Masao Ito	Tomifusa Kuboki, Psychosomatic Medicine	Robert W. McCarley Toshio Ogihara	Kunihiko Tamaki, Dermatology	Rainer Schmelzeisen Shiro Nozawa	Chieko Sugishita, Family Nursing	William L. Holzemer Reiko Ueda
	Coffee break (20min)							
15:50-16:20	Masashi Fukayama, Human Pathology	Kenneth Nilsson Yukihiko Kitamura	Kazuhiro Nakahara, Clinical Laboratory Medicine	Robert W. McCarley Toshio Ogihara	Kiyonori Harii, Plastic & Reconstructive Surgery	Rainer Schmelzeisen Shiro Nozawa	Sachiyo Murashima, Community Health Nursing	William L. Holzemer Reiko Ueda
16:20-16:50	Kohei Miyazono, Molecular Pathology	Kenneth Nilsson Yukihiko Kitamura	Yasuyoshi Ouchi, Geriatric Medicine/ Aging Research	Robert W. McCarley Toshio Ogihara	Tsuyoshi Takato, Oral & Maxillofacial Surgery	Rainer Schmelzeisen Shiro Nozawa	Susumu Wakai, International Community Health	Stephen McGarvey Yoshiki Aoki
16:50-17:20	Kouji Matsushima, Molecular Preventive Medicine	Nahum Sonenberg Kumao Toyoshima			Kozo Nakamura, Orthopaedic Surgery	Jae-Gahb Park Akira Kakita	Katsushi Tokunaga, Human Genetics	Stephen McGarvey Yoshiki Aoki
Feb. 18								
9:30-10:00	Akio Nomoto, Microbiology	Nahum Sonenberg Kumao Toyoshima	Teruhiko Toyo-oka, Organ Pathophysiology & Internal Medicine	Daniel K. Podolsky Takao Saruta	Makoto Araie, Ophthalmology	Rainer Schmelzeisen Shiro Nozawa	Hiroshi Ushijima, Developmental Medical Sciences	Stephen McGarvey Yoshiki Aoki
10:00-10:30	Tadatsugu Taniguchi, Immunology	Nahum Sonenberg Kumao Toyoshima	Takashi Igarashi, Pediatrics/Develop- mental Pediatrics	Robert W. McCarley Toshio Ogihara	Kimitaka Kaga, Otorhinolaryngology, Head and Neck Surgery	Rainer Schmelzeisen Shiro Nozawa	Ryutaru Ohtsuka, Human Ecology	Stephen McGarvey Yoshiki Aoki
10:30-11:00	Takaaki Kirino, Neurosurgery	Jean Pierre Julien Tadaharu Tsumoto			Fumio Eto, Rehabilitation Medicine	Jae-Gahb Park Akira Kakita	Kiyoshi Kita, Biomedical Chemistry	Stephen McGarvey Yoshiki Aoki
	Coffee break (20min)							
11:20-11:50	Joji Ando, System Physiology	Kenneth Nilsson Yukihiko Kitamura			Kazuo Hanaoka, Anesthesiology	Tadao Kakizoe Akira Kakita		
11:50-12:20	Shoogo Ueno, Biomedicine & Biomagnetics	Kenneth Nilsson Yukihiko Kitamura			Naoki Yahagi, Emergency & Critical Care Medicine	Tadao Kakizoe Akira Kakita		
12:20-12:50	Kou Imachi, Biosystem Construction & Control	Kenneth Nilsson Yukihiko Kitamura						
	Lunch (70min)							
14:00-14:30	Yasuo Ihara, Neuropathology	Jean Pierre Julien Tadaharu Tsumoto						
14:30-15:00	Morihiro Sugishita, Cognitive Neuroscience	Jean Pierre Julien Tadaharu Tsumoto						
15:00-15:30	Norio Suzuki, Radiation Oncology	Nahum Sonenberg Kumao Toyoshima						
	Coffee break (20min)							
15:50-16:20	Ken-ichi Yoshida, Forensic Medicine	Kenneth Nilsson Yukihiko Kitamura						
16:20-16:50	Kunio Shinohara, Radiation Research Institute	Nahum Sonenberg Kumao Toyoshima						
18:00-20:00	Reception at Seiyoken, 15th floor of University Hospital							

Report of the External Review

Executive Summary

Executive Summary

March 2003



Prof. Dr. Erwin Neher

Chair

The External Review Committee

The University of Tokyo Graduate School and Faculty of Medicine is among the leading institutions of biomedical research and education in Japan. In anticipation of pending structural reforms the senior faculty members have decided to perform a review of its research activities. For this purpose 21 experts from top biomedical institutions throughout the world and Japan have been invited for a two-day evaluation session. The conclusions and recommendations of this committee are being presented here. The summary of results is subdivided into four groups, reflecting the review process, which was conducted by the four subgroups of the panel

Group 1 comprises 23 departments dedicated to the basic biomedical sciences, and research oriented clinical departments. The panel noted that the classical disciplines of medicine have well been reorganized during recent years around the methodology and concepts of modern biomedical research. It was concluded that most departments are engaged in very original research, in which they are internationally highly visible, some of them leading their respective fields. Although the research work reviewed was mainly basic in nature outstanding clinical implications were observed, which are expected to redirect clinical practice in the future. The panel also identified a minority of research efforts for which reorientation and focusing was recommended.

Group 2 consists of 13 departments in clinical medicine. These departments are quite heterogeneous with respect to size and the subdivision of work between clinical educational and research duties. Research efforts include work on pathogenesis, pathophysiology, diagnosis, therapy and prognosis of diseases in the respective areas. The panel was impressed by the high academic motivation of the staff and by numerous important publications in internationally highly reputed journals. Furthermore, the panel was delighted to note fruitful collaborations with basic science departments within the University of Tokyo, but also with other facilities in

Japan and with prestigious academic institutions abroad. Note was taken of abundant grant money from outside sources, reflecting superb academic achievements. Regarding the overall organization of the clinical departments it was recognized that a better balance would be needed between the clinical and research staff with careful consideration of workloads regarding patient care and educational tasks. Such reorganisation should aim for adequate time for research activities in all areas. On the other hand research activities in some departments were found to cover too wide a range of topics. In such instances focusing and reorganisation is indicated.

Group 3 consists of 17 clinical departments centered around such fields as Surgery and Reproductive, Developmental and Aging Sciences. The panel was impressed by the fact that each department has succeeded over the past decade to successfully engage in basic as well as clinical research in spite of a 'terribly busy clinical practice' at the University Hospital. Research activities of the vast majority of departments were judged as excellent with respect to originality, productivity, scientific impact and clinical impact. In a few cases the panel pointed out that reorientation towards more specific research topics with strong clinical implications might be indicated for clinical research units, in which not only research but also clinical practice is conducted on a daily basis.

Group 4 comprises 15 departments in the fields of Social Medicine, Health Science and Nursing, and International Health. The panel concluded that, on the whole, the Graduate School and Faculty of Medicine at the University of Tokyo assumes a leading role in research in these fields in Japan. Some departments are regarded as world leaders in their respective disciplines. It was pointed out that the University of Tokyo has pioneered in Japan in establishing Biostatistics and Biomedical Ethics as newly required research fields in Health Research, and that professors of Nursing have taken a national lead in many aspects of their discipline. However, it was also recognized that the methods of the present review process may not be adequate to fully appreciate the quality of some of the departments in Health Sciences and Nursing. The panel noted that the International Health departments cover a wide range of medical and epidemiological topics of relevance both to the developed and developing world and concluded that the achievements apparent today clearly identify the University of Tokyo as a promising center of excellence in research on International Health. Closer inter-disciplinary and trans-disciplinary efforts will allow to further develop this role.

In summary it can be stated that the University of Tokyo Graduate School of Medicine combines world-class research in the most important biomedical research fields with excellent medical practice. It managed to make the transition in most disciplines from a solid-base traditional medical practice to research-oriented biomedicine, taking advantage of recent progress in molecular medicine and advanced biomedical engineering. The University of Tokyo Graduate School of Medicine is committed to complete this

process and is in a good position to do so, given the fact that it harbors world-class experts in many of the relevant disciplines.

The panel felt compelled to emphasize that the strength of the Medical School lies in an ideal balance between basic, knowledge-oriented research and applied or disease-oriented research - a balance, which emphasizes the importance of the former for the latter. Numerous examples were presented in which progress in basic research unexpectedly opened new insights into longstanding clinical problems, such as the discovery of genes responsible for malignant hyperthermia or for a hereditary neuropathy. It is in the very nature of knowledge-generating research that problem-solving insights happen unexpectedly and that they occur the more often the more knowledge-oriented research is allowed to follow its own path. The panel recommends that the University of Tokyo Graduate School of Medicine should continue to support its world-class biomedical research and this way build on its foundations for excellence in teaching and health care.

Addendum

The Process and Remit of the Review

Background: In view of pending structural reforms of the Japanese health care and university system and considering dramatic advances in knowledge in the biomedical sciences the Graduate school of Medicine of the University of Tokyo decided to conduct a review of its research efforts. The purpose of this exercise was supposed to be twofold: First, to provide guidance for the faculty in pending decisions on the further development of the School and second to document the international standing of the faculty within the rapidly changing international research scene. The review was intended to concentrate on research performance, with teaching and infrastructure issues covered only to the extent, which was considered necessary for optimal research conditions.

The Planning Committee: The review was prepared by a Planning Committee consisting of 6 senior faculty members and chaired by Prof. H. Okayama. The planning committee interacted with both the faculty and the review panel members by preparing the written materials (see below), formulating guidelines on the procedures of the review process, and to guarantee an efficient review process within the time available. Specifically, two panel members were assigned to each of the departments to be reviewed.

Materials and Documentation: Prior to the site visit panel members received two pieces of documentation besides general information regarding the University of Tokyo Graduate School of Medicine. One is a volume covering all of the departments with concise texts regarding their major research achievements, ongoing research, as well as future plans. In addition it included a reference list of up to 50 select scientific

publications and a listing of personnel as well as current grant support. The other is a collection of the ten most important publications and evaluation sheets on those departments, which had been assigned to a given panel member.

A schedule of the presentation and other events was mailed prior to the meeting. On-site panel members received information material on the University as a whole and on the Medical School. This included

- The March 2002 Edition of 'Tansei', The University of Tokyo Magazine
- the 2003 prospectus of the Faculty of Medicine/Graduate School of Medicine
- a site map

The review process: On the evening prior to the review, panel members met with the Dean of the Medical School and the Planning Committee for a decision of the procedures and aims of the review. One of the panel members, E. Neher, was designated as chairman of the panel. Furthermore, four additional members (Profs. M. Ito, T. Saruta, A. Kakita and Y. Aoki) were identified to cooperate with the chairman in the generation of the Review Summary Report by providing summary results of the four thematic subgroups (see page 19-37).

The main reviewing task was accomplished during the scientific presentations of the 68 departments, which were held in four parallel subgroups sessions on Monday, February 17th and Tuesday, February 18th, 2003. Each head of department was allowed 20 minutes of presentation time followed by up to 10 minutes of discussion.

The report: The evaluation sheets (two from independent panel members for each principal investigator) were made available to the chairman and to those responsible for the summary reports of the four subgroups. The reports were sent after the panel meeting to the chairman as the basis for this report. Drafts of the reports were circulated among the panel members and the final version was submitted to the Dean of the Medical School on 12th of March 2003.

Group Summaries

Group 1	
Reviewers	Ito, Masao (RIKEN, Japan) Julien, Jean Pierre (McGill University, Canada) Kitamura, Yukihiko (Osaka University, Japan) Neher, Erwin (Max-Planck-Institute, Germany) Nilsson, Kenneth (Uppsala University, Sweden) Sonenberg, Nahum (McGill University, Canada) Toyoshima, Kumao (RIKEN, Japan) Tsumoto, Tadaharu (Osaka University, Japan)
Summarized by	Ito, Masao
<p>General Comments and Suggestions:</p> <p>While reviewing the twenty-three departments of Group 1, we were deeply impressed by the high standards and the extensive coverage of the topics presented to us. Through this review, we realize that the classic disciplines of medicine such as anatomy, physiology, biochemistry, pharmacology and pathology have been well reorganized during the past ten years around the methodology and conceptualization of modern biomedical research at molecular, cellular, system and cognitive levels.</p> <p>We used a five-grade rating system for evaluation (A: excellent, B: very good, C: good, D: fair, E: poor) of each of the four aspects of research, namely, originality, productivity, scientific impact and general aspect. Two assigned members of the review committee rated each of the 23 departments of group 1. The highest grade, AA, was given to 13 departments for originality, 11 for productivity, 7 for scientific impact, and 9 for general aspect. Hence, about one-half of the reviewed departments were deemed excellent. When we counted all of the AA, AB and BB grades, 19 departments were evaluated as excellent or very good for originality, 19 for productivity, 17 for scientific impact and 20 for general aspect. We conclude that most departments have chosen highly original research topics and conducted productive research with high scientific impact. These departments published numerous original papers in English, many of which appeared in highly prestigious journals. The heads of the departments are well-established leaders and are frequently invited to international symposia or lectures. We applaud the remarkable achievements of the reviewed departments and their heads, and wish that the Faculty of Medicine, University of Tokyo continues to lead in biomedical research worldwide.</p> <p>The research works we reviewed are mostly basic in nature. However, when the clinical implication was rated optionally, 16 departments were given at least one A grade. Therefore, we observe an outstanding clinical implication in the research we reviewed, even though its strength varies from department to department.</p> <p>We, however, note that six of the 23 reviewed departments received a low grade for one or more aspects. Three of them receiving C grades may require improvement of their research performance. Two departments received D grades, one for the relatively low productivity represented by the publication output and the other for the lack of innovative approaches. Another department received E grades because its research outcome was disappointing. We recommend that these three departments reconsider their research plans and strategies.</p> <p>Specific Comments and Suggestions for Research Activities in Each Field within the Group:</p> <p>I. Cellular Signaling, Molecular Biology, Cell Biology and Anatomy, Physiological Chemistry & Metabolism, Integrative Physiology, Cellular & Molecular Physiology, Neurophysiology, Cellular & Molecular Pharmacology, and Molecular Neurobiology</p> <p>Modern medicine is firmly based on biomedical research that clarifies molecular, cellular and system mechanisms of a normal living body. The nine departments in field I constitute a major core of such research activities in the Faculty of Medicine, University of Tokyo. For the general aspect, four of them were rated with AA, another four with AB, and the remaining one with BB; hence, the nine departments of field I were all evaluated as either excellent or very good.</p> <p>Prof. Shimizu's group (Department of Cell Signaling) mainly focuses on an increasingly promising area, namely, lipid signaling. They cloned leukotriene A4 hydrolase, a key enzyme in the leukotriene biosynthesis, and successfully produced various types of gene-manipulated mouse deficient in the</p>	

leukotriene receptor, PAF receptor or cytosolic phospholipase A2, or mouse over-expressing the PAF receptor. Prof. Okayama's group (Department of Molecular Biology) targets the cell cycle control, differentiation control and anchorage-dependent growth, using the technology of the full-length cDNA cloning, which Prof. Okayama and Prof. Paul Berg reported in 1982 and revolutionized the field of gene cloning. This group continues to produce interesting results linking the cell cycle to oncogenesis. Prof. Hirokawa (Department of Cell Biology and Anatomy) heads a large dynamic group whose productivity has been truly outstanding. They have successfully analyzed motor proteins functioning in axonal and dendritic transport and identified most members of the kinesin gene family and clarified how they function as molecular motors. They have made several epoch-making discoveries; e.g., a deficiency in KIF1 B β causes type 2A Charcot-Marie-Tooth neuropathy and KIF3 knockout leads to the loss of the right-left asymmetry in normal body formation.

Using gene manipulation, Prof. Kurihara's group (Department of Physiological Chemistry & Metabolism) discovered that endothelin (ET-1) is required for the formation of craniofacial and cardiac neural crest structures including brachial arches and great vessels, and that adrenomedullin (AM) is indispensable for vascular morphogenesis during the development and regulation of blood pressure by NO production. These provide the bases for their further work on the development of neural crest and vascular systems. Prof. Miyashita's group (Department of Integrative Physiology) takes the challenge of clarifying neural mechanisms of learning and memory, ingeniously combining molecular approaches with synaptic plasticity, microelectrode recording from monkey brains and fMRI imaging of human brains. They previously discovered specific memory neurons in the monkey ventral infratemporal cortex and more recently have shown that these neurons operate using the brain-derived neurotrophic factor (BDNF). They have recently demonstrated the top-down signals from the prefrontal cortex for retrieving memory from the infratemporal cortex. Prof. Mori's group (Department of Cellular & Molecular Physiology) developed genetic and imaging techniques for investigating specific neuronal connections that form the odor maps in the olfactory system, including the olfactory bulb, pyriform cortex and olfactory tubercle. Their work is now extended to clarify how specific connections are generated through neurogenesis by axonal recognition of target neurons.

Prof. Takahashi's group (Department of Neurophysiology) conducts excellent cell-physiological analyses of synaptic transmission, using the unique preparation of the Calyx of Held, a synapse in the auditory pathway in which both presynaptic and postsynaptic compartments can be patch-clamped. This laboratory masters such a technically demanding task hardly like any other laboratories, worldwide. Works by Prof. Iino's group (Department of Cellular & Molecular Pharmacology) excels in its quantitative description of cellular processes related to IP₃-induced calcium signals in neurons. They characterized different subtypes of IP₃ receptor playing different roles in various cell types. They have recently developed genetically encoded sensors for IP₃. Prof. Mishina's group (Department of Molecular Neurobiology) is world-renowned for their contribution to the cloning of ion channel proteins, particularly in identifying diverse NMDA receptor subtypes and their functional roles. His group identified the delta 2 type of glutamate receptor, specifically located in cerebellar Purkinje cells. His group now attempts to combine mouse and zebrafish genomics to obtain insights into brain development and function.

II. Pathology, Molecular Pathology, Neuropathology, Forensic Medicine, Molecular Preventive Medicine, Microbiology, Immunology, and Neurosurgery

The eight departments constituting field II are dedicated to disease-oriented research that identifies the causes of various diseases such as cancer, virus infections, heart or brain ischemia and Alzheimer's disease, aiming at developing innovative medical treatments. For the general aspect, five of them were evaluated as AA, another one AB, and the remaining two BB; hence, all of the eight departments of field II are evaluated as excellent or very good.

Prof. Fukayama (Department of Human Pathology) conducts high-quality "niche" research on Epstein-Barr virus-associated neoplasms and also on lung carcinoma. This area, however, needs to introduce more new methodologies of molecular pathology. Their decision to merge with the Division of Surgical Pathology of the University Hospital is reasonable and would allow more translational research. Prof. Miyazono (Department of Molecular Pathology) developed his earlier world class work with Prof. C. -H. Heldin to a new line of work on carcinogenic effects of the transforming growth factor- β (TGF- β). He is in a position to reformulate traditional pathology to molecular pathology, and appears to need more resources and support. Prof. Ihara's group (Department of Neuropathology) focuses on molecular mechanisms underlying Alzheimer's disease pathogenesis, and has made important contributions to the field of amyloidogenesis with improvement of a method for quantifying amyloid β in human brains. Very recently,

they have discovered the ϵ cleavage, distinct from the β - and γ -cleavage thus far established as the mechanism underlying amyloidogenesis in the brain. Prof. Yoshida's group (Forensic Medicine) works on reactive oxygen generation, lipid peroxidation, and injury and death of the myocardium or brain after ischemia reperfusion or intake of toxic substances, which are subjects closely relevant to forensic medicine. This group also aims to contribute to the legal aspects of forensic medicine, and to improve methods in forensic pathology. As an interface between the society and medicine, forensic medicine inevitably covers broad areas, but for this group, a more focused approach may enhance its research activity.

The works on the molecular pathogenesis of inflammatory and immune diseases of Prof. Matsushima's group (Department of Molecular Preventive Medicine) were deemed highly original, and if his presentation had been better organized, the rate would have been even higher. Prof. Nomoto (Department of Microbiology), known for his pioneering work on poliovirus, is now extending his group's research to clarifying the mechanisms underlying the shut-off host protein synthesis by poliovirus. His work provides a useful model for hepatoma development in hepatitis C virus (HCV) patients, which is expected to be applicable to other viral diseases as well. Prof. Taniguchi (Department of Immunology), renowned for his pioneering work on cytokines, impressed the reviewers by the remarkable breadth and depth, and groundbreaking significance of his group's research. It is hoped that the complex protein machinery in the immune system that his group uncovered will be further analyzed using novel technologies (for instance, cryoelectron microscopy). Prof. Kirino's group (Department of Neurosurgery) has made important contributions to research on cerebral ischemia as well as on genetic analysis of tumors. They demonstrated that the proteasome activity plays a key role in neuronal death after brief cerebral ischemia and that mice deficient in NR2A NMDA receptors are less vulnerable to ischemic insult. A major breakthrough is the finding that endogenous neuronal progenitors can be induced in situ to replace hippocampal neurons damaged after ischemia.

III. System Physiology, Bioimaging & Biomagnetics, Biosystem Construction & Control, Cognitive Neuroscience, Radiation Oncology, and Radiation Research Institute

These six departments are grouped together because of their two common features, namely, they require large instruments and develop physical, rather than chemical, means for diagnosis and therapy. A general difficulty in establishing this research field III, in spite of its importance as an interface between biomedical research and clinical medicine, is reflected by the fact that the six departments received no A grade for the general aspect. Three of them, nevertheless, received BB, that is, "very good", but the remaining three received low scores reflecting problems in their research plans or strategies.

Prof. Ando's group (Department of System Physiology) studies the effects of shear forces on endothelial cells. The experimental device used to apply shear stress to cultured endothelial cells is valid, and it provides the basis for their attempt to identify a flow sensor, shear-induced changes in gene expression, and signal transduction in endothelial cells. The work, however, is still in a descriptive stage, and a more focused approach may benefit them. The transcranial magnetic stimulation (TMS) performed by Prof. Ueno's group (Department of Bioimaging and Biomagnetics) is in the front line of this field. Their finding that repetitive TMS facilitates regeneration or prevents damage to rat hippocampal neurons may have important clinical implications. The biological effects of strong static magnetic fields on mammalian cells are interesting, and studies of these effects should be expanded using advanced technologies of cell physiology, probably in collaboration with other departments. These basic studies may offer a basis for securing our health in environments where significant high-frequency electromagnetic waves emanate from an increasing number of commercial products such as mobile telephones. Prof. Imachi's group (Department of Biosystem Construction & Control) has inherited the long tradition of artificial heart engineering in the Faculty of Medicine, University of Tokyo, and extends it to develop an implantable total artificial heart (TAH) that has so far enabled an implanted animal to survive for 63 days. This group will benefit from collaborations with clinicians as well as cell biologists, particularly if, as is suggested in their future plans, they are going to start analyzing ES cells to generate whole organs. In view of the difficulty in heart transplantation, in particular in Japan, a rapid progress of the TAH project has a great social significance.

Prof. Sugishita's group (Department of Cognitive Neuroscience) primarily focuses on the use of MRI and magnetoencephalography (MEG) in studies of human cognitive functions. Mapping of brain regions involved in writing and face recognition is the main contribution of this group. Since Prof. Sugishita will retire very soon, reformulation of the aim of the Department including a new research plan is essential for developing the important field of cognitive neuroscience. Prof. Suzuki's group (Department of Radiation Oncology) group focuses on two research subjects, 1) radiation-induced signal transduction and apoptosis, and 2) function of DNA protein kinases in double-strand-break repair and cell death. Their studies,

however, appear to have diverged beyond the capacity of a relatively small number of researchers in this group. It was also pointed out that not only the rather conventional approaches presently adopted but also innovative methods should be introduced. Prof. Kunio Shinohara' group (Radiation Research Institute) is so small that the scope of its activity is limited. They developed a new technology of soft X-ray microscopy that may have some potential, but its usefulness has yet to be demonstrated.

Group 2	
Reviewers	McCarley, Robert William (Harvard Medical School, USA) Ogihara, Toshio (Osaka University, Japan) Podolsky, Daniel K. (Harvard Medical School, USA) Saruta, Takao (Keio University, Japan)
Summarized by	Saruta, Takao
<p>General Comments and Suggestions:</p> <p>Group 2 consists of thirteen clinical medicine departments. They have different historical backgrounds, and the clinical and educational duties allotted to them also vary widely. Hence, their sizes and activity scales are not uniform, and the number of the faculty members and the staffs differ considerably. Regardless of the number of collaborators and the size of department, productive scientific research work with high originality has been conducted in each department within the framework of given conditions.</p> <p>One of the important tasks of clinical departments is to conduct research on the pathogenesis, pathophysiology, diagnosis, treatment, and prognosis of the diseases in each specialized area. The research activities of the majority of the thirteen departments that underwent external review are being conducted with well-defined objects and are considered satisfactory. It is well appreciated that in some of the thirteen departments, a highly organized translational medicine-oriented approach is being taken to correlate the research and the clinical activities.</p> <p>The majority of the staff of the departments that underwent review are highly motivated to act as the leading figures in this country through their clinical and research activities. The reviewers were impressed by the high academic motivation of the staff reflected in the official compendium that introduces their research activities. It is also impressive that numerous important publications in highly reputed journals have been made. In many instances, basic and clinical researches in these thirteen departments were performed in collaboration with basic science departments within the University of Tokyo, with other facilities in Japan, and also with some prestigious academic institutions outside this country. Undoubtedly, such collaborative works have been most rewarding. It should also be noted that these thirteen departments have received reasonably abundant academic grant moneys likely reflecting their superb academic achievements.</p> <p>It is concluded that the research activities in the departments of group 2 are highly satisfactory in general and that they should be encouraged to keep up with their current excellent performances. In some of the departments, however, the research activities have covered an excessively wide range of topics with rather scanty organization. It is advised that the research activities in such departments should be concentrated on a more limited number of topics in the future.</p> <p>In each of the departments in group 2, the staffs are expected to share various amounts of patient care duties and education. It is felt that the number of the staffs in each department should better be rearranged with careful consideration to the work loads that do not pertain directly to research activities: a larger number of staff personnel should be secured for the departments with greater patient loads and educational tasks to allow an adequate time for research activities.</p> <p>One final comment should be added to conclude this summary. This has been the first attempt to provide a comprehensive external review of the research activities of the Graduate School of Medicine of the University of Tokyo. Each of the professors was asked to make a presentation to the reviewers introducing the research activities of his department. The form and the method of the presentation had not been predetermined but were left to each of the presenters, resulting in presentations which differed considerably in organization, length, and technical quality. It is possible that this situation exerted some influence on the final evaluations made by the reviewers.</p> <p>Specific Comments and Suggestions for Research Activities in Each Field within the Group:</p> <p>1. DEPARTMENT OF INFECTION CONTROL AND PREVENTION: This department has made important contributions in the prevention and control of hospital infections within the university hospital as well as in other hospitals throughout Japan. It has also played an important role as the center of diagnosis and treatment of HIV-infection in this country. The research activities of the department have been focused on the prevention of MRSA infection, anti-HIV agents, and on basic mechanisms of hepatotropic viral infections. In view of the significance of the clinical and scientific contributions being made by this department, it is recommended that the number of its faculties</p>	

be increased in the future.

2. DEPARTMENT OF RADIOLOGY:

The department of radiology has played a leading role in diagnostic radiology, radiation oncology, and nuclear medicine in this country through multiple clinical research projects. Applications of magnetic resonance imaging and positron emission tomography in the diagnosis and studies on the pathophysiology of various diseases have yielded contributions highly valued internationally. The department is expected to continue its current research and clinical activities, and is also anticipated to extend its efforts to some newer fields of radiology including interventional radiology.

3. DEPARTMENT OF NEUROPSYCHIATRY:

Since 1994, when the ward and the ambulatory sectors of neuropsychiatry made the historical reunion, the members of this department have been remarkably productive in their research activities. In particular, their achievements in the study of post-traumatic disorders (PTSD) have been watched with keen interest. Application of neuroimaging techniques to the study of human neuropsychiatric disorders is another important contribution made by them. Basic research works using animal models are also being pursued. It is hoped that the department keeps up with its highly productive clinical and academic activities.

4. DEPARTMENT OF NEUROLOGY:

It is only six months since the current professor and chairman of this department took his office. The department, however, is already making new important contributions in the study of molecular mechanisms of neurodegenerative disorders under the superb leadership of the new department chairman. It is anticipated that the department will continue to play a leading role in the researches in molecular genetics and gene therapy of neurodegenerative disorders.

5. DEPARTMENT OF CARDIOVASCULAR MEDICINE:

This department has been providing a comprehensive quality patient care in cardiovascular medicine. Many basic research works have also been conducted, including a series of internationally valued studies on the molecular biology of cardiac hypertrophy and cardiomyopathy. It is noteworthy that the members of this department are attempting intensively to integrate the research and clinical activities.

6. DEPARTMENT OF GASTROENTEROLOGY:

This department has been actively involved in the study of pathogenesis, treatment, and prevention of viral hepatitis and hepatocellular carcinoma that follows HCV infection, and it has undoubtedly played an internationally recognized leadership in these fields. Important basic researches on the relationship between Helicobacter pylori infection and gastric carcinoma have also been done. This department holds a well-organized system to undertake research works relevant to clinical gastroenterology. It is hoped that it extends its effort further to the study of gastrointestinal tract malignancies besides gastric cancer.

7. DEPARTMENT OF NEPHROLOGY AND ENDOCRINOLOGY:

The research works of this department have covered a surprisingly wide range of topics yielding many publications in the journals with high impact factors. However, it is the impression of the reviewer that the research activities of the department have been spread over an excessively wide range of topics. The department is advised to take a more organized approach in its research activities that enables strategic handling of the selected subject matters by the collaborative works of its members.

8. DEPARTMENT OF ALLERGY AND RHEUMATOLOGY:

The research activities of this department have been translational medicine-oriented, and have dealt with the pathogenesis of autoimmune disorders, basic immunology, and various clinical research works. The publications made in the journals of basic immunology with high impact factor ratings are impressive, although it is the opinion of the reviewer that more papers had better been submitted to the journals of internal medicine. The current research activity of the department, which is centered on the function of antigen-specific T lymphocytes, is anticipated to yield discoveries highly important in immunology and immunotherapy.

9. DEPARTMENT OF PSYCHOSOMATIC MEDICINE:

The members of this department have been actively involved in research on eating disorders and panic disorders. Unfortunately, however, it is the opinion of the reviewer that their research efforts have not always been most productive. Psychosomatic medicine should play an important role in our modern society. It is encouraged that the members of this department continue with their efforts to make publications in the journals with higher impact factor ratings and international reputations.

10. DEPARTMENT OF CLINICAL LABORATORY MEDICINE:

This department holds only two faculty members, both of whom serve concurrently as staff of the Clinical Laboratory Center. This situation should be somewhat limiting to the research activities of this department. The research works of this department, however, have covered a surprisingly wide range of topics. The reviewer is of the opinion that the research activities of this department should be concentrated on a more limited number of topics. An increase of the personnel of this department should also be seriously considered.

11. DEPARTMENT OF GERIATRIC MEDICINE/DEPARTMENT OF AGING RESEARCH:

This department was established in 1962 as the first geriatric medicine department of this country, and has been held as an ideal model of the provider of medical care for the aged and for research in geriatric medicine. The research works of the department have dealt with a wide range of topics including bone metabolism, atherosclerosis and respiratory diseases. The opinion was expressed that the research activities of this department had better been targeted on more selected subject matters relevant to geriatric patient care.

12. DEPARTMENT OF ORGAN PATHOLOGY, INTERNAL MEDICINE AND HEALTH SERVICE CENTER:

The members of this department are assigned to the health care of the faculty, the students and the employees of the University of Tokyo. Therefore, the time they can spend for research should not be too abundant. The research activities of this department have been focused on the molecular biology of cardiac dysfunction. The department is expected to be involved in researches that have relevance to mass health care.

13. DEPARTMENT OF PEDIATRICS:

Pediatric medicine is expected to cover a wide range of health issues of children, and this department has done a remarkable job to bring this expectation to effect. Many important papers, both basic and clinical, have been published in journals of high impact factor ratings. The department is expected to continue with its currently superb research activities. It is also hoped that it extends its activity to the study of mental health disorders of the children.

Group 3	
Reviewers	Kakita, Akira (Kitasato University, Japan) Kakizoe, Tadao(National Cancer Center, Japan) Nozawa, Shiro (Keio University, Japan) Park, Jae-Gahb (National Cancer Center, Korea) Shmelzeisen, Rainer (Albert-Ludwigs-University, Germany)
Summarized by	Kakita, Akira
<p>General Comments and Suggestions;</p> <p>The group 3 consisted of 17 departments in various clinical fields such as Surgical Sciences and part of Reproductive Developmental and Aging Sciences of the University of Tokyo Graduate School of Medicine. Five members of the review committee took part in the evaluation of these departments. Two of the 5 members reviewed one department and each referee independently reported his reviewing result of the research activities of each department.</p> <p>Through the entire review process, we were aware of and impressed by the fact that, under the circumstances of terribly busy clinical practice in the University Hospital, each department had spared no pains to performing basic as well as clinical research during the past decade, despite many restrictions on the time and money, the number of working staffs and research associates, and the installation for research activities as well, in each department. In general, there were no remarkable differences among the reviewed departments, although some departments had a long history as well as a bunch of research projects accumulated since their foundation, whereas others had been instituted only recently.</p> <p>Two assigned referees independently gave an assessment of the department after extensively reviewing a self-documentation on the outline of past accomplishment, present research activities and future prospect, as well as a hearing done for 2 days on research activities of each department. The referees used a five-graded scale for their evaluation (<i>i.e.</i>, A: excellent, B: very good, C: good, D: fair, and E: poor) for each of the following 5 categories: the originality, productivity, scientific impact, clinical impact, and general rating. The highest mark AA was given to 9 departments for the originality, to 7 departments each for the productivity, scientific impact and clinical impact, and to 10 departments for the general rating. All but one department obtained marks of CC and superior for the 5 categories; only one department obtained the mark CD for the category of clinical impact.</p> <p>To inclusively assess departmentis research activity, scores from 5 to 1 were given to the grades from A to E, respectively, and the sum of 2 refereeis scores in each category (<i>e.g.</i>, AA=10, AB=9, BB=8, etc.) was classified into three ranks defined as excellent (the score 8 or larger), ordinary (the score 6 or larger), and poor (the score less than 6). Thirteen departments were ranked as excellent and 4 departments as ordinary for the category of originality. For the productivity, 15 departments were ranked as excellent and 2 as ordinary. For the scientific impact, 13 were evaluated as excellent and 4 as ordinary. For the clinical impact, 13 departments were ranked as excellent and 3 as ordinary, whereas 1 department was ranked as poor. It may be noted that 15 of the 17 reviewed departments (88%) were ranked as excellent in the category of productivity, indicating that the prospects for further expansion of research activities in these departments are promising.</p> <p>Finally, looking at the assessment result for the category of general rating, 12 departments were ranked as excellent accounting for 70% of the 17 departments reviewed. Thus, it may be concluded that most department heads are well supervising their staff and fellow doctors including research associates, and are successfully directing their departments. For some of the remaining 5 departments ranked as ordinary, however, it would take a bit more time to make any progress in their current research activities. In addition, there was a suggestion from the reviewers to some of these departments that efforts might better be directed toward the institution and execution of well-designed research projects on more specific subjects with strong clinical impact, because these departments are regarded as clinical research units, in which not only basic research but also clinical research and practice are conducted daily, and also because newly established departments very often have several limitations to their research environment.</p>	

Specific comments and suggestions to each subspecialty group of Departments in group 3:

1. Surgery

Cardiothoracic Surgery; Gastrointestinal Surgery/Surgical Metabolism and Nutrition and Endocrine Surgery; Hepato-Biliary-Pancreatic Surgery/Artificial Organs and Transplantation; Urology, and Surgical Oncology

For the category of general rating, all 5 departments in this group were ranked as excellent with the average score of 8.8 (ranging from 7 to 10) in accordance with the scoring system defined above. It thus appears that their research activities are to be favorably evaluated as excellent.

Department of Cardiothoracic Surgery (Takamotois group) has made remarkable contributions to the field of thoracic and cardiovascular surgery especially in aortic valvular and coronary artery bypass surgeries, and thoracic surgery as well. In general, very good clinical setting-oriented research projects have been conducted to date. It is expected that many patients in the clinic would benefit from their continuous research activities.

Dept. of Gastrointestinal Surgery (Prof. Professor Kaminishiis group) has focused its research interests on the pathophysiology and carcinogenesis of the gastrointestinal tracts system. The development of a model for creating chronic gastric ulcer, which was published in *Gastroenterology*, may be assessed as an exceedingly unique and creative work. Also, a series of experiments related to *Helicobacter pylori* infection and its eradication are very interesting. Research efforts in the future may better be exerted to vigorously continue the investigation on the carcinogenesis of gastric cancer.

Dept. of Hepato-Biliary-Pancreatic Surgery/Artificial Organs and Transplantation (Prof. Makuuchiis group) has introduced and standardized the systematic subsegmentectomy of the liver, which is emerging as the most significant idea in recent hepatic surgery, especially in cirrhotic livers. Prof. Makuuchi also proposed the concept of preoperative portal vein embolization in the event of extensive hepatic resection in patients with hilar bile duct cancer to minimize the postoperative hepatic dysfunction. Most of all, he and co-workers are the first in the world to have performed adult-to-adult living related liver transplantation (LRLT), and have greatly contributed to improving the surgical techniques as well as the post-transplant outcomes. Thus, their accomplishment may be favorably evaluated as excellent and their endeavor to develop the hepatic surgery be respected, although they appear to attach too much importance to clinical issues.

Dept. of Urology (Prof. Kitamurais group) has made good contributions to the understanding of multifocal carcinogenesis in the urinary bladder and also to the development of dendrite cell immunotherapy for patients with metastatic cancer. Moreover, a series of studies on urinary polyoma virus JC virus for the past decade have a great impact on the development of the diagnostic as well as therapeutic modalities. These excellent findings, which had originated from well designed clinical as well as experimental studies, were recognized by several good international journals, and the results of this research is expected to contribute to the advancement of the clinical urologic fields. There was a suggestion that these studies on the carcinogenesis of urinary system should be continued and the knowledge obtained from this research should be further directed toward clinical applications in the future.

Dept. of Surgical Oncology (Prof. Nagawaís group) has made a contribution to furthering not only basic sciences such as immunology, molecular biology, and genomics, but also clinical oncology. It provides comprehensive evaluation, diagnosis, treatment and management for adult patients with both general and oncologic surgical problems, in the ambulatory as well as inpatient settings. Among many excellent studies of this department, the study that lateral nodes dissection is not necessary for patients with lower rectal cancer undergoing preoperative radiotherapy is considered really important and very useful for treating patients with advanced rectal cancer. These outstanding works would provide clinicians and practitioners with valuable and novel ideas for managing patients. Prof. Nagawaís ardor for scientific knowledge and quality care of the patients should continue to be held.

2. Sensory and Motor System Medicine

Dermatology; Plastic and Reconstructive Surgery; Oral and Maxillofacial Surgery; Orthopedic Surgery; Ophthalmology; Otorhinolaryngology, Head, and Neck Surgery; Rehabilitation Medicine

For the category of general rating, six of the 7 departments in this group gained the full mark, AA, or were ranked as excellent (the average score of 10 in accordance with the scoring system). The remaining 1 Department was assessed as ordinary, or as good with the mark, CC.

Department of Dermatology (Prof. Tamakiis group) appears as a well-structured, young

department showing good cooperation with other departments in the University, and also appears very productive as indicated by its publications with a very high impact factor. This can be considered as a successful transition from research to clinic. This group has shown a strong focus in the research front with increasing applications of research results for clinical diagnosis. It has incorporated both cytokines research and immunological research into the clinical realm. Research into the basic mechanisms of immunology is applicable not only to Dermatology but to Cell Biology in general. Results of the research work on metastasis of melanomas are similarly applicable to the mechanisms of metastasis in other malignancies. Constructive criticism would be aimed at the application of the results of research works to the treatment of diseases in addition to the expanding molecular, enzymatic, and immunological diagnosis of dermatological disorders. It is believed, however, that the direction of its perceptive studies would eventually incorporate these goals towards actual clinical treatment of diseases.

Prof. Harii and co-workers (Dept. of Plastic and Reconstructive Surgery) have shown exceptional ability to lead the vanguard in the still emerging field of reconstructive surgery. They have introduced new surgical procedures and also have incorporated new techniques into the reconstruction of muscle and bony structures for cancer patients. In addition, they have pursued new research leads into the molecular basis of disease as well as the possibility of stem cell differentiation into tissues for skin and hair replacement. Their outstanding research has had extremely strong impact on Plastic Surgery, and their excellent articles that appeared in high-ranked journals have been appreciated worldwide. This clinical as well as basic research should be continued in cooperation with other departments. In particular, the possible use of epidermal and mesenchymal stem cells for replacement of various surface structures holds increasing promise for the future. Optimization of their transformation and shaping/molding are topics for continuing research. Moreover, their focus on the genetic basis of congenital anomalies related to plastic/reconstructive surgery is commendatory. These supportive suggestions reconfirm the general positive trend of research carried out by this Department.

Department of Oral and Maxillofacial Surgery (Prof. Takatoís group) has taken multi-pronged or multidisciplinary approaches to both clinical and basic research studies that are very commendable. On the clinical front, in expanding the horizons of maxillofacial surgery, multidisciplinary approaches hold promise for broadening treatment options for patients with deformities or tumors of the oral region. On the research front, the collaborations with various academic as well as corporate groups are broad and varied, and continue to shape the future for reconstructive oral and maxillofacial surgery. The broad diversification of research is to be lauded. This department has exhibited the delicate balance in stewardship necessary to finesse the strengths obtained from both corporate and academic collaborations. This department has shown a similar approach to translational research; the diversification of oral reconstructive surgery to regenerative technology and development are exemplary and show strong promise for the future.

Dept. of Orthopedic Surgery (Prof. Nakamuraís group) has done outstanding research in the field of orthopedics, especially of bone destruction, osteoclastogenesis in such areas as rheumatoid arthritis, senile osteoporosis, and spinal cord or neuronal injuries. The departmentís research targets are very clear, and excellent results of those research works were published in several prestigious international journals including *Nature*. These results have been quite useful in the clinical orthopedic settings. This work is believed to serve as a firm basis for deepening our understanding about orthopedic research. Studies on the pathogenesis of osteoclastogenesis and therapeutic tools for damaged spinal cord should be better continued in the future.

Dept. of Ophthalmology (Prof. Araieís group) has shown a strong focus on both the clinical and basic research forefronts of glaucoma pathophysiology and treatment. In clinical research, the pharmacokinetic evaluation and determination of pharmacological characteristics of various treatment modalities for glaucoma are substantiated. In basic research, the investigations into the underlying molecular biology and pathophysiology of glaucoma are similarly tangible foundations for future treatments. It may appear that this department attaches too much importance to the evaluation of various treatment modalities for glaucoma; an expansion of these developments and applications to other ophthalmologic disorders is strongly suggested. Similarly, the research focus of the department is strongly directed toward glaucoma and related fields; collaborations with other fields of basic research would be a welcome addition to its research portfolio. In this respect, the forays into corneal transplantation using regenerative medicine and amniotic cell replacement are innovative and very promising.

Dept. of Otorhinolaryngology, Head and Neck Surgery (Prof. Kagaís group) has shown a strong propensity for developing the products of research into innovative therapeutic modalities. On the clinical forefront, this department continues to expand the pathophysiological understanding of the various sensory organs while incorporating new treatment strategies towards malignancies. On the research forefront, the

group continues to focus on the basic underlying mechanisms of disease that may lead to future clinical applications. Its work continues to be both broad in scope and deep. Its applications of research harvests to clinical treatments, especially in new substitutive modalities for the sensory organs, are intuitive and original. Prof. Kaga seems to have taken strong leadership in publishing various articles as lead author during his tenure; it is laudatory that he demonstrates the initiative in publishing to junior members of the department.

Recognized as a new-borne department in clinical medicine field, the Department of Rehabilitation Medicine (Prof. Eto's group) has been focusing its studies on the field of geriatric and stroke rehabilitation. This group is especially interested in the functional and motor behavioral assessment of geriatric and brain-disordered populations, and has published several good relevant articles. In addition to committing themselves to clinical studies, Prof. Kaga and co-workers have recently broadened their research spectrum to cover animal experiments, tissue and biomechanical studies. Because Prof. Eto has a strong standing in the field of rehabilitation for geriatric people, research should better be continued in this field. Moreover, it may be recommended that this department should institute a couple of more specific research theme in this particular field of clinical medicine.

3. Vital Care Medicine

Anesthesiology; Emergency and Critical Care Medicine

The reviewers gave the mark BC each to these departments for the category of general rating, which is favorably evaluated as good or ranked as ordinary (the average score of 7 each) according to the scoring system.

Department of Anesthesiology (Prof. Hanaoka's group) has concentrated its energies mainly on the topics and themes that were closely connected to the anesthesiology, namely, respiration and circulation, pain management, muscle relaxation, development of new devices and techniques for anesthesia, mechanisms of anesthesia, shock, and perioperative quality of life control. Above all, the establishment of the guideline for postoperative pain management using local anesthetics combined with narcotics via epidural catheter to the epidural space may be noted as a remarkable accomplishment of this department. However, because of the multidisciplinary nature of research activities that this department is involved in, the objectives of basic as well as clinical research tend to be obscure and ambiguous. Therefore, it may be recommended that this department should institute much clearer objectives in the research field.

Dept. of Emergency and Critical Care Medicine (Prof. Yahagi's group) has only a small working staff serving as clinicians and surgeons at both the Emergency Center and the Critical Care Center. In spite of this awfully terrible condition, they not only have seen more than 17000 patients per year at the Emergency Ctr., but also have been engaged in many programs in a wide range of subjects related to basic researches as well as practical problems. Particularly, their works on the structural parts involved in activation and inactivation of Na channel that appeared in *Nature* (1989), and the clinical use of electrolyzed water (*Artificial Organs*, 2000) are considered very commendable. Their curiosity to as well as enthusiasm for research should not be discouraged from now on, and it is further suggested that they may better direct their research interest toward more basic/scientific subjects.

4. Obstetrics and Gynecology

Obstetrics and Gynecology; Gynecologic Surgery

Both of these 2 departments gained the mark AA, or a full score of 10, for the category of general rating. Thus, it appears that their research activities should be assessed and ranked as excellent.

In the Department of Obstetrics and Gynecology, Prof. Taketani has shown strong leadership in supporting both diversification and specialization in his department. His research and clinical applications for treatment of endometriosis are particularly noteworthy as well as his clinical prowess into the various assisted reproductive technologies. To be noted is the fact that, in basic research field, this department has been at the forefront of endocrinology and has expanded the knowledge of the underlying mechanisms of folliculogenesis and gametogenesis. Clinically, this department has recently shown strength in the field of fetomaternal medicine; this is believed to be a strong focus for the department in the future. In addition, it is expected that the fruits of these basic research works in endocrinology would find their way into clinical practice and technologies in the future.

Prof. Tsutsumi (Dept. of Gynecologic Surgery) has shown very active administration in both the clinical and basic research forefronts. This department has continued to lead the field in the application of

endoscopic surgery for gynecologic disorders. Especially, research works of this department on the determination and surgical indications for lymph node spread in gynecologic malignancies are noteworthy. In basic research, several works in molecular endocrinology and reproductive biology are very unique and intuitive. Any critical suggestions may not be necessary for this department. The work on environmental estrogens and reproductive biology are perspective and influential; similar collaborations of Prof. Tsutsumi's expertise in reproduction with experts in other fields may be recommended for the future.

5. Pediatric Sciences

Pediatric Surgery/Pediatric Oncology

Dept. of Pediatric Surgery (Prof. Hashizume's group) has concentrated its research interests on subjects in the following three areas, namely transplantation, developmental biology of congenital anomalies and fetal surgery, and immunology of intestine. The idea of tracheal occlusion was very interesting, although the clinical relevance was a little bit obscure. It may be recommended that the department should concentrate its resources on experiments more related to clinical activities. In addition, considering the very small departmental staff, it may be suggested to select and institute a couple of much clearer research objectives; experiments on beta-catenin, for example, seem to be too much.

Group 4	
Reviewers	Aoki, Yoshiki (Nagasaki University, Japan) Holzemer, William L. (University of California, San Francisco, USA) McGarvey, Stephen (Brown University, USA) Ueda, Reiko (Okinawa Prefectural Collage of Nursing, Japan)
Summarized by	Aoki, Yoshiki
<p>General Comments and Suggestions:</p> <p>Group 4 includes three research areas encompassing fifteen different departments. The three research areas are: 1) Social Medicine with two departments; 2) Health Sciences and Nursing with eight departments; and 3) International Health with five departments. Four reviewers were assigned to Group 4. Two reviewers evaluated the academic achievements of seven departments of Social Medicine and International Health, while the other pair evaluated eight departments within Health Sciences and Nursing. Evaluation followed the methods used by Groups of 1, 2 and 3. One reviewer assigned to Group 4 performed evaluations based solely on documents prepared specifically for this external review by the University of Tokyo.</p> <p>Inter-reviewer rating variation for the evaluation was relatively small among the group scores for all departments. Of the fifteen departments of Group 4, twelve received the highest or second highest ratings, AA, AB or BB. These results indicate that, on the whole, the Graduate School and Faculty of Medicine, Tokyo University, assumes a leading role in research on Social Medicine, Health Sciences and Nursing, and International Health in Japan, while some departments are regarded world leaders.</p> <p>A few departments within Health Sciences and Nursing received somewhat moderate or lower ratings. Although these departments are encouraged to strengthen the quality and quantity of their research, it may be that some, especially those belonging to Health Sciences or Nursing, have not been adequately evaluated by the methods of the present external review.</p> <p>Specific Comments and Suggestions for Research Activities in Each Field within the Group:</p> <p>Subgroup I; Department of Public Health, Department of Medical Informatics and Economics</p> <p>Subgroup I includes the Department of Public Health and the related Department of Medical Informatics and Economics. Both departments have published often in well-regarded, peer-reviewed journals. Accordingly, they are recognized as excellent or very good (AB, BB).</p> <p>Public Health must embrace a wide range of interdisciplinary research. The research areas targeted by Department of Public Health are all essential topics, and are of special significance to Japan. Prof. Kobayashi's group (Department of Public Health) presented research activities of high quality in varied, significant disciplines. This includes work on disabled elderly care system, tobacco control policy, the supply of physicians and their demographic and geographic distribution, cardiovascular disease risk factors, sarin poisoning, and other subjects. The long life expectancy and reduced birth rate has brought about a revolution of health policy in Japan. The academic achievements of Department of Public Health indicate that Prof. Kobayashi is making a significant contribution to an appropriate health policy for a changing Japan.</p> <p>The department of Medical Informatics and Economics currently has large service component as part of its overall mission in addition to its usual routine scholarly activities. Research interests within the Department of Medical Informatics and Economics are basic to technical innovation in medical science and health care in this country. Prof. Ohe's group (Department of Medical Informatics and Economics) has initiated research on the development of a hospital informatics system and standardization of medical information exchange. His group provides a useful information to medical staffs.</p> <p>Subgroup II: Four departments relevant to Health Sciences and four departments relevant to Nursing Sciences.</p> <p>Health Sciences: Department of Mental Health, Department of Social Gerontology, Department of Biomedical Ethics, Department of Biostatistics</p> <p>Beyond traditional Health Science two new research fields, Biomedical Ethics and Biostatistics. These have developed to reflect recent thinking about the social context of the conduct of research and newly required research methods in health research. Anticipating that biomedical ethics and biostatistics will be essential to the evolving Japanese system of medical education across the many school of medicine in the near</p>	

future, Tokyo University has assumed a leading role in these new areas of investigation. The decision to establish these departments was a visionary one. Many useful papers have appeared in peer-reviewed journals. However, scientific productivity of one department appears to be only moderate or low. Three departments are given the mark of excellent or very good (AB, AB, BB) and one is rated as score of good (CC).

Prof. Kurita (Department of Mental Health) significantly contributes to the diagnosis and treatment of pervasive developmental disorders. He is encouraged to continue promoting research reaching out to collaborators in nursing and other fields of healthcare.

Professor Kai's group focuses on health for the elderly, exploring fundamental human capacity, social support exchange, as well as the functional impact of home visiting and activities outside of the house. Gerontology today is a multidisciplinary field and, although worthwhile, the scope of current efforts here is too broad to be adequately addressed by the limited staffing now available. Professor Kai is encouraged to sharpen his focus within the areas of functional capacity and quality of life for the aged.

Prof. Akabayashi (Department of Biomedical Ethics) is investigating the development of social consensus, functions, and responsibilities of the ethical committee. He should play a vital role in developing a national code of biomedical ethics.

Prof. Ohashi's group (Department of Biostatistics) assumes a supportive role in clinical trials, admirably serving the biostatistical needs of various principal investigators. Beyond this worthwhile activity however, the department is challenged to become more engaged in their primary role, the development of new statistical methodology for biomedical research, clinical trials, and epidemiology. They are also encouraged to lend their supportive expertise to research areas other than clinical trials.

Nursing Sciences: 1) Department of Advanced Clinical Nursing/Nursing Administration, 2) Department of Adult Nursing/Terminal and Long-term Care Nursing, 3) Department of Family Nursing, 4) Department of Community Health Nursing.

The professors of nursing have taken the national lead in nursing administration, in adult, terminal, and long-term care nursing, and in family and community health nursing. There are some research areas which do not appear to fit into the mission of the respective department. Many papers, published only in Japanese, would have a greater impact if incorporated into the English language literature. Two departments are given a mark of excellent or very good (AB, BB), while two are rated as good (BC, CC).

Prof. Kanda's group (Department of Advanced Clinical Nursing/Nursing Administration) studies the national nursing workforce, with particular emphasis on staffing ratios as predictors of healthcare quality. They also address the measurement and improvement of quality of nursing care. This work has impacted national healthcare policy in hospital staffing ratios.

Prof. Kazuma's group (Department of Adult Nursing/Terminal and Long-term Care Nursing) has made an impressive use of the concentric circle model in research on muscle mass, exercise and fatigue. Her focus on nursing care in an outpatient setting is an exciting development that is strongly encouraged.

Prof. Sugishita's group (Department of Family Nursing) demonstrates national leadership in family nursing. They have published useful investigations in such diverse areas as acupuncture, elderly quality of life, and physiological nursing care actions. However, little attention has been given to the family per se. The department is encouraged to address both family and pediatric nursing.

Prof. Murashima's group (Department of Community Health Nursing) offers useful insights into the care delivery system, quality of care in the community health, and governmental policy. There appear to be many opportunities for collaboration with the Department of Social Gerontology in the area of health for the elderly and with Nursing Administration in the areas of seamless hospital-community discharge.

Subgroup III: Department of International Community Health, Department of Human Genetics, Department of Developmental Medical Sciences, Department of Human Ecology, Department of Biomedical Chemistry

Subgroup III includes five departments whose interests focus on the field of International Health. It covers a wide range of medical and epidemiological considerations, arising in both the developed and developing world. International Health must embrace the continuing and widening economic and political disparities that underlie poor health in developing nations. The research orientation of the chairman of each department is clear and appropriate and the research subjects targeted by each of the five departments are of high priority in the field of International Health.

Even though Japan lacks a long history in research of International Health, the chairs of these five departments, in their respective disciplines, have made considerable achievements in international health. All departments have numerous publications in recognized journals. Two departments are recognized with the highest scores, AA, and three are given a commendable AB.

Prof. Wakai's group (Department of International Community Health) has made significant progress in the socio-economic, behavioral and biological basis of health using epidemiological and public health analytic techniques. Prof. Wakai is an effective advocate for the theoretical and applied aspects of International Health.

Prof. Tokunaga's group (Department of Human Genetics) addresses some crucial areas of human genetics, including anthropogenetic studies of associated populations, their histories, and the genetic basis of disease. Their studies show that molecular genetics is a powerful tool with significant implications not only for International Health, but also more broadly for the future of biomedical science.

Prof. Ushijima's group (Department of Developmental Medical Sciences) has done extensive work on molecular epidemiology of diarrheal diseases and on social epidemiology in maternal child health. Such a program, linking basic science with maternal and child health, is an admirable innovation.

Prof. Ohtsuka's group (Department of Human Ecology) has made strides within a theoretical framework linking environment, socioeconomic factors and human populations. Their studies are characterized by holistic and multi-disciplinary approaches.

Prof. Kita's group (Department of Biomedical Chemistry) has demonstrated that basic research, including molecular biochemistry represents a powerful set of tools holding great potential for public health intervention. Their works on respiratory chains of eukaryote mitochondria and prokaryote cells may well lead to promising new treatments for parasitic diseases.

Achievements to date clearly identify the University of Tokyo as a promising center of excellence in the research of International Health. Nevertheless, close, inter-disciplinary and trans-disciplinary collaborative efforts have not yet matured. We strongly recommend that these departments interact with one other more effectively in order to develop their potential for world-class research in the field of International Health.

Research Activities

Graduate School of Medicine
The University of Tokyo

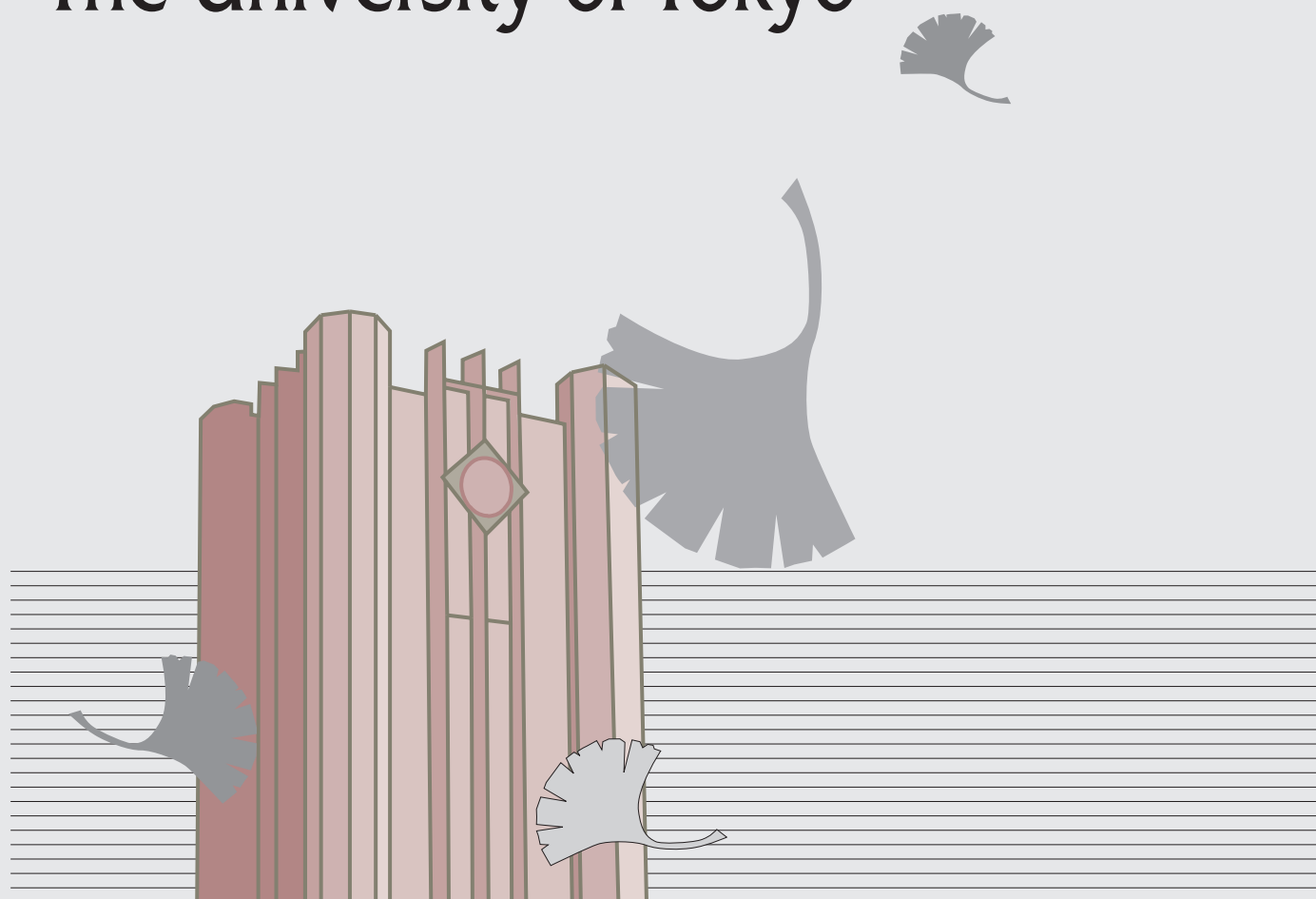

February, 2003

**Assembled and Edited by
the Planning Committee for External Review**

Hiroto Okayama
Nobutaka Hirokawa
Ryozo Nagai
Hirokazu Nagawa
Hiroshi Kurita
Susumu Wakai

Preface

The Graduate School and Faculty of Medicine of The University of Tokyo was established in 1886 as the Imperial University Medical College. In keeping with its tradition of leadership, it was recently modernized to increase the potential for further advances in research and education.

The Graduate School of Medicine has 66 departments, 4 closely associated facilities, and 6 endowed departments. The Graduate School grants doctoral degrees in basic medical sciences, clinical medicine, and public health, and a master's degree in medical science. A total of 200 graduate students are accepted each year. In addition, the faculty members are fully responsible for teaching undergraduate medical students. The departments are grouped into 11 programs: Molecular Cell Biology; Functional Biology; Pathology, Immunology, and Microbiology; Radiology and Biomedical Engineering; Neuroscience; Social Medicine; Internal Medicine; Reproductive, Developmental, and Aging Science; Surgical Science; Health Science and Nursing; and International Health. All are actively engaged in advanced research and education.

With the goal of improving our research activities, the senior faculty members recently decided to invite an external review. For this task, 21 internationally renowned scientists were selected to form the review committee.

This booklet outlines the past and current research status of each professor and each research group. Committee members may find this background information useful as they prepare to visit the campus and to hear the researchers' formal presentations. The visit and presentations will be held on February 17 and 18, 2003 at our Hongo campus. We greatly appreciate the committee members' willingness to share their time and expertise, and we welcome their candid and constructive evaluations of our research activities.

February 2003

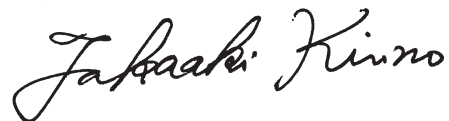
A handwritten signature in black ink, reading "Takaaki Kirino". The signature is written in a cursive, flowing style.

Takaaki Kirino, MD, PhD
Dean, Graduate School and
Faculty of Medicine
The University of Tokyo

Alphabetical List of External Reviewers

Aoki, Yoshiki (Nagasaki University, Japan)
Holzemer, William L. (University of California, San Francisco, USA)
Ito, Masao (RIKEN, Japan)
Julien, Jean Pierre (McGill University, Canada)
Kakita, Akira (Kitazato University, Japan)
Kakizoe, Tadao (National Cancer Center, Japan)
Kitamura, Yukihiko (Osaka University, Japan)
McCarley, Robert William (Harvard Medical School, USA)
McGarvey, Stephen (Brown University, USA)
Neher, Erwin (Max-Planck-Institute, Germany)
Nilsson, Kenneth (Uppsala University, Sweden)
Nozawa, Shiro (Keio University, Japan)
Ogihara, Toshio (Osaka University, Japan)
Park, Jae-Gahb (National Cancer Center, Korea)
Podolsky, Daniel K. (Harvard Medical School, USA)
Saruta, Takao (Keio University, Japan)
Schmelzeisen, Rainer (Albert-Ludwigs-University, Germany)
Sonenberg, Nahum (McGill University, Canada)
Toyoshima, Kumao (RIKEN, Japan)
Tsumoto, Tadaharu (Osaka University, Japan)
Ueda, Reiko (Okinawa Prefectural Collage of Nursing, Japan)

CONTENTS

Molecular Cell Biology

1. Cell Biology and Anatomy	
Department of Cell Biology and Anatomy	8
2. Biochemistry and Molecular Biology	
Department of Molecular Biology	14
Department of Cellular Signaling	20
Department of Physiological Chemistry and Metabolism	25

Functional Biology

1. Physiology	
Department of Integrative Physiology	30
Department of Cellular and Molecular Physiology	35
Department of Neurophysiology	40
2. Pharmacology	
Department of Cellular and Molecular Pharmacology	45
Department of Molecular Neurobiology	50

Pathology, Immunology and Microbiology

1. Pathology	
Department of Human Pathology	55
Department of Molecular Pathology	60
2. Microbiology	
Department of Microbiology	65
Department of Infection Control and Prevention	71
3. Immunology	
Department of Immunology	76

Radiology and Biomedical Engineering

1. Radiology	
Department of Radiology	82
Department of Radiation Oncology (Experimental Radiology)	88
2. Biomedical Engineering	
Department of System Physiology	93
Department of Bioimaging and Biomagnetics	99
Department of Biosystem Construction & Control	105

Neuroscience

1. Basic Neuroscience	
Department of Neuropathology	111
2. Speech and Cognitive Sciences	
Department of Cognitive Neuroscience	117
3. Clinical Neuroscience	
Department of Neuropsychiatry	120
Department of Neurology	125
Department of Neurosurgery	132

Social Medicine

1. Occupational, Environmental and Preventive Medicine

Department of Molecular Preventive Medicine	138
Department of Public Health	143

2. Forensic Medicine, Medicine Informatics and Economics

Department of Forensic Medicine	148
Department of Medical Informatics and Economics	153

Internal Medicine

1. Medicine I

Department of Cardiovascular Medicine	157
Department of Gastroenterology	164
Department of Nephrology and Endocrinology	170

2. Medicine II

Department of Allergy and Rheumatology	176
Department of Psychosomatic Medicine	182

3. Clinical Laboratory Medicine and Pathology

Department of Clinical Laboratory Medicine	188
Department of Transfusion Medicine	195

Reproductive, Developmental and Aging Sciences

1. Obstetrics and Gynecology

Department of Obstetrics and Gynecology	198
Department of Gynecologic Surgery	202

2. Pediatric Sciences

Department of Pediatrics / Developmental Pediatrics	205
Department of Pediatric Surgery / Department of Pediatric Oncology	211

3. Aging Sciences

Department of Geriatric Medicine / Department of Aging Research	217
---	-----

Surgical Sciences

1. Surgery

Department of Cardiothoracic Surgery	223
Department of Gastrointestinal Surgery / Department of Surgical Metabolism and Nutrition and Endocrine Surgery	228
Department of Hepato-Biliary-Pancreatic Surgery / Department of Artificial Organ and Transplantation	234
Department of Urology	240
Department of Surgical Oncology	245

2. Sensory and Motor System Medicine

Department of Dermatology	250
Department of Plastic and Reconstructive Surgery	255
Department of Oral and Maxillofacial Surgery	258
Department of Orthopaedic Surgery	264
Department of Ophthalmology	271
Department of Otorhinolaryngology, Head and Neck surgery	277
Department of Rehabilitation Medicine	282

3. Vital Care Medicine

Department of Anesthesiology	288
Department of Emergency and Critical Care Medicine	293

Health Sciences and Nursing

1. Health Sciences

Department of Mental Health298
Department Of Social Gerontology303
Department of Health Economics / Health Promotion Sciences / Biomedical Ethics307
Department of Biostatistics / Department of Epidemiology and Preventive Health Sciences311

2. Nursing Sciences

Department of Advanced Clinical Nursing / Department of Nursing Administration316
Department of Adult Nursing/ Terminal and Long-term Care Nursing322
Department of Family Nursing327
Department of Community Health Nursing332

International Health

1. International Social Medicine

Department of International Community Health337

2. International Biomedical Sciences

Department of Human Genetics340
Department of Developmental Medical Sciences344
Department of Human Ecology350
Department of Biomedical Chemistry356

Health Service Center

Department of Organ Pathophysiology and Internal Medicine Health Service Center362

Radiation Research Institute.....368

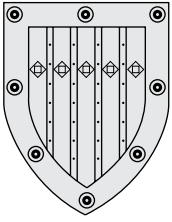

Department of Cell Biology and Anatomy

Outline and Research Objectives

When our institution was reformed from School of Medicine to Graduate School of Medicine, Department of Cell Biology and Anatomy has been built with the transition from the previous department of Anatomy. Therefore, directions of researches in this department are molecular cell biology based on structural cell biology.

At the same time this department has high responsibility for education of medical students, students of other faculties, and master course and Ph.D. course students (totally 518 hours per year). The teaching covers lectures and laboratory courses of gross anatomy, neuroanatomy, histology, cell biology and developmental biology.

Main subjects of researches are focused on 1) the mechanisms of intracellular transport, 2) the mechanism of cell morphogenesis, and 3) roles of cytoskeleton on development.

To solve these problems we combine structural biological approaches such as various kinds of light microscopy, immunocytochemistry, quick freeze deep etch electron microscopy, cryoelectron microscopy, X-ray crystallography with molecular biology, biochemistry, molecular biophysics, electrophysiology and molecular genetics.

Faculties and Students

Professor and Chair	Nobutaka Hirokawa, M. D., Ph.D. (from 1983~)
Associate Professor	Yoshimitsu Kanai, M. D., Ph. D. Takao Nakata, M. D., Ph. D.
Lecturer	Yasuko Noda, M. D., Ph. D. Sumio Terada, M. D., Ph. D.
Associate	8
Postdoctoral Fellow	2 (Japan), 1 (France), 1 (China)
Graduate Students	7 (Japan), 2 (China)
Research Student	3 (China), 1 (Korea)
Secretary & Technician	4

Past Research, Current Research and Major Accomplishments

I. Rapid Freeze Deep Etch Electron Microscopy and Identification of New Groups of Crossbridge Structures Among Microtubules, Intermediate Filaments, Actin and Membranous Organelles.

Hirokawa has developed a new microscopic method which rapidly freeze cells and tissues by making contact with a pure copper block cooled with liquid nitrogen (-190 C) or helium (-269 C) in Japan. He further developed this method in USA with Dr. John Heuser and visualised as yet unknown aspects of specialized membrane structures such as Gap Junction, Tight Junction, and Neuromuscular Junctions. Further he discovered a group of new filamentous cross-bridges among microtubules, intermediate filaments,

actin filaments and membranous organelles. Combining immunocytochemistry, biochemistry, and in vitro reconstitution he proved the chemical nature of these structures as 1) fodrin and myosin in brush borders of intestinal cells, a model of cellular cortex, 2) MAP1A, MAP1B, MAP2 and Tau in microtubule domains in neuronal axon and dendrites, 3) elongated C-terminus of Neurofilament M and H proteins in neurofilament domains in neuronal axons, 4) Synapsin I associated with actin and synaptic vesicles in presynaptic terminals.

II. Discovery of Kinesin Superfamily Proteins, KIFs and Elucidation of Mechanism of Intracellular Transport.

Hirokawa discovered various kinds of new filamentous structures between distinct kinds of membranous organelles and microtubules. He predicted these short crossbridges to be microtubule associated motor proteins carrying cargo vesicles along the microtubules.

The nerve axon is frequently very long (frequently ~1m long). Because of lack of protein synthesis machinery in the axon most of the proteins necessary in the axon and synaptic terminals ought to be transported down the axon as various kinds of membranous organelles and protein complexes after the synthesis in the cell body so that intracellular transport is fundamental for neuronal morphogenesis and functioning. At the same time because similar mechanism exists in every kinds of cells nerve cells serve as a good model system to elucidate this mechanism. Using molecular biology we discovered most of

kinesin superfamily motor proteins, KIFs which move along microtubule rails by hydrolysing ATP. Recently we identified all 45 kif genes in mammalian such as human and mouse. We have uncovered the structure, dynamics and functions of many members of KIFs using molecular cell biological, biophysical, structural biological and molecular genetic approaches.

KIFs in Axonal Transport

KIF1A and KIF1B β transport synaptic vesicle precursors anterogradely from cell body to synaptic terminals. They are fundamental for neuronal functioning and survival. Further, we showed using molecular genetic approaches that KIF1B β is a responsible gene of human hereditary neuropathy Charcot-Marie-Tooth type 2A and proved that CMT2A is due to haploinsufficiency of functional KIF1B β and decrease of synaptic vesicle protein transport.

KIF1B β +/- mice serve as a model for CMT2A and we found a way of diagnosis and potential therapy of the symptom of this disease. KIF1B α and KIF5A, B, C redundantly convey mitochondria anterogradely. KIF3, composed of KIF3A and KIF3B heterodimer and associated protein KAP3, transports vesicles associated with a fodrin and important for neurite elongation through KAP3- α fodrin interaction. KIF2 and KIF4 are expressed specifically in juvenile neurons and functioning for neurite extension.

Receptor Transport in Dendrites

Our studies revealed the mechanism of transport of receptors in dendrites.

KIF17 transports NMDA type glutamate receptor containing vesicles in dendrites toward microtubule plus ends through interaction between KIF17 C-terminal tail-Mint 1 (mLin10)- CASK (mLin2)- Velis (mLin7) and NR2B subunit of NMDA receptor. Furthermore, we showed by transgenic mouse strategy that KIF17 plays a significant role on memory and learning. KIF5A, B, C convey AMPA type glutamate receptor containing vesicles towards microtubule plus end through the interaction between KIF5 heavy chain - GRIP1 (glutamate receptor interacting protein 1)-GluR 2 subunit of AMPA type glutamate receptors.

These studies elucidated also for the first time long standing questions how KIFs recognize and bind to cargoes by showing KIF tail - scaffolding protein complex or adaptor protein complex- membrane protein interaction is a typical way. This idea was supported by our other study revealing that KIF13A transports Mannose 6- phosphate Receptor containing vesicles from Golgi to plasma membrane through the interaction between KIF13A tail - AP-1 adaptor protein complex and Mannose 6 phosphate receptors. Our study about the transport of AMPA type receptor by KIF5 also elucidated a mechanism how motor pro-

tein determines its direction, axon vs dendrites. GRIP1 steers KIF5 to dendrites via KIF5 heavy chain - GRIP1 interaction, while JSAP1 steers KIF5 to axon via KIF5 light chain- JSAP1 interaction.

KIF3 Determines Left-Right Asymmetry of Our Body

Our gene targeting study of KIF3 (KIF3A-/-, and KIF3B-/-) significantly contributed for the elucidation of mechanism of determination of left-right asymmetry of our body, a very important hot problem in developmental biology. Our study uncovered that KIF3 motor is essential for left-right determination of our body through intraciliary transportation of protein complexes for the ciliogenesis of motile primary cilia that generate leftward unidirectional flow of extraembryonic fluid, "nodal flow", which could produce a concentration gradient of putative secreted morphogen in the extraembryonic fluid along the left-right axis in the node of early embryo, very important region for the determination of our body plan.

Mechanism of Motility of Monomeric Motor, KIF1A

We have discovered monomeric motors KIF1 subfamily such as KIF1A, KIF1B α and β . Because motors previously identified are all dimers such as conventional kinesin (KIF5), dyneins and myosin the prevailing hypothesis for how the motor moves processively for certain distance along rails was the hand over hand model, which means a motor needs two legs to move as we walk on the rail. We, however, discovered monomeric motor such as KIF1A. Because the monomeric motor is the simplest motor it is a good model system to study the basic mechanism of motility of KIFs. We showed using molecular biophysics approach that a single KIF1A motor can move processively for more than 1 μ m on microtubules. Furthermore, our study revealed that the processive movement of KIF1A is based on the biased Brownian movement. This is the first clear experimental demonstration showing that motor protein can move by the biased Brownian movement. We further elucidated why single leg motor can move processively along microtubules without dissociation. We found polylysine loop (K-loop) in loop12 and showed that this K-loop is critical for processive movement through the interaction with C-terminal flexible end of tubulin (E-hook) especially at the weak binding state (ADP state) by biophysics, and cryoelectron microscopy.

We further analysed how the plus end bias can be emerged by combination of cryoelectron microscopy and X-ray crystallography. We found that counter clockwise 20 degree rotation of motor domain from ADP to ATP like state is critical for plus end biased



KIF1A transports synaptic vesicle precursor (Okada et al. 1995)

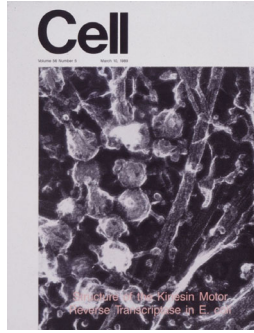

KIF1A transports synaptic vesicle precursor (Okada et al. 1995)

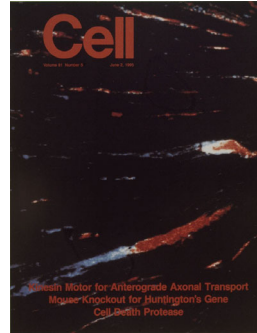

KIF1A transports synaptic vesicle precursor (Okada et al. 1995)

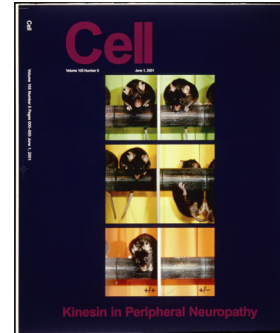

KIF1B is responsible gene of hereditary neuropathy (Zhao et al., 2001)

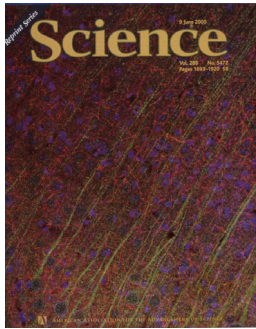

KIF17 transports NMDA receptors (Setou et al. 2000)



Photobleaching recovery study of fluorescent tubulin (Okabe et al. 1990)



Tau induced microtubule bundles and process elongation (Kanai et al. 1989)



Tau/MAP1B double knockout mice (Takei et al. 2000)

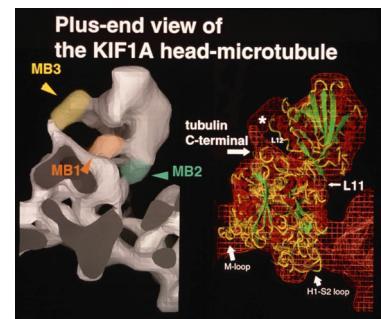
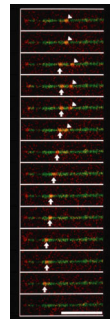
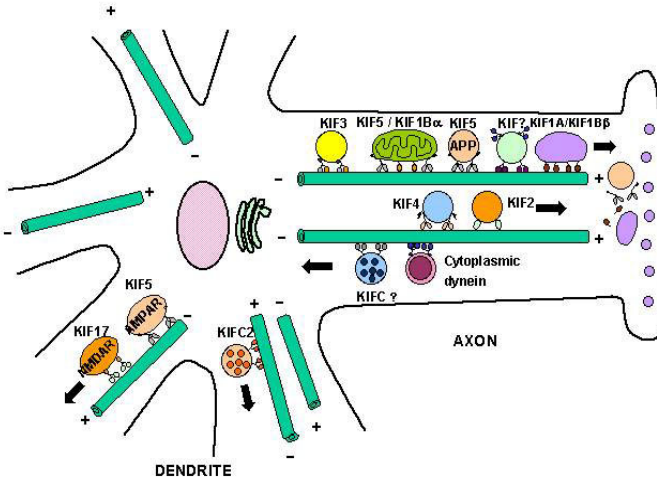

KIF1A monomer moves processively by biased Brownian movement (Okada & Hirokawa Science 1999)

Cryo EM study of KIF1A motor domain-microtubule complex (Kikkawa et al. Cell 2000)

KIFs transport various kinds of cargoes in axon and dendrites

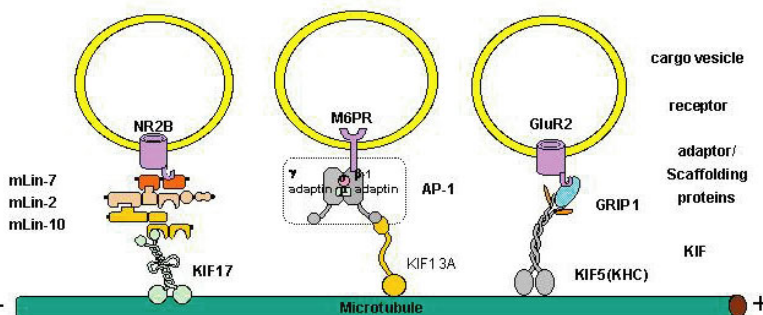

KIFs recognize and bind functional membraneproteins, through KIF tail-scaffolding protein/adaptor protein complex interaction (Setou et al. Science 2000, Nakagawa et al. Cell 2001, Setou et al. Nature 2002)

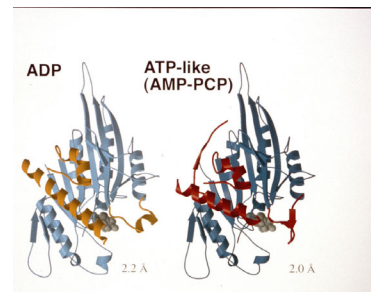

X-ray crystallography and cryoEM study of monomeric KIF1A motor domain (Kikkawa et al. Nature 2001)

movement of KIF1A monomeric motor.

Mechanism of Slow Axonal Transport

Cytoskeletal proteins such as tubulin, actin and neurofilament triplet proteins (NFH, NFM, NFL) and some cytosolic proteins were known to be transported down the axon slowly at 1~2mm/day. Using 1) microinjection of fluorescein labelled cytoskeletal proteins and subsequent analysis by fluorescent photo-bleach recovery, 2) microinjection of caged-fluorescein labelled cytoskeletal proteins and subsequent analysis by UV-photoactivation in cultured neurons we showed most of cytoskeletal proteins such as tubulin and actin are transported as small oligomers. Further, recently using microinjection of fluorescein labelled tubulin and cytosolic proteins into squid giant axons and subsequent analysis with fluorescence confocal laser scanning microscopy and fluorescence correlation spectroscopy combined with microinjection of anti KIF antibodies we demonstrated that tubulin is transported as small oligomers by conventional kinesin (KIF5) as a motor.

III. Microtubule Associated Proteins (MAPs) and Mechanism of Neuronal Morphogenesis.

Hirokawa identified various kinds of filamentous structures associated with microtubules by the quick freeze deep etch electron microscopy. The next questions were what are the chemical nature and what are the functions of these new structures. The microtubule associated proteins (MAPs) identified in brains were good candidates. Therefore, we have studied MAPs. We biochemically isolated major MAPs of mammalian brains such as MAP1A, MAP1B, MAP2 and tau, and studied molecular structure and localization. All these MAPs were filamentous flexible structures from 185 to 50nm in length dependent on the difference of molecular weight. Immunocytochemistry and in vitro reconstitution confirmed that these MAPs are components of filamentous structures associated with microtubules in neurons. To know the function of MAPs, we expressed tau and MAP2 in non neuronal cells such as fibroblasts and Sf9 cells by cDNA transfection. These studies showed that tau and MAP2 induce microtubule polymerization and bundling and process extension. They also revealed that C-terminal domain are critical for microtubule polymerization and N-terminal projection domain determines the different spacings between adjacent microtubules in microtubule domains in axon vs dendrites. These data suggest the important role of tau and MAP2 in formation of axon and dendrites. In order to elucidate function of MAPs in vivo we generated single knockout mice of tau, MAP1B, and MAP2 and analysed them. Generally, the phenotypes of single knockout mice were subtle. However, tau/MAP1B

and MAP2/MAP1B double knockout mice showed predominant disturbance of axonal elongation and dendritic elongation respectively. Cellular bases of these phenotypes are suppression of microtubule stability and bundle formation in growth cones of axon and dendrites leading to the inhibition of proper neurite extension and neuronal cell migration. Thus, our studies revealed Tau/MAP1B and MAP2/MAP1B synergistically play fundamental roles in axonal and dendritic formation respectively.

Future Prospects

The further studies in near future will include following subjects as the continuation of on going researches.

I. Mechanism of Intracellular Transport

- 1) The functions of new KIFs especially in neurons, epithelial cells and fibroblasts to elucidate yet unknown mechanism of intracellular transport of various kinds of membranous organelles, protein complexes and mRNA.
- 2) Understanding how each KIFs recognize and bind their specific cargoes.
- 3) The studies how the binding and unbinding of KIFs with cargoes are regulated.
- 4) The mechanism how neurons determine the direction of transport by KIFs, toward axon vs dendrites.
- 5) The study of relationship between KIFs and neuronal functions such as memory and learning by molecular genetic approach.
- 6) The relationship between KIFs and diseases using molecular genetical approaches.
- 7) The detailed mechanism of motility of KIF1A motor using structural biology and molecular biophysics.

II. Mechanism of Neuronal Morphogenesis and MAPs

Using molecular genetical approaches we will unravel the function of MAP1A, one member of major MAPs whose function has been unknown.

Research Grants

1. Center of Excellence (COE) grant from the Ministry of Education, Culture, Science and Sports, "Molecular Cell Biological and Molecular Genetical Study of the Cytoskeleton: Mechanism of Intracellular Transport, Signal Transmission and Cellular Morphogenesis." From April 1996 to March 2001. 1,885,000,000 yen
2. Grant in Aid for Basic Research, "Molecular Cell Biology of New Molecular Motors, KIFs," from the Ministry of Education, Culture, Science and Sports. From April 1996 to March 1999. 34,500,000 yen
3. Center of Excellence (COE) grant from the Ministry of Education, Culture, Science, Sports and Technology, "Mechanism of Intracellular Transport

:Molecular Cell Biology, Structure Biology and Molecular Genetics."From April 2001 to March 2006. 2,020,000,000 yen

Publication list

1. Hirokawa N and Kirino T. An ultrastructural study of nerve and glia cells by freeze-substitution. *Journal of Neurocytology* 9, 243-254, 1980.
2. Hirokawa N. Crosslinker system between neurofilaments, microtubules and membranous organelles in frog axons revealed by quick freeze, freeze fracture, deep etching method. *Journal of Cell Biology* 94, 129-142, 1982.
3. Hirokawa N, and Heuser J. E. The inside and outside of gap junction membranes visualized by deep etching. *Cell* 30, 395-406, 1982.
4. Hirokawa N, Cheney R, and Willard M B. Location of a protein of the fodrin-spectrin-TW 260/240 family in the mouse intestinal brush border. *Cell* 32, 953-965, 1983.
5. Hirokawa N, M. A. Glicksman, and M. B. Willard. Organization of mammalian neurofilament polypeptides within the neuronal cytoskeleton. *Journal of Cell Biology* 98, 1523-1536, 1984.
6. Shiomura Y and Hirokawa N. The molecular structure of microtubule-associated protein 1A (MAP1A) in vivo and in vitro. An immunoelectron microscopy and quick-freeze, deep-etch study. *Journal of Neuroscience* 7, 1461-1469, 1987.
7. Hirokawa N, Hisanaga S and Shiomura Y. MAP2 is a component of crossbridges between microtubules and neurofilaments in vivo and in vitro. Quick-freeze, deep etch immunoelectron microscopy and reconstitution studies. *Journal of Neuroscience* 8, 2769-2779, 1988.
8. Hirokawa N, Pfister K K, Yorifuji H, Wagner MC, Brady S T and Bloom GS. Submolecular domains of bovine brain kinesin identified by electron microscopy and monoclonal antibody decoration. *Cell* 56, 867-878, 1989.
9. Kanai Y, Takemura R, Ohshima T, Mori H, Ihara Y, Yanagisawa M, Masaki T and Hirokawa N. Expression of multiple tau isoforms and microtubule bundle formation in fibroblasts transfected with a single tau cDNA. *Journal of Cell Biology* 109, 1173-1184, 1989.
10. Sato-Yoshitake R, Shiomura Y, Miyasaka H and Hirokawa N. Microtubule-associated protein 1B: Molecular structure, localization, and its phosphorylation-dependent expression in developing neurons. *Neuron* 3, 229-238, 1989.
11. Okabe S and Hirokawa N. Turnover of fluorescently labeled tubulin and actin in the axon. *Nature* 343, 479-482, 1990.
12. Hirokawa N, Yoshida T, Sato-Yoshitake R, and Kawashima T. Brain dynein (MAP1C) localizes on both anterogradely and retrogradely transported membranous organelles. *Journal of Cell Biology* 111, 1027-1037, 1990.
13. Hirokawa N, Sato-Yoshitake R, Kobayashi N, Pfister KK, Bloom GH, and Brady ST. Kinesin associates with anterogradely transported membranous organelles in vivo. *Journal of Cell Biology* 114, 295-302, 1991.
14. Aizawa H, Sekine Y, Takemura R, Zhang Z, Nangaku M and Hirokawa N. Kinesin family in murine central nervous system. *Journal of Cell Biology* 119, 1287-1296, 1992.
15. Chen J, Kanai Y, Cowan NJ and Hirokawa N. Projection domains of MAP2 and tau determine spacings between microtubules in dendrites and axons. *Nature* 360, 674-677, 1992.
16. Hirokawa N. Microtubule organization and dynamics dependent on microtubule-associated proteins. *Current Opinion in Cell Biology* 6, 74-82, 1994.
17. Harada A, Oguchi K, Okabe S, Kuno J, Terada S, Ohshima T, Sato-Yoshitake R, Takei Y, Noda T and Hirokawa N. Altered microtubule organization in small-calibre axons of mice lacking tau protein. *Nature* 369, 488-491, 1994.
18. Kondo S, Sato-Yoshitake R, Noda Y, Aizawa H, Nakata T, Matsuura Y and Hirokawa N. KIF3A is a new microtubules-based anterograde motor in the nerve axon. *Journal of Cell Biology* 125, 1095-1107, 1994.
19. Sekine Y, Okada Y, Kondo S, Aizawa H, Takemura R and Hirokawa N. A novel microtubule-based motor protein (KIF4) for organelle transports, whose expression is regulated developmentally. *Journal of Cell Biology* 127, 187-202, 1994.
20. Nangaku M, Sato-Yoshitake R, Okada Y, Noda Y, Takemura R, Yamazaki H, and Hirokawa N. KIF1B; A novel microtubule plus end-directed monomeric motor protein for transport of mitochondria. *Cell* 79, 1209-1220, 1994.
21. Noda Y, Sato-Yoshitake R, Kondo S, Nangaku M and Hirokawa N. KIF2 is a new microtubule-based anterograde motor that transports membranous organelles distinct from those carried by kinesin heavy chain or KIF3A/B. *Journal of Cell Biology* 129, 157-167, 1995.
22. Okada Y, Yamazaki H, Sekine Y, and Hirokawa N. The neuron-specific kinesin superfamily protein KIF1A is a unique monomeric motor for anterograde axonal transport of synaptic vesicle precursors. *Cell* 81, 769-780, 1995.
23. Kikkawa M, Ishikawa T, Wakabayashi T and Hirokawa N. Three-dimensional structure of the kinesin head-microtubule complex. *Nature* 376, 274-276, 1995.
24. Yamazaki H, Nakata T, Okada Y, and Hirokawa N. KIF3A/B: A heterodimeric kinesin superfamily protein that works as a microtubule plus end-directed motor for membrane organelle transport. *Journal of Cell Biology* 130, 1387-1399, 1995.
25. Hirokawa N. Organelle transport along microtubules—the role of KIFs (Kinesin superfamily proteins). *Trends in Cell Biology* 6, 135-141, 1996.

26. Terada S, Nakata T, Peterson A and Hirokawa N. Visualization of slow axonal transport in vivo. *Science* 273, 784-788, 1996.
27. Saito N, Okada Y, Noda Y, Kinoshita Y, Kondo S and Hirokawa N. KIFC2 is a novel neuron-specific C-terminal type kinesin superfamily motor for dendritic transport of multivesicular body-like organelles. *Neuron* 18, 425-438, 1997.
28. Takei Y, Kondo S, Harada A, Inomata S, Noda T and Hirokawa N. Delayed development of nervous system in mice homozygous for disrupted microtubule-associated protein 1B (MAP1B) gene. *Journal of Cell Biology* 137, 1615-1626, 1997.
29. Hirokawa N. Kinesin and dynein superfamily proteins and the mechanism of organelle transport. *Science* 279, 519-526, 1998.
30. Nakata T, Terada S and Hirokawa N. Visualization of the dynamics of synaptic vesicle and plasma membrane proteins in living axons. *Journal of Cell Biology* 140, 659-674, 1998.
31. Yonekawa Y, Harada A, Okada Y, Kanai Y, Takei Y, Funakoshi T, Terada S, Noda T and Hirokawa N. Defect in synaptic vesicle precursor transport and neuronal cell death in KIF1A motor protein-deficient mice. *Journal of Cell Biology* 141, 431-441, 1998.
32. Tanaka Y, Kanai Y, Okada Y, Nonaka S, Takeda S, Harada A and Hirokawa N. Targeted disruption of mouse conventional kinesin heavy chain, KIF5B, results in abnormal perinuclear clustering of mitochondria. *Cell* 93, 1147-1158, 1998.
33. Nonaka S, Tanaka Y, Okada Y, Takeda S, Harada A, Kanai Y, Kido M and Hirokawa N. Randomization of left-right asymmetry due to loss of nodal cilia generating leftward flow of extraembryonic fluid in mice lacking KIF3B motor protein. *Cell* 95, 829-837, 1998.
34. Okada Y and Hirokawa N. A processive single-headed motor: kinesin superfamily protein, KIF1A. *Science* 283, 1152-1157, 1999.
35. Takeda S, Yonekawa Y, Tanaka Y, Okada Y, Nonaka S and Hirokawa N. Left-right asymmetry and kinesin superfamily protein KIF3A: New insights in determination of laterality and mesoderm induction by Kif3A^{-/-} mice analyses. *Journal of Cell Biology* 145, 825-836, 1999.
36. Okada Y, Nonaka S, Tanaka Y, Saijoh Y, Hamada H and Hirokawa N. Abnormal nodal flow precedes situs inversus in *iv* and *inv* mice. *Molecular Cell* 4, 459-468, 1999.
37. Okada Y and Hirokawa N. Mechanism of the single-headed processivity : Diffusional anchoring between "k-loop" of kinesin and the C-terminus of tubulin. *Proceedings of the National Academy of Science of the USA* 97, 640-645, 2000.
38. Kikkawa M, Okada Y and Hirokawa N. 15Å resolution model of the monomeric kinesin motor: KIF1A. *Cell* 100, 241-252, 2000.
39. Takeda S, Yamazaki H, Seog D-H, Kanai Y, Terada S and Hirokawa N. KIF3 motor transports fodrin-associating vesicles important for neurite building. *Journal of Cell Biology* 148, 1255-1266, 2000.
40. Setou M, Nakagawa T, Seog D-H and Hirokawa N. Kinesin superfamily motor protein KIF17 and mLin-10 in NMDA receptor-containing vesicle transport. *Science* 288, 1796-1802, 2000.
41. Takei Y, Teng J, Harada A and Hirokawa N. Defects in axonal elongation and neuronal migration in mice with disrupted tau and map1b genes. *Journal of Cell Biology* 150, 989-1000, 2000.
42. Terada S, Kinjo M and Hirokawa N. Oligomeric tubulin in large transporting complex is transported via kinesin in squid giant axons. *Cell* 103, 141-155, 2000.
43. Nakagawa T, Setou M, Seog D-H, Ogasawara K, Dohmae N, Takio K and Hirokawa N. A novel kinesin superfamily motor, KIF13A, transports mannose-6-phosphate receptor to plasma membrane through direct interaction with AP-1 complex. *Cell* 10, 569-581, 2000.
44. Kikkawa M, Sablin EP, Okada Y, Yajima H, Fletterick RJ and Hirokawa N. Switch-based mechanism of kinesin motors. *Nature* 411, 439 - 445, 2001.
45. Zhao C, Takita J, Tanaka Y, Setou M, Nakagawa T, Takeda S, Hong W-Y, Terada S, Nakata T, Takei Y, Saito M, Tsuji S, Hayashi Y and Hirokawa N. Charcot-Marie-Tooth Disease type 2A caused by mutation in a microtubule motor KIF1Bβ. *Cell* 105, 587-597, 2001.
46. Miki H, Setou M, Kanashiro K and Hirokawa N. All kinesin superfamily protein, KIF, genes in mouse and human. *Proceedings of the National Academy of Science of the USA* 98, 7004-7011, 2001.
47. Teng J, Takei Y, Harada A, Nakata T, Chen J and Hirokawa N. Synergistic effects of MAP2 and MAP1B knockout in neuronal migration, dendritic outgrowth, and microtubule organization. *Journal of Cell Biology* 15, 65-76, 2001.
48. Noda Y, Okada Y, Saito N, Setou M, Xu Y, Zhang Z and Hirokawa N. KIFC3, a microtubule minus end-directed motor for the apical transport of annexin XIIIb-associated Triton-insoluble membranes. *Journal of Cell Biology* 155, 77-88, 2001.
49. Setou M, Seog D-H, Tanaka Y, Kanai Y, Takei Y, Kawagishi M and Hirokawa N. Glutamate-receptor-interacting protein GRIP1 directly steers kinesin to dendrites. *Nature* 417, 83-87, 2002.
50. Harada A, Teng J, Takei Y, Oguchi K and Hirokawa N. MAP2 is required for dendrite elongation, PKA anchoring in dendrites, and proper PKA signal transduction. *Journal of Cell Biology* 15, 541-549, 2002.

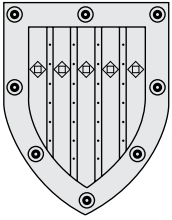

Department of Molecular Biology

Outline and Research Objectives

This department was established in 1893 as the first Biochemistry Department in Japan. Since then, this department has been devoted to biochemical studies on vitamin, oxidative phosphorylation, lipid, carbohydrate and nucleic acid metabolisms, making remarkable contributions to advancements in medical biochemistry. After H. Okayama succeeded Chair in 1992, research has been focused on cancer, the cell cycle and differentiation in order to understand the molecular mechanism of malignant transformation and growth control.

Faculties and Students

Professor and Chair	Hiroto Okayama, MD & PhD (1992~)
Associate3
Postdoctoral Fellow1
Graduate Student5
Research Student5
Secretary2

Past Research and Major Accomplishments

Development of high-efficiency full-length cDNA cloning method and eukaryotic expression cDNA cloning system

Most of our past and current research stemmed from the development of the full-length cDNA cloning method and the cDNA expression cloning vector system that was done in the early 1980s by Hiroto Okayama and Paul Berg (Fig. 1)(1,2).

The full-length cDNA cloning method and the cDNA expression libraries constructed thereby have been used to clone numerous functional genes in laboratories over the world, the earliest one of which is the human Lesch-Nyhan syndrome causative gene (3). The cDNA expression cloning vector system was originally designed to clone genes on the basis of the

functions they express in a wide range of host cells, from fission yeast up to mammalian cells. This was enabled by development of highly efficient methods for introducing cDNA libraries into mammalian cells and fission yeast and construction of vectors specialized for library transduction into fission yeast (Fig. 1) (8, 10, 11). One of the most successful applications of this expression cloning system was isolation of human orthologues of several key cell cycle regulators initially found in fission yeast. Paul Nurse cloned the human *cdc2* cDNA from one of our expression libraries on the basis of trans-complementation of a fission yeast temperature-sensitive mutant of *cdc2*⁺ essential for mitosis, and we cloned human orthologues of *wee1*⁺ and *cdc25*⁺ genes (13, 14), which critically regulate Cdc2 kinase during this transition, as described below.

Cell cycle control

Cdc2 kinase is a protein kinase required for the onset of mitosis, initially found in fission yeast, but present in all eukaryotes. This kinase, associated with cyclins, is regulated by inhibitory tyrosine phosphorylation and activating dephosphorylation by Wee1 kinase and Cdc25 phosphatase, constituting a core element of DNA damage-responsive cell cycle checkpoint control for the G₂-M transition in fission yeast.

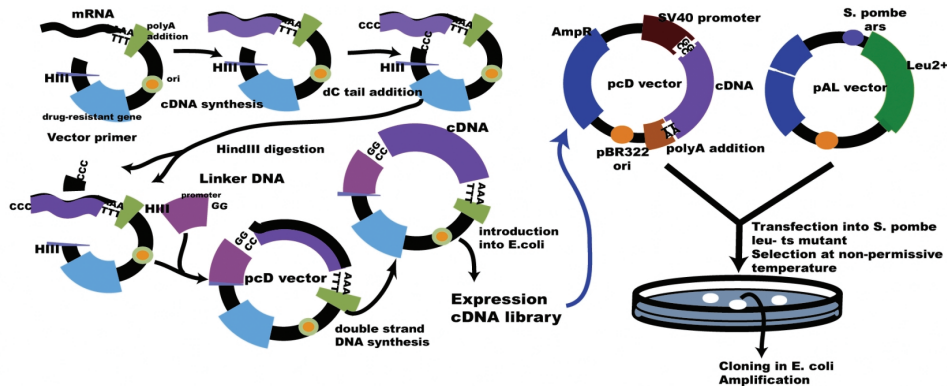

Fig.1. Methods for construction of full-length expression cDNA librareis and trans-complementation cloning with fission yeast as host

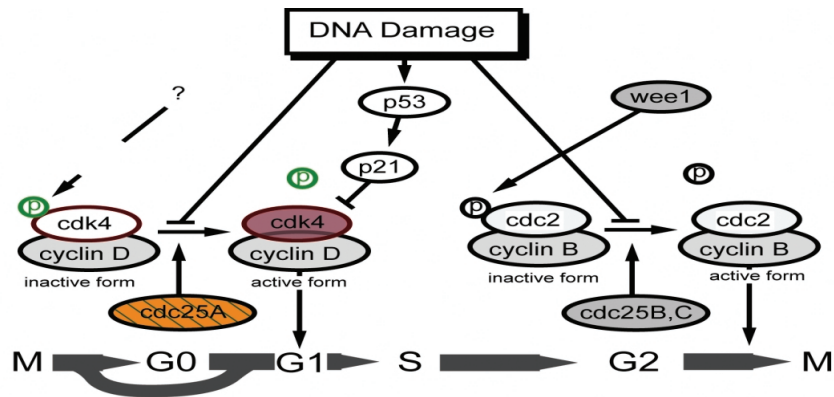

Fig. 2. Similarity in DNA damage-invoked G1/G2 checkpoint control

The identification of human orthologues (cdc2, wee1 and cdc25B) of these fission yeast cell cycle regulators demonstrated the evolutionary conservation of a cell cycle control system up to mammals (13, 14, 30). Using the same expression cloning system, we also identified an additional mammalian homologue (cdc25A) of *cdc25⁺* gene, which was found to play an unexpected role (23).

This gene is expressed in early G₁ and required for the cell cycle start. Search for targets for this novel phosphatase led us to discover that Cdk4, a cyclin-dependent kinase essential for the cell cycle start, is regulated by tyrosine phosphorylation and that its regulation constitutes a key part of DNA damage-induced G₁ checkpoint arrest during cell cycle entry from quiescence (23, 28, 37), revealing the presence of mirror image mechanisms for controlling DNA damage-responsive G₁ and G₂ checkpoint arrest in mammals (Fig. 2).

In addition to the studies on mammalian cell cycle control, we identified genes for 11 fission yeast novel cell cycle factors and cyclin G a novel mammalian cyclin (22), which control the G₁-S transition, DNA-replication checkpoint or the formation and maintenance of sister chromatid cohesion (20, 24-27, 29, 33, 35, 40, 42-44, 48). Recent studies on two newly identified factors Eso1 and Pds5 involved in the formation of sister chromatid cohesion led us to discover that sister chromatid cohesion is formed and maintained by a highly unexpected mechanism, which functions as a molecular zipper and thereby promotes the formation of cohesions only between sister chromatids (48). This finding provided a new clue to the understanding of the mechanism for the genetic instability associated with malignant transformation.

Differentiation control

One of the aspects of the cell we have been interested in understanding concerning carcinogenesis is differentiation control. To this end, we also used fission yeast as a model organism and discovered five novel genes controlling the commitment to differenti-

ation. They encode Esc1 a MyoD-like helix-loop-helix protein, Nrd1 an RNA-binding protein, Phh1 a stress MAP kinase similar to p38, Rcd1 an evolutionally conserved protein and Pas1 and Cyc17 novel cyclins (21, 26, 31, 33, 36, 43, 44). These proteins were found to be a modifier of cyclin AMP signaling, a determinant of the threshold to nutrient starvation for the commitment to differentiation, a stress signal transducer as an absolute requirement for the differentiation commitment, a key mediator of nitrogen starvation signal and factors that ensure mutual exclusiveness between the cell cycle start and the commitment to differentiation. In addition, using trans-complementation cloning, we isolated a human functional counterpart of the RNA-binding protein with predicted functions, which were shown in hematopoietic cells (38).

Furthermore, we recently found that the mammalian counterpart of Rcd1 is a novel transcriptional cofactor mediating retinoic acid-induced cell differentiation and is deeply involved in mouse lung development (50). These findings not only reveal remarkable conservation of the differentiation commitment system as well as the key elements that control the commitment step from yeast up to mammals (Fig. 3), but also greatly help understand the highly complex mechanism controlling the differentiation commitment in mammals.

Anchorage-independent cell cycle start: a key mechanism for malignant transformation

One of the fundamental phenotypes that distinguish malignant from benign cells is the metastatic capability, which is underlain by the acquirement of the ability to perform S phase entry in the absence of anchorage. In the late 1980s, we began studies to understand the nature and mechanism of the acquirement of this unique property upon malignant transformation, by using growth factor-transformable NRK cells as a model system. The generally held concept was that anchorage-independent S phase entry is a mere consequence of excessive activation of growth signaling or defects in a growth arrest system, which

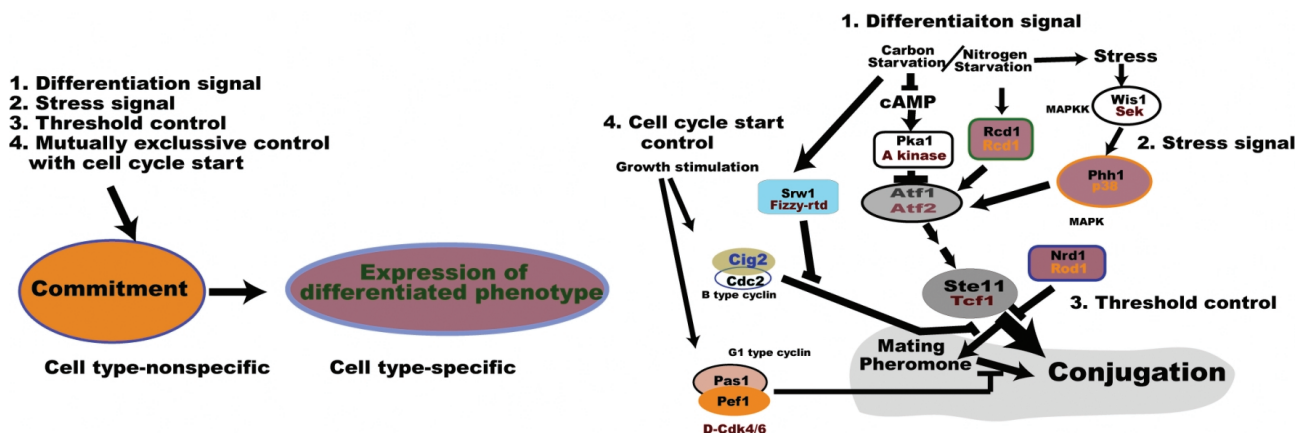

Fig. 3. Elements and evolutionary conservation of eukaryotic differentiation commitment control

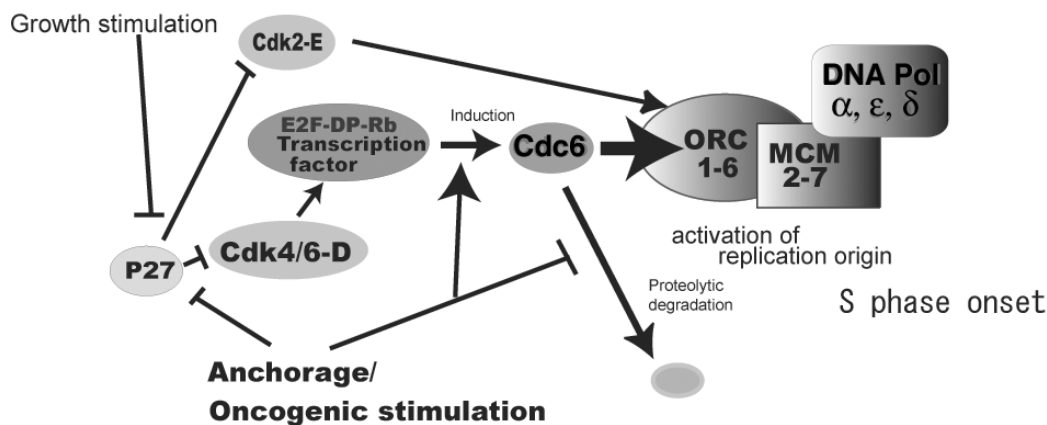

Fig.4. Cell cycle start control by anchorage

are caused by activation of oncogenes and inactivation of recessive oncogenes. For the past 10 years, we studied genetically and cytologically the properties of oncogenically stimulated NRK cells and came to the several remarkable conclusions: 1) In NRK cells, epidermal growth factor and platelet-derived growth factor signals merge into a common pathway composed of CrkII, Ras and Raf-1, through which many oncogenes induce transformation; 2) Activation of this pathway induces anchorage-independent S phase entry in a synchronized fashion, but is dispensable for cell proliferation in the presence of anchorage; 3) Oncogenic stimulation recruits Cdk6 to participate in an essential step of anchorage-independent S phase onset; 4) Activation of G₁ cyclin-dependent kinases (Cdk4/6, Cdk2) is insufficient to induce anchorage-independent S phase onset (15, 16, 32, 39). Recently, we found that Cdc6, a key protein for the activation of replication origins, requires anchorage or oncogenic stimulation for its expression, which is regulated at the levels of transcription and proteolysis via a calpain-like protease, and moreover, that G₁ cyclin-dependent kinases and Cdc6 constitute key targets for controlling the G₁-S transition by anchorage and oncogenic signals (Fig. 4)(49).

We believe that this latest finding would provide a

major breakthrough toward the understanding of the mechanisms for anchorage loss-invoked restriction of S phase onset and oncogenically induced anchorage-independent S phase onset, the latter being responsible for the metastatic capability of malignant cells. In addition, all these findings taken together raise the possibility that oncogenic transformation is not merely resulted from a failure to arrest due to excessive growth stimulation or defective cell cycle arrest systems, but from constitutive activation of a dormant mechanism that is present in normal cells and enables the cell cycle start in the absence of anchorage (46).

Current Research

We are currently devoting most of our efforts to the understanding of how Cdc6 expression is regulated by anchorage and oncogenic signals.

Requirement for PI3 kinase in Cdc6 expression

It has been known that phosphoinositol-3 (PI3) kinase is required for the cell cycle start and one of its targets is p27 cyclin-dependent kinase inhibitor. We recently found that entirely independent from p27 downregulation, Cdc6 requires PI3 kinase for its expression during anchorage-dependent, but not

anchorage-independent, S phase entry. Treatment of cells with a specific PI3 kinase inhibitor shuts off Cdc6 expression despite E2F activation, but interestingly this shutoff is overridden by oncogenic stimulation. Further analysis is underway to identify how PI3 kinase and anchorage signal cooperate to express Cdc6.

Identification of the protease responsible for the Cdc6 degradation and its regulation

The most crucial point in understanding the regulatory mechanism of Cdc6 expression by anchorage and oncogenic stimulation is identification of the responsible protease and its regulatory mechanism (Fig.4). To this end, a human cdc6 cDNA was isolated, tagged with a histidine tag and transcribed in vitro and expressed in reticulocyte lysates, and the expressed His-tagged Cdc6 protein was purified by affinity chromatography in order to establish an in vitro assay system. Analysis of the nature of the putative protease suggests that the cells arrested in G₁ by anchorage loss contain the proteolytic activity that seems to be responsible for Cdc6 degradation. Analysis of the nature of this protease and its regulation is currently in progress.

Cdk6-cyclin D3 as a highly potent sensitizer of cells to chemical and physical transformation

We recently found that among D-type cyclin (D1, D2, D3) and partner kinase (Cdk4, Cdk6) combinations, the Cdk6-D3 complex is unique and can evade inhibition by p27 and p21, consequently enabling this complex to control proliferation competence under growth suppressive conditions (47). This finding led us to investigate the possible effects of the elevated expression of this complex on cell's susceptibility to malignant transformation, and we have found that 2-5 fold overexpression of Cdk6-D3 elevates 10³-10⁶ folds the susceptibility of rodent fibroblasts to UV irradiation- or 3-methylcholanthrene-induced malignant transformation. Analysis is in progress to understand this sensitization mechanism.

Future Prospects

There are three key questions regarding malignant transformation: 1) What is the mechanism by which transformed cells acquire the ability to perform anchorage-independent S phase onset as a basis for metastatic capability?; 2) What causes the genetic instability of cancer, which is believed to be a driving force for malignant progression and what are the key cell cycle factors activated or inactivated during this process?; 3) What is the mechanism for dedifferentiation of malignant cells? We believe that the series of our research will certainly offer critical clues to solve

these questions. We particularly believe that the finding that Cdc6, a key factor for the activation of replication origins, absolutely requires anchorage or oncogenic stimulation for its expression is a major breakthrough to understanding the central mechanism of oncogenically induced anchorage-independent S phase onset.

Research Grants

1. H. Okayama, Grant-in-Aid for Scientific Research (A), JSPS, 1992-present. ¥10,000,000 a year.
2. H. Okayama, Grant-in-Aid for Scientific Research on Priority Areas "Advanced Cancer Research", MEXT, 1992-1999. ¥32,000,000 a year.
3. H. Okayama, Grant-in-Aid for Scientific Research on Priority Areas "Cell Cycle Control", MEXT, 2000-present. ¥60,000,000 a year.

Select Publications

1. Okayama, H., and Berg, P. High efficiency cloning of full length cDNA. *Mol. Cell. Biol.* 2, 161-170, 1982.
2. Okayama, H., and Berg, P. A cDNA cloning vector that permits expression of cDNA inserts in mammalian cells. *Mol. Cell. Biol.* 3, 280-289, 1983.
3. Jolly, D. J., Okayama, H., Berg, P., Esty, A. C., Filpula, D., Bohlen, P., Johnson, G., and Friedman, T. Isolation and characterization of a full length, expressible cDNA for human hypoxanthine guanine phosphoribosyl transferase. *Proc. Natl. Acad. Sci. USA* 80, 477-481, 1983.
4. Chin, D. J., Gil, G., Russell, D. W., Liscum, L., Luskey, K., Basu, S., Okayama, H., Berg, P., Goldstein, J. L., and Brown, M. Nucleotide sequence of 3-hydroxy-3-methyl-glutaryl coenzyme A reductase, a glycoprotein of endoplasmic reticulum. *Nature* 308, 613-617, 1984.
5. Yang, Y.-C., Okayama, H., and Howley, P. Bovine papillomavirus contains multiple transforming genes. *Proc. Natl. Acad. Sci. USA* 82, 1030-1034, 1985.
6. Okayama, H., Kawaiichi, M., Brownstein, M., Lee, F., Yokota, T., and Arai, K. High-efficiency cloning of full length cDNA; Construction and screening of cDNA expression libraries for mammalian cells. *Methods Enz.* 154, 3-28, 1987.
7. Chen, C., and Okayama, H. High-efficiency transformation of mammalian cells by plasmid DNA. *Mol. Cell. Biol.* 7, 2745-2752, 1987.
8. Okayama, H., and Chen, C. Calcium phosphate mediated gene transfer into established cell lines. *Methods Mol. Biol.* pp. 15-21, 1990.
9. Tanaka, K., Miura, N., Satokata, I., Miyamoto, I., Yoshida, M., Sato, Y., Kondo, S., Yasui, A., Okayama, H., and Okada, Y. A cDNA sequence of xeroderma pigmentosum group A gene encoding a protein with zinc finger structure. *Nature* 348, 73-76, 1990.

10. Inoue, H., Nojima, H., and Okayama, H. High efficiency transformation of *Escherichia coli* with plasmids. *Gene* 96, 23-28, 1990.
11. Okazaki, K., Okazaki, N., Kume, K., Jinno, S., Tanaka, K., and Okayama, H. High-frequency transformation method and library transducing vectors for cloning mammalian cDNAs by trans-complementation of *Schizosaccharomyces pombe*. *Nuc. Acids Res.* 18, 6485-6489, 1990.
12. Takamizawa, A., Mori, C., Fuke, I., Manabe, S., Murakami, S., Fujita, J., Onishi, E., Andoh, T., Yoshida, I., and Okayama, H. Structure and organization of the hepatitis C virus genome isolated from human carriers. *J. Virol.* 65, 1105-1113, 1991.
13. Nagata, A., Igarashi, M., Jinno, S., Suto, K., and Okayama, H. An additional homolog of the fission yeast *cdc25+* gene occurs in human and is highly expressed in some cancer cells. *New Biologist* 3, 959-968, 1991.
14. Igarashi, M., Nagata, A., Jinno, S., Suto, K., and Okayama, H. *Wee1+*-like gene in human cells *Nature* 353, 80-83, 1991.
15. Masuda, A., Kizaka-Kondoh, S., Miwatani, H., Terada, Y., Nojima, H., and Okayama, H. Signal transduction cascade shared by epidermal growth factor and platelet-derived growth factor is a major pathway for oncogenic transformation in NRK cells. *New Biologist* 4, 489-503, 1992.
16. Kume, K., Jinno, S., Miwatani, H., Kizaka-Kondoh, S., Terada, Y., Nojima, H., and Okayama, H. Oncogenic signal-induced ability to enter S phase in the absence of anchorage is the mechanism for the growth of transformed NRK cells in soft agar. *New Biologist* 4, 504-511, 1992.
17. Kimura, T., Tanizawa, O., Mori, K., Brownstein, M., and Okayama, H. Structure and expression of a human oxytocin receptor. *Nature* 356, 526-529, 1992.
18. Tatsuka, M., Mitsui, H., Wada, M., Nagata, A., Nojima, H., and Okayama, H. Elongation factor-1a gene determines susceptibility to transformation. *Nature* 359, 333-336, 1992.
19. Kizaka-Kondoh, S., Sato, K., Tamura, K., Nojima, H., and Okayama, H. Raf-1 protein kinase is an integral component of the oncogenic signal cascade shared by epidermal growth factor and platelet-derived growth factor. *Mol. Cell. Biol.* 12, 5078-5086, 1992.
20. Tanaka, K., Okazaki, K., Okazaki, N., Ueda, T., Sugiyama, A., Nojima, H. and Okayama, H. A new *cdc* gene required for S phase entry of *Schizosaccharomyces pombe* encodes a protein similar to the *cdc10+* and *SWI4* gene products. *EMBO J.* 11, 4923-4932, 1992.
21. Benton, B. K., Reid, M. S. and Okayama, H. A *Schizosaccharomyces pombe* gene that promotes sexual differentiation encodes a helix - loop - helix protein with homology to MyoD. *EMBO J.* 12, 135-143, 1993.
22. Tamura, K., Kanaoka, Y., Jinno, S., Nagata, A., Ogiso, Y., Shimizu, K., Hayakawa, T., Nojima, H., and Okayama, H. Cyclin G: A new mammalian cyclin with a potential tyrosine phosphorylation site. *Oncogene* 8, 2113-2118, 1993.
23. Jinno, S., Suto, K., Nagata, A., Igarashi, M., Kanaoka, Y., Nojima, H., and Okayama, H. *Cdc25A* is a novel phosphatase functioning early in the cell cycle. *EMBO J.* 13, 1549-1556, 1994.
24. Sugiyama, A., Tanaka, K., Okazaki, K., Nojima, H., and Okayama, H. A zinc finger protein controls the onset of premeiotic DNA synthesis of fission yeast in a *Mei2*-independent cascade. *EMBO J.* 13, 1881-1887, 1994.
25. Miyamoto, M., Tanaka, K., and Okayama, H. *res2+*, a new member of *cdc10+/SWI4* family, controls the ∞ start ∞ h of mitotic and meiotic cycles in fission yeast. *EMBO J.* 13, 1873-1880, 1994.
26. Obara-Ishihara, T., and Okayama, H. A B-type cyclin regulates conjugation via interaction with cell cycle "start" genes in fission yeast. *EMBO J.* 13, 1863-1872, 1994.
27. Murakami, H., and Okayama, H. A kinase from fission yeast responsible for blocking mitosis in S phase. *Nature* 374, 817-819, 1995.
28. Terada, Y., Tatsuka, M., Jinno, S., and Okayama, H. Requirement for tyrosine phosphorylation of Cdk4 in G1 arrest induced by ultraviolet irradiation. *Nature* 367, 358-362, 1995.
29. Nakashima, N., Tanaka, K., Sturm, S., and Okayama, H. Fission Yeast Rep2 is a putative transcriptional activator subunit for the cell cycle "start" function of *Res2-Cdc10*. *EMBO J.* 14, 4794-4802, 1995.
30. Okayama, H., Nagata, A., Jinno, S., Murakami, H., Tanaka, K., and Nakashima, N. Cell cycle control in fission yeast and mammals identification of new regulatory mechanisms. 1996, *Adv. Cancer Re.* 69, 17-62.
31. Kato, Jr., T., Okazaki, K., Murakami, H., Stettler, S., Fantes, A., P., and Okayama, H. Stress signal, mediated by a Hog1-like MAP kinase, controls sexual development in fission yeast. *FEBS Let.* 378, 207-212, 1996.
32. Kizaka-Kondoh, S., Matsuda, M., and Okayama, H. CrkII signals from epidermal growth factor receptor to Ras. *Proc. Natl. Acad. Sci. USA* 93, 12177-12182, 1996.
33. Yamaguchi, S., Murakami, H., and Okayama, H. A WD repeat protein controls the cell cycle and differentiation by negatively regulating Cdc2/B-type cyclin complexes. *Mol. Biol. Cell* 8, 2475-2486, 1997.
34. Okazaki, N., Okazaki, K., Watanabe, Y., Kato-Hayashi, M., Yamamoto, M., and Okayama, H. Novel factor highly conserved among eukaryotes controls sexual development in fission yeast. *Mol. Cell. Biol.* 18, 887-895, 1998.
35. Tahara, S., Tanaka, K., Yuasa, Y., and Okayama, H. Functional domains of Rep2, a transcriptional activator subunit for *Res2-Cdc10*, controlling the cell cycle start. *Mol. Biol. Cell* 9, 1577-1588, 1998.
36. Tsukahara, K., Yamamoto, H., and Okayama, H. An RNA binding protein negatively controlling differen-

- tiation in fission yeast. *Mol Cell. Biol.* 18, 4488-4498, 1998.
37. Jinno, S., Hung, S.-C., and Okayama, H. Cell cycle start from quiescence controlled by tyrosine phosphorylation of Cdk4. *Oncogene* 18, 565-577, 1999.
 38. Yamamoto, H., Tsukahara, K., Kanaoka, Y., Jinno, S., and Okayama, H. Isolation of a mammalian homologue of a fission yeast differentiation regulator. *Mol. Cell. Biol.* 19, 3829-3841, 1999.
 39. Jinno, S., Hung, S.-C., Yamamoto, Y., Lin, J., Nagata, A., and Okayama, H. Oncogenic stimulation recruits Cdk6 in the cell cycle start in rat fibroblast. *Proc. Natl. Acad. Sci. USA* 96, 13197-13202, 1999.
 40. Suto, K., Murakami, H., Nagata, A., and Okayama, H. A double-strand Break repair component is essential for S phase completion in fission yeast cell cycling. *Mol. Biol. Cell* 10, 3331-3343, 1999.
 41. Masuda, M., Nagai, Y., Oshima, N., Tanaka, K., Murakami, H., Igarashi, H., and Okayama H. Genetic Studies with the Fission Yeast *Schizosaccharomyces pombe* Suggest Involvement of Wee1, Ppa2, and Rad24 in Induction of Cell Cycle Arrest by Human Immunodeficiency Virus Type 1 Vpr. *J. Virol.* 74, 2636-2646, 2000.
 42. Tanaka, K., Yonekawa, T., Kawasaki, Y., Kai, M., Furuya, K., Iwasaki, M., Murakami, H., Yanagida, M., and Okayama, H. Fission yeast Eso1p is required for establishing chromatid cohesion during S phase. *Mol. Cell. Biol.* 20, 3459-3469, 2000.
 43. Yamaguchi, S., Okayama, H. and Nurse, P. Fission yeast Fizzy-related protein *Srw1p* is a G(1)-specific promoter of mitotic cyclin B degradation. *EMBO J.* 19, 3968-3977, 2000.
 44. Tanaka, K., and Okayama, H. A Pcl-like cyclin activates the *Res2p-Cdc10p* cell cycle 'start' transcriptional factor in fission yeast. *Mol. Biol. Cell* 11, 2845-2862, 2000.
 45. Nakamura, E., Isobe, H., Tomita, N., Sawamura, M., Jinno, S., and Okayama, H. Functionalized fullerene as an artificial vector for transfection. *Angew. Chem.* 112, 4424-4427, 2000.
 46. Jinno, S., Lin, J., Yageta, M., and Okayama, H. Oncogenic cell cycle start control. *Mut. Res.* 477, 23-29, 2001.
 47. Lin, J., Jinno, S., and Okayama H. Cyclin D3-Cdk6 complex evades inhibition by inhibitor proteins and uniquely controls cell's growth competence. *Oncogene* 20, 2000-2009, 2001.
 48. Tanaka, K., Hao, Z., Kai, M. and Okayama, H. Establishment and maintenance of sister chromatid cohesion in fission yeast by a unique mechanism. *EMBO J.* 20, 5779-5790, 2001.
 49. Jinno, S., Yageta, M., Nagata, A. and Okayama, H. *Cdc6* requires anchorage for its expression. *Oncogene* 21, 1777-1784, 2002.
 50. Hiroi, N., Jinno, S., and Okayama, H. Mammalian *Rcd1* is a novel transcriptional cofactor that mediates retinoic acid-induced cell differentiation. *EMBO J.* 21, 5235-5244, 2002.

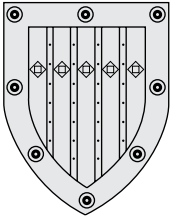

Department of Cellular Signaling

Outline and Research Objectives

When cells are stimulated, by the serial actions of various enzymes, biologically active lipid molecules are produced and released. They include prostaglandins, leukotrienes, platelet-activating factor (PAF), lysophosphatidic acid (LPA) etc., collectively termed lipid mediators (Fig 1). In concert with various neurotransmitters and hormones, these lipid mediators are playing important roles in self-defenses and maintenance of homeostasis. Unlike the biogenic amines or peptide mediators, lipid mediators are not stored in granules, but they are biosynthesized from precursor lipids when necessary. To elucidate the functions of lipid mediators, we isolated enzymes involved in the biosyntheses and metabolism of lipid mediators, isolated G-protein-coupled receptors, and identification of intracellular signaling. We are especially interested in identifying the specific roles of lipid mediators in inflammatory responses as well as neuronal functions. We generated several transgenic or knockout mice and analysed their roles in vivo. By mass spectrometric analyses, we also measured dynamic changes in membrane lipid compositions, the significance of these changes being in general signaling pathway. In the postsequence of whole human genome, the intensive studies of protein regulation as well as behavior of small lipid metabolites are of the highest importance.

Faculties and Students

Professor	Takao Shimizu, M.D., Ph.D. (1991-)
Associate Professor	Takehiko Yokomizo, M.D., Ph.D.
Associate3
Postdoctoral Fellows4
Graduate Students12
Research Students7
Secretary2

enzymes involved in the biosyntheses and metabolism of lipid mediators. Leukotriene A4 hydrolase, one of the key enzyme in the biosynthesis of chemotactic leukotrienes, was cloned and characterized in our laboratory. This achievement was the first successful example of molecular cloning of the enzymes in the field of lipid mediators. We also obtained PAF receptor, as the first successful example of receptor cloning of lipid mediators, followed by cloning receptors of various lipid mediators. We determined the regulation of these enzymes by Ca-dependent intracellular translocation, phosphorylation by various kinases, and other posttranslational modifications. We also

Past Research and Major Accomplishments

We have purified and cDNA cloned various

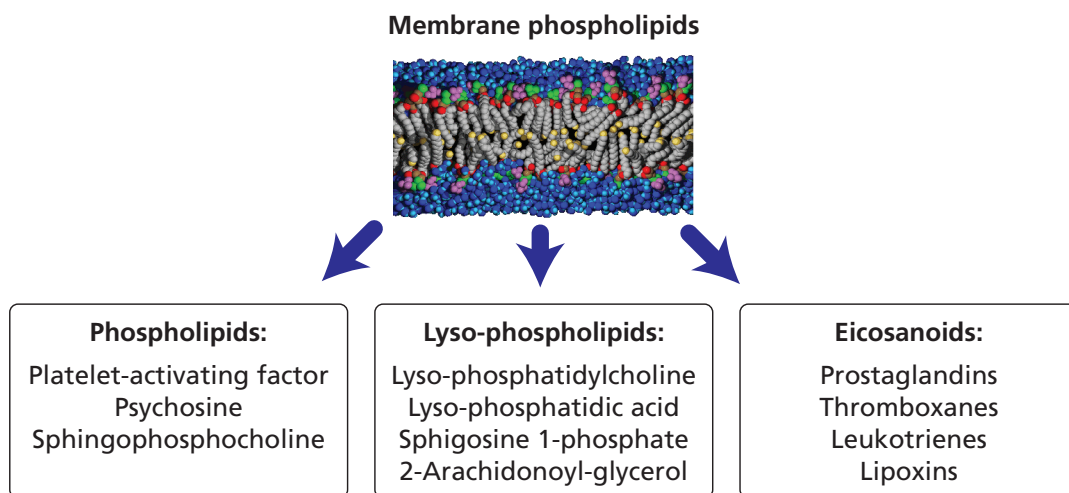

generated PAF receptor-overexpressing mice, PAF receptor-deficient mice, leukotriene receptor-deficient mice, and the mice deficient in cytosolic phospholipase A2 (cPLA2), which are involved in the syntheses of eicosanoids and PAF. By analyzing the phenotypes of these mice, we reported that the mediators are involved in the pathogenesis of various inflammatory and immune disorders, as well as normal physiology including reproduction and synaptic plasticity. Independently, one of the Associate is working on axon guidance molecules, by establishing knockout mice of guidance molecules (Sema 3A), and analyses of their multiple phenotypes.

Current Research

Followings are ongoing projects in our laboratory.

1. Elucidation of enzymes in the biosyntheses of lipid mediators, their regulation and mechanism of intracellular translocation by stimuli.
2. Deorphaning projects of putative lipid mediator GPCRs, which include indentificaion of novel lipid mediators (Fig. 2).
3. Elucidation of GPCR-sorting mechanism in polarized cells (kidney epithelial cells, neuron etc.)
4. Phenotype analyses of various genetic engineered mice. Understanding of the molecular mechanism of individual phenotypes in depth.

Phylogenetic Tree of various GPCRs

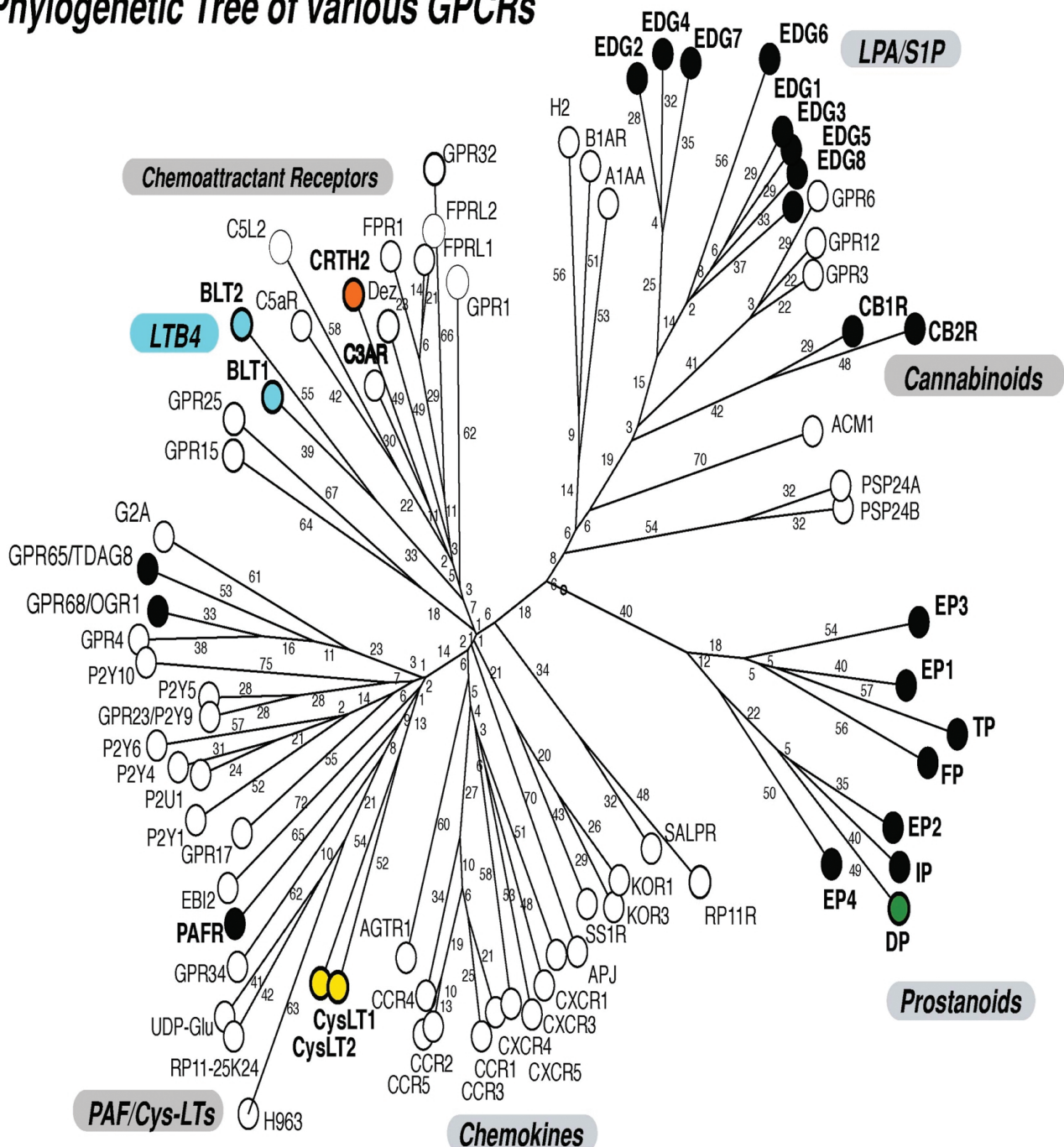

5. Establishment of novel gene-targeted mice (enzymes and receptors), and their congenic line (B6, Balb/c, DBA etc.)
6. Identification of Sema3A knockout mice, in nervous systems, olfactory systems, bone formation.

Future Prospects

We will pursue following different projects, lead by each faculty member.

1. Identification of the roles of lipid mediators in the central nervous system. For this purpose, we will analyze the localization and subcellular localization of enzymes involved in the biosyntheses of lipid mediators. It is the most important to determine, how and which direction (either axon or dendrite), these enzyme cause translocation in a stimulus-dependent manner. The mice deficient of enzymes or receptors of lipid mediators are useful to identify the roles of mediators in the central nervous systems. Some link has been reported between Sema3A axon guidance molecules and lipid mediators. By the use of double knockout mice (Sema3A and lipid mediators), more confirmative and direct evidence will be obtained.
2. We have so far obtained various phenotypes of genetic engineered mice, but molecular mechanisms underlying these phenotypes remain mostly unknown. The link between lipid mediators and hormones, neurotransmitters, and cytokines will be analyzed to obtain a whole view.
3. By mass spectrometric analyses, we like to find out the temporal and positional dynamic changes of membrane compositions including Raft and caveolae. Also, mass spectrometry attached with HPLC will aid in the identification of novel natural lipid mediators (deorphaning project). For these purposes, we recently built a new research group called Department of Lipid Metabolome, by donation. We have collected several excellent lipid biochemists, and mass spectrometer specialists. Metabolome (metabolomics) is a new research strategy after genome and proteome research. The study is to analyze in detail small-sized molecules (metabolites), and in combination with proteomics, we will gain a more broad view how cells adapt to a new environment, change membrane fluidity, and cause metabolic changes, which finally yield to gene expression.

Research Grants

1. 1998-2003 CREST of Japan Science and Technology Corporation
2. 2001-2004 PREST of Japan Science and Technology Corporation

3. 1999-2002 Grant from the Ministry of Education, Science, Culture, Sports, and Technology of Japan (A, B, and C)
4. 1997 Priority Area A, from the Ministry of Education, Science, Culture, Sports, and Technology of Japan.
5. 1996-2000 Ministry of Welfare, Health and Labor.

Select Publications (50 among 128 publications between 1991 and 2002)

1. Ito, N., Yokomizo, T., Sasaki, T., Kurosu, H., Penninger, J., Kanaho, Y., Katada, T., Hanaoka, K., and Shimizu, T. Requirement of phosphatidylinositol 3-kinase-activation and Ca influx for leukotriene B₄-induced enzyme release. *J. Biol. Chem.* in press, 2002.
2. Stromgaard, K., Saito, D.R., Shindou, H., Ishii, S., Shimizu, T., and Nakanishi, K. Ginkgolide derivatives for photolabeling studies: preparation and pharmacological evaluation. *J. Med. Chem.* 45,4038-46, 2002.
3. Wong, D.A., Uozumi, N., Kita, Y., and Shimizu, T. Discrete role for cytosolic phospholipase A₂-alpha in platelets: Studies using single and double mutant mice of cytosolic and group IIA-secretory phospholipase A₂. *J. Exp. Med.* 196,349-57, 2002.
4. Ogasawara, H., Ishii, S., Yokomizo, T., Kakinuma, T., Komine, M., Tamaki, K., Shimizu, T., and Izumi, T. Characterization of mouse cysteinyl leukotriene receptors, mCysLT1 and mCysLT2: Differential pharmacological properties and tissue distribution. *J. Biol. Chem.* 277, 18763-18768, 2002.
5. Nagase, T., Uozumi, N., Ishii, S., Kita, Y., Yamamoto, H., Ohga, E., Ouchi, Y. and Shimizu, T. A pivotal role of cytosolic phospholipase A₂ in bleomycin-induced pulmonary fibrosis. *Nature Med.* 8, 480-484, 2002.
6. Ohshima, N., Ishii, S., Izumi, T., and Shimizu, T. Receptor-dependent metabolism of platelet-activating factor in murine macrophages. *J. Biol. Chem.* 277, 9722-9727, 2002.
7. Nagase, T., Ishii, S., Shindou, H., Ouchi, Y., and Shimizu, T. Airway hyperresponsiveness in transgenic mice overexpressing platelet activating factor receptor is mediated by an atropine-sensitive pathway. *Am. J. Respir. Crit. Care Med.* 165, 200-205, 2002.
8. Yokomizo, T., Izumi, T., and Shimizu, T. Leukotriene B₄: metabolism and signal transduction. *Arch. Biochem. Biophys.* 385, 231-241, 2001.
9. Yokomizo, T., Kato, K., Hagiya, H., Izumi, T., and Shimizu, T. Hydroxyeicosanoids bind to and activate the low affinity leukotriene B₄ receptor, BLT₂. *J. Biol. Chem.* 276, 12454-12459, 2001.
10. Wu, C., Stojanov, T., Chami, O., Ishii, S., Shimizu, T., Li, A., and O'Neill, C. Evidence for the autocrine induction of capacitation of mammalian spermatozoa. *J. Biol. Chem.* 276, 26962-26968, 2001.
11. Yamashita, A., Kawagishi, N., Miyashita, T., Nagatsuka, T., Sugiura, T., Kume, K., Shimizu, T.,

- and Waku, K. ATP-independent fatty acyl-coenzyme A synthesis from phospholipid: coenzyme A-dependent transacylation activity toward lysophosphatidic acid catalyzed by acyl-coenzyme A:lysophosphatidic acid acyltransferase. *J. Biol. Chem.* 276, 26745-26752, 2001.
12. Kim, Y. J., Noguchi, S., Hayashi, Y. K., Tsukahara, T., Shimizu, T., and Arahata, K. The product of an oculopharyngeal muscular dystrophy gene, poly(A)-binding protein 2, interacts with SKIP and stimulates muscle-specific gene expression. *Hum. Mol. Genet.* 10, 1129-1139, 2001.
 13. Fukunaga, K., Ishii, S., Asano, K., Yokomizo, T., Shiomi, T., Shimizu, T., and Yamaguchi, K. Single nucleotide polymorphism of human platelet-activating factor receptor impairs G-protein activation. *J. Biol. Chem.* 276, 43025-43030, 2001.
 14. Aihara, M., Ishii, S., Kume, K., and Shimizu, T. Interaction between neurone and microglia mediated by platelet-activating factor. *Genes Cells* 5, 397-406, 2000.
 15. Noiri, E., Yokomizo, T., Nakao, A., Izumi, T., Fujita, T., Kimura, S., and Shimizu, T. An in vivo approach showing the chemotactic activity of leukotriene B(4) in acute renal ischemic-reperfusion injury. *Proc. Natl. Acad. Sci. USA* 97, 823-828, 2000.
 16. Nagase, T., Uozumi, N., Ishii, S., Kume, K., Izumi, T., Ouchi, Y., and Shimizu, T. Acute lung injury by sepsis and acid aspiration: a key role for cytosolic phospholipase A2. *Nat. Immunol.* 1, 42-46, 2000.
 17. Kato, K., Yokomizo, T., Izumi, T., and Shimizu, T. Cell-specific transcriptional regulation of human leukotriene B(4) receptor gene. *J. Exp. Med.* 192, 413-420, 2000.
 18. Yokomizo, T., Kato, K., Terawaki, K., Izumi, T., and Shimizu, T. A second leukotriene B(4) receptor, BLT2. A new therapeutic target in inflammation and immunological disorders. *J. Exp. Med.* 192, 421-432, 2000.
 19. Takaku, K., Sonoshita, M., Sasaki, N., Uozumi, N., Doi, Y., Shimizu, T., and Taketo, M. M. Suppression of intestinal polyposis in Apc(delta 716) knockout mice by an additional mutation in the cytosolic phospholipase A(2) gene. *J. Biol. Chem.* 275, 34013-34016, 2000.
 20. Nakatani, N., Uozumi, N., Kume, K., Murakami, M., Kudo, I., and Shimizu, T. Role of cytosolic phospholipase A2 in the production of lipid mediators and histamine release in mouse bone-marrow-derived mast cells. *Biochem. J.* 352 Pt 2, 311-317, 2000.
 21. Okamoto, H., Takuwa, N., Yokomizo, T., Sugimoto, N., Sakurada, S., Shigematsu, H., and Takuwa, Y. Inhibitory regulation of Rac activation, membrane ruffling, and cell migration by the G protein-coupled sphingosine-1-phosphate receptor EDG5 but not EDG1 or EDG3. *Mol. Cell Biol.* 20, 9247-9261, 2000.
 22. Kobayashi, K., Ishii, S., Kume, K., Takahashi, T., Shimizu, T., and Manabe, T. Platelet-activating factor receptor is not required for long-term potentiation in the hippocampal CA1 region. *Eur. J. Neurosci.* 11, 1313-1316, 1999.
 23. Nagase, T., Ishii, S., Kume, K., Uozumi, N., Izumi, T., Ouchi, Y., and Shimizu, T. Platelet-activating factor mediates acid-induced lung injury in genetically engineered mice. *J. Clin. Invest.* 104, 1071-1076, 1999.
 24. Hirabayashi, T., Kume, K., Hirose, K., Yokomizo, T., Iino, M., Itoh, H., and Shimizu, T. Critical duration of intracellular Ca²⁺ response required for continuous translocation and activation of cytosolic phospholipase A2. *J. Biol. Chem.* 274, 5163-5169, 1999.
 25. Ishii, I., Saito, E., Izumi, T., Ui, M., and Shimizu, T. Agonist-induced sequestration, recycling, and resensitization of platelet-activating factor receptor. Role of cytoplasmic tail phosphorylation in each process. *J. Biol. Chem.* 273, 9878-9885, 1998.
 26. Hoshino, M., Izumi, T., and Shimizu, T. Leukotriene D4 activates mitogen-activated protein kinase through a protein kinase C α -Raf-1-dependent pathway in human monocytic leukemia THP-1 cells. *J. Biol. Chem.* 273, 4878-4882, 1998.
 27. Ishii, S., Kuwaki, T., Nagase, T., Maki, K., Tashiro, F., Sunaga, S., Cao, W. H., Kume, K., Fukuchi, Y., Ikuta, K., Miyazaki, J., Kumada, M., and Shimizu, T. Impaired anaphylactic responses with intact sensitivity to endotoxin in mice lacking a platelet-activating factor receptor. *J. Exp. Med.* 187, 1779-1788, 1998.
 28. Hirohashi, T., Suzuki, H., Ito, K., Ogawa, K., Kume, K., Shimizu, T., and Sugiyama, Y. Hepatic expression of multidrug resistance-associated protein-like proteins maintained in eisai hyperbilirubinemic rats. *Mol. Pharmacol.* 53, 1068-1075, 1998.
 29. Ishii, S., Nagase, T., Tashiro, F., Ikuta, K., Sato, S., Waga, I., Kume, K., Miyazaki, J., and Shimizu, T. Bronchial hyperreactivity, increased endotoxin lethality and melanocytic tumorigenesis in transgenic mice overexpressing platelet-activating factor receptor. *EMBO J.* 16, 133-142, 1997.
 30. Kume, K., and Shimizu, T. Platelet-activating factor (PAF) induces growth stimulation, inhibition, and suppression of oncogenic transformation in NRK cells overexpressing the PAF receptor. *J. Biol. Chem.* 272, 22898-22904, 1997.
 31. Ishii, I., Izumi, T., Tsukamoto, H., Umeyama, H., Ui, M., and Shimizu, T. Alanine exchanges of polar amino acids in the transmembrane domains of a platelet-activating factor receptor generate both constitutively active and inactive mutants. *J. Biol. Chem.* 272, 7846-7854, 1997.
 32. Honda, Z., Suzuki, T., Hirose, N., Aihara, M., Shimizu, T., Nada, S., Okada, M., Ra, C., Morita, Y., and Ito, K. Roles of C-terminal Src kinase in the initiation and the termination of the high affinity IgE receptor-mediated signaling. *J. Biol. Chem.* 272, 25753-25760, 1997.
 33. Yokomizo, T., Izumi, T., Chang, K., Takuwa, Y., and Shimizu, T. A G-protein-coupled receptor for leukotriene B4 that mediates chemotaxis. *Nature* 387, 620-624, 1997.

34. Uozumi, N., Kume, K., Nagase, T., Nakatani, N., Ishii, S., Tashiro, F., Komagata, Y., Maki, K., Ikuta, K., Ouchi, Y., Miyazaki, J., and Shimizu, T. Role of cytosolic phospholipase A2 in allergic response and parturition. *Nature* 390, 618-622, 1997.
35. Yokomizo, T., Ogawa, Y., Uozumi, N., Kume, K., Izumi, T., and Shimizu, T. cDNA cloning, expression, and mutagenesis study of leukotriene B4 12-hydroxydehydrogenase. *J. Biol. Chem.* 271, 2844-2850, 1996.
36. Ferby, I. M., Waga, I., Hoshino, M., Kume, K., and Shimizu, T. Wortmannin inhibits mitogen-activated protein kinase activation by platelet-activating factor through a mechanism independent of p85/p110-type phosphatidylinositol 3-kinase. *J. Biol. Chem.* 271, 11684-11688, 1996.
37. Kishimoto, S., Shimadzu, W., Izumi, T., Shimizu, T., Fukuda, T., Makino, S., Sugiura, T., and Waku, K. Regulation by IL-5 of expression of functional platelet-activating factor receptors on human eosinophils. *J. Immunol.* 157, 4126-4132, 1996.
38. Mori, M., Aihara, M., Kume, K., Hamanoue, M., Kohsaka, S., and Shimizu, T. Predominant expression of platelet-activating factor receptor in the rat brain microglia. *J. Neurosci.* 16, 3590-3600, 1996.
39. Mutoh, H., Fukuda, T., Kitamaoto, T., Masushige, S., Sasaki, H., Shimizu, T., and Kato, S. Tissue-specific response of the human platelet-activating factor receptor gene to retinoic acid and thyroid hormone by alternative promoter usage. *Proc. Natl. Acad. Sci. USA* 93, 774-779, 1996.
40. Watanabe, T., Waga, I., Honda, Z., Kurokawa, K., and Shimizu, T. Prostaglandin F2 alpha stimulates formation of p21ras-GTP complex and mitogen-activated protein kinase in NIH-3T3 cells via Gq-protein-coupled pathway. *J. Biol. Chem.* 270, 8984-8990, 1995.
41. Honda, Z., Takano, T., Hirose, N., Suzuki, T., Muto, A., Kume, S., Mikoshiba, K., Itoh, K., and Shimizu, T. Gq pathway desensitizes chemotactic receptor-induced calcium signaling via inositol trisphosphate receptor down-regulation. *J. Biol. Chem.* 270, 4840-4844, 1995.
42. Shirasaki, H., Nishikawa, M., Adcock, I. M., Mak, J. C., Sakamoto, T., Shimizu, T., and Barnes, P. J. Expression of platelet-activating factor receptor mRNA in human and guinea pig lung. *Am. J. Respir. Cell Mol. Biol.* 10, 533-537, 1994.
43. Takano, T., Honda, Z., Sakanaka, C., Izumi, T., Kameyama, K., Haga, K., Haga, T., Kurokawa, K., and Shimizu, T. Role of cytoplasmic tail phosphorylation sites of platelet-activating factor receptor in agonist-induced desensitization. *J. Biol. Chem.* 269, 22453-22458, 1994.
44. Honda, Z., Takano, T., Gotoh, Y., Nishida, E., Ito, K., and Shimizu, T. Transfected platelet-activating factor receptor activates mitogen-activated protein (MAP) kinase and MAP kinase kinase in Chinese hamster ovary cells. *J. Biol. Chem.* 269, 2307-2315, 1994.
45. Ferby, I. M., Waga, I., Sakanaka, C., Kume, K., and Shimizu, T. Wortmannin inhibits mitogen-activated protein kinase activation induced by platelet-activating factor in guinea pig neutrophils. *J. Biol. Chem.* 269, 30485-30488, 1994.
46. Bito, H., Mori, M., Sakanaka, C., Takano, T., Honda, Z., Gotoh, Y., Nishida, E., and Shimizu, T. Functional coupling of SSTR4, a major hippocampal somatostatin receptor, to adenylate cyclase inhibition, arachidonate release and activation of the mitogen-activated protein kinase cascade. *J. Biol. Chem.* 269, 12722-12730, 1994.
47. Bito, H., Nakamura, M., Honda, Z., Izumi, T., Iwatsubo, T., Seyama, Y., Ogura, A., Kudo, Y., and Shimizu, T. Platelet-activating factor (PAF) receptor in rat brain: PAF mobilizes intracellular Ca²⁺ in hippocampal neurons. *Neuron* 9, 285-294, 1992.
48. Nakamura, M., Honda, Z., Izumi, T., Sakanaka, C., Mutoh, H., Minami, M., Bito, H., Seyama, Y., Matsumoto, T., Noma, M., and Shimizu, T. Molecular cloning and expression of platelet-activating factor receptor from human leukocytes. *J. Biol. Chem.* 266, 20400-20405, 1991.
49. Honda, Z., Nakamura, M., Miki, I., Minami, M., Watanabe, T., Seyama, Y., Okado, H., Toh, H., Ito, K., Miyamoto, T., and Shimizu, T. Cloning by functional expression of platelet-activating factor receptor from guinea-pig lung. *Nature* 349, 342-346, 1991.
50. Watanabe, T., Yatomi, Y., Sunaga, S., Miki, I., Ishii, A., Nakao, A., Higashihara, M., Seyama, Y., Ogura, M., Saito, H., Kurokawa, K., and Shimizu, T. Characterization of prostaglandin and thromboxane receptors expressed on a megakaryoblastic leukemia cell line, MEG-01s. *Blood* 78, 2328-2336, 1991.

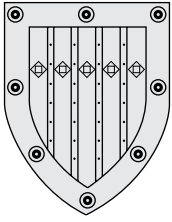

Department of Physiological Chemistry and Metabolism

Outline and Research Objectives

The Department of Physiological Chemistry and Nutrition, the predecessor of the present department, was founded in 1952. The successive professors were as follows;

The first professor: Haruhisa Yoshikawa (1952~1969)

The second professor: Osamu Hayaishi (1970~1974)

The third professor: Yoshitake Mano (1974~1982)

The fourth professor: Yousuke Seyama (1983~2001)

During the past 50 years, these professors lead high-quality researches in the field of biochemistry, metabolism and nutrition and greatly contributed to scientific progresses in Japan. Upon the restructuring of the university system in 1997, the department was renamed 'Department of Physiological Chemistry and Metabolism' as one unit of the Specialty of Molecular Cell Biology. In 2002, Dr. Hiroki Kurihara was designated as a successor of Professor Yousuke Seyama, and started new researches on developmental biology and technology as well as regenerative medicine.

Faculties and Students

Professor and Chair Hiroki Kurihara, M.D., Ph.D. (2002~)

Associate3

Postdoctoral Fellow1

Graduate Student.....2

Secretary1

Past Research and Major Accomplishments

1. Vascular Biology

(1) Biology of Vasoactive Peptides

i) Endothelin

a. Discovery and Basic Characterization of Endothelin

Our researches started with contribution to the discovery of endothelin (ET-1), an endothelium-derived vasoactive peptide, with Drs. Masashi Yanagisawa, Tomoh Masaki and colleagues in 1987. Then, we studied the role of ET-1 in vascular physiology and pathophysiology and revealed its vasoconstrictive effect on *in vivo* canine coronary arteries and induction of the ET-1 gene by some cytokines and flow-induced mechanical stress in vascular endothelial cells.

b. Endothelin-1 Knockout Mice

In 1991, we introduced the technique of gene targeting in mice to our lab to further analyze the biological implication of ET-1. As a result, we found two novel and important roles of ET-1. First, ET-1 proved to lower blood pressure when it acts

in the central nervous system although it mainly acts as a pressor in the periphery. ET-1 also modulates stress responses in the central nervous system by regulating catecholamine metabolism. Second, ET-1 proved to be essential for embryogenesis. The phenotype of mice lacking ET-1 involved craniofacial and cardiac neural crest-derived structures including the branchial arches and great vessels. Indeed, ET-1 was the first vasoactive substance bound to G protein-coupled receptors that proved to be involved in embryonic development (See 2-1)).

c. Endothelin-1 Overexpressing Mice

We found that the expression of ET-1 and its processing enzyme ECE-1 is increased in the lesion of human atherosclerosis and experimental vascular injury. The effect of overexpressed ET-1 was further analyzed in transgenic mice and proved to cause mesangial hyperplasia and glomerulosclerosis in the kidney. This result was indicative of the stimulating effect of ET-1 on cellular proliferation and remodeling *in vivo*.

ii) Adrenomedullin

a. Adrenomedullin Overexpressing Mice

Adrenomedullin (AM), a vasodilating peptide, can be regarded as a counterpart of ET-1 in vascular tone regulation. We investigated the *in vivo* effect of AM by producing transgenic mice overexpressing AM and found NO-dependent hypotension and resistance to endotoxin shock (decrease in lethality) in transgenic mice. These results suggested that AM may lower blood pressure by stim-

ulating NO production and that AM may protect tissues and organs from shock-induced damage.

b. Adrenomedullin Knockout Mice

The biological importance of AM was further investigated by gene targeting. We demonstrated that AM is indispensable for the vascular morphogenesis during embryonic development and for postnatal regulation of blood pressure by stimulating NO production, confirming the hypothesis derived from AM overexpression mice.

iii) CGRP

CGRP is structural related to AM and shares the common receptor CRLR. To investigate systematically the differential role of the AM/CGRP family members, we established alphaCGRP knockout mice. The resultant phenotype revealed that alphaCGRP contributes to the regulation of cardiovascular function through inhibitory modulation of sympathetic nervous activity and that AM and CGRP have distinct physiological roles.

(2) Transgenic techniques

During gene manipulation studies in mice, we found that the ET-1 gene promoter is useful for vessel-selective gene expression. This promoter was used not only to overexpress ET-1 and AM but also to make endothelial NO synthase and 15-lipoxygenase overexpressing mice by our collaborators with fruitful results. Recently, we realized targeting gene expression in vascular smooth muscle cells by using the ET-A receptor (ETAR) gene promoter.

2. Developmental Biology

(1) Neural Crest Development

Craniofacial and cardiovascular defects in ET-1 knockout embryos gave a clue to the elucidation of mechanisms for branchial arch formation contributed by neural crest cells. By subsequent analysis, we revealed that ET-1 regulates several downstream genes such as HAND1/2 and Gooseoid transcription factors to contribute to cranial/cardiac neural crest development. Recently, we established ETAR promoter::GFP and ETAR promoter::TVA (avian retrovirus receptor) to visualize and isolate ETAR+ neural crest cells and to transfer genes specifically to them via retroviral vectors. These systems serve as very useful tools for the analysis of neural crest-derived branchial arch development.

(2) Vascular Development

ET-1 knockout mice also demonstrated defects in the great vessels and cardiac outflow tract, to which cardiac neural crest cells largely contribute. From this result, we found that ET-1 is important in vascular smooth muscle cell development originated from neu-

ral crest cells and that the ET-1 to HAND2 signaling pathway seems to be critical. The outcome from AM knockout mice showed that AM is important in the formation of basement membrane during angiogenesis to stabilize vascular network.

3. Collaborative Works

(1) Biology of Metalloproteinase

In collaboration with Dr. Kouji Matsushima (Dept. of Molecular Preventive Medicine), we exploited the biological implication of ADAMTS-1, a member of the ADAM-type metalloproteinase family, by gene targeting. We found that ADAMTS-1 is important for normal growth, fertility and organ development (the kidneys, adrenal glands, adipose tissues etc.).

(2) Biology of Antimicrobial Peptides

In collaboration with Drs. Yasuyoshi Ouchi and Takahide Nagase (Dept. of Geriatrics), we are studying about defensins, endogenous antimicrobial peptides. We have identified several novel types of human and mouse beta-defensins which are expressed skeletal muscle and epididymis.

Current Research

1. Vascular Biology

We have converged our previous achievement of vascular biology on the aspect of developmental biology including vascular development as described below.

2. Developmental Biology

(1) Neural Crest Development

Extending our achievement of ET-1 knockout mice, we are studying the mechanism how the intercellular and intracellular signaling system related ET-1 is involved in neural crest development and branchial arch formation because it may give a clue to the insight how signaling interactions can change cellular behavior to lead to morphogenesis. For this purpose, we have established GFP and TVA transgenic mice as described and are now establishing some other mice which will be useful for the analysis of branchial arch formation. We are also performing a systematic screening for differential gene expression by DNA microarray followed by in situ hybridization. By this method, several important genes are to be obtained.

We are also studying about neural crest differentiation using murine neural crest cell culture and Sendai virus vectors developed by Drs. Yoshiyuki Nagai and Atsushi Kato. In our preliminary result, we realized nearly 100 % gene transfer into neural crest cells and are analyzing the effect of some genes on neural crest

differentiation. Using some markers, we are also trying to isolate neural crest stem cells.

We are further looking for the mechanism how some transcription factors important for neural crest development can exert their effects. For this purpose, we are performing yeast two-hybrid screening using Pax3 and HAND2 as baits. We have obtained several interesting clones and are analyzing their molecular characteristics.

(2) Vascular Development

Above-mentioned studies concerning neural crest differentiation include the issue of vascular smooth muscle cell differentiation and we are trying to identify the target genes of the ET-1-HAND2 pathway that is important for smooth muscle differentiation. Two-hybrid studies also involve this theme. Abnormalities in vascular formation in AM knockout mice are also being investigated further concerning the mechanism.

In addition, we have started studies on vascular endothelial cell differentiation using the embryonic stem cell system and are looking for possible interaction between neural crest-derived smooth muscle precursors and endothelial precursors. It may clarify a novel cellular interaction mechanism which can stimulate vascular formation.

3. Collaborative Works

In collaboration with Drs. Yasuyoshi Ouchi and Takahide Nagase (Dept. of Geriatrics), we are starting further study on defensins using gene manipulation in mice.

Future Prospects

(1) Basic research

Our future study will focus mainly on neural crest and vascular development. Especially, major questions are (1) how do intracellular mechanisms modulate stem cell behavior including fate determination and differentiation, and (2) how are cell behaviors integrated into morphogenesis and organogenesis. By studying neural crest development as a model, we expect that we can approach these general issues. For our coming research, we are introducing some new techniques such as nuclear transfer.

(2) Applied research

Our current researches on vascular development using embryonic stem cells are close to applied researches in the field of regenerative medicine. On this background together with nuclear transfer technique, we are planning translational researches to generate vessels and other tissues and organs related

neural crest cells.

Research Grants

1. JSPS (Japan Society for the Promotion of Science) Research for the Future Program (2000.4~2004.3) total 240,000,000 yen.
2. Grants-in-Aid for Scientific Research from JSPS, Scientific Research (B) (2002.4~2004.3) total 14,900,000 yen
3. Grants-in-Aid for Scientific Research from JSPS, Exploratory Research (C) (2002.4~2004.3) total 9,900,000 yen
4. Grants-in-Aid for Scientific Research from the Ministry of Education, Science and Culture, Japan, Priority Areas Research (A), Allotted. (2000.4~2001.3) total 1,800,000 yen.
5. the Research Grant for Cardiovascular Diseases (14C-1) from the Ministry of Health and Welfare (2002.4~2005.3) total 6,300,000 yen.

Select Publications

1. Yanagisawa M, Kurihara H, Kimura S, Tomobe Y, Kobayashi M, Mitsui Y, Yazaki Y, Goto K, Masaki T. A novel vasoconstrictor peptide produced by vascular endothelial cells. *Nature* 332: 411-415, 1988.
2. Komuro I, Kurihara H, Sugiyama T, Yoshizumi M, Takaku F, Yazaki Y. Endothelin stimulates c-fos and c-myc expression and proliferation of vascular smooth muscle cells. *FEBS Lett.* 238: 249-252, 1988.
3. Kurihara H, Yoshizumi M, Sugiyama T, Takaku F, Yanagisawa M, Masaki T, Hamaoki M, Kato H, Yazaki Y. Transforming growth factor- β stimulates the expression of endothelin mRNA by vascular endothelial cells. *Biochem. Biophys. Res. Commun.* 359: 1435-1440, 1989.
4. Kurihara H, Yoshizumi M, Sugiyama T, Yamaoki K, Nagai R, Takaku F, Satoh H, Inui J, Yanagisawa M, Masaki T, Yazaki Y. The possible role of endothelin-1 in the pathogenesis of coronary vasospasm. *J. Cardiovasc. Pharmacol.* 13(Suppl. 5): S132-S137, 1989.
5. Kurihara H, Yamaoki K, Nagai R, Yoshizumi M, Takaku F, Satoh H, Inui J, Yazaki Y. Endothelin: a potent vasoconstrictor associated with coronary vasospasm. *Life Sci.* 44: 1937-1943, 1989.
6. Goto K, Kasuya Y, Matsuki N, Takawa Y, Kurihara H, Ishikawa T, Kimura S, Yanagisawa M, Masaki T. Endothelin activates the dihydropyridine-sensitive, voltage-dependent Ca²⁺-channel in vascular smooth muscle. *Proc. Natl. Acad. Sci. U.S.A.* 86: 3915-3918, 1989.
7. Ouchi Y, Kim S, Souza AC, Iijima S, Hattori A, Orimo H, Yoshizumi M, Kurihara H, Yazaki Y. Central effect of endothelin on blood pressure in conscious rats. *Am J. Physiol.* 256: H1747-H1751, 1989.
8. Yoshizumi M, Kurihara H, Sugiyama T, Takaku F, Yanagisawa M, Masaki T, Yazaki Y. Hemodynamic

- shear stress stimulates endothelin production by cultured endothelial cells. *Biochem. Biophys. Res Commun.* 161: 859-864, 1989.
9. Yoshizumi M, Kurihara H, Morita T, Yamashita T, Oh-hashii Y, Sugiyama T, Takaku F, Yanagisawa M, Masaki T, Yazaki Y. Interleukin-1 induces the production of endothelin-1 by cultured endothelial cells. *Biochem. Biophys. Res. Commun.* 166: 324-329, 1990.
 10. Morita T, Kurihara H, Yoshizumi M, Maemura K, Sugiyama T, Nagai R, Yazaki Y. Polymorphonuclear leukocytes have dual effects on endothelin-1: the induction of endothelin-1 mRNA expression in vascular endothelial cells and modification of the endothelin-1 molecule. *Heart Vessels* 8: 1-6, 1993.
 11. Morita T, Kurihara H, Maemura K, Yoshizumi M, Yazaki Y. Disruption of cytoskeletal structures mediates shear stress-induced endothelin-1 gene expression in cultured porcine aortic endothelial cells. *J. Clin. Invest.* 92: 1706-1712, 1993.
 12. Morita T, Yoshizumi M, Kurihara H, Maemura K, Nagai R, Yazaki Y. Shear stress increases heparin-binding epidermal growth factor-like growth factor mRNA levels in human vascular endothelial cells. *Biochem. Biophys. Res. Commun.* 197: 256-262, 1993.
 13. Kurihara Y*, Kurihara H*, Suzuki H, Kodama T, Maemura K, Nagai R, Oda H, Kuwaki T, Cao W-H, Kamada N, Jishage K, Ouchi Y, Azuma S, Toyoda Y, Ishikawa T, Kumada M, Yazaki Y. Elevated blood pressure and craniofacial abnormalities in mice deficient in endothelin-1. *Nature* 368: 703-710, 1994. (*equal contribution)
 14. Maemura K, Kurihara H, Kurihara Y, Nagai R, Yazaki Y. Isolation and characterization of vascular endothelial cells derived from mice lacking endothelin-1. *Biochem. Biophys. Res. Commun.* 201: 538-545, 1994.
 15. Maemura K, Kurihara Y, Morita H, Kurihara H, Yazaki Y. Renal endothelin and hypertension - reply. *Nature* 372: 50, 1994.
 16. Morita T, Kurihara H, Maemura K, Yoshizumi M, Nagai R, Yazaki Y. Role of Ca²⁺ and protein kinase C in shear stress-induced actin depolymerization and endothelin-1 gene expression. *Circ. Res.* 75: 630-636, 1994.
 17. Harats D*, Kurihara H*, Belloni P, Oakley H, Ziober A, Ackley D, Cain G, Kurihara Y, Lawn R, Sigal E. Targeting gene expression to the vascular wall in transgenic mice using the murine preproendothelin-1 promoter. *J. Clin. Invest.* 95: 1335-1344, 1995. (*equal contribution)
 18. Kurihara Y, Kurihara H, Oda H, Maemura K, Nagai R, Ishikawa T, Yazaki Y. Aortic arch malformations and ventricular septal defect in mice deficient in endothelin-1. *J. Clin. Invest.* 96: 293-300, 1995.
 19. Maemura K, Kurihara H, Kurihara Y, Oda H, Ishikawa T, Copeland NG, Gilbert DJ, Jenkins NA, Yazaki Y. Sequence analysis, chromosomal location and developmental expression of the mouse preproendothelin-1 gene. *Genomics* 31: 177-184, 1996.
 20. Kuwaki T, Cao W-H, Kurihara Y, Kurihara H, Ling G-Y, Onodera M, Ju K-H, Yazaki Y, Kumada M. Impaired ventilatory responses to hypoxia and hypercapnia in mutant mice deficient in endothelin-1. *Am. J. Physiol.* 270: R1279-R1286, 1996.
 21. Reid K, Turnley AM, Maxwell GD, Kurihara Y, Kurihara H, Bartlett PF, Murphy M. Multiple roles for endothelin 3 in melanocyte development: Regulation of progenitor number and stimulation of differentiation. *Development* 122: 3911-3919, 1996.
 22. Minamino T, Kurihara H, Takahashi M, Shimada K, Maemura K, Oda H, Ishikawa T, Uchiyama T, Tanzawa K, Yazaki Y. Endothelin converting enzyme (ECE-1) expression in the rat vascular injury model and human coronary atherosclerosis. *Circulation* 95: 221-230, 1997.
 23. Suzuki H, Kurihara Y, Takeya M, Kamada N, Kataoka M, Jishage K, Ueda O, Sakaguchi H, Higashi T, Suzuki T, Takashima Y, Kawabe Y, Cynshi O, Wada Y, Honda M, Kurihara H, Aburatani H, Doi T, Matsumoto A, Azuma S, Noda T, Toyoda Y, Itakura H, Yazaki Y, Horiuchi S, Takahashi K, Kruijt JK, van Berkel TJC, Steinbrecher UP, Ishibashi S, Maeda N, Gordon S, Kodama T. A role for macrophage scavenger receptors in atherosclerosis and susceptibility to infection. *Nature* 386: 292-296, 1997.
 24. Kurihara H, Kurihara Y, Maemura K, Yazaki Y. The role of endothelin-1 in cardiovascular development. *Ann. NY. Acad. Sci.* 811: 168-177, 1997.
 25. Morita H, Taguchi J, Kurihara H, Kitaoka M, Kaneda H, Kurihara Y, Maemura K, Shindo T, Minamino T, Ohno M, Yamaoki K, Ogasawara K, Aizawa T, Suzuki S, Yazaki Y. Genetic polymorphism of 5,10-methylenetetrahydrofolate reductase (MTHFR) as a risk factor for coronary artery disease. *Circulation* 95: 2032-2036, 1997.
 26. Kuwaki T, Kurihara H, Cao WH, Kurihara Y, Unekawa M, Yazaki Y, Kumada M: Physiological role of brain endothelin in the central autonomic control: from neuron to knockout mice. *Prog. Neurobiol.* 51: 545-579, 1997.
 27. Nagase T, Kurihara H, Kurihara Y, Aoki-Nagase T, Fukuchi Y, Yazaki Y, Ouchi Y. Airway hyperresponsiveness to methacholine in mutant mice deficient in endothelin-1. *Am. J. Respir. Crit. Care Med.* 157: 560-564, 1998.
 28. Kitano Y, Kurihara H, Kurihara Y, Maemura K, Ryo Y, Yazaki Y, Harii K. Gene expression of bone matrix proteins and endothelin receptors in endothelin-1-deficient mice revealed by in situ hybridization. *J. Bone Miner. Res.* 13: 237-244, 1998.
 29. Thomas T, Kurihara H, Yamagishi H, Kurihara Y, Yazaki Y, Olson EN, Srivastava D. A signaling cascade involving endothelin-1, dHAND and Msx1 regulates development of neural crest-derived branchial arch mesenchyme. *Development* 125: 3005-3014, 1998.
 30. Morita H, Kurihara H, Tsubaki S, Sugiyama T, Hamada C, Kurihara Y, Shindo T, Oh-hashii Y, Kitamura K, Yazaki Y. Methylenetetrahydrofolate

- reductase (MTHFR) gene polymorphism and ischemic stroke in Japanese. *Arterioscler. Thromb. Vasc. Biol.* 18: 1465-1469, 1998.
31. Ling GY, Cao WH, Onodera M, Ju KH, Kurihara H, Kurihara Y, Yazaki Y, Kumada M, Fukuda Y, Kuwaki T. Renal sympathetic nerve activity in mice: comparison between mice and rats and between normal and endothelin-1 deficient mice. *Brain Res.* 808: 238-249, 1998.
 32. Ohashi Y, Kawashima S, Hirata K, Yamashita T, Ishida T, Inoue N, Sakoda T, Kurihara H, Yazaki Y, Yokoyama M. Hypotension and reduced nitric oxide-elicited vasorelaxation in transgenic mice overexpressing endothelial nitric oxide synthase. *J. Clin. Invest.* 102: 2061-2071, 1998.
 33. Morita H, Kurihara H, Sugiyama T, Kurihara Y, Shindo T, Oh-hashii Y, Yazaki Y. D919G polymorphism of the methionine synthase gene. Association with homocysteine metabolism and late-onset vascular diseases in the Japanese population. *Arterioscler. Thromb. Vasc. Biol.* 19: 298-302, 1999.
 34. Kuwaki T, Ling GY, Onodera M, Ishii T, Nakamura A, Ju KH, Cao WH, Kumada M, Kurihara H, Kurihara Y, Yazaki Y, Ohuchi T, Yanagisawa M, Fukuda Y. Endothelin in the central control of cardiovascular and respiratory functions. *Clin. Exp. Pharmacol. Physiol.* 26: 989-994, 1999.
 35. Kurihara H, Kurihara Y, Nagai R, Yazaki Y. Endothelin and neural crest development. *Cell. Mol. Biol.* 45: 639-651, 1999.
 36. Nagase T, Kurihara H, Kurihara Y, Aoki-Nagase T, Nagai R, Ouchi Y. Disruption of ET-1 gene enhances pulmonary responses to methacholine via functional mechanism in knockout mice. *J. Appl. Physiol.* 87: 2020-2024, 1999.
 37. Shindo T, Kurihara H, Maemura K, Kurihara Y, Kuwaki T, Izumida T, Minamino N, Ju K-H, Morita H, Oh-hashii Y, Kumada M, Kangawa K, Nagai R, Yazaki Y. Hypotension and resistance to lipopolysaccharide-induced shock in transgenic mice overexpressing adrenomedullin in their vasculature. *Circulation* 101: 2309-2316, 2000.
 38. Kurihara Y*, Kurihara H*, Morita H, Cao W-H, Ling G-Y, Kumada M, Kimura S, Nagai R, Yazaki Y, Kuwaki T. Role of endothelin-1 in stress response in the central nervous system. *Am. J. Physiol.* 279: R515-R521, 2000. (*equal contribution)
 39. Shindo T, Kurihara H, Kuno K, Yokoyama H, Wada T, Kurihara Y, Imai T, Wang Y, Ogata M, Oh-hashii Y, Morita H, Ishikawa T, Nagai R, Yazaki Y, Matsushima K. ADAMTS-1: a metalloproteinase-disintegrin essential for normal growth, fertility and organ morphology and function. *J. Clin. Invest.* 105: 1345-1352, 2000.
 40. Harats D, Shaish A, George J, Mulkins M, Kurihara H, Levkovitz H, Sigal E. Overexpression of 15-lipoxygenase in vascular endothelium accelerates early atherosclerosis in LDL receptor-deficient mice. *Arterioscler. Thromb. Vasc. Biol.* 20: 2100-2105, 2000.
 41. Morita H, Kurihara H, Yoshida S, Saito Y, Shindo T, Oh-hashii Y, Kurihara Y, Yazaki Y, Nagai R. Diet-induced hyperhomocysteinemia exacerbates neointima formation in rat carotid arteries after balloon injury. *Circulation* 103: 133-139, 2001.
 42. Ho MCY, Lo ACY, Kurihara H, Yu ACH, Chung SK. Endothelin-1 protects astrocytes from hypoxic/ischemic injury. *FASEB J.* 15: 618-626, 2001.
 43. Imai T, Morita T, Shindo S, Nagai R, Yazaki Y, Kurihara H, Suematsu M, Katayama S. Vascular smooth muscle cell-directed overexpression of human heme oxygenase-1 elevates blood pressure through attenuation of NO-induced vasodilation in mice. *Circ. Res.* 89:55-62, 2001.
 44. Yamaguchi Y, Fukuhara S, Nagase T, Tomita T, Hitomi S, Kimura S, Kurihara H, Ouchi Y. A novel mouse β -defensin, mBD-6, predominantly expressed in skeletal muscle. *J. Biol.Chem.* 276:31510-31514, 2001.
 45. Imai Y, Shindo T, Maemura K, Kurihara Y, Nagai R, Kurihara H. Evidence for the physiological and pathological roles of adrenomedullin from genetic engineering in mice. *Ann. NY. Acad. Sci.* 947:26-34, 2001.
 46. Shindo T, Kurihara Y, Nishimatsu H, Moriyama N, Kakoki M, Wang Y, Imai Y, Ebihara A, Kuwaki T, Ju K-H, Minamino N, Kangawa K, Ishikawa T, Fukuda M, Akimoto Y, Kawakami H, Imai Y, Imai T, Morita H, Yazaki Y, Nagai R, Hirata Y, Kurihara H. Vascular abnormalities and elevated blood pressure in mice lacking adrenomedullin gene. *Circulation* 104:1964-1971, 2001.
 47. Oh-hashii Y, Shindo T, Kurihara Y, Imai T, Wang Y, Morita H, Imai Y, Kayaba Y, Nishimatsu H, Suematsu Y, Hirata Y, Yazaki Y, Nagai R, Kuwaki T, Kurihara H. Elevated sympathetic nervous activity in mice deficient in aCGRP. *Circ. Res.* 89:983-990, 2001.
 48. Shindo T, Kurihara H, Maemura K, Kurihara Y, Ueda O, Suzuki H, Kuwaki T, Ju K-H, Wang Y, Morita H, Oh-hashii Y, Kumada M, Nagai R, Yazaki Y, Kimura K. Renal damage and salt-dependent hypertension in aged transgenic mice overexpressing endothelin-1. *J. Mol. Med.* 80:105-116, 2002.
 49. Imai Y, Shindo T, Sata M, Memura K, Saito Y, Akishita M, Osuga J, Ishibashi S, Tobe K, Maekawa H, Oh-hashii Y, Morita H, Kurihara Y, Yazaki Y, Nagai R, Kurihara H. Resistance to neointimal hyperplasia and fatty streak formation in adrenomedullin overexpression mice. *Arterioscler. Thromb. Vasc. Biol.* 22: 1310-1315, 2002.
 50. Yamaguchi Y, Nagase T, Makita R, Fukuhara S, Tomita T, Tominaga T, Kurihara H, Ouchi Y. Identification of multiple novel epididymis-specific β -defensin isoforms in humans and mice. *J. Immunol.* 169: 2516-2523, 2002.

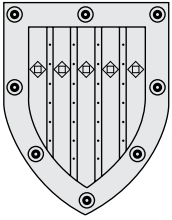

Department of Integrative Physiology

Outline and Research Objectives

This department was initially established in 1877 as the First Department of Physiology, and reorganized in 1997 as the Department of Integrative Physiology. Our department collaborates with other laboratories dedicated to Physiological Sciences, that is, the Department of Molecular/Cellular Physiology and the Department of Neurophysiology, in teaching activities for undergraduate courses and the nursing school. The fields in which our department specializes include the entire spectrum of the physiology of "animal functions", such as general physiology, sensory physiology, neurophysiology, higher nervous functions and cognitive neurosciences.

Faculties and Students

Professor and Chair	Yasushi Miyashita, Ph.D. (1989-)
Lecturer	Isao Hasegawa, M.D., Ph.D. (2000-)
Associate	2
Postdoctoral Fellow	5
Graduate Student.....	10
Research Student.....	1
Secretary	3

Past Research and Major Accomplishments

Most of our research has been focused on the higher brain functions of the mammalian central nervous system, in particular, the neural mechanisms of cognitive memory in the primate. The basic motivation of the research can be best explained as follows:

Knowledge or experiences are voluntarily recalled from memory by reactivation of their neural representations in the cerebral association cortex. Three questions are central in the understanding of this process:

- (1) Where are mnemonic representations coded and how are they organized?
- (2) Which neural processes create the representation?
- (3) What is the mechanism underlying reactivation of the representation on demand of voluntary recall?

1. Creating the mnemonic representation

Lesion studies in primates have implicated the IT cortex in long-term memory storage of visual objects [40]. Neuronal correlates of associative long-term memory were first discovered in the IT cortex by Miyashita [49, 50] and Sakai & Miyashita [45]. He developed a novel memory paradigm that requires the subject to create a link of associative memory between mathematically designed pictures (for examples, see Fig.1). Their single-unit recording experiments in the pair-association task identified two mnemonic properties of IT neurons. First, the stimu-

lus-selectivity of IT neurons can be acquired through learning in adulthood. Second, the activity of IT neurons can link the representations of temporally associated but geometrically unrelated stimuli.

2. Activating the representation in the temporal cortex on demand

In spite of the classical clinical observation that electric stimulation of the temporal lobe produces 'experiential responses', there have been no direct evidence supporting the notion of 'reactivation of neural representations' during memory retrieval. We first reported a neuronal correlate of the reactivation process as 'pair-recall neurons' [42, 45]. In our subsequent study [30], we devised a new modified pair-associate task in which the necessity for memory retrieval and its initiation time were controlled by a colour switch, independent of the cue stimulus presentation. Single-unit recordings in monkeys performing this task revealed that IT neurons selective to a memorized object are dynamically activated at the time of memory retrieval of that object, and suppressed at the time of retrieval of other objects. Then, it became important to determine the neural network that drives the memory retrieval machinery in the IT cortex.

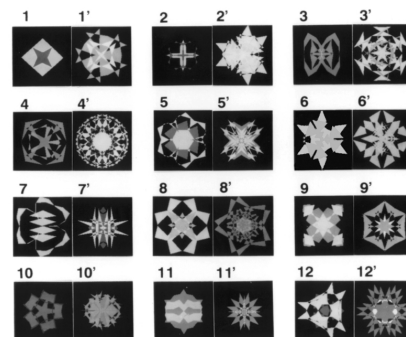

Figure 1 : Paired associates. Each pictures was created according to a fractal algorithm.

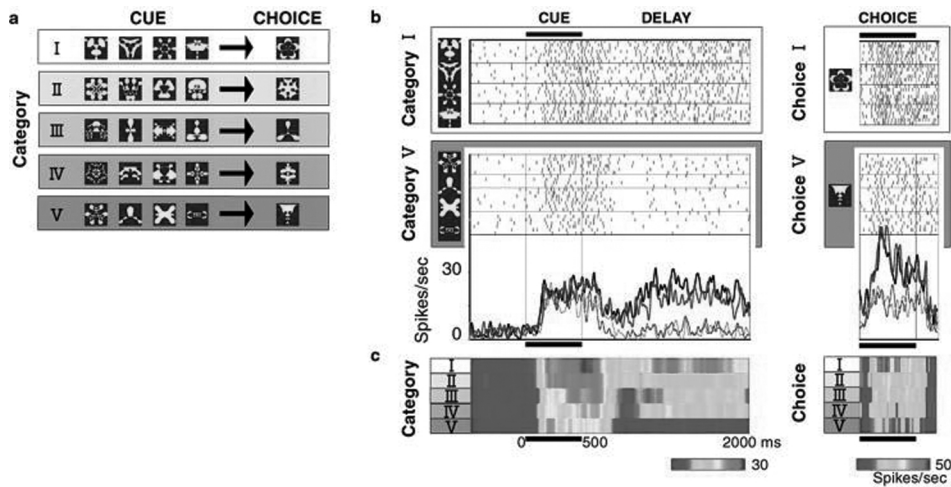

Figure 2 : Which information is carried via top-down signals? (a) A stimulus-stimulus association task. Twenty cue-pictures are randomly sorted into five categories. Each of the four cues in one category specifies a common choice. (b) Category-selective delay activity of an inferior temporal neuron. Delay activities were raised for all cues in Category I, but not for any cues in Category V (rastergrams, top-down condition). Choice responses are also strongest for Category I and weakest for Category V. Spike density functions show averaged activities across four cues in Category I (thick) and in Category V (thin) for both conditions (top-down, blue; bottom-up, black). (c) Spike density functions of the top-down response for five categories, as well as the choice responses, shown by a pseudo-colour coding. Note that the category-selective delay activity can predict choice selection.

3. Top-down activation through fronto-temporal pathway

A candidate component of the neural circuit is the top-down activation from the prefrontal cortex. The prefrontal cortex has been implicated in various executive processes, and its contribution to mnemonic functions, particularly in episodic memory and working memory, is repeatedly demonstrated in human neuroimaging studies. We attempted to directly test its contribution to memory retrieval control by the capacity for interhemispheric transfer of mnemonic signal through the anterior corpus callosum, a key structure interconnecting prefrontal cortices. We introduced the posterior-split-brain paradigm into the associative memory task in monkeys [23]. Long-term memory acquired through stimulus-stimulus association did not interhemispherically transfer via the anterior corpus callosum. Nonetheless, when a visual cue was presented to one hemisphere, the anterior callosum could instruct the other hemisphere to retrieve the correct stimulus specified by the cue. Therefore, although visual long-term memory is stored in the temporal cortex, memory retrieval is under the executive control of the prefrontal cortex.

In spite of predictions based on these behavioural experiments, no neuronal correlate of the top-down signal from the prefrontal cortex to IT cortex had been detected. We provided the first evidence of the existence of the top-down signal [14] by conducting single-unit recording in posterior-split-brain monkeys. In the absence of bottom-up visual inputs, single IT neurons were robustly activated by the top-down signal, which conveyed information on semantic categorization imposed by visual stimulus-stimulus association (Fig. 2). We also demonstrated that the

top-down signal had a longer latency by about 100 ms than the bottom-up signal. The longer latency is most likely ascribed to a multi-synaptic conduction delay that reflected the signal transformation within the prefrontal cortices.

Current Research and Future Prospects

Most of our current research is focused on the third question on the mechanisms of cognitive memory, that is, (3) What is the mechanism underlying reactivation of the representation on demand of voluntary recall?

Two complementary approaches are of interest in answering the above question. First, neuroimaging studies in humans can elucidate brain representations and their interactions in high-level memory processes, which have been conceptualized as retrieval attempt or contextual monitoring. Second, the well-analyzed neural representations in the monkey cortex should be compared with those in the human cortex. The comparison would provide strong evidence that couples active neural codes in the brain network with conscious experiences.

An example of our recent achievements along the first approach is the discovery of a neural correlate of the “feeling-of-knowing” [1]. The “feeling-of-knowing (FOK)” is a subjective sense of knowing a word before recalling it, and it provides us clues to understanding the mechanisms of human meta-memory systems. We investigated neural correlates for the FOK based on the recall-judgment-recognition paradigm. Event-related functional magnetic resonance imaging (fMRI) with parametric analysis was used. We found activations in the left dorsolateral, left anterior, bilateral inferior, and medial prefrontal cortices that signifi-

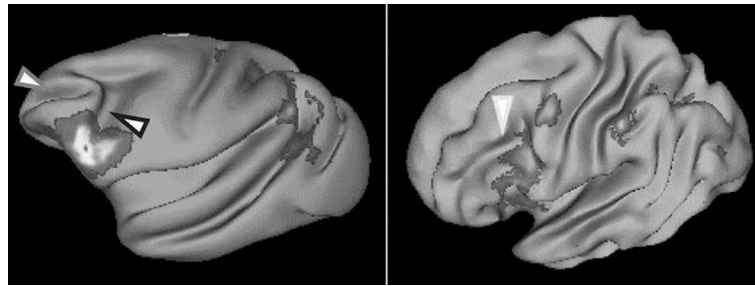

Figure 3 : Comparison of activated cortical areas in set-shifting of WCST in monkeys (left) and humans (right).

cantly increased as the FOK became greater. Furthermore, we demonstrated that the FOK-region in the right inferior frontal gyrus and a subset of the FOK-region in the left inferior frontal gyrus are not recruited for successful recall processes, suggesting their particular role in meta-memory processing.

Along the second approach, we have recently demonstrated that fMRI studies in macaque monkeys allow us to directly compare the brain activity of humans with that of monkeys with respect to high-level cognitive functions [2]. In this study, the functional brain organization of macaque monkeys and humans was directly compared by fMRI. Subjects of both species performed a modified Wisconsin Card Sorting Test that required behavioural flexibility in the form of cognitive set shifting. Equivalent visual stimuli and task sequence were used for the two species. We found transient activation related to cognitive set shifting in focal regions of the prefrontal cortex in both monkeys and humans. These functional homologs were located in cytoarchitecturally equivalent regions in the posterior part of the ventrolateral prefrontal cortex. This comparative imaging provides insights into the evolution of cognition in primates.

Various neuroimaging studies have been carried out to clarify cognitive functions of the human brain. Because most neuroimaging studies rely on the correlation between cognitive processes and brain activations, conjunction with other complementary methods, such as neuropsychological studies and transcranial magnetic stimulation, should be promoted to clarify the behavioural significance of observed brain activities. Emerging fMRI of the monkey brain enables us to directly compare the brain activity of humans with that of monkeys using the same modality. Therefore the monkey fMRI will make it possible to combine imaging studies with electrophysiology or lesion studies, and will hopefully lead to the understanding of the causal relationship between activated brain areas and cognitive functions. Since most of the detailed knowledge of anatomy and function of the cerebral cortex has come from studies in monkeys, sharing the same method among the studies of monkeys and humans would advance the understanding of the neural basis of human cognition.

Research Grants

1. A Grant-in-Aid for Specially Promoted Research, MEXT (07102006)
Neural mechanisms of cognitive memory system : Integration of functional magnetic resonance imaging method and molecular/cellular approaches.
¥ 215,000,000 (1995-1999)
2. A Grant-in-Aid for Specially Promoted Research, MEXT (Extension 07102006)
Neural mechanisms of cognitive memory system : Integration of functional magnetic resonance imaging method and molecular/cellular approaches.
¥309,000,000 (2000-2001)
3. A Grant-in-Aid for Specially Promoted Research, MEXT (14002005)
Brain distributed network : Integrative study based on functional MRI in monkeys
¥ 550,000,000 (2002-2006)

Select Publications

1. Kikyo, H., Ohki, K. and Miyashita, Y. Neural correlates for "feeling-of-knowing": an fMRI parametric analysis.
Neuron 36, 177-186, 2002.
2. Nakahara, K., Hayashi, T., Konishi, S. and Miyashita, Y. Functional MRI of macaque monkeys performing a cognitive set-shifting task.
Science 295, 1532-1536, 2002.
3. Konishi, S., Hayashi, T., Uchida, I., Kikyo, H., Takahashi, E. and Miyashita, Y. Hemispheric asymmetry in human lateral frontal cortex during cognitive set shifting.
Proc. Natl. Acad. Sci. USA 99, 7803-7808, 2002.
4. Hasegawa, I. and Miyashita, Y. Making categories: expert neurons look into key features.
Nature Neurosci. 5, 90-91, 2002.
5. Tokuyama, W., Okuno, H., Hashimoto, T., Li, X.Y. and Miyashita, Y. Selective *zif268* mRNA induction in the perirhinal cortex macaque of monkeys during formation of visual pair-association memory.
J. Neurochem. 81, 60-70, 2002.
6. Matsuzaki, M., Ellis-Davies, G.C.R., Nemoto, T., Miyashita, Y., Iino, M. and Kasai, H. Dendritic spine geometry is critical for AMPA receptors expression in hippocampal CA1 Pyramidal neurons.
Nature Neurosci. 4, 1086-1092, 2001.

7. Naya, Y., Yoshida, M. & Miyashita, Y. Backward spreading of memory retrieval signal in the primate temporal cortex. *Science* 291, 661-664, 2001.
8. Li, X.Y., Hashimoto, T., Tokuyama, W., Miyashita, Y. and Okuno H Spatio-temporal dynamics of BDNF mRNA induction in the vestibulo-olivary network during vestibular compensation. *J. Neurosci* 21, 2738-2748, 2001.
9. Miyashita, Y. and Farah, M.J. Cognitive neuroscience at the turn of the millennium. *Curr. Opin. Neurobiol.* 11, 147-149, 2001.
10. Nemoto, T., Kimura, R., Ito, K., Tachikawa, A., Miyashita, Y., Iino, M. and Kasai, H. Sequential replenishment mechanism of exocytosis in pancreatic acini. *Nature Cell Biol.* 3, 253-258, 2001.
11. Tokuyama, W., Okuno, H., Hashimoto, T., Li, Y.X. and Miyashita, Y. BDNF upregulation during declarative memory formation in monkey inferior temporal cortex. *Nature Neurosci.* 3, 1134-1142, 2000.
12. Embick, D., Marantz, A., Miyashita, Y., O'Neil W. and Sakai, K.L. A syntactic specialization for Broca's area. *Proc. Natl. Acad. Sci. USA* 97, 6150-6154, 2000.
13. Miyashita, Y. and Hayashi, T. Neural representation of visual objects : encoding and top-down activation. *Curr. Opin. Neurobiol.* 10, 187-194, 2000.
14. Tomita, H., Ohbayashi, M., Nakahara, K., Hasegawa, I. and Miyashita, Y. Top-down signal originating from the prefrontal cortex for memory retrieval. *Nature* 401, 699-703, 1999.
15. Maeda, H., Ellis-Davies, G.C.R., Ito, K., Miyashita, Y. and Kasai, H. Supralinear Ca²⁺ signaling by cooperative and mobile Ca²⁺ buffering in Purkinje neurons. *Neuron* 24, 989-1002, 1999.
16. Kasai, H., Kishimoto, T., Liu, T., Miyashita, Y., Podini, P., Grohovaz, F. and Meldolesi, J. Multiple and diverse forms of regulated exocytosis in wild-type and defective PC12 cells. *Proc. Natl. Acad. Sci. USA* 96, 945-949, 1999.
17. Konishi, S., Nakajima, K., Uchida, I., Kikyo, H., Kameyama, M. and Miyashita, Y. Common inhibitory mechanism in human inferior prefrontal cortex revealed by event-related functional MRI. *Brain* 122, 981-991, 1999.
18. Konishi, S., Kawazu, M., Uchida, I., Kikyo, H., Asakura, I. and Miyashita, Y. Contribution of working memory to transient activation in human inferior prefrontal cortex during performance of Wisconsin card sorting test. *Cerebral Cortex* 9, 745-753, 1999.
19. Okuno, H., Tokuyama, W., Li, Y-X., Hashimoto, T. and Miyashita, Y. Quantitative evaluation of neurotrophin and *trk* mRNA expression in visual and limbic areas along the occipito-temporo-hippocampal pathway in adult macaque monkeys. *J. Comp. Neurol.* 408, 378-398, 1999.
20. Uchida, I., Kikyo, H., Nakajima, K., Sekihara, K. and Miyashita, Y. Activation of lateral extrastriate areas during orthographic processing of Japanese characters studied with fMRI. *Neuroimage* 9, 208-215, 1999.
21. Ito, K., Miyashita, Y. and Kasai H Kinetic control of multiple forms of Ca²⁺ spikes by inositol trisphosphate in pancreatic acinar cells. *J. Cell Biol.* 146, 405-413, 1999.
22. Takahashi, N., Kadowaki, T., Yazaki, Y., Ellis-Davies, G.C.R., Miyashita, Y. and Kasai, H. Post-priming actions of ATP on Ca²⁺-dependent exocytosis in pancreatic beta cells. *Proc. Natl. Acad. Sci. USA* 96, 760-765, 1999.
23. Hasegawa, I., Fukushima, T., Ihara, T. and Miyashita, Y. Callosal window between prefrontal cortices : cognitive interaction to retrieve long-term memory. *Science* 281, 814-818, 1998.
24. Konishi, S., Nakajima, K., Uchida, I., Kameyama, M., Nakahara, K., Sekihara, K. and Miyashita, Y. Transient activation of inferior prefrontal cortex during cognitive set shifting. *Nature Neurosci.* 1, 80-84, 1998.
25. Konishi, S., Nakajima, K., Uchida, I., Sekihara, K. and Miyashita, Y. Temporally resolved no-go dominant brain activity in the prefrontal cortex revealed by functional magnetic resonance imaging. *Neuroimage* 5, 120, 1997.
26. Takahashi, N., Kadowaki, T., Yazaki, Y., Miyashita, Y. and Kasai, H. Multiple exocytotic pathways in pancreatic β cells. *J. Cell Biol.* 138, 55-64, 1997.
27. Ninomiya, Y., Kishimoto, T., Yamazawa, T., Ikeda, H., Miyashita, Y. and Kasai, H. Kinetic diversity in the fusion of exocytotic vesicles. *EMBO J.* 16, 929-934, 1997.
28. Ito, K., Miyashita, Y. and Kasai H. Micromolar and submicromolar Ca²⁺ spikes regulating distinct cellular functions in pancreatic acinar cells. *EMBO J.* 16, 242-251, 1997.
29. Higuchi, S. and Miyashita, Y. Formation of mnemonic neuronal responses to visual paired associates in inferotemporal cortex is impaired by perirhinal and entorhinal lesions. *Proc. Natl. Acad. Sci. USA*, 93, 739-743, 1996.
30. Naya, Y., Sakai, K. and Miyashita, Y. Activity of primate inferotemporal neurons related to a sought target in pair-association task. *Proc. Natl. Acad. Sci. USA*, 93, 2664-2669, 1996.
31. Kasai, H., Takagi, H., Ninomiya, Y., Kishimoto, T., Ito, K., Yoshida, A., Yoshioka, T. and Miyashita, Y. Two components of exocytosis and endocytosis in pheochromocytoma cells studied using caged-Ca²⁺ compounds. *J. Physiol.* 494, 53-65, 1996.
32. Ninomiya, Y., Kishimoto, T., Miyashita, Y. and Kasai, H. Ca²⁺-dependent exocytotic pathways in chinese hamster ovary fibroblasts revealed by a caged-Ca²⁺ compound.

- J. Biol. Chem.* 271, 17751-17754, 1996.
33. Sakai, K., Watanabe, E., Onodera, Y., Uchida, I., Kato, H., Yamamoto, E., Koizumi, H. and Miyashita, Y. Functional mapping of the human colour centre with echo-planar magnetic resonance imaging. *Proc. R. Soc. Lond. B* 261, 89-98, 1995.
 34. Miyashita, Y. : How the brain creates imagery: Projection to primary visual cortex. *Science* 268, 1719-1720, 1995.
 35. Okuno, H., Saffan, D.W. and Miyashita, Y. Subdivision-specific expression of Zif268 in the hippocampal formation of the Macaque monkey. *Neuroscience* 66, 829-845, 1995.
 36. Sakai, K., Watanabe, E., Onodera, Y., Itagaki, H., Yamamoto, E., Koizumi, H. and Miyashita, Y. Functional mapping of the human somatosensory cortex with echo-planar magnetic resonance imaging. *Magn. Reson. Med.* 33, 736-743, 1995.
 37. Sakai, K. and Miyashita, Y. Visual imagery : An interaction between memory retrieval and focal attention. *Trends Neurosci.* 17, 287-289, 1994.
 38. Mori, A., Takahashi, T., Miyashita, Y. and Kasai, H. Two distinct glutamatergic synaptic inputs to the striatal medium spiny neurones of neonatal rat and paired-pulse depression. *J. Physiol.* 476, 217-228, 1994.
 39. Kasai, H., Li, Yeu Xin and Miyashita, Y. Subcellular distribution of Ca²⁺ release channels underlying Ca²⁺ waves and oscillations in exocrine pancreas. *Cell* 74, 669-677, 1993.
 40. Miyashita, Y. Inferior temporal cortex: where visual perception meets memory. *Annu. Rev. Neurosci.* 16, 245-263, 1993.
 41. Sakai, K. and Miyashita, Y. Memory and imagery in the Temporal lobe. *Curr. Opin. Neurobiol.* 3, 166-170, 1993
 42. Miyashita, Y., Date, A. and Okuno, H. Configurational encoding of complex visual forms by single neurons of monkey temporal cortex. *Neuropsychologia* 31, 1019-1031, 1993.
 43. Maruyama, Y., Inooka, G., Li, Y., Miyashita, Y. and Kasai, H. Agonist-induced localized Ca²⁺ rises directly triggering exocytotic secretion in exocrine pancreas. *EMBO J.* 12, 3017-3022, 1993.
 44. Iino, M., Yamazawa, T., Miyashita, Y., Endo, M. and Kasai, H. Critical intracellular Ca²⁺ concentration for all-or-none Ca²⁺ spiking in single smooth muscle cells. *EMBO J.* 12, 5287-5291, 1993.
 45. Sakai, K. and Miyashita, Y. Neural organization for the long-term memory of paired associates. *Nature* 354, 152-155, 1991.
 46. Rolls, E.T., Miyashita, Y., Cahusac, P., Kesner, R.P., Niki, H., Feigenbaum, J. and Bach, L. Hippocampal neurons in the monkey with activity related to the place in which a stimulus is shown. *J. Neurosci.* 9, 1835-1845, 1989.
 47. Mori, K. and Miyashita, Y. Localized metabolic responses to optokinetic stimulation in the brain stem nuclei and the cerebellum investigated with the [¹⁴C]2-deoxyglucose method in rats. *Neuroscience* 30, 271-281 1989.
 48. Miyashita, Y., Rolls, E.T., Cahusac, P. and Niki, H. Activity of hippocampal formation neurons in the monkey related to a stimulus-response association task. *J. Neurophysiol.* 61, 669-678, 1989.
 49. Miyashita, Y. Neuronal correlate of visual associative long-term memory in the primate temporal cortex. *Nature* 335, 817-820, 1988.
 50. Miyashita, Y. and Chang, H.S. Neuronal correlate of pictorial short-term memory in the primate temporal cortex. *Nature* 331, 68-70, 1988.

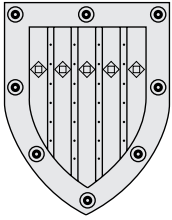

Department of Cellular and Molecular Physiology

Outline and Research Objectives

Knowledge comes to man through the door of the senses (Heraclitus). Using multidisciplinary approaches including electrophysiology, optical imaging, molecular / cell biology, and molecular genetics, we aim at better understanding of neuronal mechanisms for the sensory perception of the external world and for the emotional state induced in the brain by the sensory inputs. For this purpose we are currently analyzing the central nervous system for olfaction, a sensory modality that has a strong influence to human emotion. Another major research focus of this department is to understand cellular and molecular mechanisms for contact-mediated interactions between neurons and immune cells that occur in pathological and physiological conditions.

Faculties and Students

Professor and Chair	Kensaku Mori, Ph. D. (May 1999 ~)
Lecturer	Masahiro Yamaguchi, M.D., Ph. D.
Associate2
Graduate student12
Research student1
Secretary1

Past Research and Major Accomplishments

K. Mori and colleagues have been studying the functional organization of the olfactory nervous system for nearly 28 years. Major accomplishment of our research group before 1999 includes (1) a systematic functional and structural analysis of the neuronal circuits in the mammalian olfactory bulb, the first center for the processing of olfactory information in the brain, (2) the finding that individual principal neurons in the olfactory bulb respond selectively to a range of odorants having common molecular structures, and (3) the finding of zone-to-zone axonal connectivity pattern between olfactory sensory epithelium and the olfactory bulb. After K. Mori's arrival at the Department of Cellular and Molecular Physiology in May 1999, we further extended our previous studies and found a clue for understanding the spatial organization of the 'odor map' in the olfactory bulb (Fig.1; e.g., Mori et al., *Science*, 1999, Uchida et al., *Nature Neurosci.*, 2000., Nagao et al., *NeuroReport*, 2000). These studies as well as our novel molecular genetic approaches (Yoshihara et al., *Neuron* 1999) formed a basis for current and future studies on the 'odor maps' in the olfactory bulb and olfactory cortex (e.g., Inaki et al., *Eur. J. of Neurosci.*, 2002).

We previously found several novel neuronal cell adhesion molecules and analyzed their functional roles in the formation of neuronal circuit in the brain

(e.g., telencephalin (TLCN), Yoshihara et al., *Neuron*, 1994; OCAM, Yoshihara et al., *J. Neurosci.*, 1997). We are currently extending the analysis of the functional roles of these cell adhesion molecules using TLCN-deficient mice (in collaboration with Prof. Mishina) and OCAM-deficient mice. During the course of the analysis of TLCN, we unexpectedly found that the binding between TLCN and its counterreceptor LFA-1 mediated the interaction between neurons and

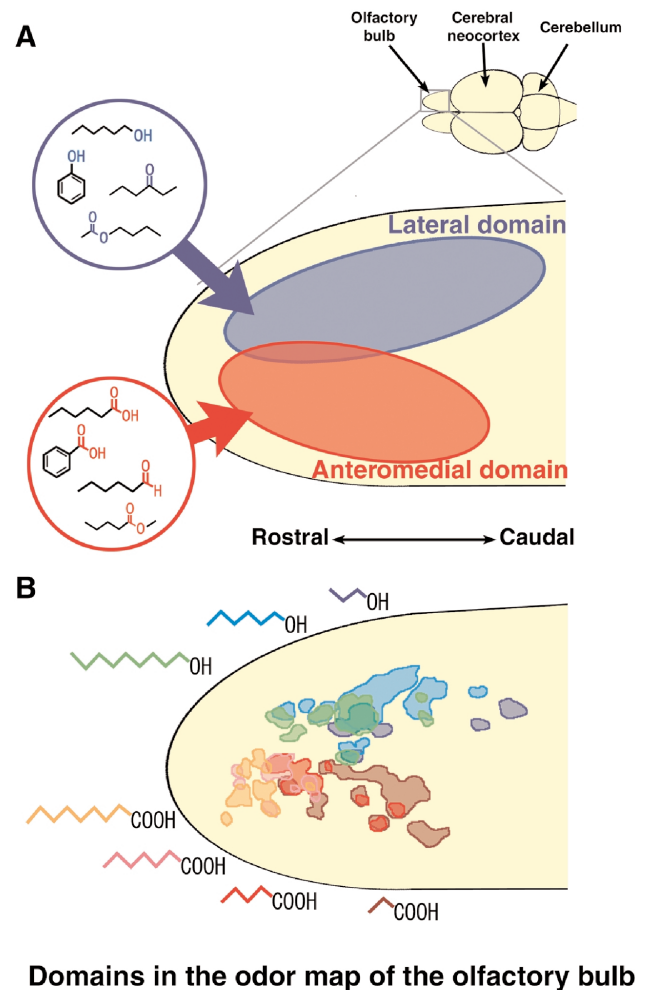

immune cells (Mizuno et al., J. B. C., 1997; Tian et al., J. Cell Biol., 2000, Eur. J. Immunol., 2000, J. Immunol., 1997). We thus developed a co-culture assay system to examine the contact-mediated interactions between neurons and immune cells.

Our group generated transgenic mice in which newly generated neurons are visualized in the brain by the green fluorescent protein (Yamaguchi et al., NeuroReport, 2000). Using the transgenic mice, we are now studying the neurogenesis and neuron-elimination in the adult brain.

Current Research

Current research programs and targets can be categorized into the following four topics.

(1) Functional analysis of the neuronal circuits in the central olfactory nervous system

An astonishing feature of the olfactory system is its ability to distinguish among more than 400,000 different odorants and among countless number of odorants-mixtures, each having specific 'odor'. Using optical imaging and electrophysiological methods, we are studying the 'odor maps' in the central olfactory system to understand the logic employed by the olfactory system for discrimination among numerous odorants and for perception and learning of the olfactory image of objects. The target regions for the mapping include the olfactory bulb and several regions of the olfactory cortex (e.g., piriform cortex and olfactory tubercle). In addition, odorants having pleasant or unpleasant 'odor' are used to map the brain regions and to elucidate neuronal mechanisms responsible for the emotional states of the brain.

(2) Neurogenesis and neuron-elimination in the adult brain

Olfactory nervous system has an unusual capacity to generate neurons throughout life. The sensory neurons in the nasal epithelium and the local interneurons in the olfactory bulb are turning over continuously even in the adult. Therefore, we choose the olfactory system as a model system with which to study the molecular and cellular mechanisms for the recruitment of newly generated neurons into the adult central nervous system and for the selective elimination of damaged neurons from the functional neuronal circuit. Molecular-genetic and physiological methods are combined to analyze the mechanisms of the neuron-recruitment and neuron-elimination. The knowledge of the new-neuron recruitment into the functioning neuronal circuit should be of critical importance in the remedy of neurological diseases that accompany neuron loss.

(3) Molecular and cellular mechanisms for the axonal recognition of specific target neurons and for the formation of specific neuronal circuits

During development, growing axons, including the axons from olfactory sensory neurons, can find their specific target neurons and form functional neuronal circuits. Recent studies on olfactory sensory neurons demonstrate a remarkable relationship between the selection of a single odorant receptor gene among a repertoire of 1000 and the address of the axon-projection target-glomeruli in the olfactory bulb. Such knowledge on the detailed address of the axon targets is currently available only in the olfactory system. We apply proteomics approaches to the olfactory axon address system to elucidate molecular mechanisms for the olfactory axon guidance to the target glomeruli and for the formation of specific synaptic connections with target neurons in the olfactory bulb.

(4) Cellular and molecular mechanisms for the contact-mediated interactions between neurons and immune cells in physiological and pathological conditions

Immune cells rarely meet central neurons in physiological conditions because of the blood brain barrier. However, a massive infiltration of immune cells into the brain occurs under many pathological conditions, suggesting that immune cells may directly interact with central neurons. To understand the nature and consequence of the direct interaction between immune cells and neurons, we are examining the change in neuronal morphology and physiological state of primary cultured neurons following the co-culture with immune cells. In addition, we are currently focusing on telencephalon-neuron specific membrane protein, telencephalin (TLCN), which bind to LFA-1 integrin expressed by leukocytes. Since the soluble form of TLCN can be detected in the serum and cerebrospinal fluid of patients of several neurological diseases, we are developing a sensitive ELISA assay system to detect the soluble TLCN for monitoring the possible neuronal damage in the telencephalic regions of the patient brain.

Future Prospects

We plan to further pursue the current research projects that are described above.

Topic (1): In addition to the current studies, we will start a new project aiming at the elucidation of neuronal substrate for the olfactory memory. In the future study an emphasis will be placed on the search for the behaviorally-relevant olfactory sensory maps (e.g., food-odor maps) at higher olfactory centers including the olfactory cortex and amygdala of the

rodent brain. An emphasis will be placed also on the search for the neuronal mechanisms associated with odorant-induced emotional changes. These studies will hopefully provide scientific basis for the therapeutic use of odorants and for the treatment of diseases in the olfactory nervous system.

Topic (2): We pursue to understand molecular and cellular mechanisms how the newly-generated neurons are integrated into the existing neuronal circuit and how the damaged-neurons are removed from the circuit without damaging the function of the neuronal circuit in the adult brain.

Topic (3): Based on our initial proteomic approaches, we now have the list of candidate molecules that might be involved in the olfactory axon target recognition. Systematic functional assays will be performed to pin-down the molecular complexes that are responsible for the proper recognition of the olfactory axon targets. The knowledge of the molecular mechanism for target recognition in the olfactory system will be of prime importance in understanding the molecular mechanism for the formation of the neuronal circuits in whole brain regions.

Topic (4): Cellular and molecular analysis of the contact-mediated interaction between immune cells and neurons will be further pursued using the co-culture assay system. In addition, we will start a systematic analysis of immune cell-mediated effects in the brain of the TLCN-deficient mice. Collaborative research with clinical laboratories will be pursued to establish the methods for detecting and measuring serum TLCN for the diagnosis of possible damage of telencephalic neurons in the brain.

Research Grants

1. Grant-in-Aid for Creative Scientific Research (JSPS) (2001-2005, ~65 millions yen / year)
2. Grant-in-Aid for Scientific Research on Priority Areas (B) (MEXT) (1999-2002, ~9.6 millions yen / year)
3. Research Grant from the Human Frontier Science Program (1999-2001, 59000 USD / year)
4. Grant-in-Aid for Exploratory Research (MEXT) (2001-2002, 1.3 millions yen / year)
5. Research Grant from Mitsubishi Foundation (2000, 7.5 millions yen)

Select Publications (1992~2002)

1. Mori, K, Mataga, N, and Imamura, K. Differential specificities of single mitral cells in rabbit olfactory bulb for a homologous series of fatty acid odor molecules. *J. Neurophysiol.*, 67, 786-789, 1992.

2. Kimura, T, Tanizawa, O, Mori, K, Brownstein, M, and Okayama, H. Structure and expression of a human oxytocin receptor. *Nature*, 356, 526-529, 1992.
3. Tani, A, Yoshihara, Y, and Mori, K. Increase in cytoplasmic free Ca²⁺ elicited by noradrenalin and serotonin in cultured local interneurons of mouse olfactory bulb. *Neuroscience*, 49, 193-199, 1992.
4. Imamura, K, Mataga, N, and Mori, K. Coding of odor molecules by mitral/tufted cells in rabbit olfactory bulb: I. Aliphatic compounds. *J. Neurophysiol.*, 68, 1986-2002, 1992.
5. Kimura, T, Azuma, C, Saji, F, Takemura, M, Tokugawa, Y, Miki, M, Ono, M, Mori, K, and Tanizawa, O. Estimation by an electrophysiological method of the expression of oxytocin receptor mRNA in human myometrium during pregnancy. *J. Steroid Biochem. Mol. Biol.*, 42, 253-258, 1992.
6. Ishihara, T, Shigemoto, R, Mori, K, Takahashi, K, and Nagata, S. Functional expression and tissue distribution of a novel receptor for vasoactive intestinal polypeptide. *Neuron*, 8, 811-819, 1992.
7. Yoshihara, Y, Katoh, K, and Mori, K. Odor stimulation causes disappearance of R4B12 epitope on axonal surface molecule of olfactory sensory neurons. *Neuroscience*, 53, 101-110, 1993.
8. Mochizuki-Oda, N, Negishi, M, Mori, K, and Ito, S. Arachidonic acid activates cation channels in bovine adrenal chromaffin cells. *J. Neurochem.*, 61, 1882-1890, 1993.
9. Mori, K. Molecular and cellular properties of mammalian primary olfactory axons. *Microscopy Res. Technique*, 24, 131-141, 1993.
10. Hashimoto, H, Ishihara, T, Shigemoto, R, Mori, K, and Nagata, S. Molecular cloning and tissue distribution of a receptor for pituitary adenylate cyclase activating polypeptide. *Neuron*, 11, 333-342, 1993.
11. Katoh, K, Koshimoto, H, Tani, A, and Mori, K. Coding of odor molecules by mitral/tufted cells in rabbit olfactory bulb: II Aromatic compounds. *J. Neurophysiol.*, 70, 2161-2175, 1993.
12. Nemoto, Y, Ikeda, J, Katoh, K, Koshimoto, H, Yoshihara, Y, and Mori, K. R2D5 antigen: a calcium-binding phosphoprotein predominantly expressed in olfactory receptor neurons. *J. Cell Biol.*, 123, 963-976, 1993.
13. Mori, K, and Shepherd, G. M. Emerging principles of molecular signal processing by mitral/tufted cells in the olfactory bulb. *Seminars in Cell Biol.*, 5, 65-74, 1994.
14. Koshimoto, H, Katoh, K, Yoshihara, Y, Nemoto, Y, and Mori, K. Immunohistochemical demonstration of embryonic expression of an odor receptor protein and its distribution in the rat olfactory epithelium. *Neurosci. Lett.*, 169, 73-76, 1994.
15. Yoshihara, Y, Oka, S, Nagata, S, Watanabe, Y, Kagamiyama, H, and Mori, K. ICAM-related neuronal glycoprotein, telencephalin, with brain segment-specific expression. *Neuron*, 12, 541-553, 1994.

16. Yoshihara, Y, Kawasaki, M, Tani, A, Tamada, A, Nagata, S, Kagamiyama, H, and Mori, K. BIG-1: a new TAG-1/F3-related member of the immunoglobulin superfamily with neurite outgrowth-promoting activity. *Neuron*, 13, 415-426, 1994.
17. Mori, K, and Yoshihara, Y. Molecular recognition and olfactory processing in the mammalian olfactory system. *Prog. Neurobiol.*, 45, 585-619, 1995.
18. Yokoi, M, Mori, K, and Nakanishi, S. Refinement of odor molecule tuning by dendrodendritic synaptic inhibition in the olfactory bulb. *Proc. Natl. Acad. Sci. USA*, 92, 3371-3375, 1995.
19. Yoshihara, Y, Kawasaki, M, Tamada, A, Nagata, S, Kagamiyama, H, and Mori, K. Overlapping and differential expression of BIG-2, BIG-1, TAG-1, and F3: Four members of an AxCAM subgroup of the immunoglobulin superfamily. *J. Neurobiol* 28, 51-69, 1995.
20. Mori, K. Relation of chemical structure to specificity of response in olfactory glomeruli. *Current Opin. Neurobiol.*, 5, 467-474, 1995.
21. Hashimoto, H, Nogi, H, Mori, K, Ohishi, H, Shigemoto, R, Yamamoto, K, Matsuda, T, Mizuno, N, Nagata S. and Baba, A. Distribution of the mRNA for a pituitary adenylate cyclase-activating polypeptide receptor in the rat brain: an in situ hybridization study. *J. Comp. Neurol.* 371: 567-577, 1996.
22. Mizuno, T, Yoshihara, Y, Inazawa, K, Kagamiyama, H, and Mori, K., cDNA cloning and chromosomal localization of the human telencephalin and its distinctive interaction with LFA-1 integrin. *J. Biol. Chem.* 272, 1156-1163, 1997.
23. Tian, L, Yoshihara, Y, Mizuno, T, Mori, K, and Gahmberg, C G. The neuronal glycoprotein, telencephalin, is a cellular ligand for CD11a/CD18, but not for CD11b/CD18 and CD11c/CD18 leukocyte integrins. *J. Immunol.* 158, 928-936, 1997.
24. Fujimori, K E, Takauji, R, Yoshihara, Y, Tamada, A, Mori, K, and Tamamaki, N. A procedure for in situ hybridization combined with retrograde labeling of neurons: Application to the study of cell adhesion molecule expression in DiI-labeled rat pyramidal neuron. *J. Histochem. and Cytochem.* 45, 455-459, 1997.
25. Hino, H, Mori, K, Yoshihara, Y, Iseki, E, Akiyama, H, Nishimura, T, Ikeda, K and Kosaka K. Reduction of telencephalin immunoreactivity in the brain of patients with Alzheimer's disease. *Brain Res.* 753, 353-357, 1997.
26. Yoshihara, Y, Kawasaki, M, Tamada, A, Fujita, H, Hayashi, H, Kagamiyama, H and Mori, K. OCAM: a new member of the neural cell adhesion molecule family related to zone-to-zone projection of olfactory and vomeronasal axons. *J. Neurosci.* 17, 5830-5842, 1997.
27. von Campenhausen, H, Yoshihara, Y, and Mori, K. OCAM reveals segregated mitral/tufted cell pathways in developing accessory olfactory bulb. *NeuroReport* 8, 2607-2612, 1997.
28. Yoshihara, Y and Mori, K. Basic principles and molecular mechanisms of olfactory axon pathfinding. *Cell and Tissue Res.* 290, 457-463, 1997.
29. Sugino, H, Yoshihara, Y, Copeland, N G, Gilbert, D J, Jenkins, N A and Mori, K. Genomic organization and chromosomal localization of the mouse telencephalin gene, a neuronal member of the ICAM family. *Genomics* 43, 209-218, 1997.
30. Tamada, A, Yoshihara, Y, and Mori, K. Dendrite-associated adhesion molecule, telencephalin, promotes neurite out growth. *Neuroscience Letters*, 240, 163-166, 1998.
31. Benson, D, Yoshihara, Y, and Mori, K. Polarized distribution and cell -type specific localization of telencephalin, an ICAM-related neuronal cell adhesion molecule. *J. Neurosci. Res.* 52, 43-53, 1998.
32. Sakurai, E, Hashikawa, T, Yoshihara, Y, Kaneko, S, Sato, M. and Mori, K. Involvement of dendritic adhesion molecule telencephalin in hippocampal long-term potentiation. *NeuroReport*, 9, 881-886, 1998.
33. Mori, K, Nagao, H. and Sasaki, Y. F. Computation of molecular information in mammalian olfactory system. *Network: Computation in Neuronal Systems*, 9, 79-102, 1998.
34. Yoshihara, Y, Mizuno, T, Nakahira, M, Kawasaki, M, Watanabe, Y, Kagamiyama, H, Jishage, K, Ueda, O, Suzuki, H, Tabuchi, K, Sawamoto, K, Okano, H, Noda, T. and Mori, K. A genetic approach to visualization of multi-synaptic neuronal pathways using plant lectin transgene. *Neuron*, 22, 33-41, 1999.
35. Arii, N, Mizuguchi, M, Mori, K. and Takashima S. Development of telencephalin in human cerebrum. *Microscop. Res. Tech.* 46, 18-23, 1999.
36. Kashiwadani, H, Sasaki, Y, Uchida, N. and Mori, K. Synchronized oscillatory discharges of mitral/tufted cells with different molecular receptive ranges in the rabbit olfactory bulb. *J. Neurophysiol.*, 82, 1786-1792, 1999.
37. Mori, K, Nagao, H and Yoshihara, Y The olfactory bulb: coding and processing of odor molecule information. *Science*, 286, 711-715, 1999.
38. Mizuno, T, Yoshihara, Y, Kagamiyama, H, Ohsawa, K, Imai, Y, Kohsaka, S, and Mori, K. Neuronal adhesion molecule telencephalin induces rapid cell spreading of microglia. *Brain Research*, 849, 58-66, 1999.
39. von Campenhausen, H. and Mori, K. Convergence of segregated pheromonal pathways from the accessory olfactory bulb to the cortex. *Eur. J. of Neurosci.*, 12, 33-46, 2000.
40. Tian, L, Kilgannon, P, Yoshihara, Y, Mori, K, Gallatin, W M, Carpen, O. and Gahmberg, C G. Binding of T lymphocytes to hippocampal neurons through ICAM-5 (telencephalin) and characterization of its interaction with leukocyte integrin CD11a/CD18. *Eur. J. of Immunology*, 30, 810-818, 2000.
41. Mori, K, von Campenhausen, H, and Yoshihara, Y. Zonal organization of the mammalian main and

- accessory olfactory systems. *Phil. Trans. R. Soc. Lond. B*, 355, 1801-1812, 2000.
42. Yamaguchi, M, Saito, H, Suzuki, M. and Mori, K. Visualization of neurogenesis in the central nervous system using nestin promoter-GFP transgenic mice. *NeuroReport*, 11, 1991-1996, 2000.
 43. Tian, L, Nyman, H, Kilgannon, P, Yoshihara, Y, Mori, K, Anderson, L C, Kaukinen, S, Rauvala, H, Gallatin, W M and Gahmberg, C G. Intercellular adhesion molecule-5 induces dendritic outgrowth by homophilic adhesion. *J. Cell Biol.*, 150, 243-252, 2000.
 44. Nagao, H, Yoshihara, Y, Mitsui, S, Fujisawa, H, and Mori, K. Two mirror-image sensory maps with domain organization in the mouse main olfactory bulb. *NeuroReport*, 11, 3023-3027, 2000.
 45. Uchida, N, Takahashi, Y K, Tanifuji, M, and Mori, K. Odor maps in the mammalian olfactory bulb: domain organization and odorant structural features. *Nature Neurosc.*, 3, 1035-1043, 2000.
 46. Nemoto, Y, Kearns, B G, Wenk, M R, Chen, H, Mori, K, Alb, J G Jr., De Camilli, P and Bankaitis, V A. Functional characterization of a mammalian Sac1 and mutants exhibiting substrate-specific defects in phosphoinositide phosphatase activity. *J. Biol. Chem.*, 44, 34293-34305, 2000.
 47. Arii N, Mizuguchi, M, Mori, K, and Takashima, S. Ectopic expression of telencephalin in brains with holoprosencephaly. *Acta Neuropathol.* 100, 506-512, 2000.
 48. Tatura H, Nagao, H, Tamada, A, Sasaki, S, Kohri, K, Mori, K. Developing germ cells in mouse testis express pheromone receptors. *FEBS letters*, 488, 139-144, 2001.
 49. Mizuno T, Kawasaki, M, Nakahira, M, Kagamiyama, H, Kikuchi, Y, Okamoto, H, Mori, K, and Yoshihara, Y. Molecular diversity in zebrafish NCAM family: three members with distinct VASE usage and distinct localization. *Mol. and Cell. Neurosci.*, 18, 119-130, 2001.
 50. Sawamoto K, Nakao N, Kakishita K, Ogawa Y, Toyama Y, Yamamoto A, Yamaguchi M, Mori K, Goldman S A, Itakura T and Okano H. Generation of dopaminergic neurons in the adult brain from mesencephalic precursor cells labeled with a nestin-GFP transgene. *J. Neurosci.*, 21, 3895-3903, 2001.
 51. Inaki K, Takahashi, Y K, Nagayama, S and Mori K. Molecular-feature domains with posterodorsal-anteroventral polarity in the symmetrical sensory maps of the mouse olfactory bulb: mapping of odourant-induced Zif268 expression. *Eur. J. of Neurosci.*, 15, 1563-1574, 2002.
 52. Sugitani Y, Nakai, S, Minowa, O, Nishi, M, Jishage, K, Kawano, H, Mori, K, Ogawa, M, and Noda, T. Brn-1 and Brn-2 share crucial roles in the production and positioning of mouse neocortical neurons. *Genes and Development*, 16, 1760-1765, 2002.
 53. Nagao H, Yamaguchi, M, Takahashi, Y, and Mori, K. Grouping and representation of odorant receptors in domains of the olfactory bulb sensory map. *Microscopy Res. & Technique* 58, 168-175, 2002.

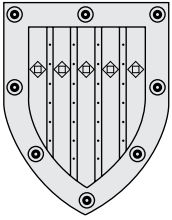

Department of Neurophysiology

Outline and Research Objectives

Our laboratory was founded in 1953 as a Department of Brain Physiology in Institute for Brain Research, University of Tokyo Faculty of Medicine, and in 1996 integrated into University of Tokyo Graduate School of Medicine. We have been teaching Neurophysiology to undergraduate students in Medical School, and Master and PhD course students. As for research, using patch clamp techniques in combination with molecular techniques, we aim at elucidating cellular and molecular mechanisms underlying synaptic transmission and modulation. We are particularly interested in dynamic changes at CNS synapses during postnatal development.

Synapses in the CNS play pivotal roles in neuronal integration and plasticity. During ontogeny CNS synapses undergo protein reformations, thereby establishing mature and differentiated synaptic functions. Synapses also undergo changes in response to electrical and chemical stimuli. Various proteins in the presynaptic and postsynaptic cells are involved in such changes, and it is important to determine the role of these proteins in synaptic functions and modulations. To this end, we combine electrophysiological, molecular and morphological techniques to synapses visually identified in the CNS slices. In the rodent auditory brainstem there is a giant excitatory synapse called the calyx of Held. At this synapse it is possible to make simultaneous whole-cell recordings from a presynaptic terminal and a postsynaptic target cell (Fig. 1). Furthermore, various molecules can be loaded into a nerve terminal via whole-cell pipette perfusion during the recording (Fig.2). The large structure of this synapse also allows us to identify presynaptic proteins immunocytochemically, and even to follow translocation of presynaptic molecules upon stimulation. With these approaches in combination with genetic manipulations and protein overexpressions, we aim at addressing the molecular basis underlying synaptic functions.

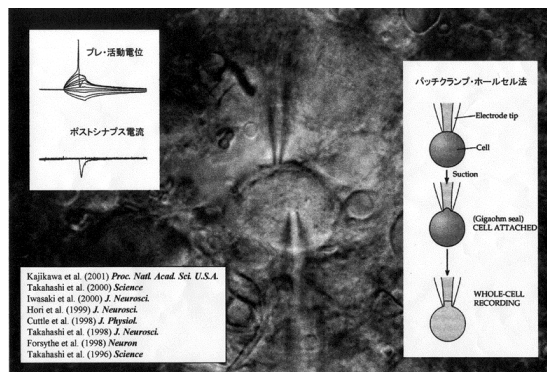

Fig. 1 Simultaneous pre- and postsynaptic whole cell recordings at the calyx of Held. Inset records on the left show a presynaptic action potential and excitatory postsynaptic currents (EPSC). Righthand inset illustrates the procedure of patch-clamp whole-cell recording method.

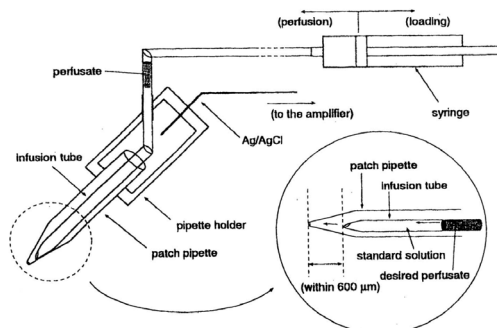

Fig. 2 Illustration of pipette perfusion system. A tube pulled from Eppendorf yellow tip is inserted into the patch pipette with its tip about 600 μm from the tip of the patch pipette.

Faculties and Students

Professor and Chair	Tomoyuki Takahashi MD, PhD (appointed since 1993)
Lecturer	Tetsuhiro Tsujimoto MD, PhD
Associate1
Postdoctoral Fellow2
Graduate Students9
Technical Assistant1
Secretary2

Past Research and Major Accomplishments

1. In simultaneous pre- and postsynaptic recordings at the calyx of Held synapse, we identified the target of presynaptic inhibition via metabotropic glutamate receptors and GABA_B receptors as being the voltage-dependent Ca²⁺ channel (Takahashi et al., Science 1996, J Neurosci, 1998), and that βγ subunits of the trimeric G protein G_o mediate the presynaptic inhibition (Kajikawa et al, 2001 PNAS).
2. We identified that phorbol ester stimulates exocytotic machinery downstream of Ca²⁺ influx thereby causing synaptic facilitation. By loading inhibitory peptides into the nerve terminal, we also clarified that both εPKC (Fig. 4a) and the Munc13-Doc2α interaction (Fig. 4b) underlie the phorbol ester-induced facilitatory mechanism (Hori et al., J Neurosci 1998; Saitoh et al, 2002).
3. We found that Ca²⁺ channel types mediating CNS synaptic transmission switch during development (Iwasaki et al, J Neurosci 2000).
4. By loading G protein-related compounds into the calyx of Held nerve terminal, we clarified that the main role of presynaptic G proteins is to accelerate the replenishment of synaptic vesicles depleted after massive release (Takahashi et al. Science 2000).
5. We have demonstrated that the quantal analysis established at the neuromuscular junction is applicable to the CNS synapse (Sahara & Takahashi, J Physiol 2001).
6. We found that NMDA receptors are unfavorable for the reliability of fast synaptic transmission, and that their developmental decline regulated by auditory activity at the calyx of Held synapse differentiates the synapse into the high-fidelity one (Futai et al., J Neurosci 2001)

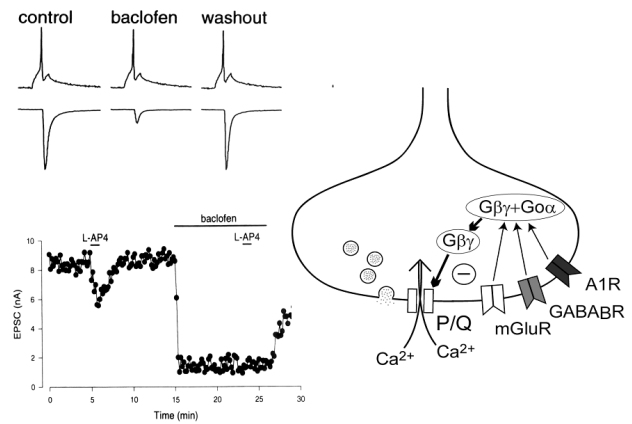

Fig. 3 Presynaptic inhibitory effect of baclofen occludes that of L-AP4, suggesting that GABA_B and metabotropic glutamate receptors share a common intracellular mechanism for presynaptic inhibition. Righthand illustration summarizes our current conclusion. Adenosine A1 receptors also share the same mechanism (Kimura and Takahashi, unpublished observation).

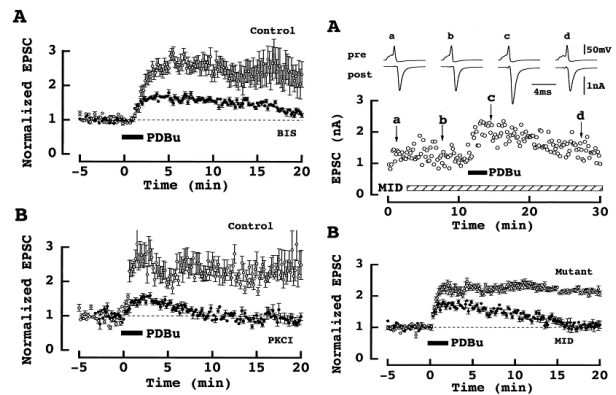

Fig. 4 Left column, Phorbol ester-induced EPSC potentiation is attenuated by the PKC inhibitor BIS (A) or PKC inhibitory peptide directly loaded into the calyceal terminal (B). Right column, The Mid peptide, which interferes with the Doc2α-Munc13-1 interaction attenuated the phorbol ester-induced EPSC potentiation.

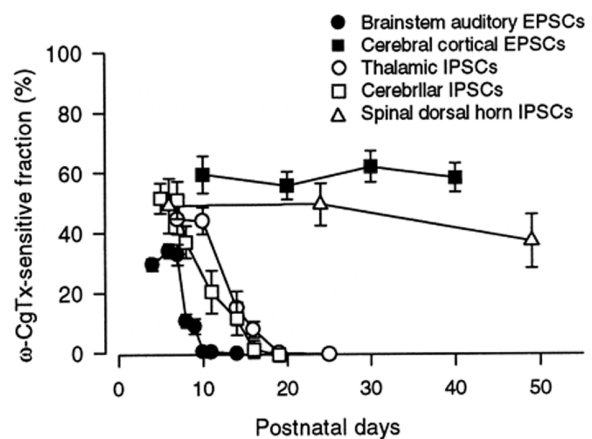

Fig. 5 Synaptic currents mediated by presynaptic N-type Ca²⁺ channels at 5 different central synapses. At 3 synapses, contribution of N-type Ca²⁺ channels to synaptic transmission decline and disappear with postnatal development, whereas at other 2 synapses it remained unchanged throughout development.

7. We found that presynaptic Ca²⁺ currents undergo facilitation by repetitive stimulation (Forsythe et al, 1998 Neuron) via acceleration of their gating kinetics (Cuttle et al., 1998 J Physiol) and that this

facilitation is mediated by the Ca^{2+} binding protein NCS-1 (Tsujimoto et al, 2002 Science).

- We found that cytoplasmic glutamate concentration in the nerve terminal directly affects the vesicular content of glutamate and that postsynaptic AMPA and NMDA receptors are not saturated by a single packet of vesicular transmitter (Ishikawa et al, 2002 Neuron).

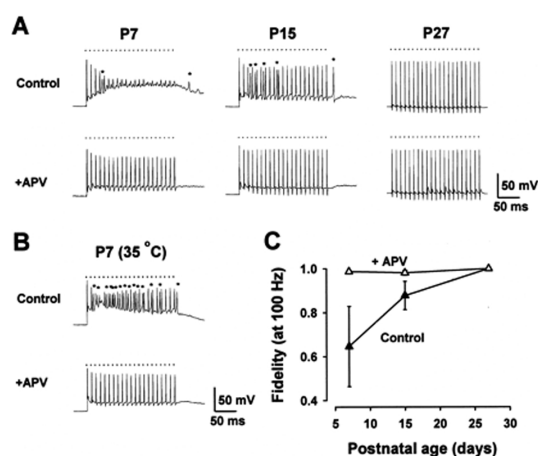

Fig. 6 Postsynaptic action potentials in response to presynaptic stimulation at 100 Hz at the developing calyx of Held synapse in mice. As mice mature fidelity of transmission increases, whereas blocking NMDA receptors using APV increases the fidelity at all ages.

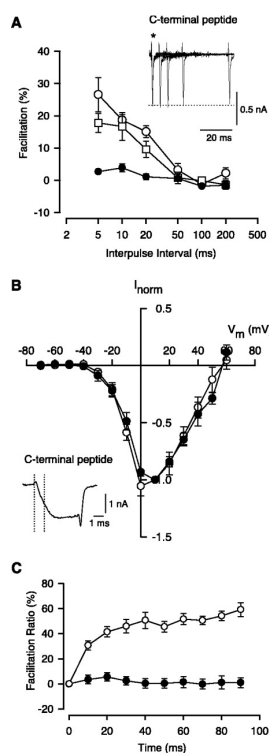

Fig. 7 The NCS-1 C-terminal peptide, when loaded into the calyx of Held presynaptic terminal, blocked the activity-dependent facilitations of presynaptic P/Q-type Ca^{2+} currents in a paired pulse protocol (A) and in a tetanic stimulation (100 Hz) protocol (C). The peptide had no effect on the current voltage relationship of presynaptic Ca^{2+} currents.

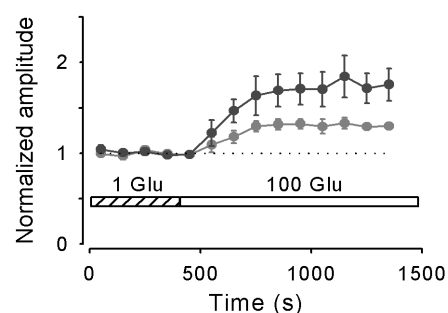

Fig. 8 Switching the L-glutamate concentration in the presynaptic whole-cell pipette from 1 mM to 100 mM markedly potentiated both quantal (blue) and evoked (red) EPSCs at the calyx of Held synapse at physiological temperature.

Current Research

1. Identification of presynaptic potassium channels involved in regulation of transmitter release.
2. Clarification on the developmental changes in the quantal synaptic responses.
3. Mechanism and roles of presynaptic adenosine receptors.
4. Developmental changes in the size of presynaptic Ca^{2+} domain.
5. Identification in the target protein downstream of ϵPKC .
6. Clarification in the different properties between presynaptic N-type and P/Q-type Ca^{2+} channels.

Future Prospects

1. To elucidate the minimal essential molecules required for short-term and long-term synaptic plasticity.
2. To clarify the molecular basis underlying the developmental speeding in the excitatory synaptic currents.
3. To clarify the presynaptic factor(s) determining the release probability.

Research Grants (in the past 5 years)

1996-2000

Research for the Future Program by the Japan Society of Promotion of Sciences "Molecular mechanisms of central synaptic modulation underlying the memory formation" ¥ 317,092,000

2001-2002

Grant-in-Aid for Specially promoted Research from the Ministry of Education, Culture, Sports, Science and Technology "Cellular and molecular mechanisms underlying postnatal development and differentiation of central synapses" ¥216,000,000

Select Publications

1. Ishikawa T, Sahara, Y, Takahashi T. A single packet of transmitter does not saturate postsynaptic glutamate receptors. *Neuron* 34, 613-621, 2002.
2. Tsujimoto T, Jeromin A, Saitoh N, Roder JC and Takahashi T Neuronal calcium sensor 1 and activity-dependent facilitation of P/Q-type calcium currents at presynaptic nerve terminals. *Science* 275,2276-2279, 2002.
3. Saitoh N., Hori T. & Takahashi T. Activation of the epsilon isoform of protein kinase C in the mammalian nerve terminal. *Proc. Natl. Acad. Sci. USA.* 98,14017-14021, 2001.
4. Sahara Y. & Takahashi T. Quantal components of the excitatory postsynaptic currents at a rat central auditory synapse. *J. Physiol. (London)* 536,189-197, 2001.
5. Iwasaki S. & Takahashi T. Developmental regulation of transmitter release at the calyx of Held in rat auditory brainstem. *J.Physiol. (London)* 534,861-871, 2001.
6. Kajikawa Y., Saitoh N.& Takahashi T. GTP-binding protein $\beta\gamma$ subunits mediate presynaptic calcium current inhibition by GABA_B receptor. *Proc. Natl. Acad. Sci.U.S.A* 98,8054-8058, 2001.
7. Ishikawa T. & Takahashi T. Mechanisms underlying presynaptic facilitatory effect of cyclothiazide at the calyx of Held of juvenile rats. *J. Physiol. (London)* 533, 423-431, 2001.
8. Futai K., Okada M., Matsuyama K. & Takahashi T. High-fidelity transmission acquired via a developmental decrease in NMDA receptor expression at an auditory synapse. *J. Neurosci.* 21,3342-3349, 2001.
9. Yamauchi, T., Hori T. & Takahashi T. Presynaptic inhibition by muscimol through GABA_B receptors. *Eur. J. Neurosci.* 12, 3433-3436, 2000.
10. Takahashi T., Hori T., Kajikawa Y.& Tsujimoto T. The role of GTP-binding protein activity in fast central synaptic transmission. *Science* 289, 460-463, 2000.
11. Okada M., Onodera K., Van Renterghem C., Sieghart W.& Takahashi T. Functional correlation of GABA_A receptor α subunits expression with the properties of IPSCs in the developing thalamus. *J. Neurosci.* 20, 2202-2208, 2000.
12. Iwasaki S., Momiyama A., Uchitel O.D.& Takahashi T. Developmental changes in calcium channel types mediating central synaptic transmission. *J. Neurosci.* 20, 59-65, 2000.
13. Hori T., Takai Y. & Takahashi T. Presynaptic mechanism for phorbol ester- induced synaptic potentiation. *J. Neurosci.* 19, 7262-7267, 1999.
14. Terada S., Tsujimoto T., Takei Y., Takahashi T. & Hirokawa N. Impairment of inhibitory synaptic transmission in mice lacking synapsin 1. *J. Cell Biol.* 145, 1039-1048, 1999.
15. Kobayashi K., Manabe T. & Takahashi T. Calcium-dependent mechanisms involved in presynaptic long-term depression at the hippocampal mossy fibre-CA3 synapse. *Eur. J. Neurosci.* 11, 1633-1638, 1999.
16. Mori H., Manabe T., Watanabe M., Satoh Y., Suzuki N., Toki S., Nakamura K., Yagi T., Kushiya E., Takahashi T., Inoue Y., Sakimura K. & Mishina M. Role of the carboxyl-terminal region of the GluR ϵ 2 subunit in synaptic localization of the NMDA receptor channel. *Neuron* 21, 571-580, 1998.
17. Manabe T., Noda Y., Mamiya T., Katagiri H., Houtani T., Nishi M., Noda T., Takahashi T., Sugimoto T., Nabeshima T. & Takeshima H. Facilitation of long-term potentiation and memory in mice lacking nociceptin receptors. *Nature* 394, 577-581, 1998.
18. Cuttle M. F, Tsujimoto T., Forsythe I.D. & Takahashi T. Facilitation of the presynaptic calcium current at an auditory synapse in rat brainstem. *J. Physiol.(London)* 512, 723-729, 1998.
19. Iwasaki S. & Takahashi T. Developmental changes in calcium channel types mediating synaptic transmission in rat auditory brainstem. *J. Physiol.(London)* 509, 419-423, 1998.
20. Takahashi T., Kajikawa Y. & Tsujimoto T. G-protein-coupled modulation of presynaptic calcium currents and transmitter release by a GABA_B receptor. *J. Neurosci.* 18, 3138-3146, 1998.
21. Forsythe I.D., Tsujimoto T., Barnes-Davies M., Cuttle M.F., & Takahashi T. Inactivation of presynaptic calcium current contribute to synaptic depression at a fast central synapse. *Neuron* 20, 797-807, 1998.
22. Takahashi T., Forsythe I., Tsujimoto T., Barnes-Davies M. & Onodera K. Presynaptic calcium current modulation by a metabotropic glutamate receptor. *Science* 274, 594- 597, 1996.
23. Kobayashi K., Manabe T. & Takahashi T. Presynaptic long-term depression at the hippocampal mossy fiber-CA3 synapse. *Science* 273, 648-650, 1996.
24. Yokoi M., Kobayashi K., Manabe T., Takahashi T., Sakaguchi I., Katsuura., Shigemoto R., Ohishi H., Nomura S., Nakamura K., Nakao K., Katsuki M., & Nakanishi S. Impairment of hippocampal mossy fiber LTD in mice lacking metabotropic glutamate receptor subtype 2. *Science* 273, 645-647, 1996.
25. Takahashi T., Feldmeyer D., Suzuki N., Onodera K., Cull-Candy S.G., Sakimura K., & Mishina M. Functional Correlation of NMDA receptor ϵ subunits expression with the properties of single-channel and synaptic current in the developing cerebellum. *J. Neurosci.* 16, 4376-4382, 1996.
26. Silver R.A., Cull-Candy S.G. & Takahashi T. Non-NMDA glutamate receptor occupancy and open probability at a rat cerebellar synapse with single and multiple release sites. *J. Physiol. (London)* 494, 231-250, 1996.
27. Kutsuwada T., Sakimura K., Manabe T., Takayama C., Katakura N., Kushiya E., Natsume R., Watanabe M., Inoue Y., Yagi T., Aizawa S., Arakawa M., Takahashi T., Nakamura Y., Mori H. & Mishina M. Impairment of suckling response, trigeminal neuronal pattern formation and hippocampal LTD in

- NMDA receptor $\epsilon 2$ subunit mutant mice. *Neuron* 16, 333-344, 1996.
28. Farrant M., Feldmeyer D., Takahashi T. & Cull-Candy S.G. NMDA-receptor channel diversity in the developing cerebellum. *Nature* 368, 335-339, 1994.
 29. Momiyama A. & Takahashi T. Calcium channels responsible for potassium-induced transmitter release at rat cerebellar synapses. *J Physiol. (London)* 476, 197-202, 1994.
 30. Takahashi T. & Momiyama A. Different types of calcium channels mediate central synaptic transmission. *Nature* 366, 156-158, 1993.

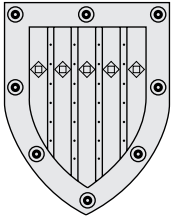

Department of Cellular and Molecular Pharmacology

Outline and Research Objectives

Our department was founded in 1885 as the first pharmacology department in Japan. It has had a strong research background in the field of calcium (Ca^{2+}) signalling since Professor Emeritus Setsuro Eabashi discovered in 1950's the regulatory role of intracellular Ca^{2+} concentration in muscle contraction. Since then the field of Ca^{2+} signalling research has expanded extensively: the Ca^{2+} signal is now known as a molecular switch in a vast array of important cell functions including muscle contraction, exocytosis, cell proliferation, immune responses and regulation of synaptic functions. The present research group led by Professor Iino is interested in the general principle of the Ca^{2+} signalling mechanism and is particularly interested in Ca^{2+} signalling in neurons and muscle cells at present. We have recently expanded the scope of our research to various signaling molecules upstream and downstream of Ca^{2+} signals. A notable feature of our department is that we have had an assembly of staff members with diverse backgrounds, e.g., cell physiology, molecular biology and neurobiology. We believe that the collaboration of these people will facilitate the elucidation of the medical and biological significance of Ca^{2+} signalling and related subjects.

Faculties and Students

Professor	Masamitsu Iino, M.D., Ph.D. (From April 1995)
Associate Professor	Kenzo Hirose, M.D., Ph.D.
Associate	2
Postdoctoral Fellows.....	3
Graduate Students	11
Research Students.....	3
Laboratory Staff.....	3

Past Research and Major Accomplishments

Our research focuses on the regulation of Ca^{2+} signals. In particular, we have made important contributions to clarifying intracellular Ca^{2+} release mechanisms. Our research also includes signaling molecules upstream and downstream of Ca^{2+} signals. Through these works, we have clarified feedback mechanisms that are essential to the generation of spatiotemporal patterns of Ca^{2+} signals.

1) Functional properties of IP_3R .

The receptor-mediated activation of phospholipase C results in the production of inositol 1,4,5-trisphosphate (IP_3), which then releases Ca^{2+} from the intracellular Ca^{2+} store. This Ca^{2+} mobilization is a central mechanism in the generation of Ca^{2+} signals for the regulation of various cell functions. We showed for the first time that the Ca^{2+} release via IP_3R is activated by submicromolar concentrations of Ca^{2+} (Fig. 1). We also discovered an inhibitory role of Ca^{2+} at higher concentrations. Thus, IP_3R activity is biphasically

dependent on cytosolic Ca^{2+} concentration with the maximum level of activation obtained at $0.3 \mu\text{M}$ (*J. Gen. Physiol.*, 1990). We also showed that the effects of Ca^{2+} on IP_3R activity have no notable delay in experiments using both caged IP_3 and caged Ca^{2+} (*Nature*, 1992). These results suggest the presence of a positive feedback loop in IP_3R -mediated Ca^{2+} release. Such a positive feedback loop is expected to have a major effect on Ca^{2+} release kinetics via IP_3R (*Nature*, 1994b). This notion, which is very popular in the field of Ca^{2+} signalling, now has a strong molecular basis as shown below.

We then studied the structure-function relationship of IP_3R . IP_3R consists of three subtypes ($\text{IP}_3\text{R}1$, $\text{IP}_3\text{R}2$ and $\text{IP}_3\text{R}3$), that are encoded by different genes and are expressed in a tissue- and development-specific manner. In collaboration with Prof. Kurosaki of Kansai Medical University, we genetically engineered DT40 B cells to express only one IP_3R subtype and

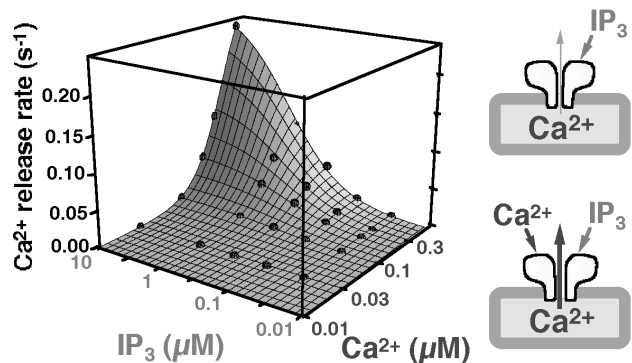

Figure 1. IP_3 and Ca^{2+} dependence of IP_3R activity. Both IP_3 and Ca^{2+} are required in the activation of IP_3R .

showed that each IP₃R subtype has distinct properties (*EMBO J.*, 1999). For example, the order of IP₃ sensitivity is IP₃R2 > IP₃R1 > IP₃R3. Furthermore, we succeeded in mapping the Ca²⁺ sensor region of IP₃R1 at glutamate 2100 (Fig. 2) (*EMBO J.*, 2001). Substitution of this amino acid by aspartate (E2100D) resulted in a 10-fold decrease in the Ca²⁺ sensitivity of IP₃R1. When we expressed the E2100D mutant IP₃R in DT40 cells, the rates of increase of Ca²⁺ concentration and Ca²⁺ oscillations during an agonist-induced response were significantly reduced compared with cells expressing wild-type IP₃R1 (Fig. 3). These results demonstrate that the Ca²⁺-mediated feedback regulation of IP₃R activity is extremely important for the generation of

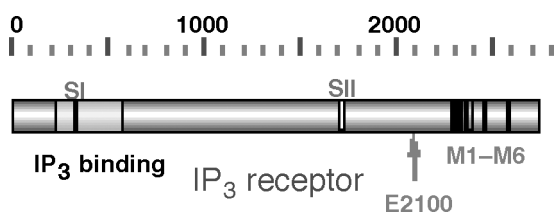

Figure 2. Ca²⁺ sensor of IP₃R. Glutamate (E) at position 2100 functions as the Ca²⁺ sensor of IP₃R.

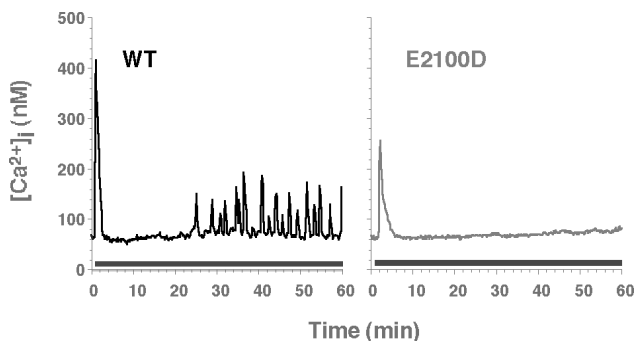

Figure 3. Ca²⁺ signalling in cells expressing mutant (E2100D) IP₃R with reduced Ca²⁺ sensitivity. BCR-mediated Ca²⁺ oscillation was abolished in cells expressing the mutant IP₃R.

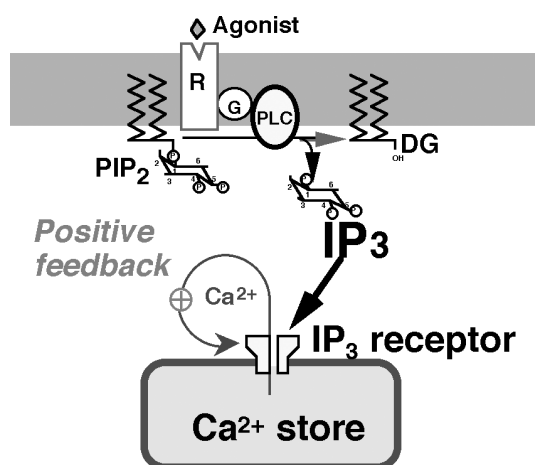

Figure 4. Positive feedback regulation of IP₃R via the Ca²⁺ sensor. Ca²⁺-sensor-mediated positive feedback regulation of Ca²⁺ release via IP₃R is essential for the spatio-temporal pattern generation of agonist-stimulated Ca²⁺ release.

spatiotemporal patterns of Ca²⁺ signals (Fig. 4).

2) Ca²⁺ imaging using intact tissues.

In order to fully understand the physiological functions of Ca²⁺-mediated cell signalling mechanisms, it is important to study Ca²⁺ signalling in cells that communicate with each other within intact tissues. With this notion in mind, we performed Ca²⁺ imaging experiments using intact vascular tissues. This method successfully revealed that vascular smooth muscle cells respond to sympathetic nerve stimuli with Ca²⁺ waves and oscillations (*EMBO J.*, 1994). To our surprise, resting arterial smooth muscle cells were not quiescent in terms of Ca²⁺ signals. We discovered spontaneous Ca²⁺ transients in unstimulated vascular smooth muscle cells (*J. Physiol.*, 1999). These Ca²⁺ transients are called “Ca²⁺ ripples” because their peak amplitudes were much smaller than those of sympathetic nerve-stimulated Ca²⁺ responses. Ca²⁺ ripples contribute to some extent to the resting tonus of the vascular wall. Other physiological functions await further clarification.

We have now extended the application of the tissue imaging method to intestinal tissues, and have for the first time succeeded in simultaneous imaging of Ca²⁺ signals in smooth muscle cells and interstitial cells of Cajal, which are the putative intestinal pacemaker cells (*J. Physiol.*, 2002). This method may help us elucidate the rhythm-making mechanism in intestinal tissues.

3) Excitation-contraction coupling and malignant hyperthermia.

In skeletal muscle cells depolarization of the plasma membrane induces Ca²⁺ release via the Ca²⁺ release channel (ryanodine receptor, RyR) on the adjacent sarcoplasmic reticulum. This process is called excitation-contraction (EC) coupling and has been studied using various methods. We have made several important contributions to clarifying the molecular basis of E-C coupling. There are three subtypes of RyR (RyR1, RyR2 and RyR3) encoded by different genes. First, we showed that RyR1 is critically important for EC coupling (*Nature*, 1994a). Second, we showed that RyR1 but not RyR2 or RyR3 supports the skeletal muscle EC coupling (*EMBO J.*, 1996). Third, a stretch of about 100 amino acids (D2 region), which is ~1,300 amino acids removed from the N terminus of RyR1, is important for EC coupling (*J. Biol. Chem.*, 1997). These results provided a framework for the molecular elucidation of EC coupling.

In relation to this subject, we have identified one of the genetic causes of malignant hyperthermia, a complication of general anesthesia with a life-threatening fever, resulting from an abnormality in the skeletal muscle calcium release channel, RyR1. We

identified a point mutation (L4838V) that is responsible for the gain-of-function mutation of RyR1 in malignant hyperthermia patients with marked clinical symptoms (*Jpn. J. Pharmacol.*, 2002).

We also discovered junctophilin, a protein that is responsible for the junction formation between the plasma membrane and the sarcoplasmic reticulum membrane (*Mol. Cell*, 2000).

4) *IP₃ imaging and discovery of a new IP₃ signalling mechanism.*

We have succeeded in visualizing the changes in intracellular IP₃ concentration using the translocation of the GFP-tagged PH domain of PLC- δ 1 (GFP-PHD) (*Science*, 1999). Using this method, we showed for the first time the dynamic changes in the intracellular IP₃ concentration (IP₃ oscillations and waves) (Fig. 5). These results show that the IP₃ dynamics is an important factor for the generation of dynamic spatiotemporal patterns of Ca²⁺ signals. Furthermore, we applied this method to measuring the changes in IP₃ concentration in cerebellar Purkinje cells and found a novel Ca²⁺-mediated IP₃ signalling pathway that leads to IP₃ production following climbing fiber inputs into Purkinje cells (*Neuron*, 2001) (Fig. 6).

Current Research

Based on the results of our studies of Ca²⁺ signalling, we recognize the importance of the spatiotemporal distribution of signalling molecules in defining cell signals. Thus, global Ca²⁺ waves and oscillations in smooth muscle cells result in *contraction* of the cells, while localized, transient rises at subplasmalemmal regions (Ca²⁺ sparks) result in *relaxation* of the cells. We, therefore, believe that it is extremely important to visualize the spatiotemporal distribution of signalling molecules within intact cells. To that end, we are currently engaged in the development of indicators of important signalling molecules (see below). Two types of excitable cells, neurons of the central nervous system and smooth muscle cells, are our current target cells. In particular, neurons have distinct cell polarity, therefore the spatiotemporal distribution of signalling molecules should be of great importance for the functions of neurons.

1) *Development of novel signal indicators.*

We are currently involved in the development of new genetically coded indicators of various important cell signals including nitric oxide (NO), protein phosphorylation and a Ca²⁺-dependent transcription factor. Some of the indicators are now being expressed in cells for analysis, and others are now close to application to cells.

2) *Ca²⁺ signalling in Purkinje cells and synaptic plasticity.*

Ca²⁺ and IP₃ dynamics in Purkinje cells are now studied in Purkinje cells in conjunction with the molecular basis of synaptic plasticity. We use both confocal and two-photon excitation microscopies to observe signals in individual dendrites.

3) *Molecular approaches to the study of IP₃R-mediated Ca²⁺ signalling.*

We have identified the Ca²⁺ sensor region of IP₃R and showed that a mutation at this site resulted in the inhibition of Ca²⁺ signals. We are introducing this mutation to various cells to inhibit Ca²⁺ signals. Through this approach it will be possible to clarify the roles of Ca²⁺ signals in various cells.

Future Prospects

1) *Elucidation of the relationship between Ca²⁺ signalling and cell functions.*

Intracellular Ca²⁺ signals exhibit extremely dynamic changes both temporally and spatially. Such property allows the Ca²⁺ signal to be an extremely versatile switch regulating diverse cell functions; from transmitter release in neurons to cell proliferation, and from muscle contraction to apoptosis. The role of Ca²⁺ signals in skeletal muscle contraction has been thoroughly clarified. However, there are still many cell functions in which Ca²⁺ signals are thought to play important regulatory roles, but their mechanisms remain elusive. We would like to elucidate the relationship between the Ca²⁺ signalling mechanism and the regulation of cell functions in all such frontiers.

2) *Visualization and analysis of molecular events at synapses during synaptic plasticity.*

Among many cell functions, we are particularly interested in those of neurons, which have such a unique cell polarity and provide an excellent platform for spatiotemporal cell signalling. We are interested in cell signals upstream and downstream of the Ca²⁺ signals. Combining new signal indicators and imaging methods, we wish to visualize the spatiotemporal distribution of cell signals in order to elucidate molecular events at the synapses during synaptic plasticity that underlies learning and memory.

Research Grants

1. Core Research for Evolutional Science and Technology (CREST) from Japan Science and Technology Cooperation "Calcium Signalling Research with Advancement of Imaging and

Molecular Genetic Methods" (Years 1996-2000)
¥676,312,000.

- Grant-in-Aid for Scientific Research (Specially Promoted Research) from the Ministry of Education, Science, Sports and Culture. "Visualization of Intracellular Signal Flow" (Years 2000-2004)
¥430,000,000.

Select Publications (Reprints of the ten references with asterisks are attached.)

- Iino, M. Tension responses of chemically skinned fibre bundles of the guinea-pig taenia caeci under varied ionic environments. *J. Physiol.* 320, 449-467, 1981.
- Iino, M. Calcium dependent inositol trisphosphate-induced calcium release in the guinea-pig taenia caeci. *Biochem. Biophys. Res. Commun.* 142, 47-52, 1987.
- Iino, M. Calcium induced calcium release mechanism in guinea-pig taenia caeci. *J. Gen. Physiol.* 94, 363-383, 1989.
- * Iino, M. Biphasic Ca^{2+} dependence of inositol 1,4,5-trisphosphate-induced Ca release in smooth muscle cells of the guinea pig taenia caeci. *J. Gen. Physiol.* 95, 1103-1122, 1990.
- Iino, M. Effects of adenine nucleotides on inositol 1,4,5-trisphosphate-induced calcium release in vascular smooth muscle cells. *J. Gen. Physiol.* 98, 681-698, 1991.
- * Iino, M. and Endo, M. Calcium-dependent immediate feedback control of inositol 1,4,5-trisphosphate-induced Ca^{2+} release. *Nature* 360, 76-78, 1992.
- Oyamada, H., Iino, M. and Endo, M. Effects of ryanodine on the properties of Ca^{2+} release from the sarcoplasmic reticulum in skinned skeletal muscle fibres of the frog. *J. Physiol.* 470, 335-3348, 1993.
- Iino, M., Yamazawa, T., Miyashita, Y., Endo, M. and Kasai, H. Critical intracellular Ca^{2+} concentration for all-or-none Ca^{2+} spiking in single smooth muscle cells. *EMBO J.* 12, 5287-5291., 1993
- Tsukioka, M., Iino, M. and Endo, M. pH dependence of inositol 1,4,5-trisphosphate-induced Ca^{2+} release in permeabilized smooth muscle cells of the guinea-pig. *J. Physiol.* 475, 369-375, 1994.
- Oyamada, H., Murayama, T., Takagi, T., Iino, M., Iwabe, N., Miyata, T. Ogawa, Y. and Endo, M. Primary structure and distribution of ryanodine-binding protein isoforms of the bullfrog skeletal muscle. *J. Biol. Chem.* 269, 17206-17214, 1994.
- Kasai, Y., Iino, M., Tsutsumi, O., Taketani, Y. and Endo, M. Effects of cyclopiazonic acid on rhythmic contractions in uterine smooth muscle bundles of the rat. *Br. J. Pharmacol.* 112, 1132-11136, 1994.
- * Takeshima, H., Iino, M., Takekura, H., Nishi, M., Kuno, J., Minowa, O., Takano, H. and Noda, T. Excitation-contraction uncoupling and muscular degeneration in mice lacking functional skeletal muscle ryanodine-receptor gene. *Nature* 369, 556-559, 1994.
- * Iino, M., Kasai, H. and Yamazawa, T. Visualization of neural control of intracellular Ca^{2+} concentration in single vascular smooth muscle cells in situ. *EMBO J.* 13, 5026-5031, 1994.
- * Hirose, K. and Iino, M. Heterogeneity of channel density in inositol-1,4,5-trisphosphate- sensitive Ca^{2+} stores. *Nature* 372, 791-794, 1994.
- Kasai, Y., Tsutsumi, O., Taketani, Y., Endo, M. and Iino, M. Stretch-induced enhancement of contractions in uterine smooth muscle of rats. *J. Physiol.* 486, 373-384, 1995
- Takeshima, H., Yamazawa, T., Ikemoto, T., Takekura, H., Nishi, M., Noda, T. and Iino, M. Ca^{2+} -induced Ca^{2+} release in myocytes from dyspedic mice lacking type-1 ryanodine receptor. *EMBO J.* 14, 2999-3006, 1995.
- Ikemoto, T., Iino, M. and Endo, M. Enhancing effect of calmodulin on Ca^{2+} -induced Ca^{2+} release in the sarcoplasmic reticulum of rabbit skeletal muscle fibres. *J. Physiol.* 487, 573-582, 1995.
- Ikemoto, T., Iino, M. and Endo, M. Effect of calmodulin antagonists on calmodulin-induced biphasic modulation of Ca^{2+} -induced Ca^{2+} release. *Br. J. Pharmacol.* 118, 690-694, 1996.
- Takeshima, H., Ikemoto, T., Nishi, M., Nishiyama, N., Shimuta, M., Sugitani, Y., Kuno, J., Saito, I., Saito, H., Endo, M., Iino, M. and Noda, M. Generation and characterization of mutant mice lacking ryanodine receptor type 3. *J. Biol. Chem.* 271, 19649-19652, 1996.
- * Yamazawa, T., Takeshima, H., Sakurai, T., Endo, M. and Iino, M. Subtype specificity of ryanodine receptor for Ca^{2+} signal amplification in excitation-contraction coupling. *EMBO J.* 15, 6172-6177, 1996.
- Yamazawa, T., Takeshima, H., Shimuta, M. and Iino, M. A region of the ryanodine receptor critical for excitation-contraction coupling in skeletal muscle. *J. Biol. Chem.* 272, 8161-8164, 1997.
- Ikemoto, T., Komazaki, S., Takeshima, H., Nishi, M., Noda, T., Iino, M. and Endo, M. Functional and morphological features of skeletal muscle from mutant mice lacking both type 1 and type 3 ryanodine receptors. *J. Physiol.* 501, 305-312, 1997.
- Kasai, Y., Yamazawa, T., Sakurai, T., Taketani, Y. and Iino, M. Endothelium-dependent frequency modulation of Ca^{2+} signaling in individual vascular smooth muscle cells of the rat. *J. Physiol.* 504, 349-357, 1997.
- Takesako, K., Sasamoto, K., Ohkura, Y., Hirose, K. and Iino, M. Low-affinity fluorescent indicator for intracellular calcium ions. *Anal. Commun.* 34, 391-392, 1997.
- Hirose, K., Kadowaki, S. and Iino, M. Allosteric regulation by cytoplasmic Ca^{2+} and IP_3 of the gating of IP_3 receptors in guinea pig vascular smooth muscle cells. *J. Physiol.* 506, 407-414, 1998.
- Takeshima, H., Komazaki, S., Hirose, K., Nishi, M., Noda, T. and Iino, M. Embryonic lethality and abnormal cardiac myocytes in mice lacking ryanodine receptor type 2. *EMBO J.* 17, 3309-3316, 1998.

27. Takeshima, H., Shimuta, M., Komazaki, S., Ohmi, K., Nishi, M., Iino, M., Miyata, A. and Kangawa, K. Mitsugumin29, a novel synaptophysin family member from the triad junction in skeletal muscle. *Biochem. J.* 331, 317-322, 1998.
28. Okada, H., Bolland, S., Hashimoto, A., Kurosaki, M., Kabuyama, Y., Iino, M., Ravech, J.V., Kurosaki, T. Role of the inositol phosphatase SHIP in B cell receptor-induced Ca^{2+} oscillatory response. *J. Immunol.* 161, 5129-5132, 1998.
29. Ikemoto, T., Takeshima, H., Iino, M. and Endo, M. Effect of calmodulin on Ca^{2+} -induced Ca^{2+} release of skeletal muscle from mutant mice expressing either ryanodine receptor type 1 or type 3. *Pflügers Arch.* 437, 43-48, 1998.
30. Manabe, T., Noda, Y., Mamiya, T., Katagiri, H., Houtani, T., Nishi, M., Noda, T., Takahashi, T., Sugimoto, T., Nabeshima, T. and Takeshima, H. Facilitation of long-term potentiation and memory in mice lacking nociceptin receptor. *Nature* 394, 577-581, 1998.
31. Hirabayashi, T., Kume, K., Hirose, K., Yokomizo, T., Iino, M., Itoh, H. and Shimizu, T. Critical duration of intracellular Ca^{2+} response required for continuous translocation and activation of cytosolic phospholipase A_2 . *J. Biol. Chem.* 274, 5163-5169, 1999.
- 32.* Miyakawa, T., Maeda, A., Yamazawa, T., Hirose, K., Kurosaki, T. and Iino, M. Encoding of Ca^{2+} signals by differential expression of IP_3 receptor subtypes. *EMBO J.* 18, 1303-1308, 1999.
33. Hashimoto, A., Hirose, K., Okada, H., Kurosaki, T. and Iino, M. Inhibitory modulation of B cell receptor-mediated Ca^{2+} mobilization by SH2 domain containing inositol 5'-phosphatase (SHIP). *J. Biol. Chem.* 274, 11203-11208, 1999.
34. Hirose, K., Takeshima, H. and Iino, M. Fluorescent indicators for inositol 1,4,5-triphosphate based on bioconjugates of pleckstrin homology domain and fluorescent dyes. *Anal. Commun.* 36, 175-177, 1999.
- 35.* Hirose, K., Kadowaki, S., Tanabe, M., Takeshima, H. and Iino, M. Spatio-temporal dynamics of inositol 1,4,5-triphosphate that underlies complex Ca^{2+} mobilization patterns. *Science* 284, 1527-1530, 1999.
36. Asada, Y., Yamazawa, T., Hirose, K., Takasaka, T. and Iino, M. Dynamic signaling in rat arterial smooth muscle cells under the control of local renin-angiotensin system. *J. Physiol.* 521, 497-505, 1999.
37. Nishi, M., Komazaki, S., X Kurebayashi, N., Ogawa, Y., Noda, T., Iino, M. and Takeshima, H. Abnormal features in skeletal muscle from mice lacking Mitsugumin29. *J. Cell Biol.* 147, 1473-1480, 1999.
38. Takeshima, H., Komazaki, S., Nishi, M., Iino, M. and Kangawa, K. Junctophilins: a novel family of junctional membrane complex proteins. *Molecular Cell.* 6, 11-22, 2000.
39. Hashimoto, A., Hirose, K., Kurosaki, T. and Iino, M. Negative control of store-operated Ca^{2+} influx by B cell receptor crosslinking. *J. Immunol.* 166, 1003-1008, 2001.
40. Nemoto, T., Kimura, R., Ito, K., Tachikawa, A., Miyashita, Y., Iino, M. and Kasai, H. Sequential-replenishment mechanism of exocytosis in pancreatic acini. *Nature Cell Biol.* 3, 253-258, 2001.
41. Inoue, T., Kikuchi, K., Hirose, K., Iino, M. and Nagano, T. Small molecule-based laser inactivation of inositol 1,4,5-trisphosphate receptor. *Chem. Biol.* 8, 9-15, 2001.
- 42.* Miyakawa, T., Mizushima, A., Hirose, K., Yamazawa, T., Bezprozvanny, I., Kurosaki, T. and Iino, M. Ca^{2+} -sensor region of IP_3 receptor controls intracellular Ca^{2+} signalling. *EMBO J.* 20, 1674-1680, 2001.
43. Fujiwara, A., Hirose, K., Yamazawa, T. and Iino, M. Reduced IP_3 sensitivity of IP_3 receptor in Purkinje neurons. *NeuroReport* 12, 2647-2651 2001.
- 44.* Okubo, Y., Kakizawa, S., Hirose, K. and Iino, M. Visualization of IP_3 dynamics reveals a novel AMPA receptor-triggered IP_3 production pathway mediated by voltage-dependent Ca^{2+} influx in Purkinje cells. *Neuron* 32, 113-122, 2001.
45. Namikis, S., Hirose, K. and Iino, M. Mapping of heme-binding domains in soluble guanylyl cyclase $\beta 1$ subunit. *Biochem. Biophys. Res. Commun.* 288, 798-804, 2001.
46. Matsuzaki, M., Ellis-Davies, G.C.R., Nemoto, T., Miyashita, Y., Iino, M. and Kasai, H. Dendritic spine geometry is critical for AMPA receptor expression in hippocampal CA1 pyramidal neurons. *Nature Neurosci.* 4, 1086-1092, 2001.
47. Yamazawa, T. and Iino, M. Simultaneous imaging of Ca^{2+} signals in interstitial cells of Cajal and longitudinal smooth muscle cells during rhythmic activity in mouse ileum. *J. Physiol.* 538, 823-835, 2002.
48. Oyamada, H., Oguchi, K., Saitoh, N., Yamazawa, T., Hirose, K., Kawana, Y., Wakatsuki, K., Oguchi, K., Tagami, M., Hanaoka, K., Endo, M. and Iino, M. Novel mutations in C-terminal channel region of the ryanodine receptor in malignant hyperthermia patients. *Jpn. J. Pharmacol.* 88, 159-166, 2002.
49. Tu, H., Miyakawa, T., Wang, Z., Glouchankova, L., Iino, M. and Bezprozvanny, I. Functional characterization of the type 1 inositol 1,4,5-trisphosphate receptor coupling domain SII([+/-]) splice variants and the opisthotonos mutant form. *Biophys. J.* 82, 1995-2004, 2002.
50. Ueda, H.R., Chen, W., Adachi, A., Wakamatsu, H., Hayashi, S., Takasugi, T., Nagano, M., Nakahama, K.-I., Suzuki, Y., Sugano, S., Iino, M., Shigeyoshi, Y. and Hashimoto, S. A transcription factor response element for gene expression during circadian night. *Nature*, 418, 534-539, 2002.

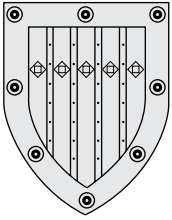

Department of Molecular Neurobiology

Outline and Research Objective

We have been investigating the molecular mechanism of brain functions. Current research activities are focused on the glutamate receptor (GluR) and learning and memory. We elucidated the molecular diversity of the *N*-methyl-D-aspartate (NMDA)-type GluR and discovered the novel δ subfamily of GluR by molecular cloning. Roles of these GluRs in brain functions have been studied by gene targeting.

Faculties and Students

Professor and Chair	Masayoshi Mishina, Ph.D (1994~)
Lecturer	Hisashi Mori, Ph.D
Associate	2 (Naoto Matsuda, M.D and Tomonori Takeuchi, Ph.D)
Postdoctoral Fellow	2
Graduate Student.....	11
Research Student	2
Secretary	2

Past Research and Major Accomplishments

The NMDA subtype of GluR is unique in functional properties among many neurotransmitter receptors and ion channels mediating neural signaling in the brain. The NMDA receptor channel is gated both by ligands and by voltage, and is highly permeable to Ca^{2+} . These characteristics of the NMDA receptor directly relate to its important physiological roles in synaptic plasticity as a molecular coincidence detector. Some forms of long-term potentiation (LTP) and long-term depression (LTD), which are thought to underlie learning and memory, are critically dependent on the NMDA receptor channel.

Molecular characterization of the NMDA receptor

We elucidated the molecular diversity of the NMDA receptor by molecular cloning. Highly active NMDA receptor channel was formed *in vitro* by co-expression of two members of GluR subunit families, that is, the GluR ϵ (NR2) and GluR ζ (NR1). There are four members in the ϵ subunit family, whereas only one member is known in the GluR ζ subunit family except for the splice variants. All of the NMDA receptor channel subunits possess asparagine in segment M2. Replacement by glutamine of the asparagine in segment M2 of the GluR ϵ 2 and GluR ζ 1 strongly reduced the sensitivity to Mg^{2+} block of the NMDA receptor channel. Since there is strong evidence that Mg^{2+} produces a voltage-dependent block of the channel by binding a site deep within the ionophore, these

results are consistent with the view that segment M2 constitutes the ion channel pore of the NMDA receptor channel.

At the embryonic stages, the GluR ϵ 2 (NR2B) subunit mRNA is expressed in the entire brain, and the GluR ϵ 4 (NR2D) subunit mRNA in the diencephalon and the brainstem. After birth, the GluR ϵ 1 (NR2A) subunit mRNA appears in the entire brain, and the GluR ϵ 3 (NR2C) subunit mRNA mainly in the cerebellum. The expression of the GluR ϵ 2 subunit mRNA becomes restricted to the forebrain, and that of the GluR ϵ 4 subunit mRNA is strongly reduced. The GluR ζ 1 subunit mRNA is found ubiquitously in the brain during development. The four GluR ϵ subunits are also distinct in functional properties and regulation. Thus, multiple GluR ϵ subunits are major determinants of the NMDA receptor channel diversity, and the molecular compositions and functional properties of NMDA receptor channels are different depending on the brain regions and developmental stages. These findings raise an important question whether the molecular diversity underlies the various physiological roles of the NMDA receptor channel.

Physiological roles of multiple NMDA receptor subtypes

To examine the functional roles *in vivo* of the diverse NMDA receptor subtypes, we generated mutant mice defective in respective GluR ϵ subunits by gene targeting. Disruption of the GluR ϵ 1 gene results in reduction of hippocampal LTP and impairment of Morris water maze learning. In GluR ϵ 1 mutant mice, thresholds for both hippocampal LTP and contextual learning increased. The ablation of the GluR ϵ 2 subunit also impaired synaptic plasticity in the hippocampus. The reduction of GluR ϵ 1 and GluR ϵ 2 affected the plasticity of the hippocampal CA3 region in a synapse-specific manner. These results indicate that the NMDA receptor GluR ϵ 1 and GluR ϵ 2 subtypes play a key role in synaptic plasticity, learning and memory.

GluR ϵ 2 mutant mice died shortly after birth and failed to form the whisker-related neural pattern (bar-

relettes) in the brainstem trigeminal complex. In contrast, the barrelette formation was normal in GluR4 mutant mice. These results show the involvement of the GluR2 subunit in the refinement of the synapse formation of periphery-related neural patterns in the mammalian brain. Heterozygous mutant mice with reduced GluR2 subunit of the NMDA receptor showed strongly enhanced startle responses to acoustic stimuli. On the other hand, heterozygous and homozygous mutation of the other NMDA receptor GluR subunits exerted little or only small effects on acoustic startle responses. Thus, the NMDA receptor GluR2 plays a role in the regulation of the startle reflex. GluR4 mutant mice exhibited reduced spontaneous activity, while GluR3 mutant mice showed little obvious deficit. GluR1 and GluR4 differentially contributed to pain modulation.

Discovery and functional roles of GluR δ 2 in the cerebellum

The wealth of knowledge on the neural circuits in the cerebellum makes the cerebellum an ideal system to study the molecular mechanism of brain function. By molecular cloning, we found a novel GluR subfamily named GluR δ . GluR δ 2 was selectively localized in cerebellar Purkinje cells. Furthermore, its intracellular localization was restricted to the parallel fiber-Purkinje cell synapses. The carboxyl terminus of GluR δ 2 interacted with delphilin containing a single PDZ domain, formin homology (FH) domains and a coiled-coil structure. Analyses of GluR δ 2 mutant mice revealed that the GluR δ 2 subunit was essential in motor coordination and cerebellar LTD and in refinement and maintenance of Purkinje cell synapses.

We investigated eyeblink conditioning in GluR δ 2 mutant mice to elucidate its cerebellar cortical neural mechanism, with reference to the temporal relationship of conditioned and unconditioned stimuli. In the delay paradigm, in which a tone (CS) overlapped temporally with a periorbital shock (US), GluR δ 2 mutant mice exhibited a severe impairment in learning. However, in the trace paradigm in which a stimulus-free trace interval up to 500 ms intervened between the CS and US, GluR δ 2 mutant mice learned as successfully as the wild-type mice even with 0 ms-trace interval. We then examined the delay and trace eyeblink conditioning in NMDA receptor GluR1 mutant mice. In delay conditioning, GluR1 mutant mice attained a normal level of the conditioned response (CR), although acquisition was a little slower than in wild-type mice. In contrast, GluR1 mutant mice exhibited severe impairment of the attained level of the CR and disturbed temporal pattern of CR expression in trace conditioning with a longer trace interval of 500 ms. These results suggest that neural substrates underlying eyeblink conditioning are different

depending on the temporal overlap of the conditioned and unconditioned stimuli.

Current Research

These studies show that GluRs play key roles in memory acquisition and neural pattern formation. The memory signaling in the adult brain may share the common molecular mechanism with the activity-dependent synapse refinement during neural development. To further investigate the molecular basis of higher brain function, we are developing the conditional gene targeting in the C57BL/6 mouse genetic background and the molecular genetics of zebrafish.

Conditional gene targeting in C57BL/6 genetic background

We developed an efficient homologous recombination system using ES cells derived from C57BL/6 strain. For a cell type-specific and temporal regulation of gene targeting in the brain, we have generated mouse lines that express Cre recombinase-progesterone receptor fusion (CrePR) gene specifically cerebellar granule cells, cerebellar Purkinje cells, hippocampal CA3 pyramidal neurons and striatal spiny neurons. Crossing of target mice first with FLP mice to remove the *neo* selection marker gene and then with Cre mice has yielded mutant mice lacking GluR genes in specific neurons.

Molecular genetics of zebrafish

Elucidation of how the neural network is formed and modulated is essential to understand how the brain is functioning. The retinotectal projection and olfactory systems in transparent zebrafish are suitable to analyze synapse formation *in vivo*. We are developing a novel strategy that visualizes and manipulates developing neurons *in vivo*.

Future Prospects

Combination of molecular genetic approaches in mice and zebrafish will facilitate our understanding of the mechanism of higher brain function at the molecular, cellular and neural network levels.

Research Grants

1. Grant-in-Aid for Scientific Research on Priority Areas, The Ministry of Education, Culture, Sports, Science and Technology (1995-1999)
2. Grant-in-Aid for Scientific Research (A), The Ministry of Education, Culture, Sports, Science and Technology (1996-1998)
3. CREST, Japan Science and Technology Corporation (1996-2001)

4. Grant-in-Aid for Scientific Research on Priority Areas, The Ministry of Education, Culture, Sports, Science and Technology (2000-)
5. SORST, Japan Science and Technology Corporation (2002-)

Select Publications

1. Mishina, M., Kurosaki, T., Tobimatsu, T., Morimoto, Y., Noda, M., Yamamoto, T., Terao, M., Lindstrom, J., Takahashi, T., Kuno, M. and Numa, S. Expression of functional acetylcholine receptor from cloned cDNAs. *Nature* 307, 604-608, 1984.
2. Mishina, M., Tobimatsu, T., Imoto, K., Tanaka, K., Fujita, Y., Fukuda, K., Kurasaki, M., Takahashi, H., Morimoto, Y., Hirose, T., Inayama, S., Takahashi, T., Kuno, M. and Numa, S. Location of functional regions of acetylcholine receptor α -subunit by site-directed mutagenesis. *Nature* 313, 364-369, 1985.
3. Takai, T., Noda, M., Mishina, M., Shimizu, S., Furutani, Y., Kayano, T., Ikeda, T., Kubo, T., Takahashi, H., Takahashi, T., Kuno, M. and Numa, S. Cloning, sequencing and expression of cDNA for a novel subunit of acetylcholine receptor from calf muscle. *Nature* 315, 761-764, 1985.
4. Sakmann, B., Methfessel, C., Mishina, M., Takahashi, T., Takai, T., Kurasaki, M., Fukuda, K. and Numa, S. Role of acetylcholine receptor subunits in gating of the channel. *Nature* 318, 538-543, 1985.
5. Mishina, M., Takai, T., Imoto, K., Noda, M., Takahashi, T., Numa, S., Methfessel, C. and Sakmann, B. Molecular distinction between fetal and adult forms of muscle acetylcholine receptor. *Nature* 321, 406-411, 1986.
6. Kubo, T., Fukuda, K., Mikami, A., Maeda, A., Takahashi, H., Mishina, M., Haga, T., Haga, K., Ichiyama, A., Kangawa, K., Kojima, M., Matsuo, H., Hirose, T. and Numa, S. Cloning, sequencing and expression of complementary DNA encoding the muscarinic acetylcholine receptor. *Nature* 323, 411-416, 1986.
7. Imoto, K., Methfessel, C., Sakmann, B., Mishina, M., Mori, Y., Konno, T., Fukuda, K., Kurasaki, M., Bujo, H., Fujita, Y. and Numa, S. Location of a δ -subunit region determining ion transport through the acetylcholine receptor channel. *Nature* 324, 670-674, 1986.
8. Fukuda, K., Kubo, T., Akiba, I., Maeda, A., Mishina, M. and Numa, S. Molecular distinction between muscarinic acetylcholine receptor subtypes. *Nature* 327, 623-625, 1987.
9. Fukuda, K., Higashida, H., Kubo, T., Maeda, A., Akiba, I., Bujo, H., Mishina, M. and Numa, S. Selective coupling with K^+ currents of muscarinic acetylcholine receptor subtypes in NG108-15 cells. *Nature* 335, 355-358, 1988.
10. Imoto, K., Busch, C., Sakmann, B., Mishina, M., Konno, T., Nakai, J., Bujo, H., Mori, Y., Fukuda, K. and Numa, S. Rings of negatively-charged amino acids determine the acetylcholine receptor channel conductance. *Nature* 335, 645-648, 1988.
11. Meguro, H., Mori, H., Araki, K., Kushiya, E., Kutsuwada, T., Yamazaki, M., Kumanishi, T., Arakawa, M., Sakimura, K. and Mishina, M. Functional characterization of a heteromeric NMDA receptor channel expressed from cloned cDNAs. *Nature* 357, 70-74, 1992.
12. Kutsuwada, T., Kashiwabuchi, N., Mori, H., Sakimura, K., Kushiya, E., Araki, K., Meguro, H., Masaki, H., Kumanishi, T., Arakawa, M. and Mishina, M. Molecular diversity of the NMDA receptor channel. *Nature* 358, 36-41, 1992.
13. Mori, H., Masaki, H., Yamakura, T. and Mishina, M. Identification by mutagenesis of a Mg^{2+} block site of the NMDA receptor channel. *Nature* 358, 673-675, 1992.
14. akimura, K., Kutsuwada, T., Ito, I., Manabe, T., Takayama, C., Kushiya, E., Yagi, T., Aizawa, S., Inoue, Y., Sugiyama, H. and Mishina, M. Reduced hippocampal LTP and spatial learning in mice lacking NMDA receptor $\epsilon 1$ subunit. *Nature* 373, 151-155, 1995.
15. Kashiwabuchi, N., Ikeda, K., Araki, K., Hirano, T., Shibuki, K., Takayama, C., Inoue, Y., Kutsuwada, T., Yagi, T., Kang, Y., Aizawa, S. and Mishina, M. Impairment of motor coordination, Purkinje cell synapse formation and cerebellar long-term depression in *GluR $\delta 2$* mutant mice. *Cell* 81, 245-252, 1995.
16. Kutsuwada, T., Sakimura, K., Manabe, T., Takayama, C., Katakura, N., Kushiya, E., Natsume, R., Watanabe, M., Inoue, Y., Yagi, T., Aizawa, S., Arakawa, M., Takahashi, T., Nakamura, Y., Mori, H. and Mishina, M. Impairment of suckling response, trigeminal neuronal pattern formation and hippocampal LTD in NMDA receptor $\epsilon 2$ subunit mutant mice. *Neuron* 16, 333-344, 1996.
17. Takahashi, T., Feldmeyer, D., Suzuki, N., Onodera, K., Cull-Candy, S. G., Sakimura, K. and Mishina, M. Functional correlation of NMDA receptor ϵ subunits expression with the properties of single-channel and synaptic currents in the developing cerebellum. *J. Neurosci.* 16, 4376-4382, 1996.
18. Ito, I., Futai, K., Katagiri, H., Watanabe, M., Sakimura, K., Mishina, M. and Sugiyama, H. Synapse-selective impairment of NMDA receptor functions in mice lacking NMDA receptor $\epsilon 1$ or $\epsilon 2$ subunit. *J. Physiol.* 500, 401-408, 1997.
19. Taniguchi, M., Yuasa, S., Fujisawa, H., Naruse, I., Saga, S., Mishina, M. and Yagi, T. Disruption of semaphorin III/D gene causes severe abnormality in peripheral nerve projection. *Neuron* 19, 519-530, 1997.
20. Kurihara, H., Hashimoto, K., Kano, M., Takayama, C., Sakimura, K., Mishina, M., Inoue, Y. and Watanabe, M. Impaired parallel fiber-Purkinje cell synapse stabilization during cerebellar development of mutant mice lacking the glutamate receptor $\delta 2$ subunit. *J. Neurosci.* 17, 9613-9623, 1997.
21. Watanabe, M., Fukaya, M., Sakimura, K., Manabe, T., Mishina, M. and Inoue, Y. Selective scarcity of NMDA receptor channel subunits in the stratum

- lucidum (mossy fiber-recipient layer) of the hippocampal CA3 subfield. *Eur. J. Neurosci.* 10, 478-487, 1998.
22. Ando, H. and Mishina, M. Efficient mutagenesis of zebrafish by a DNA cross-linking agent. *Neurosci. Lett.* 244, 81-84, 1998.
 23. Kohmura, N., Senzaki, K., Hamada, S., Kai, N., Yasuda, R., Watanabe, M., Ishii, H., Yasuda, M., Mishina, M. and Yagi, K. Diversity revealed by a novel family of cadherins expressed in neurons at synaptic complex. *Neuron* 20, 1137-1151, 1998.
 24. Kiyama, Y., Manabe, T., Sakimura, K., Kawakami, F., Mori, H. and Mishina, M. Increased thresholds for long-term potentiation and contextual learning in mice lacking the NMDA-type glutamate receptor $\epsilon 1$ subunit. *J. Neurosci.* 18, 6704-6712, 1998.
 25. Mori, H., Manabe, T., Watanabe, M., Satoh, Y., Suzuki, N., Toki, S., Nakamura, K., Yagi, T., Kushiya, E., Takahashi, T., Inoue, Y., Sakimura, K. and Mishina, M. Role of the carboxyl-terminal region of the GluR $\epsilon 2$ subunit in synaptic localization of the NMDA receptor channel. *Neuron* 21, 571-580, 1998.
 26. Morikawa, E., Mori, H., Kiyama, Y., Mishina, M., Asano, T. and Kirino, T. Attenuation of focal ischemic brain injury in mice deficient in the $\epsilon 1$ (NR2A) subunit of NMDA receptor. *J. Neurosci.* 18, 9727-9732, 1998.
 27. Hayashi, T., Umemori, H., Mishina, M. and Yamamoto, T. The AMPA receptor interacts with and signals through the protein tyrosine kinase Lyn. *Nature* 397, 72-76, 1999.
 28. Furuyashiki, T., Fujisawa, K., Fujita, A., Madaule, P., Uchino, S., Mishina, M., Bito, H. and Narumiya, S. Citron, a Rho-target, interacts with PSD-95/SAP-90 at glutamatergic synapses in the thalamus. *J. Neurosci.* 19, 109-118, 1999.
 29. Tsujita, M., Mori, H., Watanabe, M., Suzuki, M., Miyazaki, J. and Mishina, M. Cerebellar granule cell-specific and inducible expression of Cre recombinase in the mouse. *J. Neurosci.* 19, 10318-10323, 1999.
 30. Minami, T., Okuda-Ashitaka, E., Mori, H., Sakimura, K., Watanabe, M., Mishina, M. and Ito, S. Characterization of nociceptin/orphanin FG-induced pain responses in conscious mice: Neonatal capsaicin treatment and *N*-methyl-D-aspartate receptor GluR ϵ subunit knockout mice. *Neuroscience* 97, 133-142, 2000.
 31. Hironaka, K., Umemori, H., Tezuka, T., Mishina, M. and Yamamoto, T. The protein-tyrosine phosphatase PTPMEG interacts with glutamate receptor $\delta 2$ and ϵ subunits. *J. Biol. Chem.* 275, 16167-16173, 2000.
 32. Matsuda, I. and Mishina, M. Identification of a juxtamembrane segment of the glutamate receptor $\delta 2$ subunit required for the plasma membrane localization. *Biochem. Biophys. Res. Commun.* 275, 565-571, 2000.
 33. Nakamura, K., Manabe, T., Watanabe, M., Mamiya, T., Ichikawa, R., Kiyama, Y., Sanbo, M., Yagi, T., Inoue, Y., Nabeshima, T., Mori, H. and Mishina, M. Enhancement of hippocampal LTP, reference memory and sensorimotor gating in mutant mice lacking a telencephalon-specific cell adhesion molecule. *Eur. J. Neurosci.* 13, 179-189, 2001.
 34. Nakazawa, T., Komai, S., Tezuka, T., Hisatsune, C., Umemori, H., Semba, K., Mishina, M., Manabe, T. and Yamamoto, T. Characterization of Fyn-mediated tyrosine phosphorylation sites on GluR $\epsilon 2$ (NR2B) subunit of the *N*-methyl-D-aspartate receptor. *J. Biol. Chem.* 276, 693-699, 2001.
 35. Miyamoto, Y., Yamada, K., Noda, Y., Mori, H., Mishina, M. and Nabeshima, T. Hyperfunction of dopaminergic and serotonergic neural systems in mice lacking NMDA receptor $\epsilon 1$ subunit. *J. Neurosci.* 21, 750-757, 2001.
 36. Uchino, S., Nakamura, T., Nakamura, K., Nakajima-Iijima, S., Mishina, M., Kohsaka, S. and Kudo, Y. Real-time two-dimensional visualization of ischemia-induced glutamate release from hippocampal slices. *Eur. J. Neurosci.* 13, 670-678, 2001.
 37. Kishimoto, Y., Kawahara, S., Mori, H., Mishina, M. and Kirino, Y. Long-trace interval eyeblink conditioning is impaired in mutant mice lacking the NMDA receptor subunit $\epsilon 1$. *Eur. J. Neurosci.* 13, 1221-1227, 2001.
 38. Kishimoto, Y., Kawahara, S., Suzuki, M., Mori, H., Mishina, M. and Kirino, Y. Classical eyeblink conditioning in glutamate receptor subunit $\delta 2$ mutant mice is impaired in the delay paradigm but not in the trace paradigm. *Eur. J. Neurosci.* 13, 1249-1253, 2001.
 39. Kitayama, K., Abe, M., Kakizaki, T., Honma, D., Natsume, R., Fukaya, M., Watanabe, M., Miyazaki, J., Mishina, M. and Sakimura, K. Purkinje cell-specific and inducible gene recombination system generated from C57BL/6 mouse ES cells. *Biochem. Biophys. Res. Commun.* 281, 1134-1140, 2001.
 40. Takeuchi, T., Kiyama, Y., Nakamura, K., Tsujita, M., Matsuda, I., Mori, H., Munemoto, Y., Kuriyama, H., Natsume, R., Sakimura, K. and Mishina, M. Roles of the glutamate receptor $\epsilon 2$ and $\delta 2$ subunits in the potentiation and prepulse inhibition of the acoustic startle reflex. *Eur. J. Neurosci.* 14, 153-160, 2001.
 41. Wainai, T., Takeuchi, T., Seo, N. and Mishina, M. Regulation of acute nociceptive responses by the NMDA receptor GluR $\epsilon 2$ subunit. *Neuroreport* 12, 3165-3172, 2001.
 42. Kishimoto, Y., Kawahara, S., Fujimichi, R., Mori, H., Mishina, M., and Kirino, Y. Impairment of eyeblink conditioning in GluR $\delta 2$ mutant mice depends on the temporal overlap between conditioned and unconditioned stimuli. *Eur. J. Neurosci.* 14, 1515-1521, 2001.
 43. Hashimoto, K., Ichikawa, R., Takeuchi, H., Inoue, Y., Aiba, A., Sakimura, K., Mishina, M., Hashikawa, T., Konnerth, A., Watanabe, M., and Kano, M. Roles of GluR $\delta 2$ and mGluR1 in climbing fiber synapse elimination during postnatal cerebellar development. *J. Neurosci.* 21, 9701-9712, 2001.
 44. Takatsuki, K., Kawahara, S., Mori, H., Mishina, M. and Kirino, Y. Scopolamine impairs eyeblink condi-

- tioning in the cerebellar LTD-deficient mice. *Neuroreport* 13, 159-162, 2002.
45. Miyagi, Y., Yamashita, T., Fukaya, M., Sonoda, T., Okuno, T., Yamada, K., Watanabe, M., Nagashima, Y., Aoki, I., Okuda, K., Mishina, M. and Kawamoto, S. Delphilin: a novel PDZ- and formin homology-domain containing protein, which synaptically localizes and interacts with glutamate receptor $\delta 2$ subunit. *J. Neurosci.* 22, 803-814, 2002.
 46. Miyamoto, Y., Yamada, K., Noda, Y., Mori, H., Mishina, M. and Nabeshima, T. Lower sensitivity to stress and altered monoaminergic neuronal function in mice lacking the NMDA receptor $\epsilon 4$ subunit. *J. Neurosci.* 22, 2335-2342, 2002.
 47. Takeuchi, T., Nomura, T., Tsujita, M., Suzuki, M., Fuse, T., Mori, H. and Mishina, M. Flp recombinase transgenic mice of C57BL/6 strain for conditional gene targeting. *Biochem. Biophys. Res. Commun.* 293, 953-957, 2002.
 48. Yoshida, T., Ito, A., Matsuda, N. and Mishina, M. Regulation by protein kinase A switching of axonal pathfinding of zebrafish olfactory sensory neurons through the olfactory placode-olfactory bulb boundary. *J. Neurosci.* 22, 4964-4972, 2002.
 49. Uemura, T., Mori, H. and Mishina, M. Isolation and characterization of Golgi apparatus-specific GODZ with the DHHC zinc finger domain. *Biochem. Biophys. Res. Commun.* 296, 492-496, 2002.
 50. Ichikawa, R., Miyazaki, T., Kano, M., Hashikawa, T., Tatsumi, H., Sakimura, K., Mishina, M., Inoue, Y., and Watanabe, M. Distal extension of climbing fiber territory and multiple innervation caused by aberrant wiring to adjacent spiny branchlets in cerebellar Purkinje cells lacking glutamate receptor GluR $\delta 2$. *J. Neurosci.* 22, 8487-8503, 2002.
 51. Tokuoka, H., Yoshida, T., Matsuda, N. and Mishina, M. (2002) Regulation by GSK-3 β of the arborization field and maturation of retinotectal projection in zebrafish. *J. Neurosci.*, in press.

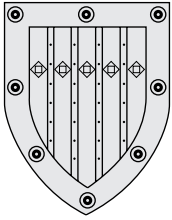

Department of Human Pathology

Outline and Research Objectives

The Department of Human Pathology was established in 1997, originating from the First Department of Pathology of the Faculty of Medicine. The Department of Human Pathology is specifically dedicated to the research of anatomical and surgical pathology of human diseases.

The Department of Pathology was established in 1887 and has a long history of both anatomical and experimental pathology. Professor Dr. Katsusaburo Yamagiwa (professor: 1905-1923) was the first in the world who succeeded in inducing skin carcinoma on rabbit ears with coal tar in 1908. He was also known to publish a book regarding the carcinogenesis of the stomach. The First and the Second Department Pathology, like as one unit, were engaged in research, diagnosis and teaching. The main research topics of the Department in one hundred years, either anatomical or experimental, varied according to the specialties of its professors and the academic demands of the time in Japan. A brief list of the topics includes clonorchiasis, tsutsugamushi disease, beriberi and salivary gland hormones which were investigated before World War II, and thereafter pathology of atomic bomb injuries, tuberculosis, hepatic disorders, bone marrow pathology and neoplastic diseases of various organs (e.g., stomach, liver, and bone). The experimental aspects of pathology are now succeeded and have been developed by the Department of Molecular Pathology.

The practice of anatomical pathology was a basis of research in the past, but it still constitutes a source of ideas even in the research-oriented pathology. The number of autopsies conducted from 1883 to the present has reached 33,950 and in spite of the current decline in the autopsy rate, one hundred autopsies are still performed each year. Surgical pathology has increasingly become important in the practice of pathology. The laboratory of surgical pathology in the University Hospital, which was established in 1955, became an independent division of the central laboratory of the hospital in 1975. After the integration of the Branch Hospital into the University Hospital in 2001, the numbers of histological and cytological specimens examined each year are expected to be more than 12,000 and 20,000, respectively. The division has been run with the cooperation of the Department of Pathology.

The Department of Human Pathology has succeeded the classical aspects of the Department of Pathology. Its mission is to be the bridge between clinical medicine and basic life sciences. Its research objectives are (1) to discover a new entity of human diseases based on the practice of anatomical and surgical pathology, (2) to clarify disease mechanisms based on morphology, and (3) to function as a "museum" for various forms of human disorders.

Faculties and Students

Professor and Chair	Masashi Fukayama, M.D., D.M.Sc. (1999-)
Associate Professors	Toshiro Niki, M.D., D.M.Sc., Ph.D.
Lecturer	Ja-Mun Chong, M.D., D.M.Sc.
Associate	3
Graduate student	13
Research student.....	2

Past Research and Major Accomplishments

Our research projects in the past ten years attempt to investigate the role of chronic inflammation in the development and progression of carcinoma. We focused our investigations on the following diseases:

(1) Epstein-Barr virus (EBV)-associated neoplasms, such as gastric carcinomas, pyothorax-associated lymphoma (PAL), Hodgkin's disease and AIDS lymphomas, and (2) lung carcinomas in patients with pulmonary fibrosis and lung adenocarcinoma with central scar formation.

1. EBV-associated neoplasms

EBV is the first virus that was identified in a human neoplastic cell in 1963. More than 90% of the world population is infected with EBV before adolescence, and it is thought that certain small populations develop EBV-associated malignancy in an endemic manner, such as Burkitt's lymphoma in equatorial Africa and nasopharyngeal carcinoma in Southern China. However, recent advances in molecular biological techniques have

demonstrated that various neoplasms in the general population are associated with EBV infection.

1-1) EBV-associated gastric carcinoma

EBV-associated gastric carcinoma is now considered to be the most common among EBV-associated neoplasms, and its frequency is 10% or less of gastric carcinomas in Japan. We found that EBV-associated gastric carcinoma is a distinct subgroup of gastric carcinoma, and that it develops against a background of severe atrophic gastritis. In our evaluation of genetic abnormalities, EBV-associated gastric carcinoma was found to be remarkable in its paucity of loss of heterozygosity (LOH) and microsatellite instability.

Since it is difficult to maintain epithelial cells *in vitro* in the latent form of EBV infection, we established one strain of EBV-associated gastric carcinoma transplantable to severe combined immunodeficiency (SCID) mice, which faithfully maintains the original EBV and the expression of EBV-related genes. Applying the DNA-chip analysis to the gastric carcinoma strains with or without EBV-infection in SCID mice, we clarified the expression profile specific to EBV-associated gastric carcinoma, and found that the expression of IL1- β is markedly up-regulated in this type of carcinoma. Of interest is the observation that IL1- β facilitates the growth of a gastric cancer cell line, suggesting that it is an autocrine growth factor in EBV-associated gastric carcinoma.

1-2) EBV-associated lymphomas

PAL develops within the pleural cavity of patients who had a 20-50-year history of pyothorax following tuberculous pleuritis or an artificial pneumothorax for the treatment of pulmonary tuberculosis. Although the reason is not clear at present, most patients of PAL are Japanese. We discovered in 1993 that EBV is causally associated with PAL and that PAL shows the same expression pattern of EBV latency genes as that of AIDS lymphomas.

2. Lung carcinoma

Lung cancer is the major cause of cancer-related deaths among Japanese. Since one of our specialties is the pathology of lung and thymus, two issues are under investigation, that is, the relationship between pulmonary fibrosis and development of lung cancer, and the role of fibrosis in the progression of adenocarcinoma.

2-1) Idiopathic pulmonary fibrosis and lung carcinoma

We evaluated the frequency of lung cancer among the patients with idiopathic pulmonary fibrosis (IPF) by performing autopsy-based case control study. Then, we morphologically evaluated the atypical epithelial proliferation in the honeycombed area.

Although squamous metaplasia is much more frequent in the honeycombed area of IPF patients with lung carcinoma, we confirmed the necessity to evaluate the genetic abnormalities in minute foci of atypical epithelial cells in tissue sections.

2-2) Small adenocarcinoma

Among nonsmall cell carcinomas of the lung, the prognosis of adenocarcinoma is relatively poor. One-third of the patients with stage I adenocarcinoma die of the disease within five years after surgery, and the 5-year recurrence rate is as high as 20% for adenocarcinomas of less than 2 cm in diameter. In our study of small adenocarcinoma, inactivation of p16 may play a role in accelerating scar formation and lymph node metastasis, and through these mechanisms p16-inactivation may contribute to a poor prognosis of the patients.

Current Research

1. EBV-associated neoplasms

1-1) Global methylation in EBV-associated gastric carcinoma

Recently we discovered the phenomenon of global and nonrandom methylation of the promoter region of cancer-associated genes in EBV-associated gastric carcinoma. Such a global methylation was not observed in EBV-negative carcinomas. One of the important roles of DNA methylation is to act as a defense against extrinsic pathogens. The latent infection of viruses in either episomal (EBV), or integrated form (human immunodeficiency virus type 1 or human T-cell leukemia-virus type-1), is restricted by methylation of viral genomes. Thus, we are now investigating a possible mechanism; that is, overridden methylation of cellular genes suppresses expression of important genes of EBV-infected epithelial cells, leading to the development of carcinoma.

1-2) EBV-associated lymphomas and human herpes virus 8

Human herpes virus 8 (HHV8) was first discovered in tissues of Kaposi sarcoma in 1994, and is associated with primary effusion lymphoma and multicentric Castleman's disease. However, its epidemiology in lymphoproliferative disorders and its relation to EBV have not been fully clarified. We are now investigating the molecular epidemiology of HHV8-associated diseases in Japan and Asian countries.

2. Lung carcinoma

2-1) Laser capture microscopy-assisted analysis of precursor lesions

Laser capture microscopy (LCM) is now widely applied to analysis of precursor lesions of various carcinomas. We are also applying it to the evaluation of epithelial cells of honeycombed areas in the diseased lungs of IPF patients, and atypical epithelial cells of adenomatous hyperplasia, a precursor of bronchioloalveolar carcinoma of the lung. Nuclei of target cells directly obtained from paraffin-embedded sections are subjected to PCR-based analysis.

Invasion-associated gene expression: Niki et al demonstrated the colocalization of cox-2 and laminin-5 at the invasive front of early-stage lung adenocarcinomas. Current data suggest that p53 abnormalities and EGFR signaling are involved in the aberrant expression of these proteins. Coregulation and interaction of these molecules at the invasive front of cancer may facilitate tumor angiogenesis and invasion in a coordinated manner. Several on-going projects investigate the expression of invasion-associated proteins in lung adenocarcinoma, including S100-related proteins. We are also developing a technique that enables us to apply DNA-chip analysis to tiny tissues of the invasive front using the LCM-assisted sampling.

2-2) Morphological analysis of lung carcinoma and thymic tumors

It is still necessary to review the histology of these neoplasms in order to develop an evaluation system for invasiveness and to identify the specific subgroups of neoplasms.

Future Prospects

There are two opposite directions that pathology is expected to pursue at present and in the future. One is to be included among the fields of life science and cell biology. The other is to remain a basic field for clinical medicine, which in its essence is a good partner and critic of clinical medicine. To keep up with the growing demand for an intimate relationship with clinical medicine, we have decided to combine our department with the Division of Surgical Pathology of the University Hospital. The union is expected to facilitate cross talks between pathology and clinical medicine, which will lead us to our goal, namely, the discovery of a new entity of human diseases and the clarification of their mechanisms based on morphology.

We will also be obligated to maintain the museum function of human pathology. Since we have archives of paraffin blocks, including more than 20,000 autopsy specimens that were accumulated in these past 100

years, a new molecular approach will clarify changes of disease profiles in Japan in the 20th century.

Research Grants

1. 1997-1999: Grant in Aid for Scientific Research (B) from the Ministry of Education, Science, Sports and Culture of Japan. "Pulmonary fibrosis and development of lung carcinoma. Analysis of dysplastic and neoplastic epithelial cells of pulmonary fibrosis."
2. 1999-2002: Grant in Aid for Scientific Research (B) from the Ministry of Education, Science, Sports and Culture of Japan. "Molecular epidemiology of human herpes virus 8-associated diseases in Japan and Asia."
3. 2001: Grant in Aid for Scientific Research on a Priority Area (C) from the Ministry of Education, Science, Sports and Culture of Japan. "Establishment of gene diagnosis system for lung adenocarcinoma."
4. 2002: Grant in Aid for Scientific Research on a Priority Area (C) from the Ministry of Education, Culture, Sports, Science and Technology of Japan. "Establishment of gene diagnosis system for lung adenocarcinoma."
5. 2002-2004: Grant in Aid for Scientific Research (A) from the Ministry of Education, Culture, Sports, Science and Technology of Japan. "Pathogenesis of Epstein-Barr virus-associated neoplasms."

Select Publications

1. Fukayama M, Hayashi Y, Takizawa t, Koike M, Endo S and Okumura H. Glycoprotein hormone alpha-subunit in human stomach. *J Histochem Cytochem* 34, 995-1001, 1986.
2. Fukayama M, Hayashi Y, Koike M, Hajikano H and Okumura H. Human chorionic gonadotropin in lung and lung tumors. Immunohistochemical study on unbalanced distribution of subunits. *Lab Invest* 55, 433-443, 1986.
3. Fukayama M, Hayashi Y and Koike M. Human chorionic gonadotropin in gastric carcinoma. An immunohistochemical study suggesting independent regulation of subunits. *Virchows Arch (Pathol Anat)* 411, 205-212, 1987
4. Fukayama M and Koike M. So-called sclerosing hemangioma of the lung. An immunohistochemical, histochemical and ultrastructural study. *Acta Pathol Jpn* 38, 627-642, 1988.
5. Fukayama M, Maeda Y, Funata N, Koike M, Saito K, Sakai T and Ikeda T. Pulmonary and pleural thymoma. Diagnostic application of lymphocyte markers to the thymoma of unusual site. *Am J Clin Pathol* 89, 617-621, 1988.
6. Fukayama M, Funata N, Hayashi Y, Maeda Y, Koike M, Wantanabe J and Okabe T: Brain associated small-cell lung cancer antigen (BASCA) in the lung and lung tumor. Immunohistochemical and immunoelectron microscopic study. *J Histochem Cytochem* 38, 51-57, 1990.

7. Fukayama M, Hayashi Y, Shiozawa Y, Furukawa E, Funata N and Koike M. Human chorionic gonadotropin α -subunit in endocrine cells of fibrotic and neoplastic lung. Its mode of localization and the size profile of granules. *Lab Invest* 62, 444-451, 1990.
8. Hayashi Y, Watanabe J, Nakata K, Fukayama M and Ikeda H. A novel diagnostic method of pneumocystis carinii. In situ Hybridization of ribosomal ribonucleic acid with biotinylated oligonucleotide probes. *Lab Invest* 63, 576-580, 1990.
9. Nakata K, Akagawa KS, Fukayama M, Hayashi Y, Kadokura M and Tokunaga T: Granulocyte-macrophage colony-stimulating factor promotes the proliferation of human alveolar macrophages in vitro. *J Immunol* 147, 1266-1272, 1991.
10. Fukayama M, Kanno T, Brody S, Kirby M and Crystal RG. Respiratory tract gene transfer. Transplantation of genetically modified T-lymphocytes directly to the respiratory surface. *J Biol Chem* 266, 18339-1844, 1991
11. Rosenfeld MA, Siegfried W, Yoshimura K, Yoneyama K, Fukayama M, Stier LE, Paakko PK, Gilardi P, Stratford-Perricaudet LD, Perricaudet M, Jallat S, Pavirani A, Lecocq J and Crystal RG. Adenovirus-mediated transfer of a recombinant α 1-antitrypsin gene to the lung epithelium in vivo. *Science* 252, 431-252, 1991.
12. Rosenfeld MA, Yoshimura K, Trapnell BC, Yoneyama K, Rosenthal ER, Dalemans W, Fukayama M, Bargon J, Stier LE, Stratford-Perricaudet L, Perricaudet M, Guggino WB, Pavirani A, Lecocq J and Crystal RG. In vivo transfer of the human cystic fibrosis transmembrane conductance regulator gene to the airway epithelium. *Cell* 68, 143-155, 1992.
13. Kikuchi-Yanoshita R, Konishi M, Ito S, Seki M, Tanaka K, Maeda Y, Iino H, Fukayama M, Koike M, Mori T, Sakuraba H, Fukunari H, Iwama T and Miyaki M. Genetic changes of both p53 alleles associated with the conversion from colorectal adenoma to early carcinoma in familial adenomatous polyposis and non-familial adenomatous polyposis patients. *Cancer Res* 52, 3965-3971, 1992.
14. Fukayama M, Ibuka T, Hayashi Y, Ooba T, Koike M and Mizutani S. Epstein-Barr virus in pyothorax-associated pleural lymphoma. *Am J Pathol* 143, 1044-1049, 1993.
15. Hayashi Y, Fukayama M, Koike M, Kaseda S, Ikeda T and Yokoyama T. Cell-cycle analysis detecting nuclear antigens: Comparison with BrdU-in vivo labeling and application to lung tumors. *Acta Pathol Jpn* 43, 313-319, 1993.
16. Fukayama M, Hayashi Y, Iwasaki Y, Chong J, Ooba T, Takizawa T, Koike M, Mizutani S, Miyaki M and Hirai K. Epstein-Barr virus (EBV)-associated gastric carcinoma and EBV-infection of the stomach. *Lab Invest* 71, 73-81, 1994.
17. Ibuka T, Fukayama M, Hayashi Y, Funata N, Koike M, Ikeda T and Mizutani S. Pyothorax-associated pleural lymphoma: A case evolving from T-cell rich lymphoid infiltration to overt B-cell lymphoma in association with Epstein-Barr virus. *Cancer* 73, 738-743, 1994.
18. Iino H, Fukayama M, Maeda Y, Koike M, Mori T, Takahashi T, Kikuchi-Yanoshita R, Miyaki M, Mizuno S and Watanabe S. Molecular genetics for clinical management of colorectal carcinoma. 17p, 18q, and 22q loss of heterozygosity and decreased DCC expression are correlated with the metastatic potential. *Cancer* 73, 1324-1331, 1994.
19. Miyaki M, Konishi M, Kikuchi-Yanoshita R, Enomoto M, Igari T, Tanaka K, Muraoka M, Takahashi H, Amada Y, Fukayama M, Maeda M, Iwama T, Mishima Y and Koike M. Characteristics of somatic mutation of the adenomatous polyposis coli gene in colorectal tumors. *Cancer Res* 54, 3011-3020, 1994.
20. Hishima T, Fukayama M, Fujisawa M, Hayashi Y, Arai K, Funata N, Koike M: CD5 expression in thymic carcinoma. *Am J Pathol* 145:268-1994.
21. Chong J, Fukayama M, Hayashi Y, Takizawa T, Koike M, Konishi M, Kikuchi-Yanoshita R, Miyaki M: Microsatellite instability in the progression of gastric carcinoma. *Cancer Res*, 54:4595-4597, 1994.
22. Fukayama M, Hayashi Y, Ooba T, Funata N, Ibuka T, Koike M, Hebisawa A, Kurasawa A, Fukayama M, Nakahiro K and Kudoh S. Pyothorax-associated lymphoma: development of Epstein-Barr virus-associated lymphoma within the inflammatory cavity. *Pathol Int* 45, 825-831, 1995
23. Egawa N, Fukayama M, Kawaguchi K, Hishima T, Hayashi Y, Funata N, Ibuka T, Koike M, Miyashita H and Tajima T. Relapsing oral and colonic ulcers with monoclonal T-cell infiltration. A low grade mucosal T-lymphoproliferative disease of the digestive tract. *Cancer* 75, 1728-1733, 1995.
24. Shimada-Hiratuka M, Fukayama M, Hayashi Y, Ushijima T, Suzuki M, Hishima T, Funata N and Koike M, Watanabe T. Primary gastric T-cell lymphoma with and without human T-lymphotropic virus type 1. *Cancer* 80, 292-303, 1997.
25. Harada M, Suzuki M, Ikeda T, Kaneko T, Harada S and Fukayama M. Clonality in nevocellular nevus and malignant melanoma. An expression-based clonality analysis at the X-linked genes by polymerase chain reaction. *J Invest Dermatol* 109, 656-660, 1997.
26. Chong J-M, Fukayama M, Hayashi Y, Funata N, Takizawa T, Koike M, Kikuchi-Yanoshita R, Miyaki M and Mizuno S. CD44 variants in gastric carcinoma in association with or without Epstein-Barr virus. *Int J Cancer* 74:450-454, 1997
27. Chong J, Fukayama M, Hayashi Y, Hishima T, Funata N, Koike M, Matsuya S, Konishi M and Miyaki M. Microsatellite Instability and loss of heterozygosity in gastric lymphoma. *Lab Invest* 77, 639-645, 1997.
28. Hishima T, Fukayama M, Hayashi Y, Fujii T, Arai K, Shiozawa Y, Funata N and Koike M: Neuroendocrine differentiation in thymic epithelial tumors with special reference to thymic carcinoma and atypical thymoma. *Hum Pathol* 29, 330-338, 1998.

29. Iwasaki Y, Chong J-M, Hayashi Y, Ikeno R, Arai K, Kitamura M, Koike M, Hirai K and Fukayama M: Establishment and characterization of a human Epstein-Barr virus-associated gastric carcinoma in SCID mice. *J Virol* 72, 8321-8326, 1998.
30. Sakurai S, Fukayama M, Kaizaki Y, Saito K, Kanazawa K, Kitamura M, Iwasaki Y, Hishima T, Hayashi Y and Koike M: Telomerase Activity in Gastrointestinal Stromal Tumor (GIST). *Cancer* 83, 2060-2066, 1998.
31. Fukayama M, Chong JM and Kaizaki Y. Epstein-Barr virus and gastric carcinoma. *Gastric Cancer* 1, 104-114, 1998.
32. Ishida T, Takashima R, Fukayama M, Hamada C, Hippo Y, Fujii T, Moriyama S, Matsuba C, Nakahori Y, Morita H, Yazaki Y, Kodama T, Nishimura S and Aburatani H. New DNA polymorphisms of human MMH/OGG1 gene: prevalence of one polymorphism among lung- adenocarcinoma patients in Japanese. *Int J Cancer* 80, 18-21, 1999.
33. Sakurai S, Fukasawa T, Chong JM and Fukayama M. Embryonic Form of Smooth Muscle Myosin Heavy Chain (SMemb/MHC-B) in Gastrointestinal Stromal Tumor and Interstitial Cells of Cajal. *Am J Pathol* 154, 23-28, 1999.
34. Kawabuchi B, Moriyama S, Hironaka M, Fujii T, Koike M, Moriyama H, Nishimura Y, Mizuno S and Fukayama M. p16 inactivation in small sized lung adenocarcinoma: its association of poor prognosis. *Int J Cancer* 84, 49-53, 1999.
35. Hayashi Y, Fukayama M, Funata N, Hishima T, Oba T and Koike M. Polymerase chain reaction-screening of immunoglobulin heavy chain and T-cell receptor gene rearrangements. A practical approach to molecular DNA analysis of non-Hodgkin's lymphoma in a surgical pathology laboratory. *Pathol Int* 49, 110-117, 1999.
36. Kaizaki Y, Sakurai S, Chong JM and Fukayama M: Atrophic gastritis, Epstein-Barr virus infection, and Epstein-Barr virus-associated gastric carcinoma. *Gastric Cancer* 2, 101-108, 1999.
37. Koshiishi N, Chong JM, Fukasawa T, Ikeno R, Tanaka A, Kanazawa K, Ogura M, Ebuchi M, Takizawa T, Funata N and Fukayama M. Microsatellite instability and loss of heterozygosity in primary and secondary proliferative lesions of the parathyroid gland. *Lab Invest* 79, 1051-1058, 1999.
38. Sakurai S, Fukasawa T, Chong JM, Tanaka A and Fukayama M. *C-kit* gene abnormalities in gastrointestinal stromal tumors (tumors of interstitial cell of Cajal). *Jpn J Cancer Res* 90, 1321-1328, 1999.
39. Hironaka M and Fukayama M. Pulmonary fibrosis and lung carcinoma: A comparative study of metaplastic epithelia in honeycombed areas of usual interstitial pneumonia with or without lung carcinoma. *Pathol Int* 49, 1060-1066, 1999.
40. Hishima T, Fukayama M, Hayashi Y, Fujii T, Ooba T, Funata N and Koike M. CD70 in thymic carcinoma. *Am J Surg Pathol* 25, 742-746, 2000.
41. Kurihara K, Shimizu S, Chong JM, Hishima T, Funata N, Kashiwagi H, Nagai H, Miyaki M and Fukayama M. Nuclear localization of immunoreactive b-catenin is specific to familial adenomatous polyposis in papillary thyroid carcinoma. *Jpn J Cancer Res* 91, 1100-1102, 2000.
42. Fukasawa T, Chong JM, Sakurai S, Koshiishi N, Ikeno R, Tanaka A, Matsumoto Y, Hayashi Y, Koike M and Fukayama M. Allelic loss of 14q, and 22q, *NF2* mutation, and genetic instability occur independently of c-kit mutation in gastrointestinal stromal tumor. *Jpn J Cancer Res* 91, 1241-1249, 2000.
43. Fukayama M, Chong JM and Uozaki H. Pathology and molecular pathology of Epstein-Barr virus-associated gastric carcinoma. *Curr Top Microbiol Immunol* 258, 91-102, 2001.
44. Takeuchi K, Morishita Y, Fukayama M and Mori S. Marked decrease in the Epstein-Barr virus positivity rate in nodular sclerosis subtype Hodgkin's disease in Tokyo: trend between 1955 and 1999. *Br J Haematol* 113, 429-431, 2001.
45. Sakurai S, Oguni S, Hironaka M, Fukayama M, Morinaga S and Saito K. Mutations in c-kit gene exons 9 and 13 in gastrointestinal stromal tumors among Japanese. *Jpn J Cancer Res* 92, 494-498, 2001.
46. Hippo Y, Taniguchi H, Tsutsumi S, Machida N, Chong JM, Fukayama M, Kodama T and Aburatani H. Global gene expression analysis of gastric cancer by oligonucleotide microarrays. *Cancer Res*, 62, 233-240, 2002.
47. Niki T, Kohno T, Iba S, Moriya Y, Takahashi Y, Saito M, Maeshima A, Yamada T, Matsuno Y, Fukayama M, Yokota J and Hirohashi S. Frequent Co-Localization of Cox-2 and Laminin-5 gamma2 Chain at the Invasive Front of Early-Stage Lung Adenocarcinomas. *Am J Pathol*, 160, 1129-1141, 2002.
48. Chong JM, Sakuma K, Sudo M, Osawa T, Ohara E, Uozaki H, Shibahara J, Kuroiwa K, Tominaga S, Hippo Y, Aburatani H, Funata N and Fukayama M. Interleukin-1beta expression in human gastric carcinoma with Epstein-Barr virus infection. *J Virol* 76, 6825-6831, 2002.
49. Kakiuchi C, Ishida T, Sato H, Katano H, Ishiko T, Mukai H, Kogi M, Kasuga N, Takeuchi K, Yamane K, Fukayama M and Mori S. Secretion of interleukin-6 and vascular endothelial growth factor by spindle cell sarcoma complicating Castleman's disease (so-called 'vascular neoplasia'). *J Pathol* 197, 264-271, 2002.
50. Osawa T, Chong J-M, Sudo M, Sakuma K, Uozaki H, Shibahara J, Nagai H, Funata N and Fukayama M. Reduced Expression and Promotor Methylation of p16 Gene in Epstein-Barr Virus-associated Gastric Carcinoma. *Jpn J Cancer Res* in press.

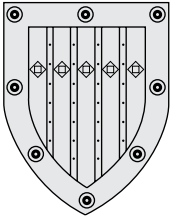

Department of Molecular Pathology

Outline and Research Objectives

Our department has a more than 100-year history from its establishment as the Department of Pathology. The Second Department of Pathology has changed its name to the Department of Molecular Pathology; after the retirement of Dr. Takatoshi Ishikawa, Dr. Miyazono began to work as the Professor of the Department.

Our research is focused on molecular mechanisms of carcinogenesis, using molecular biological techniques. Transforming growth factor- β (TGF- β) is a potent growth inhibitor for many cells, and perturbations of TGF- β signaling result in progression of various cancers. We are interested in the signaling mechanisms of the TGF- β superfamily, including TGF- β and bone morphogenetic proteins (BMPs), and studying how TGF- β signals regulate progression of various cancers, e.g. colorectal cancer.

We are also interested in the pathogenesis of vascular diseases. Signals induced by TGF- β and BMPs play important roles in the development and homeostasis of blood vessels. Abnormalities in TGF- β /BMP signals result in genesis of certain vascular disorders. We have recently started to investigate the mechanisms of growth and differentiation of murine embryonic stem (ES) cells. Using an in vitro system, we are trying to regulate the differentiation of ES cells into smooth muscle cells (SMCs) and endothelial cells (ECs). The results will be useful for the development of new strategies for treatment of cancers and vascular diseases.

Faculty and Students

- Professor and Chair Kohei Miyazono, M.D., D.M.S. (from 2000)
- Associate Professors Keiji Miyazawa, Ph.D.
- Associates2
- Postdoctoral Fellow1
- Research Technicians4
- Ph.D. Students2
- Master Course Students3
- Visiting Researcher1
- Visiting Ph.D. Students7
- Secretaries2

Past Research and Major Accomplishments

Members of the TGF- β superfamily bind to two different types of serine/threonine kinase receptors, and activate intracellular signaling molecules, the Smads. Smads move into the nucleus and regulate transcription of target genes, including c-myc and cyclin-dependent kinase inhibitors. Signaling by Smads is regulated by various molecules, including inhibitory Smads (I-Smads) and transcriptional co-repressors, c-Ski and SnoN (Figure 1).

We isolated cDNAs for TGF- β type I receptor (T β R-I, also called ALK-5) in 1993 [3]. In addition, we have cloned five additional type I receptors, which turned out to be the type I receptors for BMPs and

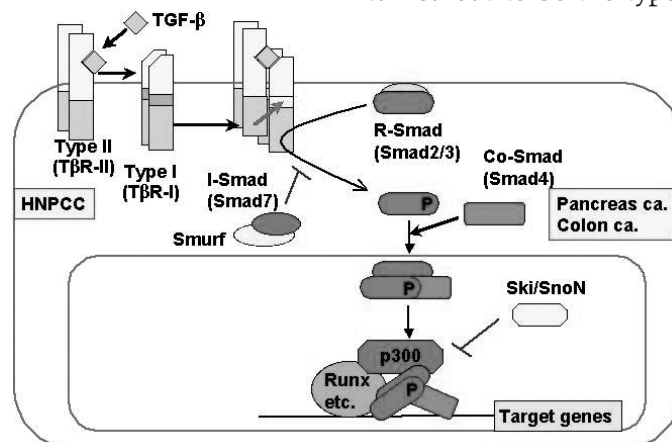

Figure 1. Signaling by TGF- β through serine/threonine kinase receptors and Smads

activins [6], and the type II receptor for BMPs (BMPRII) [11]. Using these receptors, we demonstrated how the members of the TGF- β superfamily bind to different combinations of type II and type I receptors.

During our studies of intracellular signaling activated by the serine/threonine kinase receptors, we have cloned one of the mammalian I-Smads, Smad6 [17], and reported that Smads can be classified into three subclasses, i.e. R-Smads, Co-Smads, and I-Smads [18]. Moreover, we demonstrated how I-Smads inhibit signaling activities of the TGF- β superfamily cytokines [27, 29, 44]. We have shown that E3 ubiquitin ligases, Smurfs, interact with I-Smads, recruit them from the nucleus to the cell surface receptor complexes, and induce ubiquitination and degradation of the type I receptors [40, 48]. These findings suggested that Smurfs support the inhibitory activity of I-Smads in TGF- β superfamily signaling.

We have also investigated the mechanisms by which Smads regulate transcription of target genes of the TGF- β superfamily cytokines. We have shown that Smads interact with various transcription factors, including the vitamin D3 receptor and Runx proteins (also known as Cbfa/AML/PEBP2 α proteins) [25, 30, 37], which play important roles for TGF- β superfamily cytokines in exhibiting various biological effects in different types of cells. In addition, we demonstrated that Smads interact with transcriptional co-activators, p300 and CBP, and transcriptional co-repressors, c-Ski and SnoN [26, 31]. c-Ski was originally identified as an oncogene. Our findings suggest that c-Ski may regulate growth and differentiation of various cells through regulating the actions of Smads.

We are also studying vascular diseases induced by perturbation of the TGF- β /BMP signaling systems. Hereditary hemorrhagic telangiectasias (HHTs) are induced by mutations of the human *endoglin* or *ALK-1* genes. *ALK-1*-null mice exhibit vascular abnormalities reminiscent of human HHT [34]. Primary pulmonary hypertension (PPH) is induced by mutations of BMPRII; however, we have shown that mutations

occur in various portions of the BMPRII in PPH patients, which may contribute in different fashions to the pathogenesis of this disease [47]. Using adenovirus vectors containing constitutively active forms of TGF- β type I receptor (ALK-5) or ALK-1, we have identified target genes induced by these receptors. These findings will become useful for our future studies designed to elucidate the mechanisms of pathogenesis of vascular diseases induced by abnormalities of TGF- β and BMP signaling.

Current Research

Our current research activities are focused on two major projects. First, we are trying to elucidate the signaling mechanisms of the TGF- β superfamily through Smad proteins, and to modulate TGF- β signaling by various molecules. Many tumor cells are resistant to the growth inhibitory activity of TGF- β . Thus, perturbations of TGF- β superfamily signaling result in progression of various cancers, including hereditary non-polyposis colorectal cancer (HNPCC) and pancreatic cancer (Figure 1). However, the molecular mechanisms of the resistance to effects of TGF- β are still not fully understood. We have recently shown that cis-compound disruption of murine *Smad2* gene accelerates malignant progression of intestinal tumors in *Apc* knockout mice [49]. Moreover, we have shown that TGF- β regulates transcription of *c-myc* through Smads [45], and we are currently studying the molecules that regulate *c-myc* transcription together with Smads, including the TCF-4/Lef-1 family of transcription factors.

We have shown that I-Smads and c-Ski/SnoN negatively regulate TGF- β signaling. Based on their three-dimensional structures, we are trying to elucidate how these inhibitory molecules interact with the TGF- β receptors or Smads. We are also trying to identify novel molecules that regulate TGF- β /BMP signaling by yeast two-hybrid systems and DNA microarray analyses. Experiments using *Xenopus* embryos which

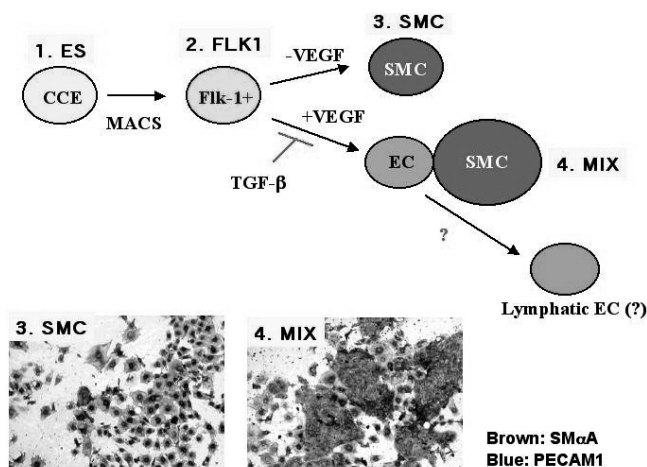

Figure 2. Differentiation of ES cells into ECs and SMCs in vitro.

we have recently started in our laboratory will be useful for examining the biological activities regulated by these molecules. Although perturbations of TGF- β signaling result in malignant progression of tumors, tumor cells by themselves produce large amounts of TGF- β , which induce progression of tumors through induction of neovascularization, inhibition of immune function, and accumulation of extracellular matrices. We have recently found that adenoviruses containing Smad7 and c-Ski prevented metastasis of breast tumors in nude mice. Thus, molecules that negatively regulate TGF- β signaling may be useful for regulation of progression and/or metastasis of certain cancers.

Our second project is to study the growth and differentiation of murine ES cells. Formation of new blood vessels involves the proliferation and differentiation of endothelial progenitor cells (EPCs) circulating in peripheral blood. We are studying whether TGF- β superfamily signals play roles during the differentiation of EPCs into endothelial cells (ECs) and smooth muscle cells (SMCs) using an *in vitro* ES cell system (Figure 2). Our preliminary findings suggest that the balance of two major signaling pathways of the TGF- β superfamily cytokines, i.e. TGF- β -like signals and BMP-like signals, plays important roles in the differentiation of EPCs into ECs and SMCs. We also found that TGF- β regulates differentiation and formation of tight junction of ECs. Moreover, we have obtained some evidence that certain fractions of ECs express specific markers for lymphatic ECs, suggesting that lymphangiogenesis may be induced from EPCs.

Future Prospects

Our future goals will include further elucidation of signaling mechanisms of the TGF- β superfamily cytokines. Inhibition of TGF- β signaling by I-Smads or transcriptional co-repressors appears to be a powerful method of preventing tissue fibrosis and cancer metastasis. Development of molecules that regulate TGF- β signaling pathways may thus be useful for treatment of various clinical disorders. We will also extend our research to generate cells of different lineages from murine ES cells. Our knowledge of TGF- β and other cytokine signaling pathways will be useful in these projects. Generation of ECs and SMCs from ES cells will be valuable for treatment of various vascular diseases. Moreover, generation of lymphatic ECs will be useful for identification of genes specifically expressed in lymphatic tissues. These studies will thus be beneficial not only for application of these cells in the field of regenerative medicine, but also for development of new strategies for diagnosis and treatment of metastatic tumors.

Research Grants

1. Research for the Future Program: Study on the Signal Transduction by Serine-Threonine Kinase Receptors (1996-2000) Kohei Miyazono (284,485,000 JPY) Supported by the Japan Society for the Promotion of Science.
2. Grant-in-Aid for Scientific Research on Priority Areas (Advanced Research on Cancer): Signaling Mechanisms of TGF- β and Their Abnormalities in Human Cancer (2000-2004) Kohei Miyazono (224,270,000 JPY in 2000-2002) Supported by the Ministry of Education, Culture, Sports, Science, and Technology of Japan.
3. Grant-in-Aid for Scientific Research (A): Study on the Biological Activities of Serine-Threonine Kinase Receptors (2002-2005) Kohei Miyazono (40,900,000 JPY) Supported by the Japan Society for the Promotion of Science.
4. Grant-in-Aid for Scientific Research (B)(2): Signal Transduction by Smad Proteins and Their Biological Activities (1999-2001) Kohei Miyazono (14,900,000 JPY) Supported by the Ministry of Education, Culture, Sports, Science, and Technology of Japan and the Japan Society for the Promotion of Science.
5. Grant-in-Aid for Scientific Research (B) (2): Signal Transduction and Biological Activities of the Members of the TGF- β Superfamily (1997-1998) Kohei Miyazono (15,100,000 JPY) Supported by the Ministry of Education, Culture, Sports, Science, and Technology of Japan.

Select Publications (* indicates 10 select Publications, for which copies are attached)

1. Miyazono, K., Olofsson, A., Colosetti, P., and Heldin, C.-H. A role of the latent TGF- β 1-binding protein in the assembly and secretion of TGF- β 1. *EMBO J.* 10, 1091-1101, 1991.
2. ten Dijke, P., Ichijo, H., Franzén, P., Schulz, P., Saras, J., Toyoshima, H., Heldin, C.-H., and Miyazono, K. Activin receptor-like kinases: A novel subclass of cell surface receptors with predicted serine/threonine kinase activity. *Oncogene* 8, 2879-2887, 1993.
- 3.* Franzén, P., ten Dijke, P., Ichijo, H., Yamashita, H., Schulz, P., Heldin, C.-H., and Miyazono, K. Cloning of a TGF β type I receptor that forms a heteromeric complex with the TGF β type II receptor. *Cell* 75, 781-792, 1993.
4. Yamashita, H., Ichijo, H., Grimsby, S., Morén, A., ten Dijke, P., and Miyazono, K. Endoglin forms a heteromeric complex with the signaling receptors for transforming growth factor- β . *J. Biol. Chem.* 269, 1995-2001, 1994.
5. Taipale, J., Miyazono, K., Heldin, C.-H., and Keski-Oja, J. Latent transforming growth factor- β 1 associates to fibroblast extracellular matrix via latent TGF- β binding protein. *J. Cell Biol.* 124, 171-181, 1994.
- 6.* ten Dijke, P., Yamashita, H., Ichijo, H., Franzén, P., Laiho, M., Miyazono, K., and Heldin, C.-H.

- Characterization of type I receptors for transforming growth factor- β and activin. *Science* 264, 101-104, 1994.
7. ten Dijke, P., Yamashita, H., Sampath, T.K., Reddi, A.H., Estevez, M., Riddle, D.L., Ichijo, H., Heldin, C.-H., and Miyazono, K. Identification of type I receptors for osteogenic protein-1 and bone morphogenetic protein-4. *J. Biol. Chem.* 269, 16985-16988, 1994.
 8. Okadome, T., Yamashita, H., Franzén, P., Morén, A., Heldin, C.-H., and Miyazono, K. Distinct roles of the intracellular domains of transforming growth factor- β type I and type II receptors in signal transduction. *J. Biol. Chem.* 269, 30753-30756, 1994.
 9. Yamashita, H., Okadome, T., Franzén, P., ten Dijke, P., Heldin, C.-H., and Miyazono, K. A rat pituitary tumor cell line (GH₃) expresses type I and type II receptors and other cell surface binding protein(s) for transforming growth factor- β . *J. Biol. Chem.* 270, 770-774, 1995.
 - 10.* Yamashita, H., ten Dijke, P., Huylebroeck, D., Sampath, T.K., Andries, M., Smith, J.C., Heldin, C.-H., and Miyazono, K. Osteogenic protein-1 binds to activin type II receptors and induces certain activin-like effects. *J. Cell Biol.* 130, 217-226, 1995.
 11. Rosenzweig, B.L., Imamura, T., Okadome, T., Cox, G.N., Yamashita, H., ten Dijke, P., Heldin, C.-H., and Miyazono, K. Cloning and characterization of a human type II receptor for bone morphogenetic proteins. *Proc. Natl. Acad. Sci. USA* 92, 7632-7636, 1995.
 12. Nishitoh, H., Ichijo, H., Kimura, M., Matsumoto, T., Makishima, F., Yamaguchi, A., Yamashita, H., Enomoto, S., and Miyazono, K. Identification of type I and type II serine/threonine kinase receptors for growth/differentiation factor-5. *J. Biol. Chem.* 271, 21345-21352, 1996.
 13. Souchelnytskyi, S., ten Dijke, P., Miyazono, K., and Heldin, C.-H. Phosphorylation of Ser165 in TGF- β type I receptor modulates TGF- β 1-induced cellular responses. *EMBO J.* 15, 6231-6240, 1996.
 - 14.* Ichijo, H., Nishida, E., Irie, K., ten Dijke, P., Saitoh, M., Moriguchi, T., Takagi, M., Matsumoto, K., Miyazono, K., and Gotoh, Y. Induction of apoptosis by ASK1, a mammalian MAPKKK that activates SAPK/JNK and p38 signaling pathways. *Science* 275, 90-94, 1997.
 15. Nakajima, Y., Miyazono, K., Kato, M., Takase, M., Yamagishi, T., and Nakamura, H. Extracellular fibrillar structure of latent TGF β binding protein-1: Role in TGF β -dependent endothelial-mesenchymal transformation during endocardial cushion tissue formation in mouse embryonic heart. *J. Cell Biol.* 136, 193-204, 1997.
 16. Nakao, A., Imamura, T., Souchelnytskyi, S., Kawabata, M., Ishisaki, A., Oeda, E., Tamaki, K., Hanai, J.-i., Heldin, C.-H., Miyazono, K., and ten Dijke, P. TGF- β receptor-mediated signalling through Smad2, Smad3 and Smad4. *EMBO J.* 16, 5353-5362, 1997.
 - 17.* Imamura, T., Takase, M., Nishihara, A., Oeda, E., Hanai, J.-i., Kawabata, M. and Miyazono, K. Smad6 inhibits signalling by the TGF- β superfamily. *Nature* 389, 622-626, 1997.
 - 18.* Heldin, C.-H., Miyazono, K., and ten Dijke, P. TGF- β signalling from cell membrane to nucleus through Smad proteins. *Nature* 390, 465-471, 1997.
 19. Saitoh, M., Nishitoh, H., Fujii, M., Takeda, K., Tobiume, K., Sawada, Y., Kawabata, M., Miyazono, K., and Ichijo, H. Mammalian thioredoxin is a direct inhibitor of apoptosis signal-regulating kinase (ASK) 1. *EMBO J.* 17, 2596-2606, 1998.
 20. Takeda, K., Ichijo, H., Fujii, M., Mochida, Y., Saitoh, M., Nishitoh, H., Sampath, T.K., and Miyazono, K. Identification of a novel bone morphogenetic protein-responsive gene that may function as a noncoding RNA. *J. Biol. Chem.* 273, 17079-17085, 1998.
 21. Inoue, H., Imamura, T., Ishidou, Y., Takase, M., Udagawa, Y., Tsuneizumi, K., Tabata, T., Miyazono, K., and Kawabata, M. Interplay of signal mediators of Decapentaplegic (Dpp): Molecular characterization of Mothers against dpp, Medea, and Daughters against Dpp. *Mol. Biol. Cell* 9, 2145-2156, 1998.
 - 22.* Kawabata, M., Inoue, H., Hanyu, A., Imamura T., and Miyazono, K. Smad proteins exist as monomers in vivo and undergo homo- and hetero-oligomerization upon activation by serine/threonine kinase receptors. *EMBO J.* 17, 4056-4065, 1998.
 23. Nishitoh, H., Saitoh, M., Mochida, Y., Takeda, K., Nakano, H., Rothe, M., Miyazono, K., and Ichijo, H. ASK1 is essential for JNK/SAPK activation by TRAF2. *Mol. Cell* 2, 389-395, 1998.
 24. Yagi, K., Goto, D, Hamamoto, T., Takenoshita, S., Kato, M. and Miyazono, K. Alternatively-spliced variant of Smad2 lacking exon 3: Comparison with wild-type Smad2 and Smad3. *J. Biol. Chem.* 274, 703-709, 1999.
 25. Yanagisawa, J., Yanagi, Y., Masuhiro, Y., Suzawa, M., Toriyabe, T., Kashiwagi, K., Watanabe, M., Kawabata, M., Miyazono, K., and Kato, S. Convergence of transforming growth factor- β and vitamin D signaling pathways on SMAD transcriptional coactivators. *Science* 283, 1317-1321, 1999.
 26. Nakashima, K., Yanagisawa, M., Arakawa, H., Kimura, N., Hisatsune, T., Kawabata, M., Miyazono, K., and Taga, T. Synergistic signaling in fetal brain by STAT3-Smad1 complex bridged by p300. *Science* 284, 479-482, 1999.
 27. Nakao, A., Fujii, M., Matsumura, R., Kumano, K., Saito, Y., Miyazono, K., and Iwamoto, I. Transient gene transfer and expression of Smad7 prevents bleomycin-induced lung fibrosis in mice. *J. Clin. Invest.* 104, 5-11, 1999.
 28. Nishihara, A., Hanai, J.-i., Imamura, T., Miyazono, K., and Kawabata, M. E1A inhibits transforming growth factor- β signaling through binding to Smad proteins. *J. Biol. Chem.* 274, 28716-28723, 1999.
 - 29.* Fujii, M., Takeda, K., Imamura, T., Aoki, H., Sampath, T.K., Enomoto, S., Kawabata, M., Kato, M., Ichijo, H., Miyazono, K. Roles of bone morphogenetic

- protein type I receptors and Smad proteins in osteoblastic and chondroblastic differentiation. *Mol. Biol. Cell* 10, 3801-3813, 1999.
30. Hanai, J.-i., Chen, L.F., Kanno, T., Ohtani-Fujita, N., Kim, W.Y., Guo, W.-H., Imamura, T., Ishidou, Y., Fukuchi, M., Shi, M.-J., Stavnezer, J., Kawabata, M., Miyazono, K., and Ito, Y. Interaction and functional cooperation of PEBP2/CBF with Smads: Synergistic induction of the immunoglobulin germline Ca promoter. *J. Biol. Chem.* 274, 31577-31582, 1999.
 31. Akiyoshi, S., Inoue, H., Hanai, J.-i., Kusanagi, K., Nemoto, N., Miyazono, K., and Kawabata, M. c-Ski acts as a transcriptional co-repressor in TGF- β signaling through interaction with Smads. *J. Biol. Chem.* 274, 35269-35278, 1999.
 32. Kusanagi, K., Inoue, H., Ishidou, Y., Mishima, H.K., Kawabata, M., and Miyazono, K. Characterization of a bone morphogenetic protein-responsive Smad binding element. *Mol. Biol. Cell* 11, 555-565, 2000.
 33. Ishida, W., Hamamoto, K., Kusanagi, K., Yagi, K., Kawabata, M., Takehara, K., Sampath, T.K., Kato, M., and Miyazono, K. Smad6 is a Smad1/5-induced Smad inhibitor: Characterization of bone morphogenetic protein-responsive element in the mouse *Smad6* promoter. *J. Biol. Chem.* 275, 6075-6079, 2000.
 34. Oh, S.P., Seki, T., Goss, K.A., Imamura, T., Yi, Y., Donahoe, P.K., Li, L., Miyazono, K., ten Dijke, P., Kim, S., and Li, E.) Activin receptor-like kinase 1 modulates transforming growth factor- β 1 signaling in the regulation of angiogenesis *Proc. Natl. Acad. Sci. USA* 97, 2626-2631, 2000.
 35. Miyazono, K. Positive and negative regulation of TGF- β signaling. *J. Cell Sci.* 113, 1101-1109, 2000.
 36. Beppu, H., Kawabata, M., Hamamoto, T., Chytil, A., Minowa, O., Noda, T., and Miyazono, K. BMP type II receptor is required for gastrulation and early development of mouse embryos. *Dev. Biol.* 221, 249-258, 2000.
 37. Zhang, Y.-W., Yasui, N., Huang, G., Fujii, M., Hanai, J.-i., Nogami, H., Ochi, T., Miyazono, K., and Ito, Y. A RUNX2/PEBP2 α A/CBFA1 mutation displaying impaired transactivation and Smad interaction in cleidocranial dysplasia. *Proc. Natl. Acad. Sci. USA* 97, 10549-10554, 2000.
 38. Miura, S., Takeshita, T., Asao, H., Kimura, Y., Murata, K., Sasaki, Y., Hanai, J.-i., Beppu, H., Tsukazaki, T., Wrana, J.L., Miyazono, K., and Sugamura, K. Hgs (Hrs), a FYVE domain protein, is involved in Smad signaling through cooperation with SARA. *Mol. Cell. Biol.* 20, 9346-9355, 2000.
 39. Yoshida, Y., Tanaka, S., Umemori, H., Minowa, M., Usui, M., Ikematsu, N., Hosoda, E., Imamura, T., Kuno, J., Yamashita, T., Miyazono, K., Noda, M., Noda, T., and Yamamoto, T. Negative regulation of BMP/Smad signaling by Tob in osteoblasts. *Cell* 103, 1085-1097, 2000.
 - 40.* Ebisawa, T., Fukuchi, M., Murakami, G., Chiba, T., Tanaka, K., Imamura, T., and Miyazono, K. Smurf1 interacts with transforming growth factor- β type I receptor through Smad7 and induces receptor degradation. *J. Biol. Chem.* 276, 12477-12480, 2001.
 41. Fukuchi, M., Imamura, T., Chiba, T., Ebisawa, T., Kawabata, M., Tanaka, K., and Miyazono, K. Ligand-dependent degradation of Smad3 by a ubiquitin ligase complex of ROC1 and associated proteins. *Mol. Biol. Cell* 12, 1431-1443, 2001.
 42. Furuhashi, M., Yagi, K., Yamamoto, H., Furukawa, Y., Shimada, S., Nakamura, Y., Kikuchi, A., Miyazono, K., and Kato, M. Axin facilitates Smad3 activation in the transforming growth factor- β signaling pathway. *Mol. Cell. Biol.* 21, 5132-5141, 2001.
 43. Kusanagi, K., Kawabata, M., Mishima, H.K., and Miyazono, K. a-Helix 2 in the amino-terminal Mad homology 1 domain is responsible for specific DNA-binding of Smad3. *J. Biol. Chem.* 276, 28155-28163, 2001.
 - 44.* Hanyu, A., Ishidou, Y., Ebisawa, T., Shimanuki, T., Imamura, T., and Miyazono, K. The N-domain of Smad7 is essential for specific inhibition of transforming growth factor- β signaling. *J. Cell Biol.* 155, 1017-1028, 2001.
 45. Yagi, K., Furuhashi, M., Aoki, H., Goto, D., Kuwano, H., Sugamura, K., Miyazono, K., and Kato, M. c-myc is a downstream target of Smad pathway. *J. Biol. Chem.* 277, 854-861, 2002.
 46. Ring, C., Ogata, S., Meek, L., Song, J., Ohta, T., Miyazono, K., and Cho, K.W.Y. The role of a Williams-Beuren syndrome-associated helix-loop-helix domain-containing transcription factor in activin/nodal signaling. *Genes Dev.* 16, 820-835, 2002.
 47. Nishihara, N., Watabe, T., Imamura, T., and Miyazono, K. Functional heterogeneity of BMPR-II mutants found in patients with primary pulmonary hypertension. *Mol. Biol. Cell* 22, 5212-5221, 2002.
 48. Suzuki, C., Murakami, G., Fukuchi, M., Shimanuki, T., Shikauchi, Y., Imamura, T., and Miyazono, K. (2002) Smurf1 regulates the inhibitory activity of Smad7 by targeting Smad7 to the plasma membrane. *J. Biol. Chem.* in press.
 49. Hamamoto, T., Beppu, H., Okada, H., Kawabata, M., Kitamura, T., Miyazono, K., and Kato, M. (2002) Compound disruption of *Smad2* accelerates malignant progression of intestinal tumors in *Apc* knockout mice. *Cancer Res.* in press.
 50. Miyazono, K., and Miyazawa, K. (2002) Id: A target of BMP signaling. *Science's STKE* in press.

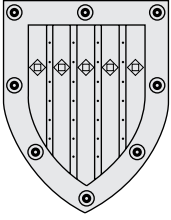

Department of Microbiology

Outline and Research Objectives

Microbial disease has been recognized as the major threat to human health throughout the history. Despite the development of preventive and therapeutic interventions against some pathogenic microbes, infectious disease is still one of the most significant medical problems. On the other hand, microbial organisms have served as a useful model as well for elucidating the human molecular mechanisms of a variety of biological events, providing useful insights into life science. Efforts have also been initiated by a number of research group to utilize animal viruses as a tool for human gene therapy. In order to familiarize students with these issues, importance of microbiology in medical education is increasing more rapidly than ever. To fulfill this requirement, our department, as the only basic microbiology unit in the Faculty and Graduate School, currently assumes a responsibility for teaching bacteriology and virology to medical undergraduates, and for educating graduate students in a field of virology on animal RNA viruses.

Our major research interest is to elucidate molecular mechanisms for species-, tissue-, and cell-specific pathogenicity of poliovirus and hepatitis C virus. For this purpose, we attempt to identify viral and host factors required for the viral replication and dissemination in animal model. Tissue and cell distribution of host factors in host species or animal model may give an insight into molecular pathogenesis of those RNA viruses. Thus, the main objectives in our department are as follows;

I. Replication, dissemination, and neurovirulence of poliovirus

Poliovirus (PV), the causative agent of poliomyelitis, is a human enterovirus that belongs to the Picornaviridae. The genome of PV is a single-stranded RNA of positive polarity and consists of approximately 7500 nucleotides (nt). To this RNA, a small protein VPg is attached at the 5' end, and poly(A) at the 3' end. PV mRNA does not have VPg and starts with simple pU. Thus PV mRNA is an exceptional eukaryotic mRNA. An internal ribosome entry site (IRES) was identified in the 5' untranslated region (UTR) of the RNA.

Natural PV infection in humans is thought to begin with oral ingestion. After ingestion, the virus multiplies in the alimentary mucosa; the tonsils and Peyer's patches are possibly also invaded early in the course of infection. Following multiplication in these loci, the virus moves into the deep cervical and mesenteric lymph nodes and then into the blood. Neutralizing antibodies to PV in the blood prevent the development of poliomyelitis, which suggests that viremia is necessary for the spread of virus to the central nervous system (CNS). The circulating virus then invades the CNS and replicates in neurons, particularly the motor neurons. There are two possible routes through which PV can enter the CNS. One is virus permeation through the blood-brain barrier (BBB) and the other is virus transmission via peripheral nerves. Paralytic poliomyelitis occurs as a result of neuronal destruction. Specifically, we are working on the following projects.

1. Roles of human PV receptor (hPVR) in PV infection.
2. Molecular mechanisms for BBB permeation of PV.
3. Molecular mechanisms for retrograde axonal transport of PV.
4. Replication of PV in neurons.

II. Replication and pathogenesis of hepatitis C virus

Hepatitis C virus (HCV), the main causative agent of non-A, non-B hepatitis, is a member of Flaviviridae. Chronic infection of HCV frequently leads to liver cirrhosis and hepatocellular carcinoma (HCC). The genome of HCV is a single-stranded RNA of positive polarity and consists of approximately 9500 nt. An IRES was found in the 5' portion of the HCV RNA like PV RNA, although it is not known whether the 5' end is capped or not. As for the 3'

UTR, the HCV RNA does not have a poly(A) tail but a poly(U/C) tract of 80-130 nt followed by a highly conserved 98 nt sequence among HCV isolates, termed the X region. Thus, HCV RNA has a unique structure as an eukaryotic mRNA. Specifically, we are working on the following projects.

1. Molecular mechanisms for development of HCC by HCV infection.
2. Replication mechanisms of HCV RNA replicon.

III. IRES-dependent virus tropism

Virulent strains of PV can replicate well both in the CNS and the alimentary mucosa, whereas attenuated strains of PV cannot replicate well in the CNS although these strains have a strong replicating capacity in the alimentary mucosa. Therefore, virulent and attenuated PV strains have different tissue tropism each other. Relatively strong determinant for the attenuation phenotype was identified in the 5' UTR within the IRES. It is possible that IRES activity differ in tissues, and that viral replication capacity reflects the IRES activity.

IRES was first described for picornavirus RNAs, and later for many cellular mRNAs as well as other viral RNAs. Nucleotide sequences that serve as IRES, so far discovered, have a variety of lengths and predicted secondary structures, although all of them have a similar function in translation initiation. Existence of a variety of IRES structures suggests that different sets of trans-acting cellular factors are required for activity of individual IRESs. Cumulative evidence suggests that cellular factors required for IRES activities are quantitatively and/or qualitatively different in individual IRESs. Specifically, we are working on the following projects.

1. Construction of recombinant viruses that have mutated IRESs.
2. Identification of host factors required for activity of various IRESs.
3. Establishment of method for measuring IRES activity in vivo.

Faculties and Students

Professor and Chair	Akio Nomoto, Ph.D. (since 1999)
Associate Professor	Tetsuro Matano, M.D., Ph.D.
Associate	2
Postdoctoral Fellow	3
Graduate Students	12
Secretary	2

Past Research and Major Accomplishments

1. Structural analysis of the 5' termini of all the PV specific RNAs and proposal of VPg-primer theory of PV RNA synthesis.
2. Determination of the primary structure of the genomes of all three attenuated PV serotypes
3. Construction of infectious cDNA clone of the attenuated PV strain (Sabin 1 strain) and first gene manipulation of animal RNA virus using the infectious clone.
4. Proposal of new copy choice model of RNA genome for its deletion and recombination events.
5. Molecular genetic analysis of the attenuation phenotype of type 1 PV.
6. Construction of new attenuated PV strains based on knowledge of stability of attenuation mutations.
7. Discovery of hPVR.

8. Establishment of hPVR/transgenic (Tg) mice susceptible to PV.
9. Analysis of interaction between PV and hPVR.
10. Formation of a concept "IRES-dependent virus tropism".
11. Study on dissemination pathway of PV using Tg mouse model.
12. Subcellular localization of hPVR in polarized cells.
13. Response of neural cells to poliovirus infection.
14. Discovery of HCV IRES

Current Research

1. There are two isoforms of functional human PV receptors, hPVR α and hPVR δ . These two isoforms differ only in a part of amino acid sequence within the cytoplasmic domain. Basolateral sorting signal was identified in the cytoplasmic domain of hPVR α but not hPVR δ . Indeed, hPVR α localizes to the basolateral membrane and hPVR δ apical membrane. It is possible that PV infection occurs by using hPVR δ in the human alimentary tract.
2. Using a hPVR/Tg mouse model, we have shown that PV permeates the BBB at a fairly high rate, independently of the presence of hPVR or virus strain-specific effects. Thus, some host cell molecules other than hPVR must be involved in the BBB permeability of PV. We are currently investi-

gating which host molecules are involved in this dissemination process.

3. Our recent results strongly suggest the following; Intramuscularly inoculated PV is incorporated by hPVR-mediated endocytosis at synapses without conformational change. The endosomes containing PV is associated with dynein motor molecule, and retrogradely transported to neuron cell body along microtubules. After the retrograde transport through the axon, lytic replication of PV occurs in the cell body. The virulent and attenuated PV strains do not show significant difference in efficiency of this dissemination route in a hPVR/Tg mouse model. We are attempting to prove the above hypothesis.
4. PV-infected neural cells do not show cytopathic effect when the infected cell cultures are added with anti-PV or anti-PVR antibodies 2 hours after the infection. Similar phenomenon cannot be observed in PV-infected HeLa cells. We precisely analyzed this phenomenon, and found that PV IRES activity was inhibited in the infected neural cells, and that PV-specific 2A protease was transported to the nucleus, and therefore translation initiation factor eIF4G was restored in the infected cells. We are currently attempting to elucidate why PV IRES activity is inhibited in the infected neural cells.
5. Development of cancers always accompanies mutations in chromosomes. Although HCV genome does not have any specific tumor gene, it is possible that some HCV gene products induce instability of human chromosome structure. We found that nuclear transport system was disturbed by HCV core protein. This may result in instability of human chromosome structure in the HCV-infected hepatocytes. We are now investigating interaction between HCV core protein and nuclear transport receptors.
6. Chimeric PV whose IRES was replaced by HCV IRES was constructed. This recombinant virus can replicate well in the liver of hPVR/Tg mice but not in the brain of the mice. This indicates that HCV IRES is active in the liver but not in the brain. The results support our notion "IRES-dependent virus tropism".

Future Prospects

PV is now one of the most well characterized virus and recent studies of its molecular biology have made great progress. Additionally, the development of a transgenic mouse model for poliomyelitis has not only facilitated investigations of PV dissemination but has transformed PV research into an important area of neuroscience. The elucidation of the molecular basis

of PV neurovirulence is only at its starting point, and some basic questions proposed in section of "Current Research" must be answered if we are to understand fully the molecular mechanisms responsible. This research could eventually lead to the development of new strategies to control poliomyelitis and other viral diseases.

It is an important question in life science why viruses without tumor gene are able to cause cancers. Extensive effort have been made to elucidate mechanisms for development of HCC by HCV infection. However, little is known, as yet, about the mechanisms responsible. Since development of effective vaccine to control HCV infection seems to be difficult, and altogether may be impossible, only sure way to control HCV is to elucidate molecular mechanisms responsible for onset of HCV disease, resulting in the development of new strategies to control the viral disease.

Our approach to study pathogenicity of RNA viruses may also provide useful insights into general life sciences.

Research Grants

- 1995-1999 Grant-in-aid for Specially Promoted Research (total ¥273,000,000)
- 2000-2004 Grant-in-aid for Specially Promoted Research (~2002 ¥182,000,000)
- 2001-2005 Research Grant from the Organization for Pharmaceutical Safety and Research (~2002 ¥65,000,000)

Select Publications

1. Akio Nomoto, Yuan Fon Lee & Eckard Wimmer. The 5' end of poliovirus mRNA is not capped with m7G(5')ppp(5')Np. *Proc. Natl. Acad. Sci. USA* 73: 375-380, 1976
2. Yuan Fon Lee, Akio Nomoto, Barbara M. Detjen & Eckard Wimmer. A protein covalently linked to poliovirus genome RNA. *Proc. Natl. Acad. Sci. USA* 74(1): 59-63, 1977
3. Akio Nomoto, Barbara M. Detjen, Rudy Pozzatti & Eckard Wimmer. The location of the polio genome protein in viral RNAs and its implication for RNA synthesis. *Nature* 268(5617): 208-213, 1977
4. Akio Nomoto, Naomi Kitamura, Fred Golini & Eckard Wimmer. The 5'-terminal structures of poliovirus RNA and poliovirus mRNA differ only in the genome-linked protein VPg. *Proc. Natl. Acad. Sci. USA* 72(12): 5345-5349, 1977
5. Akio Nomoto, Ann Jacobson, Yuan Fon Lee, John Dunn & Eckard Wimmer. Defective interfering particles of poliovirus: Mapping of the deletion and evi-

- dence that the deletions in the genomes of DI (1), (2) and (3) are located in the same region.
J. Mol. Biol. 128(2): 179-196, 1979
6. Akio Nomoto, Toshiko Omata, Haruka Toyoda, Shusuke Kuge, Hitoshi Horie, Yutaka Kataoka, Yuko Genba, Yasuko Nakano & Nobumasa Imura. Complete nucleotide sequence of the attenuated poliovirus Sabin 1 strain Genome.
Proc. Natl. Acad. Sci. USA 79(19): 5793-5797, 1982
 7. Haruka Toyoda, Michinori Kohara, Yutaka Kataoka, Toshiyuki Sukanuma, Toshiko Omata, Nobumasa Imura & Akio Nomoto. Complete nucleotide sequences of all three poliovirus serotype genomes: Implication for genetic relationship, gene function and antigenic determinants.
J. Mol. Biol. 174(4): 561-585, 1984
 8. Toshiko Omata, Michinori Kohara, Yuko Sakai, Atsuko Kameda, Nobumasa Imura & Akio Nomoto. Cloned infectious complementary DNA of poliovirus Sabin 1 genome: biochemical and biological properties of the recovered virus.
Gene 32 (Part I): 1-10, 1984
 9. Michinori Kohara, Toshiko Omata, Atsuko Kameda, Bert L. Semler, Heihachi Itoh, Eckard Wimmer & Akio Nomoto. In vitro phenotypic markers of a poliovirus recombinant constructed from infectious cDNA clones of the neurovirulent Mahoney and attenuated Sabin 1 strains.
J. Virol. 53(3): 786-792, 1985
 10. Toshiko Omata, Michinori Kohara, Shusuke Kuge, Toshihiko Komatsu, Shinobu Abe, Bert L. Semler, Atsuko Kameda, Heihachi Itoh, Mineo Arita, Eckard Wimmer & Akio Nomoto. Genetic analysis of the attenuation phenotype of poliovirus type 1.
J. Virol. 58(2): 348-358, 1986
 11. Michinori Kohara, Shinobu Abe, Shusuke Kuge, Bert L. Semler, Toshihiko Komatsu, Mineo Arita, Heihachi Itoh & Akio Nomoto. An infectious cDNA clone of the poliovirus Sabin strain could be used as a stable repository and inoculum for the oral polio live vaccine.
Virology 151(1): 21-30, 1986
 12. Shusuke Kuge, Izumu Saito & Akio Nomoto. Primary structure of poliovirus defective interfering particle genomes and possible generation mechanisms of the particle.
J. Mol. Biol. 192: 473-487, 1986
 13. Shusuke Kuge & Akio Nomoto. Construction of viable deletion and insertion mutants of the Sabin strain of type 1 poliovirus: Function of the 5' noncoding sequence in viral replication.
J. Virol. 61(5): 1478-1487, 1987
 14. Akio Nomoto, Narushi Iizuka, Michinori Kohara & Mineo Arita. Strategy for construction of live picornavirus vaccines.
Vaccine 6(2): 134-137, 1988
 15. Michinori Kohara, Shinobu Abe, Toshihiko Komatsu, Katsuhiko Tago, Mineo Arita & Akio Nomoto. A recombinant virus between the Sabin 1 and Sabin 3 vaccine strains of poliovirus as a possible candidate for a new type 3 poliovirus live vaccine strain.
J. Virol. 62(8): 2828-2835, 1988
 16. Shusuke Kuge, Noriyuki Kawamura & Akio Nomoto. Genetic variation occurring on the genome of an in vitro insertion mutant of poliovirus type 1.
J. Virol. 63(3): 1069-1075, 1989
 17. Noriyuki Kawamura, Michinori Kohara, Shinobu Abe, Toshihiko Komatsu, Katsuhiko Tago, Mineo Arita & Akio Nomoto. Determinants in the 5' noncoding region of poliovirus Sabin 1 RNA that influence the attenuation phenotype.
J. Virol. 63(3): 1302-1309, 1989
 18. Shusuke Kuge, Noriyuki Kawamura & Akio Nomoto. Strong inclination toward transition mutation in nucleotide substitutions by poliovirus replicase.
J. Mol. Biol. 207(1): 175-182, 1989
 19. Narushi Iizuka, Michinori Kohara, Kimiko Hagino-Yamagishi, Shinobu Abe, Toshihiko Komatsu, Katsuhiko Tago, Mineo Arita & Akio Nomoto. Construction of less neurovirulent polioviruses by introducing deletions into the 5' noncoding sequence of the genome.
J. Virol. 63(12): 5354-5363, 1989
 20. Kimiko Hagino-Yamagishi & Akio Nomoto. In vitro construction of poliovirus defective-interfering particles.
J. Virol. 63(12): 5386-5392, 1989
 21. Satoshi Koike, Hitoshi Horie, Iku Ise, Akira Okitsu, Michihiro Yoshida, Narushi Iizuka, Kenji Takeuchi Tsutomu Takegami & Akio Nomoto. The poliovirus receptor protein is produced both as membrane-bound and secreted forms.
EMBO J. 9(10): 3217-3224, 1990
 22. Satoshi Koike, Choji Taya, Takeshi Kurata, Shinobu Abe, Iku Ise, Hiromichi Yonekawa & Akio Nomoto. Transgenic mice susceptible to poliovirus.
Proc. Natl. Acad. Sci. USA 88(3): 951-955, 1991
 23. Kyoko Tsukiyama-Kohara, Michinori Kohara, Kenjiro Yamaguchi, Noboru Maki, Ayumi Toyoshima, Keizaburo Miki, Satoshi Tanaka, Nobu Hattori & Akio Nomoto. A second group of hepatitis C virus.
Virus Genes 5(3): 243-254, 1991
 24. Satoshi Koike, Iku Ise & Akio Nomoto. Functional domains of the poliovirus receptor.
Proc. Natl. Acad. Sci. USA 88(5): 4104-4108, 1991
 25. Narushi Iizuka, Hiromichi Yonekawa & Akio Nomoto. Nucleotide sequences important for translation initiation of enterovirus RNA.
J. Virol. 65(9): 4867-4873, 1991
 26. Kyoko Tsukiyama-Kohara, Narushi Iizuka, Michinori Kohara & Akio Nomoto. Internal ribosome entry site within hepatitis C virus RNA.
J. Virol. 66(3): 1476-1483, 1992
 27. Satoshi Koike, Iku Ise, Yasuko Sato, Kotoko Mitsui, Hitoshi Horie, Hideaki Umeyama & Akio Nomoto. Early events of poliovirus infection.
Seminars in Virology, Vol.3, 1992, Cellular Receptors for Virus Infection (A. Nomoto, ed.) pp109-115, Saunders Scientific Publications/ Academic Press

28. Satoshi Koike, Iku Ise, Yasuko Sato, Hiromichi Yonekawa, Osamu Gotoh & Akio Nomoto. A second gene for African green monkey poliovirus receptor that has no putative N-glycosylation site in the functional N-terminal immunoglobulin-like domain. *J. Virol.* 66(12): 7059-7066, 1992
29. Akio Nomoto. Recombinant polioviruses as candidates for oral poliovaccines. *Microbiol. Immunol.* 37(3): 169-174, 1993
30. Akio Nomoto, Satoshi Koike & Junken Aoki. Tissue tropism and species specificity of poliovirus infection. *Trends in Microbiology*, Vol. 2, No.2, 47-51, 1994
31. Hitoshi Horie, Satoshi Koike, Takeshi Kurata, Yasuko Sato-Yoshida, Iku Ise, Yoshihiro Ota, Shinobu Abe, Kyoji Hioki, Hideki Kato, Choji Taya, Tatsuji Nomura, Sou Hashizume, Hiromichi Yonekawa & Akio Nomoto. Transgenic mice carrying the human poliovirus receptor: new animal model for study of poliovirus neurovirulence. *J. Virol.* 68 (2): 681-688, 1994
32. Junken Aoki, Satoshi Koike, Iku Ise, Yasuko Sato-Yoshida & Akio Nomoto. Amino acid residues on human poliovirus receptor involved in interaction with poliovirus. *J. Biol. Chem.* 269 (11) : 8431-8438, 1994
33. Shinobu Abe, Yoshihiro Ota, Satoshi Koike, Takeshi Kurata, Hitoshi Horie, Tatsuji Nomura, So Hashizume & Akio Nomoto. Neurovirulence test for oral live poliovaccines using poliovirus-sensitive transgenic mice. *Virology* 206: 1075-1083, 1995
34. Kazuko Shiroki, Toshihiko Ishii, Takahiro Aoki, Yoshihiro Ohta, Wei-Xing Yang, Toshihiko Komatsu, Yasushi Ami, Mineo Arita, Shinobu Abe, So Hashizume & Akio Nomoto. Host range phenotype induced by mutations in the internal ribosomal entry site of poliovirus RNA. *J. Virol.* 71 (1): 1-8, 1997
35. Wei-Xing Yang, Tetsuya Terasaki, Kazuko Shiroki, Seii Ohka, Junken Aoki, Shuichi Tanabe, Tatsuji Nomura, Eiji Terada, Yuichi Sugiyama & Akio Nomoto. Efficient delivery of circulating poliovirus to the central nervous system independently of poliovirus receptor. *Virology* 229 (2): 421-428, 1997
36. Nobuhiko Kamoshita, Kyoko Tsukiyama-Kohara, Michinori Kohara & Akio Nomoto. Genetic analysis of internal ribosomal entry site on hepatitis C virus RNA: implication for involvement of the highly-ordered structure and cell type specific trans-acting factors. *Virology* 223 (1): 9-18, 1997
37. Junken Aoki, Satoshi Koike, Hiroaki Asou, Iku Ise, Hiroshi Suwa, Toshiyuki Tanaka, Masayuki Miyasaka & Akio Nomoto. Mouse homolog of poliovirus receptor-related gene 2 product, mPRR2, mediates cell aggregation. *Exp. Cell Res.* 235: 374-384, 1997
38. Minetaro Arita, Satoshi Koike, Junken Aoki, Hitoshi Horie & Akio Nomoto. Interaction of poliovirus with its purified receptor and conformational alteration in the virion. *J. Virol.* 72 (5): 3578-3586, 1998
39. Seii Ohka, Wei-Xing Yang, Eiji Terada, Kuniko Iwasaki & Akio Nomoto. Retrograde transport of intact poliovirus through the axon via the fast transport system. *Virology* 250 (1): 67-75, 1998
40. Minetaro Arita, Hitoshi Horie, Mineo Arita & Akio Nomoto. Interaction of poliovirus with its receptor affords a high level of infectivity to the virion in poliovirus infections mediated by the Fc receptor. *J. Virol.* 73(2): 1066-1074, 1999
41. Kazuko Shiroki, Takeshi Isoyama, Shusuke Kuge, Toshihiko Ishii, Shinobu Ohmi, Syoji Hata, Koichi Suzuki, Yoshinari Takasaki & Akio Nomoto. Intracellular redistribution of truncated La protein produced by poliovirus 3Cpro-mediated cleavage. *J. Virol.* 73(3): 2193-2200, 1999
42. Qingmei Jia, Seii Ohka, Kuniko Iwasaki & Akio Nomoto. Isolation and molecular characterization of a poliovirus type 1 mutant that replicates in the spinal cords of mice. *J. Virol.* 73(7): 6041-6047, 1999
43. Takeshi Isoyama, Nobuhiko Kamoshita, Kotaro Yasui, Atsushi Iwai, Kazuko Shiroki, Haruka Toyoda, Akio Yamada & Akio Nomoto. Lower concentration of La protein required for internal ribosome entry on hepatitis C virus than on poliovirus RNA. *J. Gen. Virol.* 80(9): 2319-2327, 1999
44. Kyoko Murakami, Michikazu Abe, Tsutomu Kageyama, Nobuhiko Kamoshita & Akio Nomoto. Down regulation of translation driven by hepatitis C virus internal ribosomal entry site by the 3' untranslated region of RNA. *Arch. Virol.* 146(4): 729-741, 2001
45. Qingmei Jia, James M. Hogle, Tsutomu Hashikawa & Akio Nomoto. Molecular genetic analysis of revertants from a poliovirus mutant that is specifically adapted to the spinal cord of mice. *J. Virol.*, 75(23): 11766-11772, 2001
46. Seii Ohka, Hitoshi Horie, Koujiro Tohyama & Akio Nomoto. Basolateral sorting of human poliovirus receptor involves an interaction with the m1B subunit of the clathrin adaptor complex in polarized epithelial cells. *Biochem. Biophys. Res. Comm.*, 287: 941-948, 2001
Seii Ohka & Akio Nomoto. Recent insights into poliovirus pathogenesis. *Trends in Microbiology*, 9(10): 501-506, 2001
48. Qingmei Jia, Fengyi Liang, Seii Ohka, Akio Nomoto & Tsutomu Hashikawa. Expression of brain-derived neurotrophic factor in the central nervous system of mice using a poliovirus-based vector. *J. NeuroVirology*, 8(1): 14-23, 2002
49. Akio Nomoto & Isao Arita. Eradication of Poliomyelitis. *Nature Immunology*, 3(3): 205-208, 2002

50. Takeshi Isoyama, Shusuke Kuge & Akio Nomoto.
The core protein of hepatitis C virus is imported into
the nucleus by transport receptor Kap123p but
inhibits Kap121p-dependent nuclear import of yeast-
AP1-like factor in yeast cells.
J. Biol. Chem., 277(42): 39634-39641, 2002
Publications indicated by bold letters are attached.

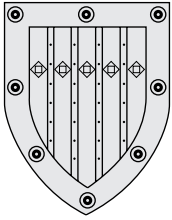

Department of Infection Control and Prevention

Outline and Research Objectives

The Department of Infection Control and Prevention was founded in 1994 in order to minimize hospital infections. This department is, therefore, very new, but is the oldest one in the field of infection control in Japan. It started at first as the Division of Hospital Infection and Control Services on January 23, 1991. This division developed into the Division of Infection Control and Prevention on September 1, 1993 and the present department on June 24, 1994.

Research and practice of hospital infection control in Japan has been very primitive, and at least 15-20 years behind those in USA and European countries. The main objectives of our department are: 1) to control and prevent hospital infections, 2) to develop and propagate new effective methods to control and prevent hospital infections and 3) to be a model and lead of infection control in Japan. Therefore, surveillance of hospital infections, early detection of outbreaks, analyses of the causes of outbreaks and intervention are the most important parts of our activities. Education of medical and comedical staffs and students is also a very important role of our department.

Faculties and Students

Professor and Chair	Satoshi Kimura, MD, PhD (1996~)
Lecturer (Hospital)	Kyoji Moriya, MD, PhD (2002~)
Associate (Hospital)2
Postdoctoral Fellow1
Research student2
Secretary2

Past Research and Major Accomplishments

1. Establishment of hospital infection surveillance system in the University of Tokyo Hospital (comprehensive and targeted).
2. Reduction of surgical site infections by replacing razor with clipper for preoperational removal of body hair at surgical sites.
3. Introduction of EPINet system into Japan and conduction of nationwide surveillance of needlestick injuries in health care workers in Japan.
4. Reduction of needlestick injuries among health care workers by employing safety devices.
5. Epidemiological analyses of Methicillin-resistant *Staphylococcus aureus* (MRSA) and other drug resistant microbes by using PFGE and/or PCR in the University of Tokyo Hospital.
6. Control of MRSA outbreak in NICU by unselected use of mupirocin ointment.
7. Control of *Ralstonia pickettii* colonization of patients in an obstetric ward.
8. Evaluation of disinfectant and antiseptics.
9. Nationwide surveillance of opportunistic infections in HIV infection.

10. Development of PCR systems for diagnosis of opportunistic infections in HIV/AIDS.
11. Quantitative analyses of cytomegalovirus (CMV) in the blood using real-time PCR for early diagnosis, monitoring and prospecting of CMV infections.
12. Evaluation of clinical efficacy of antiretroviral agents and highly active antiretroviral therapy (HAART).
13. Pharmacodynamic analyses of anti-HIV agents.
14. Evaluation of clinical significance of drug-resistance mutations of HIV against protease inhibitors.
15. Analyses of hospital visits among HIV-infected persons and AIDS cases in Japan.
16. Anti-HIV activities of oligodeoxyribonucleotides, ribozymes, fluoroquinolones etc..
17. Elucidation of molecular mechanism of viral hepatocarcinogenesis (HBV and HCV).
18. Elucidation of molecular mechanism of chemotaxis.
19. Elucidation of mode of action of defensin and cloning of a novel mouse β -defensin.
20. Establishment of certification system of Infection Control Doctors (ICD) in Japan by organizing Japanese Council of ICD consisting of 16 scientific societies in the field of infectious diseases.

Current Research

We have been mainly studying on following subjects:

1. Surveillance, analyses of hospital infections, and planning to reduce hospital infections and occupational infections, such as needle stick injuries.

2. Epidemiological analyses of methicillin-resistant *Staphylococcus aureus* and other drug-resistant microbes using PFGE, AP-PCR, etc.
3. Evaluation of disinfectants and antiseptics.
4. Development of sensitive and rapid methods to detect pathogens.
5. Evaluation of multiple-drug therapies for HIV infection.
6. Quantification of DNA viruses in the blood using real-time PCR.
7. Preparation of guideline for appropriate use of antimicrobials.
8. Molecular mechanism of viral hepatocarcinogenesis.

Future Prospect

Surveillance is most important for the analysis of causes of outbreaks, and for the development of new preventive measures. So far, we have established surveillance system in the University of Tokyo Hospital. ICD system established by Prof. S. Kimura in 1999 greatly stimulated the trend to start surveillance in many other hospitals all over Japan. Thus, level of infection control and prevention in Japan will be rapidly elevated. In this process, staffs in our department will gain initiative.

By reducing hospital infections, duration of hospital stay of patients is to be shortened, medical expense be reduced, prognosis of patients be better, and quality of life be improved.

Research Grants

1. 1998 : Grant-in-Aid from the Ministry of Health and Welfare of Japan (H-9-AIDS-002) "Studies on HIV Infection" ¥216,400,000
2. Grant-in-Aid from the Ministry of Health and Welfare of Japan "Studies on Epidemiology of HIV" ¥500,000
3. Grant-in-Aid for International Medical Cooperation "Studies on International Medical Cooperation against HIV Pandemic" ¥22,000,000
4. Grant-in-Aid from the Organization for Pharmaceutical Safety and Research "Epidemiological and Clinical Studies on Complications of HIV Infections" ¥90,000,000
5. 1999 : Grant-in-Aid from the Ministry of Health and Welfare of Japan (H-9-AIDS-002) "Studies on HIV Infection" ¥216,426,000
6. Grant-in-Aid from the Ministry of Health and Welfare of Japan "Studies on Epidemiology of HIV" ¥500,000
7. Grant-in-Aid from the Organization for Pharmaceutical Safety and Research "Epidemiological and Clinical Studies on Complications of HIV Infections" ¥90,000,000

8. 2000 : Grant-in-Aid from the Ministry of Health, Labor and Welfare of Japan (H-12-AIDS-004) "Studies on the Management of Complication in HIV/AIDS" ¥70,000,000
9. Grant-in-Aid from the Ministry of Health, Labor and Welfare of Japan "Socio-epidemiological Studies on the Trends of HIV/AIDS in Japan and Its Intervention" ¥500,000
10. 2001 : Grant-in-Aid from the Ministry of Health, Labor and Welfare of Japan (H-12-AIDS-004) "Studies on the Management of Complication in HIV/AIDS" ¥1,005,000,000
11. Grant-in-Aid from the Ministry of Health, Labor and Welfare of Japan "Socio-epidemiological Studies on the Trends of HIV/AIDS in Japan and Its Intervention" ¥500,000
12. 2002 : Grant-in-Aid from the Ministry of Health, Labor and Welfare of Japan (H-12-AIDS-004) "Studies on the Management of Complication in HIV/AIDS" ¥63,000,000
13. Grant-in-Aid from the Ministry of Foreign Affairs of Japan, US-Japan Cooperative Medical Science Program AIDS Panel ¥6,500,000
14. Grant-in-Aid from the Ministry of Health, Labor and Welfare of Japan "Socio-epidemiological Studies on the Trends of HIV/AIDS in Japan and Its Intervention" ¥500,000

Select Publications

1. S. Kimura, J. Matsuda, S. Ikematsu, K. Miyazono, A. Ito, T. Nakahata, M. Minamitani, K. Shimada, Y. Shiokawa, and F. Takaku; Efficacy of recombinant human granulocyte colony-stimulating factor on neutropenia in patients with AIDS. *AIDS* 4: 1251-1255, 1990
2. S. Oka, K. Urayama, Y. Hirabayashi, K. Ohnishi, H. Goto, K. Mitamura, S. Kimura, and K. Shimada; Quantitative estimation of human immunodeficiency virus type-1 provirus in CD4+ T lymphocytes using the polymerase chain reaction. *Mol. and Cellular Probes* 5: 137-142, 1991
3. T. Toyoshima, S. Kimura, S. Muramatsu, H. Takahagi, and K. Shimada; A sensitive nonisotopic method for the determination of intracellular azidothymidine 5'-mono-, 5'-di-, and 5'-tri-phosphate. *Analyt. Biochem.* 196: 302-307, 1991
4. K. Kitada, S. Oka, S. Kimura, K. Shimada, T. Serikawa, J. Yamada, H. Tsunoo, K. Egawa, and Y. Nakamura; Detection of *Pneumocystis carinii* sequence by polymerase chain reaction: animal models and clinical application to noninvasive specimens. *J. Clin. Microbiol.* 29: 1985-1990, 1991
5. S. Oka, K. Urayama, Y. Hirabayashi, S. Kimura, K. Mitamura, and K. Shimada; Human immunodeficiency virus DNA copies as a virologic marker in a clinical trial with β -interferon. *J. Acquir. Immun. Def. Synd.* 5: 707-711, 1992

6. S. Kimura; Current state of AIDS treatment - Can AIDS be controlled? - . Asian Med. J. 35: 251-259, 1992
7. S. Kimura, S. Oka, T. Toyoshima, Y. Hirabayashi, Y. Kikuchi, K. Mitamura, and K. Shimada; A randomized trial of reduced doses of azidothymidine in Japanese patients with human immunodeficiency virus type 1 infection. Intern. Med. 31: 871-876, 1992
8. S. Oka, M. Goto, Y. Kaji, S. Kimura, K. Matsuda, Y. Asai, M. Sanada, S. Nakagawa, M. Inoue, and K. Shimada; Synergistic activity of imipenem/cilastatin combined with cefotiam against methicillin-resistant *Staphylococcus aureus*. J. Antimicrob. Chemother. 31: 533-541, 1993
9. K. Yamada, S. Kimura, M. Negishi, J. Takamatsu, M. Inagaki, M. Aihara, Y. Nishida, K. Mori, K. Fukutake, J. Mimaya, N. Takata, and K. Shimada. Phase I/II trial of didanosine (2', 3'-dideoxyinosine) in hemophilic patients with AIDS or AIDS-related complex. Clin. Diagnostic Virol. 1: 245-256, 1993
10. S. Oka, K. Kitada, T. Kohjin, Y. Nakamura, S. Kimura, and K. Shimada; Direct monitoring as well as sensitive diagnosis of *Pneumocystis carinii* pneumonia by polymerase chain reaction on sputum samples. Mol. Cellular Probes 7: 419-424, 1993
11. J. Hoy, E. J. Wright, and S. Kimura; Early HIV infection. AIDS 8 (suppl 2): s29-s35, 1994
12. T. Shioda, S. Oka, S. Ida, K. Nokihara, H. Toriyoshi, S. Mori, Y. Takebe, S. Kimura, K. Shimada, and Y. Nagai; A naturally occurring single basic amino acid substitution in the V3 region of HIV-1 Env protein alters the viral cellular host range and antigenic structure. J. Virol. 68: 7689-7696, 1994
13. H. Furukawa, K. Momota, T. Agatsuma, I. Yamamoto, S. Kimura, and K. Shimada; Mechanism of inhibition of HIV-1 infection *in vitro* by guanine-rich oligonucleotides modified at the 5' terminal by dimethoxytrityl residue. Nucleic Acids Res. 22: 5621-5627, 1994
14. S. Watanabe, M. Shinkai, S. Hitomi, H. Kozuka, S. Kimura, K. Shimada, R. Hondo, and N. Yamaguchi; A polymorphic region of the human cytomegalovirus genome encoding putative glycoproteins. Arch. Virol. 137: 117-121, 1994
15. A. Yasuoka, S. Oka, K. Komuro, H. Shimizu, K. Kitada, S. Shibahara, T. Takeuchi, S. Kondo, K. Shimada, and S. Kimura; Successful treatment with Benanomycin A (ME1451) of *Pneumocystis carinii* pneumonia in mice. Antimicrobial Agents Chemother. 39: 720-724, 1995
16. A. Suzaki, M. Kimura, S. Kimura, K. Shimada, M. Miyaji, and L. Kaufman; An outbreak of histoplasmosis contacted by Japanese visitors to a bat-inhabited cave near Manaus, Brazil. J. Mycol. Med. 5: 40-43, 1995
17. M. Goto, S. Oka, N. Tachikawa, K. Kitada, M. Wada, C. Abe, K. Shimada, and S. Kimura; *KatG* sequence deletion is not the major cause of isoniazid resistance in Japanese and Yemei *Mycobacterium tuberculosis* isolates. Molecular and Cellular Probes 9: 433-439, 1995
18. A. Yasuoka, N. Tachikawa, K. Kaoru, S. Kimura, and S. Oka; (1-3) β -D-glucan as a quantitative serological marker for *Pneumocystis carinii* pneumonia. Clin. Diag. Lab. Immunol. 3: 197-199, 1996
19. H. Hotoda, K. Momota, H. Furukawa, T. Nakamura, and M. Kaneko S. Kimura and K. Shimada; Biologically active oligodeoxyribonucleotides- IV: Anti-HIV activity of TGGGAG having hydrophobic substituent at 5'-end via phosphodiester linkage. Nucleosides & Nucleotides, 15: 531-538, 1996
20. H. Shiga, T. Shioda, H. Tomiyama, Y. Takamiya, S. Oka, S. Kimura, Y. Yamaguchi, T. Gojoubori, H-G. Rammensee, K. Miwa, and M. Takiguchi; Identification of multiple HIV-1 cytotoxic T-cell epitopes presented by human leukocyte antigen B35 molecules. AIDS. 10: 1075-1083, 1996
21. S. Oka, Y. Nagata, Y. Fujino, A. Yasuoka, N. Tachikawa, K. Shimada, S. Kimura, A. Iwamoto, M. Mochizuki; CD8+ T lymphocytes in cytomegalovirus retinitis in a patient with AIDS. Brit. J. Ophthalmol. 80: 1108-1109, 1996
22. S. Kimura; Neurologic manifestations in human immunodeficiency virus infection/ acquired immunodeficiency syndrome (Editorial): Intrenal Medicine 36: 160-161, 1997
23. S. Ida, H. Gatanaga, T. Shioda, Y. Nagai, N. Kobayashi, K. Shimada, S. Kimura, A. Iwamoto, and S. Oka; HIV type 1 V3 variation dynamics *in vivo*: Long-term persistence of non-syncytium-inducing genotypes and transient presence of syncytium-inducing genotypes during the course of progressive AIDS. AIDS Research and Human Retroviruses 13: 1597-1609, 1997
24. K. Momota, H. Furukawa, S. Kimura, H. Hotoda, S. Oka, and K. Shimada; Antiviral and biological properties of dimethoxytrityl-linked guanine-rich oligodeoxynucleotides that inhibit replication by primary clinical human immunodeficiency virus type-1 isolates. Antiviral Chem. Chemother. : 8: 497-505, 1997
25. H. Yotsuyanagi, K. Yasuda, S. Iino, K. Moriya, Y. Shintani, H. Fujie, T. Tsutsumi, S. Kimura, and K. Koike; Persistent viremia after recovery from self-limited acute hepatitis B. Hepatology 27: 1377-1382, 1998
26. K. Moriya, H. Fujie, Y. Shintani, H. Yotsuyanagi, T. Tsutsumi, K. Ishibashi, Y. Matsuura, S. Kimura, T. Miyamura and K. Koike; The core protein of hepatitis C virus induces hepatocellular carcinoma in transgenic mice. Nature Medicine, 4 (9): 1065-1067, 1998.
27. S. Hitomi, S. Baba, H. Yano, Y. Morisawa and S. Kimura; Antimicrobial effects of electrolytic products of sodium chloride - Comparative evaluation with sodium hypochlorite solution and efficacy in hand-washing. J. Jpn. Assoc. Infect. Dis. 72 (11): 1176-1181, 1998
28. K. Koike, K. Moriya, H. Yotsuyanagi, Y. Shintani, H. Fujie, T. Tsutsumi, and S. Kimura; Compensatory

- apoptosis in preneoplastic liver of a transgenic mouse model for viral hepatocarcinogenesis. *Cancer Lett* 134 (2): 181-186, 1998
29. M. Koizumi, Y. Ozawa, R. Yagi, T. Nishigaki, M. Kaneko, S. Oka, S. Kimura, A. Iwamoto, Y. Komatsu, and E. Otsuka; Design and anti-HIV-1 activity of hammerhead and hairpin ribozymes containing a stable loop. *Nucleosides & Nucleotides* 17 (1-3) : 207-218, 1998
 30. H. Kashiwase, K. Momota, T. Ohmine, T. Komai, T. Kimura, T. Katube, T. Nishigaki, S. Kimura, K. Shimada and H. Furukawa; A new fluoroquinolone derivative exhibits inhibitory activity against human immunodeficiency virus type 1 replication. *Chemotherapy* 45: 48-55, 1999
 31. N. Tachikawa, M. Goto, Y. Hoshino, H. Gatanaga, A. Yasuoka, T. Wakabayashi, Y. Katano, S. Kimura, S. Oka, and A. Iwamoto; PCR detects *Toxoplasma gondii*, Epstein-Barr virus, and JC virus DNAs in the cerebrospinal fluid in AIDS patients with focal CNS complications. *Intern. Med.* 38: 556-562, 1999
 32. H. Fujie, H. Yotsuyanagi, K. Moriya, Y. Shintani, T. Tsutsumi, T. Takayama, M. Makuuchi, Y. Matsuura, T. Miyamura, S. Kimura, and K. Koike; Steatosis and intrahepatic hepatitis C virus in chronic hepatitis. *J. Med. Virol.* 59: 141-145, 1999
 33. Y. Shintani, H. Yotsuyanagi, K. Moriya, H. Fujie, T. Tsutsumi, Y. Kanegae, S. Kimura, I. Saito, and K. Koike; Induction of apoptosis upon the switch-on of the hepatitis B virus X gene mediated by Cre/loxP recombinase system. *J. Gen. Virol.* 180: 3257-3266, 1999
 34. E. Noiri, T. Yokomizo, A. Nakao, T. Izumi, T. Fujita, S. Kimura, and T. Shimizu; An *in vivo* approach showing the chemotactic activity of leukotriene B4 in acute renal ischemic-reperfusion injury. *Proc. Natl. Acad. Sci.* 97 (2): 823-828, 2000
 35. S. Hashimoto, T. Matsumoto, M. Nagai, Y. Matsuyama, Y. Nakamura, T. Umeda, M. Kamakura, S. Ichikawa, S. Kimura, K. Fukutomi, and M. Kihara; Delays and continuation of hospital visits among HIV-infected persons and AIDS cases in Japan. *J. Epidemiol.* 10 (1): 65-70, 2000
 36. Y. Shintani, H. Yotsuyanagi, K. Moriya, H. Fujie, T. Tsutsumi, T. Takayama, M. Makuuchi, S. Kimura, and K. Koike; The significance of hepatitis B virus DNA detected in hepatocellular carcinoma of patients with hepatitis C. *Cancer* 88 (11): 2479-2486, 2000
 37. U. Machida, M. Kami, T. Fukui, Y. Kazuyama, M. Kinoshita, Y. Tanaka, Y. Kanda, S. Ogawa, H. Honda, S. Chiba, K. Mitani, Y. Muto, K. Osumi, S. Kimura, and H. Hirai; Real-time automated PCR for early diagnosis and monitoring of cytomegalovirus infection after bone marrow transplantation. *J. Clin. Microbiol.* 38 (7): 2536-2542, 2000
 38. A. Yoneyama, H. Yano, S. Hitomi, K. Okuzumi, R. Suzuki, and S. Kimura; *Ralstonia pickettii* colonization of patients in an obstetric ward caused by a contaminated irrigation system. *J. Hosp. Infection* 46: 77-80, 2000
 39. S. Hitomi, M. Kubota, N. Mori, S. Baba, H. Yano, K. Okuzumi, and S. Kimura; Control of a methicillin-resistant *Staphylococcus aureus* outbreak in a neonatal intensive care unit by unselective use of nasal mupirocin ointment. *J. Hosp. Infection* 46: 123-129, 2000
 40. H. Yotsuyanagi, Y. Shintani, K. Moriya, H. Fujie, T. Tsutsumi, T. Kato, K. Nishioka, T. Takayama, M. Makuuchi, S. Iino, S. Kimura, and K. Koike; Virologic analysis of non-B, non-C hepatocellular carcinoma in Japan: frequent involvement of hepatitis B virus. *J. Infect. Dis.* 181: 1920-8, 2000
 41. E. Noiri, A. Nakao, A. Oya, T. Fujita, and S. Kimura; Hepatitis C virus in blood and dialysate in hemodialysis. *Am. J. Kidney Dis.* 37 (1): 38-42, 2001
 42. H. Fujie, K. Moriya, Y. Shintani, H. Yotsuyanagi, S. Iino, S. Kimura, and K. Koike; Hepatitis B virus genotypes and hepatocellular carcinoma in Japan. *Gastroenterology* 120: 1564-1565, 2001
 43. K. Tsuchiya, S. Matsuoka, A. Hachiya, A. Yasuoka, N. Tachikawa, Y. Kikuchi, I. Genka, K. Teruya, S. Kimura and S. Oka; Accumulation of lopinavir resistance-associated mutations over 3 years follow-up of patients on highly active antiretroviral therapy: implication in salvage therapy. *AIDS* 15 (9): 1183-1184, 2001
 44. H. Fujie, K. Moriya, Y. Shintani, T. Tsutsumi, T. Takayama, M. Makuuchi, S. Kimura and K. Koike; Frequent β -catenin aberration in human hepatocellular carcinoma. *Hepatology Research* 20: 39-51, 2001
 45. K. Moriya, K. Nakagawa, T. Santa, Y. Shintani, H. Fujie, H. Miyoshi, T. Tsutsumi, T. Miyazawa, K. Ishibashi, T. Horie, K. Imai, T. Todoroki, S. Kimura and K. Koike; Oxidative stress in the absence of inflammation in a mouse model for hepatitis C virus-associated hepatocarcinogenesis. *Cancer Res.* 61: 4365-4370, 2001
 46. Y. Yamaguchi, S. Fukuhara, T. Nagase, T. Tomita, S. Hitomi, S. Kimura, H. Kurihara and Y. Ouchi; A novel mouse β -defensin, mBD-6, predominantly expressed in skeletal muscle. *J. Biol. Chem.* 276 (34): 31510-31514, 2001
 47. A. Yoshida, S. Hitomi, T. Fukui, H. Endo, Y. Morisawa, Y. Kazuyama, K. Osumi, S. Oka and S. Kimura; Diagnosis and monitoring of human cytomegalovirus diseases in patients with human immunodeficiency virus infection by use of a real-time PCR assay. *Clinical Infectious Diseases* 33: 1756-1761, 2001
 48. M. Tanaka, C. Yasuoka, I. Genka, N. Tachikawa, Y. Kikuchi, K. Teruya, A. Yasuoka, Y. Hirabayashi, S. Kimura and S. Oka; Sustained cytomegalovirus-specific CD4+ T cell response associated with prevention of recurrence of cytomegalovirus retinitis without secondary prophylaxis after highly active antiretroviral therapy in patients with AIDS. *AIDS Res. Human Retroviruses* 17 (18): 1749-1756, 2001

49. S. Ida, N. Tachikawa, A. Nakajima, M. Daikoku, M. Yano, Y. Kikuchi, A. Yasuoka, S. Kimura and S. Oka; Influence of human immunodeficiency virus type 1 infection on acute hepatitis A virus infection. *Clinical Infectious Diseases* 34, 379-85, 2002
50. K. Koike, K. Moriya and S. Kimura; Role of hepatitis C virus in the development of hepatocellular carcinoma: Transgenic approach to viral hepatocarcinogenesis. *J. Gastroenterol. Hepatol.* 17: 394-400, 2002

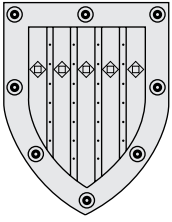

Department of Immunology

Outline and Research Objectives

Research projects, currently being conducted in our Department, have stemmed from the original identification of two cytokine genes between the late 1970s and early 1980s, namely, the genes encoding human fibroblast interferon (renamed thereafter as IFN- β) and interleukin-2 (IL-2), and their molecular characterization. In fact, the molecular distinction and consolidation of an enormous number of cytokine molecules, which are usually produced simultaneously at low levels in many cell types, have made it possible to study each cytokine as a single molecule and to elucidate their intracellular signaling mechanisms as well as their gene regulation mechanisms.

Given the fact that these cytokines are intimately involved in the regulation of immunity and oncogenesis, the above initial studies have led us to further extend the characterization of these cytokine systems in the context of the regulation of immune responses and oncogenesis. More recently, we have also initiated a project linking the immune system and bone remodeling in the context of cytokine signaling cross talk. Thus, our current research objectives are aimed at clarifying the following.

1. The mechanisms of signaling and transcription networks operating in the IFN- α/β system in innate immune responses.
2. The function and regulation of the transcription factor family, i.e., the interferon regulatory factors (IRFs), in innate and adaptive immune responses.
3. The mechanisms of regulation of antigen-presenting cells (APCs), typically dendrite cells (DCs), by IFNs and other cytokines and toll-like receptors (TLRs).
4. The regulation of ontogenesis by IFN- α/β and the tumor suppressor p53, particularly their mutual cooperation and function on target genes.
5. The regulation of bone remodeling by RANKL of the TNF family member and its signaling cross talks with IFNs and other cytokines.

The above projects are being conducted in a coordinated manner with much emphasis on interaction with researchers and students inside and outside of the Department, and collaborations, including international ones, are highly encouraged. The important objectives of our Department include the fostering of independent scientists with international experience, and search for new concepts critical for future developments in immunology and cancer biology.

Faculties and Students

Professor and Chair	Tadatsugu Taniguchi, Ph.D. (1995~)
Lecturer	Akinori Takaoka, M.D., Ph.D. (2000~)
Associate	2
Postdoctoral Fellow	4
Graduate student	12
Research student.....	1
Technical Assistant	2
Secretary	2

Past Research and Major Accomplishments

T. Taniguchi, Professor and Chairman of this Department, obtained his Ph. D. at the University of Zurich in 1978 (Title of doctoral dissertation: RNA-RNA interactions in the process of 70S initiation com-

plex formation between *E. coli* ribosomes and bacteriophage Q β RNA), and returned to work at The Cancer Institute, Japanese Foundation for Cancer Research in Tokyo, wherein the molecular characterization of soluble mediators of the immune response, now collectively termed cytokines, was initiated. In fact, we initially identified and characterized the genes encoding IFN- β and IL-2, and established the production of cytokines by recombinant DNA technology (Refs 1-6). The subsequent characterizations of the promoters of these genes, performed at the institute, were further extended after we moved to the Institute for Molecular and Cellular Biology of Osaka University, and we identified distinct regulatory *cis*-elements within the promoter of IFN- β gene, which function as a virus-inducible enhancer (Refs. 7, 12). The work on the IFN- β enhancer led us to the

discovery of a novel family of transcription factors, the IRF family, which now has nine members (Refs. 15, 18, 48). In fact, *IFN- α/β* genes as well as a number of IFN-inducible genes were shown to be involved in regulating cell proliferation and to be potential critical target genes of IRFs. We also identified the regulatory sequences of the *IL-2* gene, which have since been extensively studied in the context of T cell activation and anergy by many other groups (Ref. 9). We also continued working on the mechanisms of IL-2 signaling by characterizing and analyzing the structure and function of the IL-2 receptor complex. The achievements, made during and after transition to the current Department, are briefly summarized below on each project.

(1) Gene regulation in IFN- α/β system; Operation of “revving up” mechanism for robust antiviral responses.

The work on the *IFN- β* enhancer led us to discover the IRF family of transcription factors. A number of IFN-inducible genes were shown to be involved in regulating cell proliferation and to be potential critical target genes of IRFs (Ref. 48). In fact, to evaluate the diverse biological effect of IRFs in vivo, we initially established the mice deficient in *IRF-1* or *IRF-2* gene in collaboration with T. Mak and his colleagues, University of Toronto (Ref. 29). We first found that IRF-1 is a critical regulator for the antiviral response by IFNs, but that it is not essential for virus-induced *IFN- α/β* gene expression (Refs. 29, 31). More recently, we and others have focused on other two related IRF members, IRF-3 and IRF-7. These two factors reside in the cytoplasm of uninfected cells and undergo translocation to the nucleus after viral infection. We adduced experimental evidence that these two IRFs indeed activate the *IFN* promoters, and the exact role of these factors became clear when we generated mice deficient in these genes (Refs. 45, 48, 49). It was found that cells have an acquired auto-amplification mechanism for efficient *IFN- α/β* gene expression. Briefly, viral infections first result in the phosphorylation of the constitutively expressed IRF-3, and the phosphorylated IRF-3 primarily activates the *IFN- β* promoter. Once IFN- β is produced, it signals the cell to activate ISGF3, a heterotrimer complex consisting of STAT1, STAT2 and IRF-9; ISGF3 in turn induces *IRF-7* gene expression. The de novo produced IRF-7 then undergoes virus-induced phosphorylation, similar to IRF-3, and activates the *IFN- α/β* promoters. Thus, massive IFN- α/β production can be achieved through the positive-feedback loop (Refs. 48, 49).

We also found that the constitutive, IRF-3/IRF-7-independent production of IFN- α/β in uninfected cells is critical for setting the IRF-7 expression levels that determine whether or not the above-mentioned posi-

tive-feedback mechanism will operate effectively upon viral infection. We discussed the significance of spontaneous *IFN- α/β* gene expression, in the context of what we proposed as the “revving up” model. In fact, a weak IFN- α/β signaling also provides a foundation for cells to respond efficiently to other cytokines, such as IFN- γ and IL-6 (Ref. 49). In the “revving up” by the IFN- α/β signal, signaling molecules remain constantly activated, albeit weakly, and the expression level of target genes such as IRF-7 (and probably many others) is maintained, thereby providing a foundation for more efficient signaling, either in that pathway or in different pathways. Thus, the consumption of cellular resources is not futile but a regulated “trade-off” to provide the cell with a greater dynamic range (signal-to-noise) in its response to stimuli (Ref. 49). It is likely that mechanisms similar to what we found in the context of the “revving up” model may be operational in other immune responses, since the immune system generally requires such mechanisms so as to render the operation against invading pathogens effective.

(2) Function of IRF-1 and IRF-2: Regulation of immunity and oncogenesis.

In continuation of our analysis of the *IRF-1*-deficient mice, we found that IRF-1 is absolutely required for Th1 type of CD4⁺ T cell responses and NK cell differentiation. In fact, IRF-1 is essential for the induction of IL-12 and inducible nitric oxide synthase, which are critical for the induction and effector phase of Th1 response, respectively, and it is also essential for IL-15 gene expression in stroma cells to induce NK cell development (Refs. 37, 38, 48). In addition, IRF-1 is found to be a tumor susceptibility gene. IRF-1 is required in the induction of apoptosis of oncogene-expressing fibroblasts and DNA-damaged, proliferating mature T cells (Refs. 35, 36, 42). In DNA-damaged fibroblasts, IRF-1 cooperates with p53 to induce cell cycle arrest by activating the *p21^{WAF1/CIP1}* gene. We have shown that the loss of *IRF-1* alleles *per se* has no effect on spontaneous tumor development in the mouse, but that it dramatically exacerbates previous tumor predispositions caused by the *c-Ha-ras* transgene or nullizygosity for *p53*. In addition, notable alterations in the tumor spectrum of *IRF-1*, *p53* double-deficient mice indicated that IRF-1 is not hypostatic to p53. We also adduced evidence that the loss-of-function mutation in the *IRF-1* gene may be involved in cancer development in humans (Ref. 42, 48). In continuation of this project, we attempted to isolate genes functioning downstream of IRF-1/p53, and identified a novel gene, *Noxa*. The *Noxa* gene encodes a BH3-only protein of the Bcl-2 family, and its expression is actually dependent on p53; it also induces apoptosis when it is overexpressed (Ref. 43).

Although IRF-2 was originally identified as a negative regulator of IRF-1, it has a unique function in negatively regulating IFN- α/β signaling. IRF-2 is a very stable nuclear factor that attenuates transcription by the IFN-activated ISGF3. Interestingly, IRF-2-deficient mice spontaneously develop an inflammatory skin disease, resembling psoriasis. CD8⁺ T cells appear to be involved in the pathogenesis of this condition, and CD8⁺ T cells from these mice are hyper-responsive to antigen stimulation *in vitro*, which is accompanied by a markedly upregulated expression of genes induced by IFN- α/β (Refs. 46, 48). Thus, IRF-2 is necessary for balancing the beneficial and harmful effects of the spontaneous IFN- α/β signaling, as described above.

(3) Characterization and functional studies on the IL-2 receptor complex.

The use of recombinant IL-2 made it possible to study this "T cell growth factor" in the context of regulation of intracellular signaling mechanisms. T. Waldmann and colleagues first discovered the IL-2 receptor, as an IL-2R α chain, and it turned out that the functional receptor consists of subunits (Refs. 28, 34). We then isolated the second chain, IL-2R β chain, and showed for the first time that this cytokine receptor, lacking any catalytic domains, can transmit the signals to the cell interior by recruiting non-receptor tyrosine kinases (Refs. 8, 10, 17, 19, 34). In addition, it was also shown that multiple signaling molecules are recruited to the receptor, which play distinct functions. It is now known that IL-2R consists of IL-2R α , β (termed c β) and γ (termed c γ) chains.

We also took an *in vivo* approach to study the distinct domains of the IL-2R β cytoplasmic region by introducing each mutant cDNA that lacked one of these domains into IL-2R β -deficient mice. We showed that the lack of the membrane-distal H-region, which mediates activation of STAT5/STAT3 transcription factors, selectively affects the development of natural killer (NK) cells and T cells bearing $\gamma\delta$ T cell receptors. In contrast, the A-region, which is located next to the H-region and mediates the activation of Src-family protein tyrosine kinases, contributes to the downregulation of the T cell proliferation function. The IL-2R β c null mutant mice develop severe autoimmune symptoms, but these are all suppressed following the expression of either of the mutant cDNAs (Ref. 40).

(4) Osteoimmunology: Signaling cross talks between IFNs and RANKL in bone remodeling.

The regulation of osteoclast differentiation is an aspect central to the understanding of the pathogenesis and the treatment of bone diseases such as autoimmune arthritis and osteoporosis. In fact, excessive signaling by RANKL, a TNF family member essential for osteoclastogenesis, may contribute to

such pathological conditions. We found unique signaling cross talks between RANKL and IFNs. We provided evidence that activated T cells maintain bone homeostasis by counterbalancing the action of RANKL through IFN- γ production. IFN- γ induces the rapid degradation of the RANK adapter protein, TRAF6, resulting in the strong inhibition of the RANKL-induced activation of NF- κ B and JNK (Ref. 47). This work was introduced as a new area of research called osteoimmunology [Arron, J. R. et al. *Nature*, 408, 535, 2000]. More recently, we also found that RANKL induces the IFN- β gene, but not IFN- α genes, in osteoclast precursor cells, and that IFN- β strongly inhibits osteoclast differentiation by interfering with the RANKL-induced c-Fos expression (Ref. 50). The series of *in vivo* experiments revealed that these two IFN-mediated regulatory mechanisms, distinct with one another, are both important to keep balancing the homeostatic bone resorption. Collectively, these studies revealed novel aspects of the two types of IFNs, beyond their original roles in immune response, and may offer a molecular basis for the treatment of bone diseases.

Current Research

As described above, we have gained new insight into the mechanisms of signaling and transcription networks operating in the IFN- α/β system in immune responses. The current research projects in our laboratory are summarized as follows:

1. Function and regulation of IRFs.

Still elusive is the mechanism(s) by which IRF-3 and IRF-7 are activated by viruses. We have been trying to identify a virus-activated kinase(s), which is responsible for this activation by taking a proteomics approach. We have identified several molecules that are associated with IRF-3, and these molecules are currently subjected to functional analyses to determine their involvement in IRF-3 regulation. We have generated IRF-7-deficient mice and are now confirming the role of IRF-7 in IFN- α/β gene induction in distinct cell populations, particularly, in bone marrow-derived cells, such as DCs. Our preliminary data indicate that germinal center formation is impaired in the mutant mice, and we are going to analyze the underlying mechanisms. The generation of IRF-3/IRF-7 double deficient mice is also under way. As for IRF-1, we have been working on the role of IRF-1 in CD4⁺ T cell differentiation, particularly the identification of the IRF-1 target genes.

2. Mechanisms of regulation of antigen-presenting cells (APCs), typically dendritic cells (DCs).

We found that the IFN- α/β system is critically

involved in DC maturation, which is induced by TLRs. We are currently studying the mechanism by which TLR expression is regulated by the IFN- α/β system. We are also working on the differentiation and maturation of DCs, which are found to be abnormal in *IRF-2*-deficient mice.

3. Regulation of oncogenesis by IFN- α/β and the tumor suppressor p53.

A critical function of p53 in tumor suppression is the induction of apoptosis in cells exposed to noxious stresses, such as DNA damage. We have previously shown that Noxa belongs to the BH3-only subfamily of the Bcl-2 family proteins and that Noxa overexpression causes apoptosis of some cells. More recently, we generated mice deficient in the *Noxa* gene or in both *Noxa* and *Bax* genes. In addition, we are continuously studying on the cooperation between IFN signaling and p53 pathways in relation to oncogenesis using mutant mice that are defective in some of these pathways.

4. Regulation of osteoclast differentiation.

During the differentiation process of hematopoietic stem cells to osteoclasts with bone-resorbing activity, transcription factors such as PU.1, c-Fos, NF- κ B, and MITF play a critical and specific role. To date, however, little is known about how RANKL, but not other cytokines that activate similar pathways, specifically induces the terminal differentiation of osteoclasts through a specific transcriptional program. Previous observations suggest that RANKL signaling activates an as yet unknown pathway(s) that specifically invokes the transcriptional program leading the cells to undergo terminal differentiation. To gain insight into the mechanism of the RANKL-specific induction of the osteoclast differentiation program, we took a genome-wide screening approach to identify genes specifically induced by RANKL, but not by IL-1, and came up with the NFATc1 transcription factor. We are currently analyzing the complex signaling and transcription networks in the RANKL-c-Fos/TRAF6-NFATc1 pathways to gain more insight into the differentiation programs.

Future Prospects

From the inception of the molecular analyses of the cytokine systems in the late 1970s, research projects in our laboratory have progressed and differentiated in many ways. This was natural and important for our laboratory, particularly in fostering the next-generation scientists who are independent and have international experience. In fact, more than ten former colleagues have been promoted to full professor in renowned universities. The discovery and func-

tional analyses of the IRF family of transcription factors provided new insight into the molecular mechanisms underlying the efficient induction of IFN- α/β genes, as well as the regulation of immune responses and oncogenesis. As for future prospects, it is important to elucidate the mechanisms of activation of these transcription factors in virus-infected cells. Considering the increasing interest in the IFN- α/β system induction by nonviral pathogens in antigen presenting cells, it will also be important to elucidate the role of IFNs and IRFs in linking the innate and adaptive immune systems. We are beginning to see a new link between IFN systems and p53, and this will hopefully reveal a new and interesting area of research in cancer biology. We also continue elucidating the RANKL-mediated mechanisms of bone remodeling. We hope that our studies will provide novel therapeutic strategies for controlling infectious and neoplastic diseases, as well as bone diseases. In fact, it is also our long-term goal to gain insight into the mechanisms of autoimmunity and tumor immunity, so as to provide a means for the treatment of these diseases.

Research Grants

1. A grant for Advanced Research on Cancer from the Ministry of Education, Culture, Sports, Science, and Technology of Japan (1998-to date)
2. The research for the Future Program (96L0037) from Japan Society for the Promotion of Sciences (1995-1999).
3. Human Frontier Science Program (1996-1998); In collaboration with Drs. D. Littman (USA), B. Malissen and O. Acuto (France)

Selected Papers (50)

1. Taniguchi, T., Sakai, M., Fujii-Kuriyama, Y., Muramatsu, M., Kobayashi, S. and Sudo, T. ; Construction and identification of a bacterial plasmid containing the human fibroblast interferon gene sequence. *Proc. Jpn. Acad.*, 55B, 464-469, 1979.
2. Taniguchi, T., Ohno, S., Fujii-Kuriyama, Y. and Muramatsu, M. ; The nucleotide sequence of human fibroblast interferon cDNA. *Gene*, 10, 11-15, 1980.
3. Taniguchi, T., Mantei, N., Schwarzstain, M., Nagata, S., Muramatsu, M. and Weissmann, C. ; Human leukocyte and fibroblast interferons are structurally related. *Nature*, 285, 547-549, 1980.
4. Ohno, S. and Taniguchi, T. ; Structure of a chromosomal gene for human interferon- β . *Proc. Natl. Acad. Sci. USA*, 78, 5305-5309, 1981.
5. Taniguchi, T., Matsui, H., Fujita, T., Takaoka, C., Kashima, N., Yoshimoto, R. and Hamuro, J. ; Structure and expression of a cloned cDNA for human interleukin-2. *Nature*, 302, 305-310, 1983.

6. Kashima, N., Nishi-Takaoka, C., Fujita, T., Taki, S., Yamada, G., Hamuro, J. and Taniguchi, T. ; Unique structure of murine interleukin-2 as deduced from cloned cDNAs. *Nature*, 313, 402-404, 1985.
7. Fujita, T., Ohno, S., Yasumitsu, H. and Taniguchi, T. ; Delimitation and properties of DNA sequences required for the regulated expression of human interferon- β gene. *Cell*, 41, 489-496, 1985.
8. Hatakeyama, M., Minamoto, S., Uchiyama, T., Hardy, R. R., Yamada, G. and Taniguchi, T. ; Reconstitution of functional receptor for human interleukin-2 in mouse cells. *Nature*, 318, 467-470, 1985.
9. Fujita, T., Shibuya, H., Ohashi, T., Yamanishi, K. and Taniguchi, T. ; Regulation of human interleukin-2 gene. : Functional DNA sequences in the 5' flanking region for the gene expression in activated T lymphocytes. *Cell*, 46, 401-407, 1986.
10. Taniguchi, T., Fujita, T., Hatakeyama, M., Mori, H., Matsui, H., Sato, T., Hamuro, J., Minamoto, S., Yamada, G. and Shibuya, H. ; Interleukin-2 and its receptor: Structure and functional expression of the genes. *Cold Spring Harbor Symp.*, LI, 577-586, 1986.
11. Maruyama, M., Shibuya, H., Harada, H., Hatakeyama, M., Seiki, M., Fujita, T., Inoue, J-I., Yoshida, M. and Taniguchi, T. ; Evidence for aberrant activation of the interleukin-2 autocrine loop by HTLV-1-encoded p40x and T3/Ti complex triggering. *Cell*, 48, 343-350, 1987.
12. Fujita, T., Shibuya, H., Hotta, H., Yamanishi, K. and Taniguchi, T. ; Interferon- β gene regulation: Tandemly repeated sequences of a synthetic 6bp oligomer function as a virus inducible enhancer. *Cell*, 49, 357-367, 1987.
13. Yamada, G., Kitamura, Y., Sonoda, H., Harada, H., Taki, S., Mulligan, R.C., Osawa, H., Diamantstein, T., Yokoyama, S. and Taniguchi, T. ; Retroviral expression of the human IL-2 gene in a murine T cell line results in cell growth autonomy and tumorigenicity. *EMBO J.*, 6, 2705-2709, 1987.
14. Taniguchi, T. ; Regulation of cytokine gene expression. *Annu. Rev. Immunol.*, 6, 439-464, 1988.
15. Miyamoto, M., Fujita, T., Kimura, Y., Maruyama, M., Harada, H., Sudo, Y., Miyata, T. and Taniguchi, T. ; Regulated expression of a gene encoding a nuclear factor, IRF-1, that specifically binds to IFN- β gene regulatory elements. *Cell*, 54, 903-913, 1988.
16. Fujita, T., Kimura, Y., Miyamoto, M., Barsoumian, E. L. and Taniguchi, T. ; Induction of endogenous IFN- α and IFN- β gene by a regulatory transcription factor, IRF-1. *Nature*, 337, 270-272, 1989.
17. Hatakeyama, M., Tsudo, M., Minamoto, S., Kono, T., Doi, T., Miyata, T., Miyasaka, M. and Taniguchi, T. ; Interleukin-2 receptor β chain gene: Generation of three receptor forms by cloned human α and β chain cDNA's. *Science*, 244, 551-556, 1989.
18. Harada, H., Fujita, T., Miyamoto, M., Kimura, Y., Maruyama, M., Furia, A., Miyata, T. and Taniguchi, T. ; Structurally similar but functionally distinct factors, IRF-1 and IRF-2, bind to the same regulatory elements of IFN and IFN-inducible genes. *Cell*, 58, 729-739, 1989.
19. Hatakeyama, M., Mori, H., Doi, T. and Taniguchi, T. ; A restricted cytoplasmic region of IL-2 receptor β chain is essential for growth signal transduction but not for ligand binding and internalization. *Cell*, 59, 837-845, 1989.
20. Taniguchi, T., Hatakeyama, M., Minamoto, S., Kono, T., Doi, T., Tsudo, M., Miyasaka, M. and Miyata, T. ; Interleukin-2 receptor β chain: Molecular cloning and functional expression of the human cDNA. *Cold Spring Harbor Symposia on Quantitative Biology*, Vol. LIV, 689-694, 1989.
21. Harada, H., Willison, K., Sakakibara, J., Miyamoto, M., Fujita, T. and Taniguchi, T. ; Absence of the type I IFN system in EC cells: Transcriptional activator (IRF-1) and repressor (IRF-2) genes are developmentally regulated. *Cell*, 63, 303-312, 1990.
22. Hatakeyama, M., Kono, T., Kobayashi, N., Kawahara, A., Levin, S. D., Perlmutter, R. M., and Taniguchi, T. ; Interaction of the IL-2 receptor with the src-family kinase p56lck: Identification of novel intermolecular association. *Science*, 252, 1523-1528, 1991.
23. Shibuya, H., Yoneyama, M., Ninomiya-Tsuji, J., Matsumoto, K., and Taniguchi, T. ; IL-2 and EGF receptors stimulate the hematopoietic cell cycle via different signaling pathways: Demonstration of a novel role for c-myc. *Cell*, 70, 57-67, 1992.
24. Minami, Y., Kono, T., Yamada, K., Kobayashi, N., Kawahara, A., Perlmutter, R. M., and Taniguchi, T. ; Association of p56lck with IL-2 receptor β chain is critical for the IL-2 induced activation of p56lck. *EMBO J.*, 12, 759-768, 1993.
25. Harada H., Kitagawa, M., Tanaka, N., Yamamoto, H., Harada, K., Ishihara, M., and Taniguchi, T. ; Anti-oncogenic and oncogenic potentials of interferon regulatory factors-1 and-2. *Science*, 259, 971-974, 1993.
26. Willman, C. L., Sever, C. E., Pallavicini, M. G., Harada, H., Tanaka, N., Slovak, M. L., Yamamoto, H., Harada, K., Meeker, T. C., List, A. F., and Taniguchi, T. ; Deletion of *IRF 1*, mapping to chromosome 5q31.1, in human leukemia and preleukemic myelodysplasia. *Science*, 259, 968-971, 1993.
27. Minami, Y., Kono, T., Miyazaki, T., and Taniguchi, T. ; The IL-2 receptor complex: Its structure, function, and target genes. *Annu. Rev. Immunol.*, 11, 245-267, 1993.
28. Taniguchi, T., and Minami, Y. ; The IL-2/IL-2 receptor system: A current overview. *Cell*, 73, 5-8, 1993.
29. Matsuyama, T., Kimura, T., Kitagawa, M., Pfeffer, K., Kawakami, T., Watanabe, N., K dig, M. T., Amakawa, R., Kishihara, K., Wakaeham, A., Potter, J., Furlonger, L. C., Narendran, A., Suzuki, H., Ohashi, P. S., Paige, J. C., Taniguchi, T. and Mak, T. W.; Targeted disruption of IRF-1 or IRF-2 results in abnormal type I IFN gene induction and aberrant lymphocyte development. *Cell*, 75, 83-97, 1993.
30. Tanaka, N., Ishihara, M., Kitagawa, M., Harada, H., Kimura, T., Matsuyama, T., Lamphier, M. S., Aizawa, S., Mak, T. W. and Taniguchi, T.; Cellular commit-

- ment to oncogene-induced transformation or apoptosis is dependent on the transcription factor IRF 1. *Cell*, 77, 829-839, 1994.
31. Kimura, T., Nakayama, K., Penninger, J., Kitagawa, M., Harada, H., Matsuyama, T., Tanaka, N., Kamijo, R., Vilcek, J., Mak, T. W., Taniguchi, T. ; Involvement of the IRF-1 transcription factor in antiviral responses to interferons. *Science*, 264, 1921-1924, 1994.
 32. Miyazaki, T., Kawahara, A., Fujii, H., Nakagawa, Y., Minami, Y., Liu, Z-J., Oishi, I., Silvennoinen, O., Witthuhn, B.A., Ihle, J.N., and Taniguchi, T. ; Functional activation of Jak 1 and Jak3 by selective association with IL-2 receptor subunits. *Science*, 266, 1045-1047, 1994.
 33. Minami, Y., Nakagawa, Y., Kawahara, A., Miyazaki, T., Sada, K., Yamamura, H. and Taniguchi, T. ; Protein tyrosine kinase Syk is associated with and activated by the IL-2 receptor, possible link with the c-myc induction pathway. *Immunity*, 2, 89-100, 1995.
 34. Taniguchi, T. ; Cytokine signaling through nonreceptor protein tyrosine kinases. *Science*, 268, 251-255, 1995.
 35. Tamura, T., Ishihara, M., Lamphire, M.S., Tanaka, N., Oishi, I., Aizawa, S., Matsuyama, T., Mak, T. W., Taki, S. and Taniguchi, T. ; An IRF-1-dependent pathway of DNA damage-induced apoptosis in mitogen-activated T lymphocytes. *Nature*, 376, 596-599, 1995.
 36. Tanaka, N., Ishihara, M., Lamphier, M., Nozawa, H., Matsuyama, T., Mak, T.W., Aizawa, S., Tokino, T., Oren, M. and Taniguchi, T. ; Cooperation of the tumor suppressors IRF-1 and p53 in response to DNA damage. *Nature*, 382, 816-818, 1996.
 37. Taki, S., Sato, T., Ogasawara, K., Fukuda, T., Sato, M., Hida, S., Suzuki, G., Mitsuyama, M., Shin, E.-H., Kojima, S., Taniguchi, T. and Asano, Y. ; Multistage regulation of Th1-type immune responses by the transcription factor IRF-1. *Immunity*, 6, 673-679, 1997.
 38. Ogasawara, K., Hida, S., Azimi, N., Tagaya, Y., Sato, T., Yokochi-Fukuda, T., Waldmann, T.A., Taniguchi, T. and Taki, S. ; Requirement of IRF-1 for the microenvironment supporting natural killer cell development. *Nature*, 391, 700-703, 1998.
 39. Miyazaki, T., Takaoka, A., Nogueira, L., Dikic, I., Fujii, H., Tsujino, S., Mitani, Y., Maeda, M., Schlessinger, J. and Taniguchi, T. ; Pyk2 is a downstream mediator of the IL-2 receptor-coupled Jak-signaling pathway. *Genes. Dev.* 12, 770-775, 1998.
 40. Fujii, H., Ogasawara, K., Otsuka, H., Suzuki, M., Yamamura, K., Yokochi, T., Miyazaki, T., Suzuki, H., Mak, T. W., Taki, S. and Taniguchi, T. ; Functional dissection of the cytoplasmic subregions of the IL-2 receptor β c chain in primary lymphocyte populations. *EMBO J.*, 17, 6551-6557, 1998.
 41. Takaoka, A., Tanaka, N., Mitani, Y., Miyazaki, T., Fujii, H., Sato, M., Kovarik, P., Decker, T., Schlessinger, J. and Taniguchi, T. ; Protein tyrosine kinase Pyk2 mediates the Jak-dependent activation of MAPK and Stat1 in the IFN- γ , but not IFN- α , signaling. *EMBO J.*, 18, 2480-2488, 1999.
 42. Nozawa, H., Oda, E., Nakao, K., Ishihara, M., Ueda, S., Yokochi, T., Ogasawara, K., Nakatsuru, Y., Shimizu, S., Ohira, Y., Hioki, K., Aizawa, S., Ishikawa, T., Katsuki, M., Muto, T., Taniguchi, T., and Tanaka, N. ; Loss of transcription factor IRF-1 affects tumor susceptibility in mice carrying the *Hras* transgene or nullizygotosity for *p53*. *Genes. Dev.* 12, 1240-1245, 1999.
 43. Oda, E., Ohki, R., Murasawa, H., Nemoto, J., Shibue, T., Yamashita, T., Tokino, T., Taniguchi, T. and Tanaka, N. ; Noxa, a BH3-only member of the Bcl-2 family, and candidate mediator of p53-induced apoptosis. *Science*, 288, 1053-1058, 2000.
 44. Takaoka, A., Mitani, Y., Suemori, H., Sato, S., Yokochi, T., Noguchi, S., Tanaka, N., and Taniguchi, T. ; Crosstalk between interferon- γ and- α/β signaling components at caveolar membrane domain. *Science*, 288, 2357-2360, 2000.
 45. Sato, M., Suemori, H., Hata, N., Asagiri, M., Ogasawara, K., Nakao, K., Nakaya, T., Katsuki, M., Noguchi, S., Tanaka, N., and Taniguchi, T. ; Distinct and essential roles of transcription factors IRF-3 and IRF-7 in response to viruses for IFN- α/β gene induction. *Immunity*, 13, 539-548, 2000.
 46. Hida, S., Ogasawara, K., Sato, K., Abe, M., Takayanagi, H., Yokochi, T., Sato, T., Hirose, S., Shirai, T., Taki, S. and Taniguchi, T. ; CD8+ T cell-mediated skin disease in mice lacking IRF-2, the transcriptional attenuator of interferon- α/β signaling. *Immunity*, 13, 643-655, 2000.
 47. Takayanagi, H., Ogasawara, K., Hida, S., Chiba, T., Murata, S., Sato, K., Takaoka, A., Yokochi, T., Oda, H., Tanaka, K., Nakamura, K. and Taniguchi, T. ; T-cell-mediated regulation of osteoclastogenesis by signalling cross-talk between RANKL and IFN- γ . *Nature*, 408, 600-605, 2000.
 48. Taniguchi, T., Ogasawara, K., Takaoka, A., and Tanaka, N. ; IRF family of transcription factors as regulators of host defense. *Ann. Rev. Immunol.* 19, 623-655, 2001.
 49. Taniguchi, T. and Takaoka, A. ; A weak signal for strong responses: Interferon - α/β Revisited. *Nature Rev. Mol. Cell Biology*, 2, 378-386, 2001.
 50. Takayanagi, H., Kim, S., Matsuo, K., Suzuki, H., Suzuki, T., Sato, K., Yokochi, T., Oda, H., Nakamura, K., Ida, N., Wagner, E. F., and Taniguchi, T. ; RANKL maintains bone homeostasis through c-Fos-dependent induction of interferon- β . *Nature*, 416, 744-749, 2002.

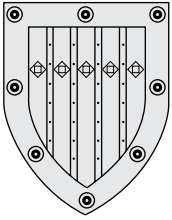

Department of Radiology

Outline and Research Objectives

Department of Radiology was established in 1932. Our department covers three major fields that are, diagnostic radiology (imaging and intervention), radiation oncology (radiotherapy) and nuclear medicine. Research activities of radiology are being carried out in cooperation with department of clinical radiology of the University of Tokyo Hospital and with department of radiology of the institute of medical science (IMS), the University of Tokyo.

Research Objectives

Diagnostic Radiology

- To develop new techniques in data acquisition of CT and MRI
- To clarify pathologic background of radiological findings.
- To develop new system for interventional procedures.

Radiation oncology

- To develop high precision radiotherapy system
- To improve radiotherapy planning.
- To clarify biological mechanisms of radiotherapy from molecular viewpoints.

Nuclear Medicine

- To develop new techniques and radiotracers in functional imaging.
- To improve image quality and quantitative accuracy in radiotracer imaging

Faculties and Students

Professor and Chair

Kuni Ohtomo MD (diagnostic radiology 1998-)

Associate Professors

Manabu Minami MD (diagnostic radiology 1999-)

Shigeki Aoki MD (diagnostic radiology 2000-)

Keiichi Nakagawa MD (radiation oncology 2002-)

Kohki Yoshikawa MD (diagnostic radiology 1997-) (IMS)

Lecturers

Toshimitsu Momose MD (nuclear medicine 1999-)

Osamu Abe MD (diagnostic radiology 2000-)

Naoto Hayashi MD (diagnostic radiology 2000-)

Masao Tago MD (radiation oncology 2001-)

Yoshitaka Masutani ED (computer science 2002-)

Yusuke Inoue MD (nuclear medicine 1999-) (IMS)

Associates9

Postdoctoral Fellow1

Graduate Students14

Residents.....6

Secretaries.....9

Past Research and Major Accomplishments

Diagnostic Radiology

1. Visualization of cerebral arteries by contrast-enhanced CT and MRI with special attention to separate between the lumen and the wall. (select publications 1-7,12)

We have revealed that dynamic contrast enhanced CT and MRI can be used to visualize vascular lumen as well as its wall.

We developed 3D-CT angiography for cerebral arteries to visualize lumen of the arteries and aneurysms. We developed a new MR angiographic technique, named "MRDSA" which can show the hemodynamics with a frame rate of subsecond. We also established the technique to see the wall of the intracranial arteries, using contrast-enhanced MR with suppression of the luminal signal by presaturation pulse. We used this technique to see the irradiated intracranial arterial wall, which sometimes show marked enhancement. We then established the way to see the dynamic contrast changes of the wall itself.

In addition to diagnosis, we performed fundamental studies of MR-guided intravascular procedures.

2. Temporal Changes of the Apparent Diffusion Coefficients (ADCs) of Water and Metabolites in Rats with Hemispheric Infarction. (select publication 15)

The purpose was to clarify the temporal changes of ADCs of cerebral metabolites during early focal ischemia. in order to assess the pathophysiology of the reduction in diffusion properties observed both in the ischemic hemisphere and in the contralateral hemisphere.

3. Fully-Automated Segmentation of Colonic Walls and Pulmonary Vessels (select publications 19-20)

We developed new segmentation methods, which are applicable in both visualization of the colon and computer-aided diagnosis in the detection of polyps in CT colonoscopy. A new method for automated segmentation of the pulmonary vascular tree in spiral CT angiography was developed based on 3D image analysis techniques and anatomic knowledge. The results are able to be applied in detection of pulmonary embolism by limiting search area of thrombi.

4. Radiologic –pathologic correlation of various diseases (select publications 8-1116.18.21-26)

In the study the images with high spatial and contrast resolution are compared with the pathologic findings and this kind of information is helpful for differential diagnosis of diseases. This approach has been successful in the field of the CNS, liver, and ovaries.

5. New virtual CT endoscopy software

To overcome some of the disadvantages of virtual endoscopy, new software called computed sectional probe (CSP) method has been developed. This software can be applied to the diagnosis of the gastrointestinal tract and tracheobronchial tree with improved detectability and more accurate tumor staging.

Radiation Oncology

1. Development of a comprehensive system for precise radiation therapy (select publications 27.30.)

A total system for radiation therapy composed of a linear accelerator unit with a microcomputer-controlled multileaf collimator and a CT scanner installed in the same treatment room was developed 17 years ago. It was a prototype system of the widely prevailing high precision radiotherapy system.

2. Megavoltage CT scanning with a medical accelerator (select publication 29 32)

Megavoltage CT scanner using 4 MV and 6 MV radiotherapy beam was developed. A detector system is composed of 120 pairs of Cadmium Tungstate scintillators. Although spatial resolution is limited, this system has been used to verify positioning errors and

beam placement in the high precision radiation therapy.

Nuclear Medicine

1. Brain activation studies by positron emission tomography (PET) (select publications 39.40)

We investigated the following issues; (I) reproducibility of regional cerebral blood flow of resting state measured by H₂O-PET;(II) effect of physiological stimulation on cerebral blood flow;(III) identification of activation areas on anatomical structures. Our data suggest that relative rCBF images and their paired subtraction are more suitable for tapping functional localization. The changes of rCBF in association cortex for more complicated tasks are, in general, smaller than those in primary cortex. PET images were taken in two different conditions: blindfolded resting state and anti-saccade. We applied these activation techniques using H₂O and PET to exploring motor function and language processing of Japanese language. We investigated functional neuroanatomy of chewing.

We investigated Japanese language processing in the brain using H₂O-PET. The results suggested that Kanji and Kana are processed differently.

2. Evaluation of the prognostic value of FDG-PET for rectal cancer (select publications 41)

We compared several variations of a semi-quantification method, the Standardized Uptake Values (SUV) and to determine the most appropriate parameter for the prognostic prediction and to propose the quantitative guideline of the FDG-PET. SUV₂ was considered to be a good prognostic indicator for long-term prognosis of rectal cancer patients.

Current Research

Diagnostic Radiology

1. Evaluation and treatment of cerebrovascular diseases with multimodality (CT, MR, US, angiography); especially with X-ray angio-open MR system.

2. MR Diffusion Tensor Analysis and Visualization (select publications 13.14)

A new display method for tractography in diffusion tensor imaging was developed. Local reliability of diffusion tracking is evaluated based on anisotropy, and paths of tracking are displayed in colors and opacity according to tracking reliability. By using several clinical data sets of volunteers and patients, the method was validated.

3. Further clinical application of 3D data acquired by Multidetector low CT (MDCT).

3-1. 3D display of secondary lobules of the lung

MDCT can generate contiguous thin section (1.25mm) CT images of the lung at every 0.6mm under single-breath holding. 3-D data of lung parenchyma is abstracted and erosion of several pixels from the lung surface can be accomplished. The structure of the secondary pulmonary lobule is clearly seen. This information will be helpful to analyze diffuse lung diseases.

3-2. 3D display of the surface of the liver

Using multi-phase dynamic study of the liver, characteristics of enhancement in each pixel can be abstracted. If the characteristics of enhancement of the liver parenchyma are set on the time-density curve, pixels showing similar enhancement pattern will be differentiated automatically on computer. This will be utilized to define the area of the liver parenchyma and eventually the data of the area will show the appearance of the liver surface three-dimensionally. The appearance will be almost the same as the liver is observed by laparoscopy or at surgery. This computer-aided automatic process will be useful the overall evaluation of changes of the liver shape and its deformity (atrophy and hypertrophy).

Radiation Oncology

1. Molecular analysis on reproductive tissue (select publications 34.35.38)

Radiation damage and recovery from ionizing radiation are being investigated from the molecular viewpoint.

2. Development of a C-arm mounted accelerator and of Dynamic Conical Conformal Radiation therapy (Dyconic CRT)

A C-arm mounted accelerator was developed. The linac head was designed to move along the C-arm with a maximum angle of 60 degrees (from a vertical position toward the gantry). Simultaneous rotation of the gantry creates a dynamic conical irradiation technique. Dyconic CRT was developed by combining the technique with continuous motion of multi-leaf collimator (MLC). Dyconic CRT enabled the precise delivery of non-coplanar beams without rotating the table.

Nuclear Medicine

1. Comparative studies of myocardial sympathetic nerve function and striatal dopaminergic function in Parkinson's disease and its related disorders.

In all patients with parkinsonism, striatum to cerebellar (ST/CBL) Ratios were significantly reduced in FDOPA-PET. Among them, only in PD and DLBD

patients, heart to mediastinum (H/M) ratios, index of myocardial sympathetic nerve function, were significantly reduced in I-123 MIBG scans. Now we are accumulating the number of patients and try to analyze the data of larger series of parkinsonian patients.

2. Correlative studies of C-11 methionine (MET) and FDG PET in the evaluation of the tumor grading of preoperative brain tumor and in the differentiation of recurrent brain tumor from radiation necrosis. For the differentiation between tumor recurrence and radiation necrosis, we are trying to decide cut-off value of both MET and FDG uptake, lesion to normal gray matter tissue count ratio (L/N).

Future Prospects

Imaging and Intervention (Diagnostic Radiology and Nuclear Medicine)

1. Neurointerventional therapy for stroke and other neurological disorders using Xray angio-MR system with monitoring diffusion/perfusion and vascular wall by MR.

2. Molecular imaging in the future

In the era of molecular medicine, molecular imaging is attracting a great deal of attention in the field of imaging science. Molecular imaging approaches the molecular basis of biological processes using imaging technology. We intend to perform researches in molecular imaging. In particular, we are planning to investigate non-invasive imaging of gene expression in living animals. We hope to contribute to developing methods for gene expression imaging and, subsequently, advancing molecular biology and molecular medicine.

3. Molecular Imaging in clinical oncology

The first point is the evaluation of angiogenesis representing activity of primary neoplasms. With advent of CT- PET system, the degree of FDG uptake will be correlated with the degree of angiogenesis. Another point is the evaluation of lymph node metastasis. New contrast materials having affinity with macrophages or tumor cells itself in the node will be available on MRI in the near future.

4. Functional imaging using CT and MRI

Functional imaging focusing on perfusion will be useful especially in the liver and kidney among the body. Another functional imaging is related to the activity of hepatocytes and Kupffer cells of the liver using tissue-specific MR contrast agents.

5. Functional imaging using radiotracers

Measurements of endogenous neurotransmitter secretion under various physiological conditions and pharmacological manipulations. We are planning to measure the amount of endogenous dopamine release from the terminals of nigrostriatal dopaminergic neurons during executing mental tasks, drug therapy and deep brain electrical stimulation in patients with Parkinson's disease, using C-11 raclopride and PET. We are also planning to develop the new radiolabeled tracers for opiate receptors, dopamine, serotonin, GABA and glutamate receptors and transporters for the evaluation of mental functions in patients with psychiatric disorders such as panic disorder, depression and schizophrenia.

Radiation Oncology

1. Image-guided real-time high dose-rate radiotherapy:

Continuous image acquisition during the therapeutic radiation visualizes errors in target localization and motion of normal structures. In rotational conformal therapy, a separate X-ray tube mounted on the linac gantry enables real-time CT imaging of the target and surrounding organs. When the system is combined with a newly investigated extremely high dose rate X-ray source (laser X-ray source), time and spatial resolution of radiotherapy will be drastically improved. It will greatly enhance radiosurgery application.

2. Tailor-made prediction of radiation sensitivity by use of DNA array tip:

Genetic factors define the radiation sensitivity of the normal tissue. Fibroblast cultures are performed sporadically but take too long time in clinical practice. DNA array analyses of single nucleotide polymorphism (SNP) may clarify how the sensitivity is determined and contribute to the decision of indication and tailor-made dose setting for radiation therapy.

Research Grants (Department of Radiology)

The Grant for Development of Advanced Medical Practice of The Ministry of Education, Science, Sports and Culture in Japan.

1. Ohtomo K. Clinical necessity of both state-of-the art CT and MR examinations in the evaluation of the same regions of the body (2000-2002 ¥30,000,000)
The Grant-in-Aid for Scientific Research (B)(2) of The Ministry of Education, Science, Sports and Culture in Japan.
2. Abe O.: Cerebral perfusion MR imaging using continuous arterial spin labeling with 2-coil system. (2001-2004 ¥13,600,000)
3. Hayashi N. Optical coherence tomography of the superficial vascular diseases: fundamental study. (2002-2005 ¥13,000,000)

Grant-in-Aid for Scientific Research (C) of The Ministry of Education, Science, Sports and Culture in Japan.

4. Nakagawa K. Megavoltage CT-assisted Stereotactic Radiosurgery for Thoracic Tumors (1999-2001, ¥3,500,000)
5. Nakagawa K. Development of computerized questionnaire system for collecting QOL information of cancer patients (2000-2001, ¥3,400,000)

Select Publications (1997-2002, except for 1.27.39) (Department of Radiology)

Diagnostic Radiology

- 1. Aoki S, Shirouzu I, Sasaki Y, Okubo T, Hayashi N, Machida T, Hoshi E, Suzuki K, Funada N, Araki T, Sasaki Y. Enhancement of the intracranial arterial wall at MR imaging: Relation ship to cerebral atherosclerosis. *Radiology* 194:477-481,1995
2. Aoki S, Osawa S, Yoshioka N, Yamashita H, Kumagai H, Araki T. Velocity-coded color MR angiography. *AJNR* 19: 691-693,1998
3. Aoki S, Aoki K, Ohsawa S, Nakajima H, Araki T. Dynamic MR images of the carotid wall. *J Magnetic Reson Imaging* 9:420-427,1999
4. Aoki S, Nakajima H, Kumagai H, Araki T. Dynamic contrast-enhanced MR angiography and MR imaging of the carotid artery: high-resolution sequences in different acquisition planes. *AJNR* 21:381-385,2000
5. Aoki S, Yoshikawa T, Hori M, Nanbu A, Kumagai H, Nishiyama Y, Nukui H, Araki T. MR digital subtraction angiography for the assessment of cranial arteriovenous malformations and fistulas. *AJR* 175:451-453,2000
6. Aoki S, Yoshikawa T, Hori M, Ishigame K, Nambu A, Kumagai H, Araki T. 2D thick-slice MR digital subtraction angiography for assessment of cerebrovascular occlusive diseases. *Eur Radiol* 10:1858-1864,2000
7. Aoki S, Hayashi N, Abe O, Shirouzu I, Ishigame K, Okubo T, Nakagawa K, Ohtomo K, Araki T. Radiation-induced arteritis: thickened wall with prominent enhancement on cranial MR images-report of five cases and comparison with 18 cases of moyamoya disease. *Radiology* 2002 223:683-688
8. Hayashi N, Yamamoto S, Okubo T, Yoshioka N, Shirouzu I, Abe O, et al. Avulsion injury of cervical nerve roots: enhanced intradural nerve roots at MR imaging. *Radiology* 1998;206(3):817-22.
9. Hayashi N, Tsutsumi Y, Barkovich AJ. Morphological features and associated anomalies of schizencephaly in the clinical population: detailed analysis of MR images. *Neuroradiology* 44(5):418-27,2002.
- 10. Hayashi N, Masumoto T, Abe O, Aoki S, Ohtomo K, Tajiri Y. Accuracy of Abnormal Paraspinal Muscle Findings on Contrast-enhanced MR Images as Indirect Signs of Unilateral Cervical Root-Avulsion Injury. *Radiology* 223(2):397-402,2002.

11. Hayashi N, Tsutsumi Y, Barkovich Polymicrogyria without porencephaly/schizencephaly. MRI analysis of the spectrum and the prevalence of macroscopic findings in the clinical population. *Neuroradiology*, In print.
 12. Yoshikawa T, Aoki S, Hori M, Nambu A, Kumagai H, Araki T. Time-resolved two-dimensional thick-slice magnetic resonance digital subtraction angiography in assessing brain tumors. *Eur Radiol* 10: 736-744, 2000.
 13. Yoshikawa T, Abe O, Tsuchiya K, Okubo T, Tobe K, Masumoto T, Hayashi N, Mori H, Yamada H, Aoki S, Ohtomo K. Diffusion-weighted magnetic resonance imaging of the dural sinus thrombosis. *Neuroradiology* 44: 481-488, 2002.
 14. Abe O, Aoki S, Hayashi N, Yamada H, Kunimatsu A, Mori H, Yoshikawa T, Okubo T, Ohtomo K. Normal aging in the central nervous system: quantitative MR diffusion-tensor analysis. *Neurobiol Aging*. 23:433-441, 2002.
 - 15. Abe O, Okubo T, Hayashi N, Saito N, Iriguchi N, Shirouzu I, Kojima Y, Masumoto T, Ohtomo K, Sasaki Y. Temporal changes of the apparent diffusion coefficients of water and metabolites in rats with hemispheric infarction: experimental study of transhemispheric diaschisis in the contralateral hemisphere at 7 tesla. *J Cereb Blood Flow Metab*. 20:726-735, 2000
 16. Mori H, Yoshioka H, Ahmadi T, Saida Y, Ohara K, Itai Y. Early radiation effects on the liver demonstrated on superparamagnetic iron oxide-enhanced T1-weighted MRI. *J Comput Assist Tomogr*. 24(4):648-51, 2000.
 17. Mori H, Abe O, Okubo T, Hayashi N, Yoshikawa T, Kunimatsu A, Yamada H, Aoki S, Ohtomo K. Diffusion property in a hamartomatous lesion of neurofibromatosis type 1. *J Comput Assist Tomogr*. 25(4):537-9, 2001.
 18. Okubo T; Yoshioka N; Hayashi N; Abe O; Masumoto T; Sasaki T; Ohtomo K
Contrast-enhanced magnetic resonance imaging of the cranial nerves in patients with acoustic schwannoma: correlation with surgical findings. *Acta Otolaryngol Suppl (Norway)*542 :13-17, 2000
 19. Masutani Y et al. Automated Segmentation and Visualization of the Pulmonary Vascular Tree in Spiral CT Angiography: An Anatomy-Oriented Approach based on Three-Dimensional Image Analysis. *J Comput Assist Tomogr* 25(4):587-597, 2001
 20. Masutani Y et al. Automated Segmentation of Colonic Walls for Computerized Detection of Polyps in CT Colonography. *J Comput Assist Tomogr* 25(4):629-638, 2001
 21. Matsuoka Y, Ohtomo K, Araki T, Kojima K, Yoshikawa W, Fuwa S. MR imaging of clear cell carcinoma of the ovary. *Eur Radiol* 11: 946-951, 2001
 22. Yoshioka N, Minami M, Inoue Y, Kawauchi N, Nakajima J, Oka T, Yoshikawa K, Ohtomo K. Pedunculated bronchogenic cyst mimicking pleural lesion. *J Comput Assist Tomogr* 24:581-583, 2000
 23. Okada Y, Ohtomo K, Kiryu S, Sasaki Y. Breath-hold T2-weighted MRI of hepatic tumors: value of echo planar imaging with diffusion-sensitizing gradient. *J Comput Assist Tomogr*. 22:364-371, 1998.
 24. Kobayashi Y, Minami M, Ohtomo K, Matsuoka Y. MR imaging and CT appearance of aggressive angiomyxoma. *AJR* 169:1752-1753, 1997.
 25. Minami M, Itai Y, Charnsangavej C, Ohtomo K, Kawauchi N, Sasaki Y. "Periportal collar" sign of the liver: pathophysiologic approach. In: Selected scientific exhibits in gastrointestinal radiology: RSNA 1996 Radiographics 17(suppl 2): 1616-1620(abstr) 1997
 26. Ohtomo K, Matsuoka Y, Abe O, Okada M, Amo K, Minami M, Kawauchi N, Sasaki Y. High-resolution MR imaging evaluation of hepatocellular carcinoma. *Abdom Imaging* 22:182-186, 1997.
- Radiation Oncology**
- 27. Nakagawa K, Aoki Y, Akanuma A, Onogi Y, Terahara A, Sakata K, Muta N and Sasaki Y. Real-time beam monitoring in dynamic conformation therapy. *International Journal of Radiation Oncology, Biology, Physics* 30, 1233-1238, 1994
 28. Nakagawa K, Aoki Y, Kusama T, Ban N and Nakagawa S. Radiotherapy during pregnancy and its effects on fetuses and neonates. *Clinical Therapeutics* 19, 770-777, 1997
 29. Nakagawa K, Aoki Y and Sasaki Y. Improvement of image quality in megavoltage computed tomography with second generation scanning mode. *Radiation Oncology Investigation* 5, 257-263, 1997
 - 30. Nakagawa K, Aoki Y, Fujimaki T, Tago M, Terahara A, Karasawa K, Sakata K, Sasaki Y, Matsutani M and Akanuma A. High dose conformal radiotherapy influenced pattern of failure, but did not improve survival of glioblastoma multiforme. *International Journal of Radiation Oncology, Biology, Physics* 40, 1141-1149, 1998
 31. Nakagawa K, Aoki Y, Ohtomo K, Albright N and Goer D. Dosimetry of leakage doses from a mobile accelerator for IORT and legal issues for its clinical use in Japan. *International Journal of Clinical Oncology* 4, 215-219, 1999
 - 32. Nakagawa K, Aoki Y, Tago M, Terahara A and Ohtomo K. Megavoltage CT-assisted stereotactic radiosurgery for thoracic tumors: original research in the treatment of thoracic neoplasms. *International Journal of Radiation Oncology, Biology, Physics* 48, 449-457, 2000
 33. Tago M, Terahara A, Nakagawa K, Aoki Y, Ohtomo K, Shin M and Kurita H. Immediate neurological deterioration after gamma knife radiosurgery for acoustic neurinoma. *J Neurosurg* 93, 78-81, 2000
 34. Kozuka T, Aoki Y, Nakagawa K, Ohtomon K, Yoshikawa H, Matsumoto K, Yoshiike K and Kanda T. Enhancer-promoter activity of human papillomavirus type 16 long control regions isolated from cell lines SiHa and CaSKI and cervical cancer biop-

- sies. Japanese Journal of Cancer Research 91, 271-279, 2000
35. Takeuchi T, Kozuka T, Nakagawa K, Aoki Y, Ohtomo K, Yoshiike K and Kanda T. Adeno-associated virus type 2 nonstructural protein rep78 suppresses translation in vitro. *Virology* 266, 196-202, 2000
 36. Nakagawa K, Kozuka T, Akahane M, Suzuki G, Akashi M, Hosoi Y, Aoki Y and Ohtomo, K. Radiological findings of accidental radiation injury of the fingers. *Health Physics* 80, 67-70, 2001
 37. Nakagawa K, Tago M, Terahara A, Aoki Y, Sasaki T, Kurita H, Shin M, Kawamoto S, Kirino T and Ohtomo K. A single institutional outcome analysis of gamma knife radiosurgery for single or multiple brain metastases. *Clinical Neurology and Neurosurgery* 102, 227-232, 2001
 38. Igaki H, Nakagawa K, Aoki Y, Ohtomo K, Kukimoto I and Kanda T. Characterization of the Bi-directional transcriptional control region between the human UFD1L and CDC45L genes. *Biochemical and biophysical Research Communications* 283, 569-576, 2001
 - ene diphosphonate after nephron sparing surgery. *J Nucl Med* 40: 418-421, 1999
 47. Inoue Y, Ohtake T, Homma Y, Yoshikawa K, Nishikawa J, Sasaki Y Evaluation of glomerular filtration rate by a camera-based method in children and adults. *J Nucl Med* 39: 1784-1788, 1998
 48. Inoue Y, Ohtake T, Yoshikawa K, Nishikawa J, Sasaki Y Estimation of deadtime in imaging human subjects. *Eur J Nucl Med* 25: 1232-1237, 1998
 49. Inoue Y, Momose T, Ohtake T, Asai S, Yoshikawa K, Nishikawa J, Sasaki Y Effect of deadtime loss on quantitative measurement of cerebral blood flow with technetium-99m hexamethylpropyleneamine oxime. *Eur J Nucl Med* 24: 1418-1421, 1997
 50. Inoue Y, Momose T, Ohtake T, Nishikawa J, Sasaki Y, Waritani T, Inoue M Metabolism of technetium-99m-L,L-ethyl cysteinyl dimer in rat and cynomolgus monkey tissue. *J Nucl Med* 38: 1731-1737, 1997

Nuclear Medicine

- 39. Momose T, Sasaki Y, Sakurai Y, Iwata M. Functional studies with O-15 H₂O PET. *Biomed Research* 13(Suppl 1); 77-82, 1992.
- 40. Momose T, Nishikawa J, Watanabe T, Sasaki Y, Senda M, Kubota K, Sato Y, Funakoshi M and Minakuti S. Effect of mastication on regional cerebral blood flow in humans examined by positron emission tomography with O-15 labelled water and magnetic resonance imaging. *Archs oral Biol.* 42: 57-61, 1997
41. Oku S, Nakagawa K, Momose T, Kumakura Y, Abe A, Watanabe T and Ohtomo K FDG-PET after radiotherapy is the best prognostic indicator of rectal cancer. *Annals Nucl Med* :16(6), 2002, in press.
- 42. Inoue Y, Abe O, Kawakami T, Ozaki T, Inoue M, Yokoyama I, Yoshikawa K, Ohtomo K Metabolism of ^{99m}Tc-ECD in infarcted brain tissue of rats. *J Nucl Med* 42: 802-807, 2001
- 43. Inoue Y, Yoshikawa K, Yoshioka N, Watanabe T, Saegusa S, Kaneko Y, Yokoyama I, Ohtomo K Evaluation of renal function with ^{99m}Tc-MAG3 using semiautomated regions of interest. *J Nucl Med* 41: 1947-54, 2000
44. Inoue Y, Yoshikawa K, Suzuki T, Katayama N, Yokoyama I, Kohsaka T, Tsukune Y, Ohtomo K Attenuation correction in evaluating renal function by a camera-based method in children and adults. *J Nucl Med* 41: 823-829, 2000
45. Inoue Y, Ohtake T, Yokoyama I, Yoshikawa K, Asai S, Ohtomo K Evaluation of renal function from technetium-99m-MAG3 renography without blood sampling. *J Nucl Med* 40: 793-798, 1999
46. Inoue Y, Ohtake T, Kameyama S, Yamazaki S, Kawabe K, Yoshikawa K, Nishikawa J, Sasaki Y Increased renal retention of technetium-99m methyl-

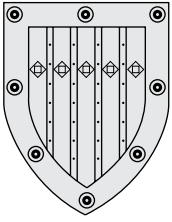

Department of Radiation Oncology (Experimental Radiology)

Outline and Research Objectives

The department was founded in 1966 to carry out education and research on clarification of radiation effect on cells and tissues through biological and biochemical understanding.

Our recent research program(s) have focused on the basic studies for radiation oncology and radiotherapy through understanding molecular biological basis of radiation responses in cells and tissues.

The standardized radiotherapy has been daily fractionated irradiation of 2 Gy for about 6 weeks by which tumor cells lose clonogenic potential while normal tissues involved are saved and recover. To clarify the mechanisms involved in the process and to devise better methods for radiotherapy have been the subject of vigorous study for decades. DNA has been considered as the target for radiation action on the cells causing mitotic or reproductive cell death while a fertilized egg divides into various tissue cells and organs with the same DNA but with different radiosensitivity. Tumors and normal tissues differ in radiosensitivity depending on intrinsic cellular radiosensitivity, cell kinetics, schedule of fractionation, type or quality of radiation used, radiation dose, assay systems used and physiological conditions such as pO₂, pH, nutrient etc. However, the molecular mechanisms for the differences have been little clarified.

Toward this goal the specific projects aimed at the following problems have been planned and in progress.

Specific Aims:

- 1) To clarify biological mechanisms underlying radiation responses of normal tissues and tumors.
- 2) To clarify mechanism(s) and signal-transduction pathway(s) of cell death, tissue damage and regeneration after irradiation and/or heat treatment, especially of apoptosis (programmed cell death)
- 3) To establish predictive assay method(s) such as DNA and protein (antibody) arrays to help select treatment methods, i.e., type of radiation source(s) and irradiating protocol(s) suitable to individual patient and tumor.
- 4) To develop new methods for sensitization of tumor cells and for prevention of normal tissue damages.

Faculties and Students

Professor and Chair Norio Suzuki, M.D., Ph.D. (1986~)
 Associate Professor Yoshio Hosoi, M.D., Ph.D.
 Associates2
 Graduate students.....2
 Research students.....2

Past Research and Major Accomplishments

1. Quantitative assay system for mutation of cultured mammalian cells
2. Quantification of radiation induced mutation frequencies of mammalian cells in vitro or in vivo
3. Method to determine DNA synthesis point during S-phase using mutation marker

4. Variability and instability of tumor cells in DNA and various malignant properties
5. Clarification of metastatic processes and their relevance to radiation responses in mouse tumor system
6. Cell cycle dependence of metastatic lung colonization in mouse tumor system
7. New assay methods of metastasizing tumor cells released into the blood of mice
8. Characterization of normal tissue stem cells especially testicular spermatogenic stem cells of mouse
9. Existence of hypoxic cells among mouse spermatogenic stem cells
10. Random lifetime and exponential decrease of mouse spermatogenic stem cells

11. Activation of immune response by low dose irradiation
12. Inhibition of metastasis by low dose total body irradiation
13. Sensitization of cells to ionizing radiation by Chlorin e6Na

Current Research

Regarding radiation induced cell death, mitotic or reproductive cell death has been traditionally considered significant and meaningful one underlying tumor cure and tissue damages. DNA double-strand breaks (DSBs) are considered most harmful among various DNA damages induced by ionizing radiation and the primary cause for cell death. Thus, cellular repair capacity of DSBs is a critical factor of radiosensitivity. DSBs are mainly repaired by homologous recombination and non-homologous end joining (NHEJ). DNA-dependent protein kinase (DNA-PK) is required for NHEJ. We have previously reported that inactivation of DNA-PK by wortmannin or other drugs sensitized cells to ionizing radiation.

On the other hand, tumor cells and normal tissue cells have also been known to express apoptotic (interphase) cell death after irradiation and various tumor cells are defective in apoptotic pathway and process. The role and significance of apoptotic cell death in tumor cure or tissue damages depend on histological type or individual tumors and tissues.

We have been focusing currently on clarification of signal transduction and process of cell death, especially apoptotic cell death after irradiation or heat treatment. T cell lymphoma, MOLT-4 cells (p53 wild), and monoblastic U937 cells (p53 null) were mainly used. The other focus has been clarification of the function and the role of DNA-PK in signal transduction of DSB repair and cell death.

1. Signal transduction mechanisms involved in radiation- or heat-induced cell death

As for involvement of receptor-mediated signaling including Fas and TNFR, MOLT-4 cells stimulated by these ligand did not undergo apoptosis, and irradiated cells did not exhibit any mature form of caspase-8, although Fas expression of MOLT-4 was upregulated by irradiation. Dose dependency of p53 expression and dominant negative effect of p53 on radiation-induced cell death of MOLT-4 cells have been reported. Expression of p53-related genes and the mechanism of the mitochondrial pathway are under-investigation.

1-1) Ceramide-JNK pathway

We have recently demonstrated the important

roles of ceramide-JNK pathway as well as p53 pathway in radiation-induced cell death of MOLT-4 cells; 1) acid sphingomyelinase inhibitor suppressed X-ray-induced apoptosis of MOLT-4 cells. 2) Rh-1a clone, a clone selected for radio-resistance from MOLT-4 cells, was found resistant also to C2-ceramide-induced apoptosis, with less activation of JNK. 3) the activation of JNK after X-irradiation or the treatment with a JNK activator anisomycin caused the decrease of c-Myc expression, 4) the reduction and/or inactivation of c-Myc by c-Myc inhibitor led to apoptotic cell death.

We also demonstrated that the important roles of ceramide-JNK pathway in heat-induced cell death in p53 null U937 cells by the transfection with the dominant negative c DNA of JNK into the cultured cells or the treatment with acid sphingomyelinase inhibitor. We are studying further the mechanisms of heat-induced apoptosis and the role of ceramide-JNK signal transduction pathway in the thermo-tolerance development.

1-2) p41-induction in radiation-induced apoptosis

p41, an acidic 41-kDa protein (pI=4.0) was newly found in our laboratory as a radiation-induced protein during apoptotic cell death of irradiated MOLT-4. The protein was detected in two-dimensional polyacrylamide gel electrophoresis (2-D PAGE) and silver staining. The protein appeared radiation dose and time dependent. Amino acid sequence analysis of partial peptides showed homology between p41 and a putative oncogene, *set* (also known as template activating factor I, TAF-I). A polyclonal antibody was raised against a synthetic partial peptide of p41. Immunoblotting analysis of irradiated MOLT-4 cells showed two spots, p41 and an additional 42-kDa protein, p42 (pI=4.1). p42 was detectable also in untreated cells. N-terminal amino acid sequencing of partially purified p41 and p42, and polyclonal antibodies newly raised against different partial peptide sequences revealed that p41 was a N-terminal truncation form of p42, and p42 was identified as SETb (TAF-Ib), one of two SET isoforms. The cleavage site was at carboxyl end of SNHD 18 of p42. A caspase-specific inhibitor or overexpressing of Bcl-2 suppressed radiation-induced p42 cleavage as well as apoptotic cell death of MOLT-4. *In vitro* cleavage experiments with recombinant p42 and either irradiated cell extracts or recombinant caspases, concluded that the cleavage of p42 into p41 was catalyzed by caspase(s) mainly by caspase-7.

One of newly raised antibodies specific to p41 or specific to cleavage site of p42, was found useful enabling simple detection of p41 by 1-D PAGE instead of laborious 2-D PAGE. p41 would serve as a marker of apoptotic cell death. The study on the role and sig-

nificance of p41-induction in radiation-induced apoptosis will be continued.

2. The function and the role of DNA-dependent protein kinase (DNA-PK)

2-1) Target molecules and phosphorylation.

Although more than 30 proteins have been reported as DNA-PK substrates *in vitro*, it has been unknown whether these were true targets *in vivo*. We recently demonstrated XRCC4, a DNA ligase IV-associated protein, as the first example of *in vivo* substrate in response to radiation. We also identified a new phosphorylation site in p53. Through the generation of phosphorylation-specific antibodies and the analysis of phosphorylation-site-disruptants, we are now attempting to clarify the role of the phosphorylation of XRCC4 and p53 in the repair and/or the signal transduction of DNA double-strand breaks.

2-2) Hyperthermic lability and hyperthermic radiosensitization

Radiosensitizing effect of hyperthermia has been widely accepted and applied in cancer therapy. Although many studies proposed various mechanisms for the sensitization, the problem has not been solved and still controversial. We examined hyperthermic stability of purified DNA-PK and its subunits. We found and proposed heat lability of Ku subunit as a possible mechanism for hyperthermic radiosensitization. We also found that the heat stability of DNA-PK was much higher in human cells than in rodent cells, which may reflect the fact that many human cancer cells are more refractory than mouse tumor cells to hyperthermia. We are now studying to modify stability of DNA-PK for improved hyperthermia-radiation therapy.

2-3) Wortmannin affects apoptosis other than repair

Higher concentration of wortmannin such as 5 μ M or above, which were required for inhibition of DNA-PK and ATM, caused enhanced radiation or heat induced apoptotic cell death in MOLT-4 and V79 cells. The apoptotic process overrode ongoing repair process.

2-4) Prediction of radiation sensitivity.

We found that DNA-PK activity was high in human esophageal and colon cancer tissues compared with control normal tissues. The protein and mRNA expressions of Ku70, Ku80, and DNA-PKcs were also high in the esophageal and colon cancer tissues. The protein and mRNA expressions of Ku70/80 correlated with DNA-PK activity. However, other studies including our own showed various results and the studies are inconclusive.

2-5) Phosphorothioate oligonucleotide and its analogues as inhibitors of DNA-dependent protein kinase

We are currently studying the functions, the properties and the regulation mechanisms such as post-translational modifications, of key enzymes in DSB repair. We reported that phosphorothioate oligonucleotide and its analogue inhibited DNA-PK activity and sensitized cells to ionizing radiation. The results also showed 1) Correlation between DNA-PK activity and radiation sensitivity 2) Roles of DNA-PK and ATM in cell-cycle-dependent radiation sensitivity 3) Activation of epidermal growth factor receptor by ionizing radiation

Future Prospects

We hope that these studies will eventually lead us to understanding mechanisms of difference in radiation responses among tissues and tumors, to the discovery and development of radiosensitizers/protectors, and also to the construction of gene/protein array for predictive assay.

Research Grants

1. Scientific Research in Priority Areas (2) (1998-2000, 2001-2002)
P. I. Norio Suzuki
"Molecular mechanisms of Radiation-responses and radiosensitivity"
2. Exploratory Research (2002-2003)
P. I. Norio Suzuki
"DNA- and Protein-array for radiosensitivity"
3. Scientific Research in Priority Areas (2) (2001)
P. I. Yoshio Hosoi
"Prediction of radiation sensitivity and radio-sensitization using DNA-dependent protein kinase"
4. Scientific Research in Priority Areas (2) (2001-2002)
P. I. Yoshihisa Matsumoto
"The function of DNA-dependent protein kinase in radiation response and its possible application in cancer radiation therapy I"
5. Grant-in-Aid for Young Scientists (B) (2001-2002)
P. I. Atsushi Enomoto
"Analysis of the signal-transduction pathways and the gene expressions using DNA micro-array system on radiation effects"

Select Publications

1. Suzuki, N., Kawabe, S., Matsushima, T., and Sugimura, T. Molecular species of aldolase in the liver of tumor-bearing rats. *Gann* 60, 433-437, 1969.

2. Sugimura, T., Sato, S., Kawabe, S., Suzuki, N., Chen, T. C., and Takakura, K. Aldolase C in brain tumor. *Nature* 222, 1070, 1969.
3. Suzuki, N., and Okada, S. Location of Ala 32 gene replication in the cell cycle of cultured mammalian cells, L5178Y. *Mutat. Res.* 30, 111-116, 1975.
4. Suzuki, N., and Okada, S. Isolation of nutrient deficient mutants and quantitative mutation assay by reversion of alanine-requiring L5178Y cells. *Mutat. Res.* 34, 489-506, 1976.
5. Suzuki, N., and Okada, S. γ -Ray mutagenesis of cultured mammalian cells in vitro and in vivo. *Mutat. Res.* 43, 81-90, 1977.
6. Suzuki, N., Withers, H. R., and Hunter, N. Radiosensitization of mouse spermatogenic stem cells by Ro-07-0582. *Radiat. Res.* 69, 598-601, 1977.
7. Suzuki, N., Frapart, M., Gardina, D. J., Meistrich, M. L., and Withers, H. R. Cell cycle dependency of metastatic lung colony formation. *Cancer Res.* 37, 3690-3693, 1977.
8. Nakamura, N., Suzuki, N., Harakawa, H., and Okada, S. Mutagenicity of furylfuramide, a food preservative tested by using alanine-requiring mouse L5178Y cells in vitro and in vivo. *Mutat. Res.* 46, 355-364, 1977.
9. Okamura, S., Suzuki, N., Ishikawa, H., and Yamada, E. Quantitative changes in organelles during the cell cycle of mouse leukemia cells as studied by electron microscopy. *Cell Struct. and Func.* 2, 229-240, 1977.
10. Mian, T. A., Suzuki, N., Glenn, H. J., Haynie, T. P., and Meistrich, M. L. Radiation damage to mouse testis cells from ^{99m}Tc pertechnetate. *J. Nucl. Med.* 18, 1116-1122, 1977.
11. Suzuki, N., Withers, H. R., and Lee, L. Y. Variability of DNA content of murine fibrosarcoma cells. *Nature* 269, 531-532, 1977.
12. Suzuki, N., Withers, H. R., and Williams, M. Radiation response in vitro in vivo of various clones from a fibrosarcoma. *Radiat. Res.* 74, 503-504, 1978.
13. Suzuki, N., and Withers, H. R. Isolation from a murine fibrosarcoma of cell lines with enhanced plating efficiency in vitro. *J. Natl. Cancer Inst.* 60, 179-183, 1978.
14. Suzuki, N., Withers, H. R., and Williams, M. Heterogeneity and variability of artificial lung colony forming ability among clones from a mouse of fibrosarcoma. *Cancer Res.* 38, 3349-3351, 1978.
15. Meistrich, M. L., Hunter, N. R., Suzuki, N., Trostle, P. K., and Withers, H. R. Gradual regeneration of mouse testicular stem cells after ionizing radiation. *Radiat. Res.* 74, 371-384, 1978.
16. Suzuki, N., and Withers, H. R. Exponential decrease during aging and random lifetime of mouse spermatogonial stem cells. *Science* 202, 1214-1215, 1978.
17. Suzuki, N., and Withers, H. R. Lung colony formation as a selective cloning process for lung colony forming ability. *Br. J. Cancer* 39, 196-199, 1979.
18. Suzuki, N., Williams, M., Hunter, N. M., and Withers, H. R. Malignant properties and DNA content of daughter clones from a mouse fibrosarcoma differentiation among malignant properties. *Br. J. Cancer* 42, 765-771, 1980.
19. Suzuki, N. Spontaneous versus artificial lung metastasis discrepant effect of whole-body irradiation in NFSA2ALM and NFSA1SLM tumor systems. *J. Natl. Cancer Institute* 71, 835-839, 1983.
20. Suzuki, N. New method to quantitate clonogenic tumor cells in the blood circulation of mice. *Cancer Res.* 43, 5451-5455, 1983.
21. Suzuki, N. Variant selection and blood-borne "Clonogenic" tumor cells in metastasis of FSA cell clones. *Br. J. Cancer* 48, 827-833, 1983.
22. Suzuki, N. Radiation response of "Clonogenic" tumor-cell release from NFSA2ALM1 tumors. *Radiat. Res.* 98, 649-655, 1984.
23. Suzuki, N. Centrifugal elutriation and characterization of tumor cells from the venous blood of tumor-bearing-mice possible relevance to metastasis. *Cancer Res.* 44, 3505-3511, 1984.
24. Sakai, K., Suzuki, N., Nakamura, N., and Okada, S. Induction and subsequent repair of DNA damage by fast neutrons in cultured mammalian cells. *Radiat. Res.* 110, 311-320, 1987.
25. Suzuki, N., and Mizukoshi, T. Effect of low dosed of whole body irradiation on spontaneous lung metastasis of NFSA-2-ALM1 mouse tumors. *Radiat. Med.* 5, 801-803, 1987.
26. Kobayashi, Y., Okabe, T., Urabe, A., Suzuki, N., and Takaku, F. Human granulocyte colony stimulating factor produced by *Escherichia coli* shortens the period of granulocytopenia induced by irradiation in mice. *Jpn. J. Cancer Res.* 78, 763-766, 1987.
27. Sakata, K., Okada, S., Majima, H., and Suzuki, N. Linear quadratic model of radiocurability on multicellular spheroids of human lung adenocarcinoma LCT1 and mouse fibrosarcoma FSA. *Int. J. Radiat. Biol.* 61, 269-274, 1992.
28. Majima, H., Kashiwado, K., Egawa, S., and Suzuki, N. Interaction between the kinetics of thermotolerance and effect of cis-diamminedichloroplatinum(II) or bleomycin given at 37 °C or 43 °C. *Int. J. Hyperthermia* 8, 431-442, 1992.
29. Kobayashi, S., Kasuya, M., Ishii, Y., Takehana, M., Sakai, K., Suzuki, N., and Itoi, M.
30. Effects of 2-mercaptopyrionylglycine on the development of X-ray-induced cataract in rats. *Current Eye Reseach* 11, 1099-1103, 1992.
31. Takakura, K., Ishikawa, M., Minegishi, A., Sakai, K., Suzuki, N., and Okada, S. Inverse dose-rate effect of DNA breaks and inactivation of transforming activity induced by tritiated water and ^{60}Co gamma-rays. *Radiat. Environ. Biophys.* 31, 299-310, 1992.
32. Hosoi, Y., and Kapp, Y. Expression of a candidate ataxia-telangiectasia group D gene in cultured fibroblast cell lines and human tissues. *Int. J. Radiat. Biol.* 66, s71-s76, 1994.
33. Morimatsu, A., Suzuki, N., Hirano, K., Sakai, K., and Matsumoto, Y. Identification and characterization of

- X-ray-induced proteins in human T cell leukemia. *J. Radiat. Res.* 37, 1-11, 1996.
34. Matsumoto, Y., Suzuki, N., Sakai, K., Morimatsu, A., Hirano, K., and Murofushi, H. A possible mechanism for hyperthermic radiosensitization mediated through hyperthermic lability of Ku subunits in DNA-dependent protein kinase. *Biochem. Biophys. Res. Commun.* 234, 568-572, 1997.
 35. Hosoi, Y., Miyachi, H., Matsumoto, Y., Ikehata, H., Komura, J., Ishii, K., Zhao, H. J., Yoshida, M., Takai, Y., Yamada, S., Suzuki, N., and Ono, T. A phosphatidylinositol 3-kinase inhibitor, wortmannin, induces radioresistant DNA synthesis, and sensitizes cells to bleomycin and ionizing radiation. *Int. J. Cancer* 78, 642-647, 1998.
 36. Matsumoto, Y., Umeda, N., Suzuki, N., Sakai, K., and Hirano, K. A gel-electrophoretic analysis for improved sensitivity and specificity of DNA-dependent protein kinase activity. *J. Radiat. Res.* 40, 183-186, 1999.
 37. Morita, A., Suzuki, N., Matsumoto, Y., Hirano, K., Enomoto, A., Zhu, J., and Sakai, K. p41 as a possible marker for cell death is generated by caspase cleavage of p42/SET β in irradiated MOLT-4 cells. *Biochem. and Biophys. Res. Commun.* 278, 627-632, 2000.
 38. Enomoto, A., Suzuki, N., Hirano, K., Matsumoto, Y., Morita, A., Sakai, K., and Koyama, H. Involvement of SAPK/JNK pathway in X-ray-induced rapid cell death of human T-cell leukemia cell line MOLT-4. *Cancer Lett.* 155, 137-144, 2000.
 39. Matsumoto, Y., Suzuki, N., Namba, N., Umeda, N., Ma, X.-J., Morita, A., Tomita, M., Enomoto, A., Serizawa, S., Hirano, K., Sakai, K., Yasuda, and H., Hosoi, Y. Cleavage and phosphorylation of XRCC4 protein induced by X-irradiation. *FEBS Lett.* 478, 67-71, 2000.
 40. Kang, Y., Hirano, K., Suzuki, N., Enomoto, A., Morita, A., Irimura, T., and Sakai, K. Increased expression after X-irradiation of MUC1 in cultured human colon carcinoma HT-29 cells. *Jpn. J. Cancer Res.* 91, 324-330, 2000.
 41. Tomita, M., Suzuki, N., Matsumoto, Y., Hirano, K., Umeda, N., and Sakai, K. Sensitization by wortmannin of heat-or X-ray induced cell death in cultured Chinese hamster V79 cells. *J. Radiat. Res.* 41, 93-102, 2000.
 42. Zhao, H.-J., Hosoi, Y., Miyachi, H., Ishii, K., Yoshida, M., Nemoto, K., Takai, Y., Yamada, S., Suzuki, N., and Ono, T. DNA-dependent protein kinase activity correlates with Ku70 expression and radiation sensitivity in esophageal cancer cell lines. *Clin. Cancer Res.* 6, 1073-1078, 2000.
 43. Ono, T., Ikehata, H., Nakamura, S., Saito, Y., Hosoi, Y., Takai, Y., Yamada, S., Onodera, J., and Yamamoto, K. Age-associated increase of spontaneous mutant frequency and molecular nature of mutation in newborn and old lacZ-transgenic mouse. *Mutat. Res.* 447 165-177, 2000.
 44. Nakamura, S., Ikehata, H., Komura, J., Hosoi, Y., Inoue, H., Gondo, Y., Yamamoto, K., Ichimasa, Y., and Ono, T. Radiation-induced mutation in spleen and brain of plasmid-based lacZ transgenic mouse. *Int. J. Radiat. Biol.* 76, 431-440, 2000.
 45. Sakata, K., Matsumoto, Y., Tauchi, H., Satoh, M., Oouchi, A., Nagakura, H., Koito, K., Hosoi, Y., Suzuki, N., Komatsu, K., and Hareyama, M. Expression of genes involved in repair of DNA double-strand breaks in normal and tumor tissues. *Int. J. Radiat. Oncol. Biol. Phys.* 49, 161-167, 2001.
 46. Sakata, K., Matsumoto, Y., Satoh, M., Oouchi, A., Nagakura, H., Koito, K., Hosoi, Y., Hareyama, M., and Suzuki, N. Clinical studies of immunohistochemical staining of DNA-dependent protein kinase in oropharyngeal and hypopharyngeal carcinomas. *Radiat. Med.* 19, 93-97, 2001.
 47. Enomoto, A., Suzuki, N., Liu, C., Kang, Y., Zhu, J., Serizawa, S., Matsumoto, Y., Morita, A., Ito, M., and Hosoi, Y. Involvement of c-Jun NH2-terminal kinase-1 in heat-induced apoptotic cell death of human monoblastic leukemia U937 cells. *Int. J. Radiat. Biol.* 77, 867-874, 2001.
 48. Mori, N., Matsumoto, Y., Okumoto, M., Suzuki, N., and Yamate, J. Variations in *Prkdc* encoding the catalytic subunit of DNA-dependent protein kinase (DNA-PKcs) and susceptibility to radiation-induced apoptosis and lymphomagenesis. *Oncogene* 20, 3609-3619, 2001.
 49. Ishii, T., Futami, S., Nishida, M., Suzuki, T., Sakamoto, T., Suzuki, N., and Maekawa, K. Brief note and evaluation of acute-radiation syndrome and treatment of a tokai-mura criticality accident patient. *J. Radiat. Res.* 42, S167-S182, 2001.
 50. Nakagawa, K., Kozuka, T., Akahane, M., Suzuki, G., Akashi, M., Hosoi, Y., Aoki, Y., Ohtomo, K. Radiological findings of accidental radiation injury of the fingers A case report. *Healphy Phys.* 80, 67-79, 2001.
 51. Hosoi, Y., Matsumoto, Y., Tomita, M., Enomoto, A., Morita, A., Sakai, K., Nakagawa, K., Umeda, N., Zhao, H.-J., Ono, T., and Suzuki, N. Phosphorothioate oligonucleotides, suramin and heparin inhibit DNA-dependent protein kinase activity. *Br. J. Cancer* 86, 1143-1149, 2002.
 52. Yoshida, M., Hosoi, Y., Miyachi, H., Ishii, N., Matsumoto, Y., Enomoto, A., Nakagawa, K., Yamada, S., Suzuki, N., and Ono, T. Roles of DNA-dependent protein kinase and ATM in cell-cycle dependent radiation sensitivity in human cells. *Int. J. Radiat. Biol.* 78, 503-512, 2002.
 53. Komuro, Y., Watanabe, T., Hosoi, Y., Matsumoto, Y., Nakagawa, K., Kitayama, J., Suzuki, N., and Nagawa, H. The expression pattern of Ku correlates with tumor radiosensitivity and disease free survival in patients with rectal carcinoma. *Cancer* 95, 1199-1205, 2002.

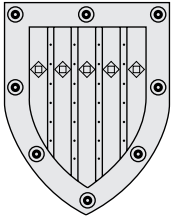

Department of System Physiology

Outline and Research Objectives

This department was originally a part of the Research Institute of Medical Electronics operated by the School of Medicine, but in 1997, when the University of Tokyo restructured its system of education and research, the Institute became the Division of Biomedical Engineering in the Graduate School of Medicine. The Division of Biomedical Engineering consists of three departments: Bioimaging and Biomagnetics, Biosystem Construction and Control, and our own System Physiology.

This laboratory has been pursuing research on the biomechanics of phenomena in the human body, especially focusing on cellular sensing and response mechanisms to mechanical stimuli. The main theme of our work has been the relationships between the mechanical force generated by blood flow, shear stress and the cells exposed to it, vascular endothelial cells. Research on this theme will be of benefit not only in understanding blood-flow-mediated regulation of vascular functions but in elucidating issues that are of importance clinically, such as angiogenesis, vascular remodeling, and atherogenesis, all of which occur in a blood flow-dependent manner.

Original biomedical engineering methods have been applied in which cultured endothelial cells are exposed to controlled levels of fluid shear stress in a dynamically designed flow apparatus (Fig. 1) and their responses are analyzed at the cellular and molecular levels.

Faculty and Students

Professor and Chair Joji Ando, M.D., Ph.D. (since 2000)
Lecturers Masahiro Shibata, Ph.D.
Associates1
Graduate Students3

Past Research and Major Accomplishments

Our studies have involved experiments on the following:

1. Endothelial cell responses to shear stress
2. Shear stress-mediated regulation of endothelial gene expression
3. Shear stress signal transduction in endothelial cells
4. In vivo analysis of blood flow effects

And the results are described below.

Endothelial cell responses to shear stress

Our studies have demonstrated that endothelial cells exhibit functional responses to shear stress. When a cultured endothelial cell monolayer was partially denuded, surrounding cells migrated and proliferated in the denuded area, and covered it. Shear stress enhanced the regenerative functions of endothelial cells (Microvasc Res 1987, Biorheology, 1990), and it increased the production of nitric oxide, a potent vasodilator, in endothelial cells in a dose-dependent manner (BBRC 1994). It also increased the expression of thrombomodulin, an antithrombotic molecule, in endothelial cells (BBRC 1994). By contrast, shear stress decreased the expression of vascular cell adhesion molecule-1 (VCAM-1), which led to inhibition of leukocyte adhesion to endothelial cells (BBRC 1993, Am J Physiol 1994). A collaborative study

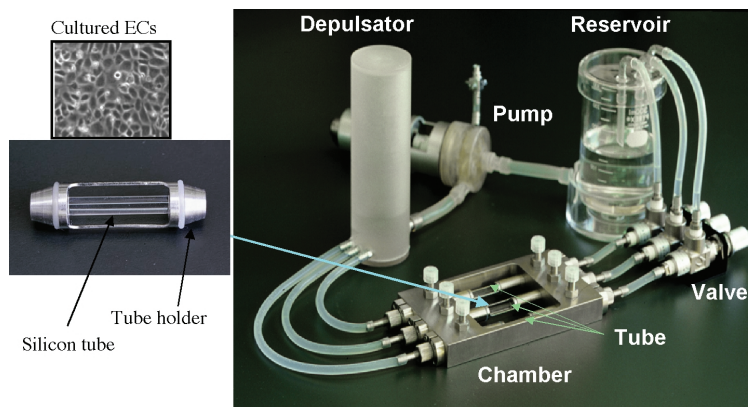

Fig. 1. A silicon-tube-type flow-loading apparatus.

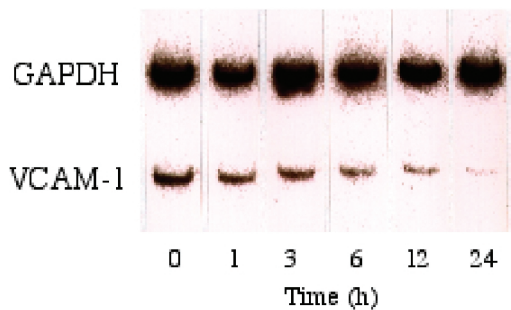

Fig. 2. Downregulation of VCAM-1 mRNA levels by shear stress.

showed that shear stress increases the levels of adrenomedullin and C-type natriuretic peptide mRNA, which have vasodilating effects (Hypertension 1997), and that it augments the expression of low density lipoprotein receptor (LOX-1) at both the protein and mRNA level (Circ Res 1998).

Shear-stress-mediated regulation of endothelial gene expression

We have demonstrated that shear stress regulates endothelial gene expression transcriptionally and/or posttranscriptionally. It downregulates VCAM-1 gene transcription via the double AP-1 binding element (TGACTCA) in the promoter, which functions as a shear stress-responsive element (Am J Physiol 1997).

Fig.2 shows shear stress-induced changes in VCAM-1 mRNA levels determined by the reverse transcriptase PCR method. Shear stress has also been shown to increase the level of granulocyte/macrophage-colony stimulating factor (GM-CSF) via mRNA stabilization (Circ Res 1988). Differential display analysis showed that approximately 600 known and unknown transcripts are up- or down-regulated in human umbilical vein endothelial cells exposed to a shear stress of 15 dynes/cm² for 6 h (BBRC 1996), and a cDNA encoding an unknown G-protein coupled receptor was cloned from these shear stress-responsive genes (BBRC 1997).

Shear-stress signal transduction in endothelial cells

We were the first to show that Ca²⁺ signaling plays an important role in the mechanism by which endothelial cells recognize the shear stress signal and transmit it into the cell interior (In Vitro Cell Dev Biol 1988). Strong shearing forces induced by rubbing endothelial cells with a balloon cause an increase in cytoplasmic Ca²⁺ concentrations (Biorheology 1994). A relatively weak shearing force, such as the shear stress generated by fluid flow, requires the presence of extracellular ATP to induce a Ca²⁺ response, and at several hundred nanomolar ATP, intracellular Ca²⁺ concentrations increase in a shear-stress-dependent

manner (BBRC 1991, 1993). Flow-induced Ca²⁺ responses generally start at a locus at the cell edge and propagate throughout the entire cell in the form of a Ca²⁺ wave (Fig. 3). The initiation locus corresponds precisely to caveola-rich cell edges (Proc Natl Acad Sci 1998). We recently found that a subtype of ATP-gated cation channel, the P2X4 receptor, is expressed in human vascular endothelial cells and that P2X4 receptors play a crucial role in the shear stress-dependent Ca²⁺ response (Am J Physiol 2000, Circ Res 2000).

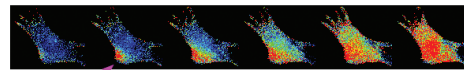

Fig. 3. A flow-induced Ca²⁺ wave in an endothelial cell.

In vivo analysis of blood flow effects

Blood flow effects on capillary permeability to macromolecules and angiogenesis have been investigated in vivo by intravital microscopy. We developed a new intravital slit-laser microscanning method to quantitatively measure permeability to fluorescently labeled proteins at the distal end of arterioles, the middle of capillaries and the proximal end of venules in rabbit skeletal muscle tissue (Microvasc Res 1995, 1997). Permeability has been shown to increase with blood flow, indicating that shear stress regulates capillary protein permeability (Jpn J Physiol 1991, 1992). We also investigated the relationship between capillary blood flow and tissue oxygen demand (Microvasc Res 1985). We observed that increases in blood flow, which were induced by arterio-venous shunt or administration of a-blocker, augmented the formation and development of new capillaries (Microvasc Res 1998). Our computer simulations have demonstrated that formation of capillary networks in mammals corresponds well to an optimum model calculated from the oxygen supply efficiency in tissues (Microvasc Res 1995). An intravital laser microscope that utilizes a phosphorescence quenching technique was recently developed to determine both microvascular and interstitial oxygen concentrations (J Appl Physiol 2001).

Current Research

Ongoing research in our laboratory include projects designed to 1) identify molecules that function as a flow sensor or shear-stress sensor in endothelial cells, 2) analyze endothelial genes that respond to shear stress, 3) investigate effects of shear force on the differentiation of endothelial progenitor cells, 4) study the microcirculation.

Flow-sensing molecules: Our recent studies have revealed that endothelial cells convert information on shear stress into changes in intracellular Ca²⁺ concen-

trations, and that P2X4 purinoceptors and their ligand ATP play an important role in the Ca^{2+} signaling. To examine the role of P2X4 receptors as flow-sensors, P2X4 cDNA was transfected into human embryonic kidney (HEK) cells, and cell lines that stably express P2X4 receptors were established. As shown in Fig. 4, the control HEK cells did not show any Ca^{2+} response to shear stress, whereas HEK cells that stably expressed P2X4 receptors showed a shear stress-dependent Ca^{2+} response. Thus, ectopic expression of P2X4 receptors made the HEK cells sensitive to flow, suggesting that P2X4 receptors function as a flow sensor. More recently, it has been demonstrated that endothelial cells release ATP in response to shear stress, and the endogenously released ATP is involved in the activation of P2X4 receptors. Shear stress-sensing mechanisms are currently being investigated in terms of ATP release.

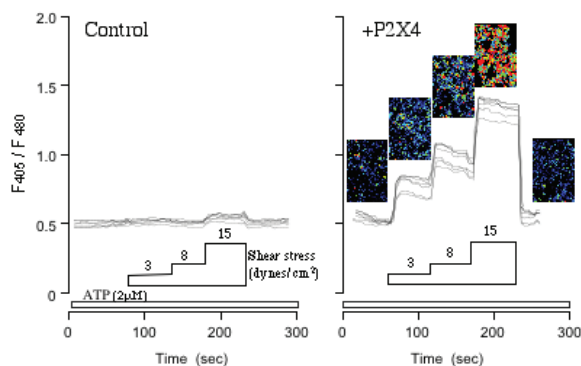

Fig. 4. P2X4 cDNA transfection makes HEK cells sensitive to shear stress.

Shear-stress-responsive genes: A high throughput genomic analysis of gene expression using DNA microarrays has been used to gain a more complete appreciation of the extent and biologic significance of endothelial activation by shear stress. Comparison of the transcriptional activity of approximately 6,000 unique genes has revealed that laminar shear stress up- or down-regulates the expression of approximately 4% of the genes examined in endothelial cells. Turbulent shear stress, which is closely related to the conditions under which atherosclerosis develops, changed the expression of about 1.5% of the genes examined. These genes included many of the genes known to function in vascular remodeling, such as genes encoding plasminogen activator, transforming growth factor and metalloproteinase. Attention is now focused on the role of these shear stress responsive genes in atherogenesis.

Effects of shear force on cell differentiation: Endothelial progenitor cells (EPCs) have recently been found to circulate in blood vessels, migrate into tissues, and participate in neovascularization, and we

recently observed that shear stress augments proliferation, differentiation, and tube-formation by EPCs. This means that mechanical forces can manipulate the differentiation of EPCs. These techniques are of potential use in clinical applications, such as in the development of tissue-engineered vessels and cell therapy for ischemic vascular diseases.

Microcirculation study: Oxygen-sensing molecules that play an important role in the regulation of vascular resistance are now being investigated, and an in vivo optical method has been developed to monitor pO₂ distribution in skeletal muscle arterioles. We have observed a significant drop in pO₂ in the arterioles and a large pO₂ gradient in the arteriolar walls, indicating that the endothelial cells and/or smooth muscle cells of arterioles may consume much more oxygen than expected. We are also developing an in situ vascular Ca^{2+} -imaging system to explore the cellular mechanism of the effects of flow and hypoxia on vascular tone.

Future Prospects

We intend to expand our research vascular biomechanics research to research on tissue engineering, atherosclerosis, and the vascular physiome in the near future.

Vascular biomechanics: To elucidate the physiological or pathophysiological significance of shear stress, shear stress-sensing molecules will be identified and knockout mice will be produced. Novel drugs that can modulate the shear stress sensors will be developed and applied to the treatment of vascular diseases.

Tissue engineering: Techniques for manipulating cell functions by mechanical forces will be developed and applied to the preparation of tissue-engineered blood vessels. A technique that allows reconstitution of endothelial progenitor cells to a 3-dimensional, capillary-like structure under flow conditions will be used to produce engineered capillary network tissue. The capillary module will be expanded to an innovative tissue engineering approach to produce blood-vessel-containing engineered tissues, such as liver and myocardial tissue.

Atherosclerosis research: Athero-prone or -protective genes will be identified among genes that respond to turbulent shear stress. An in vitro model of tissue-engineered atheroma will be established by arranging conditions, such as genetic background, hemodynamics, and lipids related to atherosclerosis. The results of these studies may be useful in develop-

ing a novel therapy for atherosclerosis.

Vascular physiome: The term “physiome” is derived from “physio- (life)” and “-ome” (as a whole), and means the quantitative and integrated description of physiological functions based on information on the genome, and proteome, and bioinformatics. Mechanical forces generated in blood vessels regulate vascular growth and remodeling in the human body. An integrative description, including modeling, of the mechanical force-mediated vascular controlling system will be conducted, and this is called the “vascular physiome”.

Research Grants

1. Grants-in-Aid for Scientific Research from the Japanese Ministry of Education, Culture, Sports, Science and Technology
Basic Research (A) 1995-1996 23,000, 000 Yen
2. Grants-in-Aid for Scientific Research from the Japanese Ministry of Education, Culture, Sports, Science and Technology
Basic Research (A) 1997-1998 21,500, 000 Yen
3. Grants-in-Aid for Scientific Research from the Japanese Ministry of Education, Culture, Sports, Science and Technology
Basic Research (A) 1999-2000 27, 900, 000 Yen
4. Special Coordination Funds for Promoting Science and Technology from the Japanese Ministry of Education, Culture, Sports, Science and Technology
1998-2002 28, 000, 000 Yen
5. Grants-in-Aid for Scientific Research from the Japanese Ministry of Education, Culture, Sports, Science and Technology
Basic Research (A) 2001-2002 28, 195, 000 Yen

Select Publications

1. M. Isshiki, J. Ando, K. Yamamoto, T. Fujita, Y. Ying, R.G.W. Anderson: Sites of Ca^{2+} wave initiation move with caveolae to the trailing edge of migrating cells. *J. Cell Sci.* 115:475-484, 2002
2. R. Korenaga, K. Yamamoto, N. Ohura, T. Sokabe, A. Kamiya, and J. Ando: Sp1-mediated downregulation of P2X4 receptor gene transcription in endothelial cells exposed to shear stress. *Am. J. Physiol Heart Circ. Physiol.* 280: H2214-H2221, 2001
3. M. Shibata, S. Ichioka, J. Ando, and A. Kamiya: Microvascular and interstitial PO₂ measurements in rat skeletal muscle by phosphorescence quenching. *J. Appl. Physiol.* 91: 321-327, 2001
4. S. Kato, J. Ando, and T. Matsuda: mRNA expression on shape-engineered endothelial cells: Adhesion molecules ICAM-1 and VCAM-1. *J. Biomed. Mater. Res.* 54:366-372, 2001
5. M. Negishi, D. Lu, Y-Q Zhang, Y. Sawada, T. Sasaki, T. Kayo, J. Ando, T. Izumi, M. Kurabayashi, I. Kojima, H. Masuda, and T. Takeuchi: Upregulatory

- expression of furin and Transforming growth factor- β by fluid shear stress in vascular endothelial cells. *Arterioscler Thromb Vasc Biol.* 21:785-790, 2001
6. K. Yamamoto, R. Korenaga, A. Kamiya, and J. Ando: Fluid shear stress activates Ca^{2+} influx into human endothelial cells via P2X4 purinoceptors. *Circ. Res.* 87:385-391, 2000
 7. K. Yamamoto, R. Korenaga, A. Kamiya, Z. Qi, M. Sokabe, and J. Ando: P2X4 receptors mediate ATP-induced calcium influx in human vascular endothelial cells. *Am. J. Physiol Heart Circ. Physiol.* 279:H285-H292, 2000
 8. J. Ando, R. Korenaga, and A. Kamiya: Shear Stress-Dependent Regulation of Endothelial Cell Functions. In “New Frontier in Vascular Biology; Thrombosis & Hemostasis”, K. Suzuki et al. eds., Eibun Press, Osaka, pp199-215, 2000
 9. J. Ando, R. Korenaga, and A. Kamiya: Flow-induced endothelial gene regulation. In “Mechanical Forces and the Endothelium”, P.I. Lelkes ed., Harwood Academic Publishers, London, pp111-126, 1999
 10. M. Nagase, J. Abe, K. Takahashi, J. Ando, S. Hirose, and T. Fujita: Genomic organization and regulation of expression of the lectin-like oxidized low-density lipoprotein receptor (LOX-1) gene. *J. Biol. Chem.* 273:33702-33707, 1998
 11. T. Murase, N. Kume, R. Korenaga, J. Ando, T. Sawamura, T. Masaki, and T. Kita: Fluid shear stress transcriptionally induces lectin-like oxidized LDL receptor-1 in vascular endothelial cells. *Circ. Res.* 83:328-333, 1998
 12. K. Masatugu, H. Itoh, T-H. Chun, Y. Ogawa, N. Tamura, J. Yamashita, K. Doi, M. Inoue, Y. Fukunaga, N. Sawada, T. Saito, R. Korenaga, J. Ando, and K. Nakao: Physiologic shear stress suppresses endothelin-converting enzyme-1 expression in vascular endothelial cells. *J. Cardiovasc. Pharmacol.* 31: S42-S45, 1998
 13. M. Isshiki, J. Ando, R. Korenaga, H. Kogo, T. Fujimoto, T. Fujita, and A. Kamiya: Endothelial Ca^{2+} waves preferentially originate at specific loci in caveolin-rich cell edges. *Proc. Natl. Acad. Sci. U.S.A.* 95: 5009-5014, 1998
 14. H. Watanabe, R. Takahashi, X-X. Zhang, Y. Goto, H. Hayashi, J. Ando, M. Isshiki, M. Seto, H. Hidaka, I. Niki, and R. Ohno: An essential role of myosin light-chain kinase in the regulation of agonist- and fluid-flow-stimulated Ca^{2+} influx in endothelial cells. *FASEB J* 12: 341-348, 1998
 15. K. Kosaki, J. Ando, R. Korenaga, T. Kurokawa, and A. Kamiya: Fluid shear stress increases the production of granulocyte-macrophage colony-stimulating factor by endothelial cells via mRNA stabilization. *Circ. Res.* 81:794-803, 1998
 16. S. Ichioka, M. Shibata, K. Kosaki, Y. Sato, K. Harii, and A. Kamiya: In vivo measurement of morphometric hemodynamic changes in the microcirculation during angiogenesis under chronic α 1-adrenergic blocker treatment. *Microvasc. Res.* 55: 165-174, 1998

17. Y. Takada, C. Kato, S. Kondo, R. Korenaga, and J. Ando: Cloning of cDNAs encoding G protein-coupled receptor expressed in human endothelial cells exposed to fluid shear stress. *Biochem. Biophys. Res. Commun.* 240: 737-741, 1997
18. R. Korenaga, J. Ando, K. Kosaki, M. Isshiki, Y. Takada, and A. Kamiya: Negative transcriptional regulation of the VCAM-1 gene by fluid shear stress in murine endothelial cells. *Am. J. Physiol.* 273: C1506-C1515, 1997
19. T. Chun, H. Itoh, Y. Ogawa, N. Tamura, K. Takaya, T. Igaki, J. Yamashita, K. Doi, M. Inoue, K. Masatsugu, R. Korenaga, J. Ando, and K. Nakao: Shear stress augments expression of C-type natriuretic peptide and adrenomedulin. *Hypertension* 29:1296-1302, 1997
20. M. Miyasaka, H. Kawashima, R. Korenaga, and J. Ando: Involvement of selectins in atherogenesis: A primary or secondary event? *Atherosclerosis IV: Recent Advances in Atherosclerosis Research*, New York Academy of Sciences 811:25-35, 1997
21. J. Ando, H. Tsuboi, R. Korenaga, K. Takahashi, K. Kosaki, M. Isshiki, T. Tojo, Y. Takada, and A. Kamiya: Differential display and cloning of shear stress-responsive messenger RNAs in human endothelial cells. *Biochem. Biophys. Res. Commun.* 225: 347-351, 1996
22. Y. Wang, W.S. Shin, H. Kawaguchi, M. Inukai, M. Kato, A. Sakamoto, Y. Uehara, M. Miyamoto, N. Shimamoto, R. Korenaga, J. Ando, and T. Toyo-oka: Contribution of sustained Ca²⁺ elevation for nitric oxide production in endothelial cells and subsequent modulation of Ca²⁺ transient in vascular smooth muscle cells in coculture. *J. Biol. Chem.* 271:5647-5655, 1996
23. J. Ando and A. Kamiya: Flow-dependent regulation of gene expression in vascular endothelial cells. *Jpn. Heart J.* 37: 19-32, 1996
24. A. Kamiya and J. Ando: Responses of vascular endothelial cells to fluid shear stress: Mechanism. In "Biomechanics-Functional Adaptation and Remodeling", K. Hayashi et al. eds., Springer-Verlag, Tokyo, pp29-56, 1996
25. H. Tsuboi, J. Ando, R. Korenaga, Y. Takada, and A. Kamiya: Flow stimulates ICAM-1 expression time- and shear stress-dependently in human endothelial cells. *Biochem. Biophys. Res. Commun.* 206:988-996, 1995
26. M. Shibata, T. Kawamura, M. Sohirad, and A. Kamiya: A new fluorescence microscopy for tomographic observation of microcirculation by using dual beam slit laser illumination. *Microvasc. Res.* 49: 300-314, 1995
27. Y. Takada, F. Shinkai, S. Kondo, S. Yamamoto, H. Tsuboi, R. Korenaga, and J. Ando: Fluid shear stress increases the expression of thrombomodulin by cultured human endothelial cells. *Biochem. Biophys. Res. Commun.* 205:1345-1352, 1994
28. W. Yang, J. Ando, R. Korenaga, T. Toyo-oka, and A. Kamiya: Exogenous nitric oxide inhibits proliferation of cultured vascular endothelial cells. *Biochem. Biophys. Res. Commun.* 203:1160-1167, 1994
29. J. Ando, H. Tsuboi, R. Korenaga, Y. Takada, N. Toyama-Sorimachi, M. Miyasaka, and A. Kamiya: Shear stress inhibits the adhesion of cultured mouse endothelial cells to lymphocytes by down-regulating VCAM-1 expression. *Am. J. Physiol.* 267:C679-C687, 1994
30. J. Ando, A. Ohtsuka, Y. Katayama, R. Korenaga, C. Ishikawa, and A. kamiya: Intracellular calcium response to directly applied mechanical shearing force in cultured vascular endothelial cells. *Biorheology* 31:57-68, 1994
31. R. Korenaga, J. Ando, H. Tsuboi, W. Yang, I. Sakuma, T. Toyo-oka, and A. Kamiya: Laminar flow stimulates ATP- and shear stress-dependent nitric oxide production in cultured bovine endothelial cells. *Biochem. Biophys. Res. Commun.* 198:213-219, 1994
32. A. Kamiya and J. Ando: Fluid shear stress and vascular endothelial cell biomechanics. In "Clinical Biomechanics and Related Research", Y. Hirasawa, C.B. Sledge, S.L.-Y. Woo eds., Springer-Verlag Tokyo pp. 255-271, 1994
33. A. Kamiya, R. Korenaga, and J. Ando: Endothelial cell responses to fluid shear stress. In "Endothelium-Derived Factors and Vascular Functions", T. Masaki ed., Elsevier Science Amsterdam pp. 103-112, 1994
34. J. Ando and A. Kamiya: Blood flow and vascular endothelial cell function. *Frontiers Med. Biol. Engng* 5:245-264, 1993
35. R. Korenaga, J. Ando, A. Ohtsuka, I. Sakuma, W. Yang, T. Toyo-oka, and A. Kamiya: Close correlation between cytoplasmic Ca⁺⁺ levels and release of an endothelium-derived relaxing factor from cultured endothelial cells. *Cell Struct. Funct.* 18:95-104, 1993
36. A. Ohtsuka, J. Ando, R. Korenaga, A. Kamiya, N. Toyama-Sorimachi, and M. Miyasaka: The effect of flow on the expression of vascular adhesion molecule-1 by cultured mouse endothelial cells. *Biochem. Biophys. Res. Commun.* 193:301-310, 1993
37. J. Ando, A. Ohtsuka, R. Korenaga, T. Kawamura, and A. Kamiya: Wall shear stress rather than shear rate regulates cytoplasmic Ca⁺⁺ responses to flow in vascular endothelial cells. *Biochem. Biophys. Res. Commun.* 190:716-723, 1993
38. M. Shibata and A. Kamiya: Blood flow dependence of local capillary permeability of Cr-EDTA in the rabbit skeletal muscle. *Jpn. J. Physiol.* 42: 631-639, 1992
39. M. Shibata, M. Yoshida and A. Kamiya: Measurement of local capillary permeability in skeletal muscle by microscopic clearance method. *Jpn. J. Physiol.* 41: 725-734, 1991
40. J. Ando, A. Ohtsuka, R. Korenaga, and A. Kamiya: Effect of extracellular ATP level on flow-induced Ca⁺⁺ response in cultured vascular endothelial cells. *Biochem. Biophys. Res. Commun.* 179:1192-1199, 1991
41. O. Ono, J. Ando, A. Kamiya, Y. Kuboki, and H. Yasuda: Flow effects on cultured vascular endothelial

- and smooth muscle cell functions. *Cell Struct. Funct.* 16:365-374, 1991
42. J. Ando, S. M. Albelda, and E. M. Levine: Culture of human adult endothelial cells in liquid-liquid interfaces: A new approach to the study of cell matrix interactions. *In Vitro Cell Dev. Biol.* 27A:525-532, 1991
 43. J. Ando, A. Kawarada, M. Shibata, K. Yamakoshi, and A. Kamiya: Pressure-volume relationships of finger arteries in healthy subjects and patients with coronary atherosclerosis measured non-invasively by photoelectric plethysmography. *Jpn. Circ. J.* 55:567-575, 1991
 44. J. Ando, S. Araya, Y. Katayama, A. Ohtsuka, A. Kamiya: Flow-induced calcium response in cultured vascular endothelial cells. In "The Regulation of Coronary Blood Flow", Inoue et al. eds., Springer-Verlag Tokyo pp 230-241, 1991
 45. A. Kamiya, J. Ando, M. Shibata, and H. Wakayama: The efficiency of the vascular-tissue system for oxygen transport in the skeletal muscle. *Microvasc. Res.* 39:169-185, 1990
 46. J. Ando, T. Komatsuda, C. Ishikawa, and A. Kamiya: Fluid shear stress enhances DNA synthesis in cultured endothelial cells during repair of mechanical denudation. *Biorheology* 27:675-684, 1990
 47. J. Ando, T. Komatsuta, and A. Kamiya: Cytoplasmic calcium response to fluid shear stress in cultured vascular endothelial cells. *In Vitro Cell. Dev. Biol.* 24:871-877, 1988
 48. H. Nomura, C. Ishikawa, T. Komatsuda, J. Ando, and A. Kamiya: A disk type apparatus for applying fluid shear stress on cultured endothelial cell. *Biorheology* 25:461-471, 1988
 49. A. Kamiya, J. Ando, M. Shibata, and H. Masuda: Roles of fluid shear stress in physiological regulation of vascular structure and function. *Biorheology* 25:271-278, 1988
 50. J. Ando, H. Nomura, and A. Kamiya: The effects of fluid shear stress on the migration and proliferation of cultured endothelial cells. *Microvasc. Res.* 33:62-70, 1987
 51. M. Shibata, and A. Kamiya: Microcirculatory responses to carotid sinus nerve stimulation at various ambient O₂ tension in the rabbit tenuissimus muscle. *Microvasc. Res.* 30: 333-345, 1985

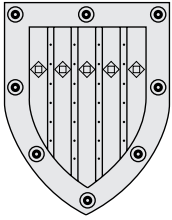

Department of Bioimaging and Biomagnetics

Outline and Research Objectives

Our department was established in 1974, with the objective of promoting research on engineering science in medicine and biology. In April, 1994, Professor Shoogo Ueno joined the University of Tokyo, replacing retiring Professor Masao Saito as chairman of the Division of Engineering Science in the Institute of Medical Electronics. In April 1997, our division re-established itself as the Department of Bioimaging and Biomagnetics. Since its establishment in 1994, the Department of Bioimaging and Biomagnetics has been engaged in research on engineering science in medicine and biology. Our department specializes in biomagnetic research, which includes the measurement of biomagnetic fields, magnetic stimulation of the brain, and the effects of magnetic fields on biological systems.

Faculties and Students

Professor and Chair	Shoogo Ueno, Dr. Eng. (1994~)
Associate Professor	Keiji Iramina, Dr. Eng.
Lecturer	Masakazu Iwasaka, Dr. Eng.
Postdoctoral Fellow	1
Graduate Student.....	15
Research Student	1
Secretary	2

Past Research and Major Accomplishments

We have studied the measurement and control of biological systems based on biomagnetism. We develop, integrate, and apply new ideas through innovative interdisciplinary research approaches. Our research topics cover wide areas in medical and biological engineering, including technology for measurement, imaging, and modelling in the following fields.

Magnetic stimulation of biological systems

Measurement of biomagnetic fields

Imaging of Electrical Information Based on Magnetic Resonance Imaging (MRI)

Effects of magnetic and electromagnetic fields on biological systems and materials

(1) Transcranial magnetic stimulation (TMS) has become an important tool for the study of the functional organization of the human brain. We developed a method of localized and vectorial magnetic stimulation using a figure eight coil (Fig.1). This method facilitates stimulation of the motor cortex of the human brain within a 5 mm resolution. We studied the cortical excitatory and inhibitory systems, using the technique of paired TMS. We observed that TMS initiates the excitation of both cortical interneurons and pyramidal tract neurons. Once the pyramidal tract neurons generate a D-wave, the excitation is unaffected by a conditioning stimulus, which has an inhibitory effect on excitability of pyramidal tract neurons.

(2) For the measurement of biomagnetic fields, we developed a SQUID (superconducting quantum interference device) system with high sensitivity that facilitates the measurement of auditory brainstem evoked magnetic fields.

We studied higher brain functions associated with short-term memory and mental rotation processes using MEG. In the functional information related to short-term memory processes, a DC-like slow wave was observed in the period between latencies of 900

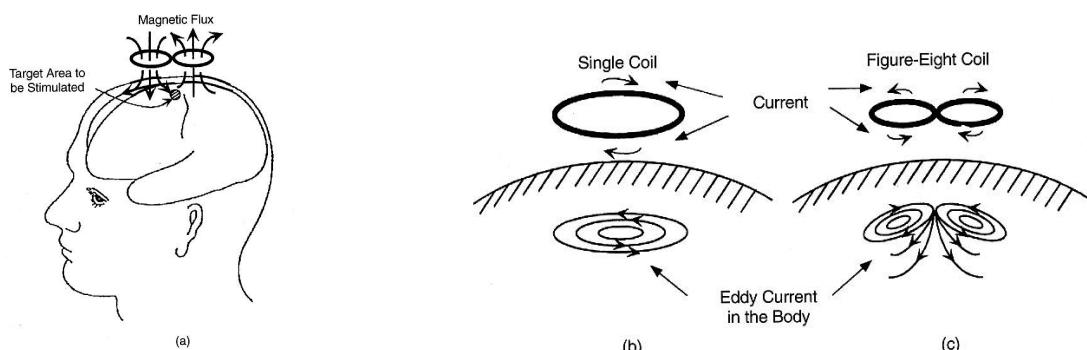

Fig.1 Basic principles of magnetic stimulation using a figure-eight coil. (a) A figure-eight coil on the head. (b) A single ring coil and an induced current pattern. (c) A figure-eight coil and an induced-current pattern.

msec and 1,500 msec during the short-term memory task. A mental rotation process requires rotation and matching of a pair of mental images. Dynamic properties of the electrical current distribution in the human brain that correspond to the early mental rotation processes were investigated.

We also focused on the relationship between MEG and fMRI and we studied the temporal and spatial responses of both hemodynamic and neuronal activities. Activation of the primary somatosensory cortex was investigated using MEG and fMRI. It was possible with fMRI to discriminate between the area of the thumb and the ring finger in the primary somatosensory cortex. In MEG measurement, however, it is difficult to discriminate between two closely located dipoles, if no initial information is given.

(3) Conventional MRI does not reveal information about the electrical properties of the body. We developed new methods to visualize neuronal current distribution and electrical-impedance distribution. The basic principle is to erase the effects of BOLD (blood oxygenation level dependent) by subtracting MRI signals with different polarities of gradient magnetic fields. Measurements were made with an echo planar imaging (EPI) sequence at 1.5 T. MRI mapping of the neuronal currents in the brain during middle finger and thumb tapping was clearly observed (Fig.2). A new method for impedance tomography was introduced, based on MRI techniques. The basic idea of impedance imaging is to use the shielding effects of induced eddy currents on spin precession.

(4) We investigated the dynamic behavior of water in high gradient magnetic fields. A superconducting magnet that produced 8 T magnetic fields at the center was used. The maximum product of the magnetic field and the gradient was $400 \text{ T}^2 / \text{m}$ at $z = 75 \text{ mm}$, where the z-axis was directed along the bore axis. A water chamber, 50 mm wide, 60 mm high, and 700 mm long was filled with distilled water. When the water chamber was inserted into the bore, we observed the phenomenon in which the water was parted, and the bottom of the water chamber was revealed. We call this phenomenon the Moses Effect. A simple calculation shows that the magnetic force acting on 100 ml of water at $20 \text{ }^\circ\text{C}$ is 0.288 N or about $1/3$ of the earth's gravity, when exposed to a magnetic field of 8 T and 50 T/m. Since the magnetic force acting on diamagnetic and paramagnetic materials moves the materials along magnetic field gradients, any kind of biological cells and materials can be manipulated by magnetic force. In contrast, when biological materials such as fibrin and collagen are exposed to uniform magnetic fields, parallel or perpendicular orientation to the magnetic field direction is attained. For example, we successfully oriented adherent cells such as smooth muscle and endothelial cells, and osteoblasts in parallel to the magnetic field direction after 8T magnetic field exposure (Fig. 3). The magnetic manipulation and alignment of cells and other biological materials has opened a new horizon in tissue engineering.

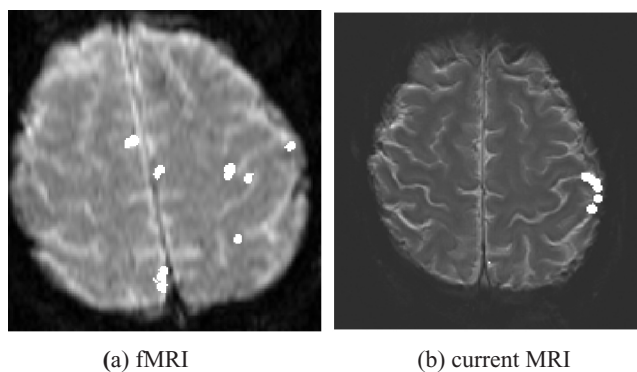

Fig.2 (a) fMRI and (b)MRI mapping of the neuronal currents in the brain during middle finger and thumb tapping.

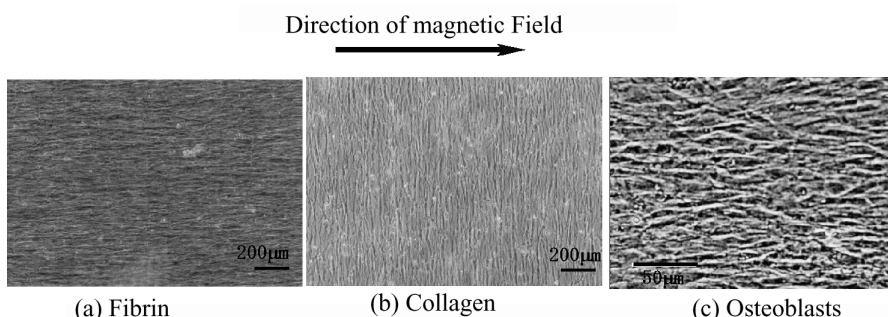

Fig.3 Magnetically oriented (a) Fibrin (b) Collagen (c) Osteoblasts under an 8T static magnetic field.

Current Research

Our department is conducting interdisciplinary research in three major areas: imaging and cognitive neuroscience, cell and tissue engineering, and the assessment of the biological effects of electromagnetic fields.

Imaging and cognitive neuroscience

Our research focuses on the development of functional brain dynamics imaging with high time resolution and high spatial resolution. The main techniques employed are TMS (transcranial magnetic stimulation), MEG (magnetoencephalography), EEG (electroencephalography), electric current imaging by MRI, and impedance imaging by MRI. These techniques are noninvasive and very useful for studying higher brain functions of humans such as memory and cognition.

We developed a 2-channel repetitive transcranial magnetic stimulator and an EEG measurement system that combines TMS. We were able to non-invasively evaluate the cortical reactivity and functional connections between different brain areas. We used TMS to investigate memory encoding and retrieval, particularly the role of the dorsolateral prefrontal cortex in associative memory for visual patterns. TMS disrupts associative learning for abstract patterns over the right frontal area, which suggests that the participating cortical networks may be lateralized in accordance with classic concepts of hemispheric specialization.

We compared current density distributions in electroconvulsive therapy (ECT) and TMS using the finite element method. While the skull significantly affected current distributions in ECT, TMS efficiently induced eddy currents in the brain. Our results will support clinical investigations to determine the electrode and coil positions that maximize efficacy.

To investigate the safety aspects of TMS on the brain, functional and anatomical changes in the brain were investigated. Our initial experimental results revealed that TMS does not affect the fEPSP (field excitatory post synaptic potential) of the rat hippocampus.

We introduced a new method of conductivity tensor imaging using diffusion-weighted MRI to obtain conductivity tensor distribution of the brain. Diffusion-weighted images were acquired with motion probing gradients (MPGs) applied in three directions. Conductivities in each MPG direction were calculated from the fast component and the fraction of the fast component, and two-dimensional conductivity tensor was estimated. We also proposed a new method of electrical current imaging based on the frequency shift technique of MRI.

In another study, we investigated a method for tissue characterization using diffusion tensor analysis

and applied external electrical currents.

Magnetophysiology

We studied the ischemic myocardial muscles of rat using a high-resolution DC-SQUID magnetometer. The information about the ischemic myocardium region and changes of function were obtained by caridiomagnetic imaging.

We also measured the magnetic fields associated with end plate potentials induced from neuromuscular junctions of frogs. Biomagnetic measurements of synaptic transmission processes by micro SQUID systems are useful for the physiological and pharmacological studies such as stimulus-excitation-contraction coupling.

Biological effects of electromagnetic fields

We investigated the effects of strong magnetic fields (8T, 14T) on the structure, organization, and function of biological systems and materials, and the possible medical and therapeutic applications of magnetic fields.

The effects of 14 T strong static magnetic fields on the functional properties of biological materials, such as proteins, oxygen molecules, and water were also investigated. (1) A spectrum profile of hemoglobin inside red blood cells indicated conformational changes depending on the magnetic flux density. (2) Magnetic field exposure initiated platelet aggregation with the aid of collagen and accelerated the aggregation of platelets and fibrin. (3) Leukemia cell proliferation was decreased by an 8 T magnetic field, as a result of behavioural changes of dissolved oxygen during exposure. (4) Magnetic fields inhibited bioluminescence of luciferin and luciferase in both in vitro and in vivo experiments. Possible applications of magnetic fields for the control of biochemical reactions were suggested.

We explored the possible medical applications of magnetically oriented collagen. Magnetically aligned collagen provides a scaffold for smooth muscle cells (A7r5), osteoblasts (MC3T3), nerve cells (PC12 and Schwann cells), and blood vessels on which to grow, and it directs the growth to a specific direction. Further experiments, however, demonstrated the magnetic orientation of adherent cells without collagen guidance after long-term exposure to static magnetic fields. Further studies must be carried out to clarify the detailed mechanisms which include the diamagnetic properties of the cells. Our findings may lead to clinically viable treatments of bone fractures and bone defects as well as medical engineering applications such as nerve regeneration.

With the ever-increasing worldwide use of mobile phones in recent years, social concerns and anxieties have been raised about the possible detrimental

effects on human health. We investigated the effects of high frequency electromagnetic field exposure on rats.

We investigated the effects of exposure to the standard frequency of electromagnetic waves used for cellular phones in Japan (1,439 MHz) on the permeability of the blood brain barrier (BBB), brain morphological changes, body mass fluctuations, and cognitive functions and memory restoration of male Sprague-Dawley rats.

Our results suggest that exposure to a TDMA field at levels much stronger than emitted by cellular phones do not affect the learning and memory processes when there are no thermal effects. In our most recent study, however, we investigated the effects of 1439 MHz TDMA electromagnetic fields on sleep disturbance or melatonin synthesis in rats. The pineal melatonin level decreased with short-term TDMA exposure, whereas the serum melatonin level was unchanged. Short-term TDMA exposure may inhibit pineal melatonin synthesis in this limited experiment. Further studies are currently underway to confirm and explain our initial results.

Future Prospects

In the next 3.5 years, we hope to achieve significant progress in our three major areas of research: imaging and cognitive neuroscience, cell and tissue engineering, and the assessment of biological effects of electromagnetic fields.

By determining how the brain works, from the level of neurons to the relationships between complex neural networks, a myriad of medical, therapeutic and engineering applications will be developed. The combination of neuromagnetic imaging techniques will allow us to understand the dynamic interactions between individual cells and larger neural networks that give rise to the patterns of electrical activity associated with higher brain function. We hope to determine where and how signals for various higher cognitive processes arise within the brain using TMS, EEG, MEG, and MRI. The development of new imaging methods to better visualize brain activity will also provide a wealth of new information. For example, our new MR imaging techniques will be helpful for the early detection of neurological disorders, such as acute cerebral infarctions. Ultimately, we hope the information retrieved will uncover the roots of neurological and psychiatric diseases.

By determining the effects of electromagnetic fields on biological materials and systems and understanding the mechanisms involved, we can develop many potentially viable cell and tissue engineering applications. For example, we will continue our research to determine whether repetitive TMS regen-

erates or prevents damage to injured rat hippocampal CA3 cells as well as our study on the magnetic orientation of Schwann cells for nerve regeneration. Researches on the cellular responses to magnetic fields will also proceed by analyzing the genetic responses as well as the morphological changes of cells under strong static magnetic fields. Magnetically induced cytoskeleton displacement in an intact cell will be observed during both long and short-term magnetic field exposures. A new technique for the remote handling of macromolecules in living systems by electromagnetic forces will also be developed.

Research Grants

1. 2000-2004 Grant-in Aid for Specially Promoted Research, Ministry of Education, Science, Sports, Culture and Technology, Japan (No. 12002002.) 386,000,000Yen "Study of Dynamic Brain Function using Transcranial Magnetic Stimulation and Neuronal Current Imaging"
2. 1998-2000 Grant-in Aid for Scientific Research (A), Ministry of Education, Science, Sports, Culture and Technology, Japan (No. 10308037) 35,800,000Yen "Control of living systems by strong magnetic fields"

Select Publications

1. Iramina K, Maeno T, Kowatari Y, and Ueno S: Effects of transcranial magnetic stimulation on EEG activity. *IEEE Transactions on Magnetics*, 38(5): in press, 2002.
2. Huang SF, Iramina K, Yumoto M, and Ueno S: Visual-evoked magnetic fields associated with geometric and phonetic discrimination. *IEEE Transactions on Magnetics*, 38(5): in press, 2002.
3. Kotani H, Kawaguchi H, Shimoaka T, Iwasaka M, Ueno S, Ozawa H, Nakamura K, and Hoshi K: Strong static magnetic field stimulates bone formation to a definite orientation in vitro and in vivo. *Journal of Bone and Mineral Research*, 17(10): 1814-1821, 2002.
4. Hong B, Kuwaki T, Kihwan J, Kumada M, Akai M, and Ueno S: Changes in blood pressure and heart rate by repetitive transcranial magnetic stimulation in rats. *Neuroscience Letters*, 329: 57-60, 2002.
5. Sekino M and Ueno S: Comparison of current distributions in electroconvulsive therapy and transcranial magnetic stimulation. *Journal of Applied Physics*, 91(10), 8730-8732, 2002.
6. Epstein CM, Sekino M, Yamaguchi K, Kamiya S and Ueno S: Asymmetries of prefrontal cortex in human episodic memory: Effects of transcranial magnetic stimulation on learning abstract patterns. *Neuroscience Letters*, 320(1-2): 5-8, 2002.
7. Uchida S, Goto K, Tachikawa A, Iramina K, and Ueno S: Magnetocardiographic imaging for ischemic myocardial muscles on rats. *IEICE Transactions on Information and Systems*, 65-D(1): 30-35, 2002.

8. Nijjima S and Ueno S: MEG source estimation using the fourth order MUSIC method. *IEICE Transactions on Information and Systems*, E85-D(1): 167-174, 2002.
9. Iwaki S, Tonoike M, and Ueno S: Visualization of the brain activity during mental rotation processing using MUSIC-weighted lead-field synthetic filtering. *IEICE Transactions on Information and Systems*, E85-D(1): 175-183, 2002.
10. Kasai K, Yamada H, Kamio S, Nakagome K, Iwanami A, Fukuda M, Itoh K, Koshida I, Yumoto M, Iramina K, Kato, M, and Ueno S: Brain lateralization for mismatch response to across- and within-category change of vowels. *NeuroReport*, 12(11): 2467-2471, 2001.
11. Iramina K, Kamei H, Yumoto M, and Ueno S: Effects of repetition rate of electric stimulation on MEG and fMRI signals. *IEEE Transactions on Magnetics*, 37(4): 2918-2920, 2001.
12. Iwasaka M, Yaoita M, Kono T, and Ueno S: Magnetically disturbed activity of immobilized catalase on an electrode in hydrogen-peroxide buffer. *IEEE Transactions on Magnetics*, 37(4): 2941-2943, 2001.
13. Iwasaka M, Miyakoshi J, and Ueno S: Optical absorbance of hemoglobin and red blood cell suspensions under magnetic fields. *IEEE Transactions on Magnetics*, 37(4): 2906-2908, 2001.
14. Iwasaka M, Miyakoshi J, and Ueno S: Magnetophoresis of diamagnetic cells and microorganisms in a culture medium. *IEEE Transactions on Magnetics*, 37(4): 2644-2646, 2001.
15. Ogiue-Ikeda M., Kotani H, Iwasaka M, Sato Y, and Ueno S: Inhibition of leukemia cell growth under magnetic fields of up to 8T. *IEEE Transactions on Magnetics*, 37(4): 2912-2914, 2001.
16. Umeno A, Kotani H, Iwasaka M, and Ueno S: Quantification of adherent cell orientation and morphology under strong magnetic fields. *IEEE Transactions on Magnetics*, 37(4): 2909-2911, 2001.
17. Hayashi R, Imaizumi S, Mori K, Niimi S, Ueno S, and Kiritani S: Elicitation of N400m in sentence comprehension due to lexical prosody incongruity. *NeuroReport*, 12(8): 1753-1756, 2001.
18. Iwasaka M, Takeuchi M, and Ueno S: Aggregation of blood platelets in static magnetic fields. *IEEE Transactions on Magnetics*, 36(5): 3721-3723, 2000.
19. Uchida S, Iramina K, Goto, K, and Ueno S: A comparison of iterative minimum norm estimation and current dipole estimation for magnetic field measurements from small animals. *IEEE Transactions on Magnetics*, 36(5): 3724 -3726, 2000.
20. Tsuda R and Ueno S: Source localization of visually evoked magnetic fields to stimuli in apparent motion. *IEEE Transactions on Magnetics*, 36(5): 3727-3729, 2000.
21. Tsurita G, Nagawa H, Ueno S, Watanabe S, and Taki M: Biological and morphological effects on the brain after exposure of rats to a 1439 MHz TDMA field. *Bioelectromagnetics*, 21: 364-371, 2000.
22. Ichioka S, Minegishi M, Iwasaka M, Shibata M, Nakatsuka T, Harii K, Kamiya A, and Ueno S: High-intensity static magnetic fields modulate skin microcirculation and temperature *in vivo*. *Bioelectromagnetics*, 21: 183-188, 2000.
23. Liu R and Ueno S: Calculating the activating function of nerve excitation in inhomogeneous volume conductor during magnetic stimulation using the finite element method. *IEEE Transactions on Magnetics*, 36(4): 1796-1799, 2000.
24. Kotani H, Iwasaka M, Ueno S, and Curtis A: Magnetic orientation of collagen and bone mixture. *Journal of Applied Physics*, 87(9): 6191-6193, 2000.
25. Uchida S, Iramina K, Goto K, and Ueno S: Current source imaging for high spatial resolution magneto-cardiography in normal and abnormal rat cardiac muscles. *Journal of Applied Physics*, 87(9): 6205-6207, 2000.
26. Tsurita G, Ueno S, Tsuno N, Nagawa H, and Muto T: Effects of exposure to repetitive pulsed magnetic stimulation on cell proliferation and expression of heat shock protein 70 in normal and malignant cells. *Biochemical and Biophysical Research Communications*, 261(3): 689-694, 1999.
27. Iramina K, Kamei H, Uchida S, Kato T, Ugurbil K, Yumoto M, and Ueno S: Effects of stimulus intensity on fMRI and MEG somatosensory cortex using electrical stimulation. *IEEE Transactions on Magnetics*, 35(5): 4106-4108, 1999.
28. Kamei H, Iramina K, Yoshikawa K, and Ueno S: Neuronal current distribution imaging using magnetic resonance. *IEEE Transactions on Magnetics*, 35(5): 4109-4111, 1999.
29. Yukawa Y, Iriguchi N, and Ueno S: Impedance magnetic resonance imaging with external AC field added to main static field. *IEEE Transactions on Magnetics*, 35(5): 4121-4123, 1999.
30. Uchida S, Iramina K, Goto K, and Ueno S: High-resolution magnetocardiography for the study of dynamic propagation of excitation sites in rat cardiac muscles. *IEEE Transactions on Magnetics*, 35(5): 4124-4126, 1999.
31. Nakagawa S and Ueno S: Measurements and source estimations of extremely low frequency brain magnetic fields in a short-term memory task by a whole-head neurogradiometer. *IEEE Transactions on Magnetics*, 35(5): 4130-4132, 1999.
32. Nakagawa S, Ueno S, and Imada T: Changes in parameters of auditory evoked magnetic fields with click train patterns. *Journal of Applied Physics*, 85(8): 5708-5710, 1999.
33. Sugase Y, Yamane S, Ueno S, and Kawano K: Global and fine information coded by single neurons in the temporal visual cortex. *Nature*, 400(6747): 869-873, 1999.
34. Iwaki S, Ueno S, Imada T, and Tonoike M: Dynamic cortical activation in mental image processing revealed by biomagnetic research. *NeuroReport*, 10: 1793-1797, 1999.

35. Ueno S: Biomagnetic approaches to studying the brain. *IEEE Engineering in Medicine and Biology*, 18: 108-120, 1999.
36. Ueno S and Iriguchi N: Impedance magnetic resonance imaging: a method for imaging of impedance distributions based on magnetic resonance imaging. *Journal of Applied Physics*, 83(11): 6450-6452, 1998.
37. Iramina K, Hong B, Uchida S, Goto K, and Ueno S: Measurements of biomagnetic fields using a high-resolution dc superconducting quantum interference device magnetometer. *Journal of Applied Physics*, 83(11): 6465-6467, 1998.
38. Iwaki S and Ueno S: Weighted minimum-norm source estimation of magnetoencephalography utilizing the temporal information of the measured data. *Journal of Applied Physics*, 83(11): 6441-6443, 1998.
39. Iwasaka M and Ueno S: Structure of water molecules under 14T magnetic field. *Journal of Applied Physics*, 83(11): 6459-6461, 1998.
40. Mihara H, Iriguchi N, and Ueno S: A method of rf inhomogeneity correction in MR imaging. *MR Materials in Physics, Biology and Medicine*, 7: 115-120, 1998.
41. Iwasaka M, Takeuchi M, Ueno S, and Tsuda H: Polymerization and dissolution of fibrin under homogenous magnetic field at 14T. *Journal of Applied Physics*, 83(11): 6453-6455, 1998.
42. Iwasaka M and Ueno S: Bioluminescence under static magnetic fields. *Journal of Applied Physics*, 83(11): 6465-6458, 1998.
43. Ichioka S, Iwasaka M, Shibata M, Harii A, Kamiya A, and Ueno S: Biological effects of static magnetic fields on the microcirculatory blood flow *in vivo*: a preliminary report. *Medical and Biological Engineering & Computing*, 36: 91-95, 1998.
44. Kobayashi M, Hyodo A, Kurokawa T, and Ueno S: The first component of polyphasic motor evoked potentials is resistant to suppression by paired transcranial magnetic stimulation in humans. *Journal of the Neurological Sciences*, 159: 166-169, 1998.
45. Iramina K, Yumoto M, Kamei H, and Ueno S: Measurement of somatosensory evoked response using functional MR images and MEG. *IEEE Transactions on Magnetics*, 33(5): 4260-4262, 1997.
46. Iwaki S and Ueno S: A high-speed estimation of internal electrical sources in the human brain from the MEG measurement using subspace scanning with multiple scanning resolutions. *IEEE Transactions on Magnetics*, 33(5): 4272-4274, 1997.
47. Kobayashi M, Ueno S, and Kurokawa T: Importance of soft tissue inhomogeneity in magnetic peripheral nerve stimulation mechanism. *Electroencephalography and Clinical Neurophysiology*, 105: 406-413, 1997.
48. Iramina K and Ueno S: Source estimation of spontaneous MEG activity and auditory evoked responses in normal subjects during sleep. *Brain Topography*, 8(3): 297-301, 1996.
49. Fujiki M, Isono M, Hori S, and Ueno S: Corticospinal direct response to transcranial magnetic stimulation in humans. *Electroencephalography and Clinical Neurophysiology*, 101: 48-57, 1996.
50. Iwasaka M, Ueno S, and Tsuda H: Measurement of clottability of fibrin polymers using magnetic orientation. *Journal of Applied Physics*, 79(8): 4708-4710, 1996.

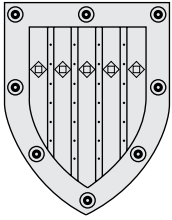

Department of Biosystem Construction & Control

Outline and Research Objective

This department was established in 1964 as Division of Clinical Medicine in Institute of Medical Electronics for research and development of the advanced diagnostic and therapeutic instruments for the clinical medicine and their related technologies. The education to train the leaders of biomedical engineer and clinical engineer is its another important role. The first The name of the department and institute has been changed as shown above since April 1, 1997 with the structural reform of Faculty of Medicine.

This department has been cooperating with Division of Artificial Biomechanism, Research Center for Advanced Science and Technology (RCAST) presided by Associate Prof. Chinzei and Division of advanced Biomedical Engineering & Life Science, Center for Cooperative Research (CCR) presided by Prof. Mabuchi in the recent 10 years. Both laboratories, 10 Km distant, are connected with a personal microwave television system for all-day long to exchange many information, to have a periodical research meeting and to monitor the artificial heart animals from each other.

Our research fields are artificial heart, artificial valve, biomaterials, medical laser, medical thermography, measurement instruments and sensors, and micromachine.

Faculties and Students

Professor and Chair	Kou Imachi, Ph. D.(1993 -)
Associate Professors	Yusuke Abe, M. D., Ph. D.
Lecturer	Takashi Isoyama, Ph. D.
Associate	1
Technical Assistant	1
Graduate Students	2
Guest Researchers	6
Secretary	1
Professor Emeritus	Kazuhiko Atsumi, M. D., Ph. D., Iwao Fujimasa, M. D., Ph. D.

Past Research and Major Accomplishments

Professor Imachi joined to Institute of Medical Electronics in 1970 as a student of Graduate School of Medicine, University of Tokyo, after he got the master's degree of mechanical engineering at Kyoto University and spent 2 years at Hitachi Chemical Co. Ltd. as a chemical plant research engineer. Since that time he has been studying biomedical engineering and he became Associate in 1972, Associate professor in 1987 and Professor in 1993. The past research and major accomplishments performed by him and his group are shown in the following;

1. Artificial heart

The artificial heart(AH) study is world famous research project having a long history since 1959. Almost all the research fields such as driving mechanism, blood pump, artificial valve, materials, measure-

ment & control method, circulatory physiology and pathophysiology have been developed and studied. They are summarized in Figure1.

Our peculiar policy for AH research is shown in Table 1. According to the policy, we have been approaching to an implantable total AH(TAH) with quite different way from other groups and have obtained many accomplishments summarized in Table 2. Among these accomplishments, trying 4 types of TAH, development of jellyfish valve, device of 1 / R control method, 3 times of the world longest survival record under TAH goat, proposal of many pathophysiological hypothesis, and invention of undulation pump are the most unique and remarkable outputs.

2. Biomaterials

Concerning the biomaterials, the mechanism of thrombus formation and calcification on the medical polymer surfaces, especially in the artificial heart blood pump and on polymer valve have been studied. The evaluation of biocompatibility of many biomaterials was also important task.

3. Medical laser

Medical laser research in this laboratory was started in 1965. Ruby laser, CO₂ laser, Nd-YAG laser, excimer laser, argon laser, semiconductor laser have been studied. Laser scalpel, laser coagulator, laser endoscopes for percutaneous intradiscal laser nucleotomy, for colenary laser angioplasty and for percutaneous mitral valvotomy, were developed. As

Fig. 1 History of TAH in The University of Tokyo

	1960	1970	1980	1990	2000
Material	natural rubber				
	silicone rubber	PVC paste		(surface coating)	
Blood pump	pseudo neo-intima		Avcothane, Cardiothane	KP13	KIII
			furuorinated PU		
Valve	door type	pneumatic driven	Bjork-shiley		
	ball/disc	OED	OED with heparine gland	jellyfish	
Drive unit	motor/cam/bellows/hydraulic			liquid gas driven	
	motor/roller/tube		computer control pressure generator	FTPTAH	
Control	pneumatic driven	fluidics		undulation pump TAH	
	R & L balance	blood pressure wave form with computer		predictive control	
Animal	dog	sheep	rabbit		
		goat	calf		
TAH type	0.2 0.6	1.1	30 100	174 344	532
	0.5 1.0		6.3 9.6 54	130 288	360
	TITAH	FTAH	HTAH	TRAH	ITAH

Table 1 The policy of AH research in our laboratory

- Never copy the foreign countries project (respect the other person's originality)
- Don't be captured by the existing laws and theories (there is no common sense in interdisciplinary field research)
- Don't cling to your background
- Have always hypothesis
- Don't change the system until it runs into a stone wall
- Don't change more than 2 parameters at once
- Try to make all the things by yourself (Speed is the most important)
- Don't hesitate to publish the negative data (truth is hidden in the negative data)

Table2 Accomplishments in AH research in this laboratory

- Four types of TAH,: FTAH(1963-1980), HTAH(1977-1982), TRA(1981-1996) and ITAH(1996-)
- FTAH: TAH with fibrillated natural heart
- HTAH: Hybrid TAH, Natural heart is beating but trunks of PA and Ao is occluded
- TRAH: Total replacement AH, NH is resected and 2 pumps are placed on the chest wall
- ITAH: Implantable TAH, All the components except energy source are implanted
- Home made artificial valves
 - OED(Oblique elliptical seat door type) valve 1971 - 1978
 - Jellyfish valve: polymer membrane valve(1987 -)
- Control method
 - Fixed cardiac output
 - Fixed cardiac output with electrical stimulation
 - 1 / R control
- World longest survival record with TAH in goat
 - 1980: 288 days with HTAH
 - 1984: 344 days with TRA
 - 1995: 532 days with TRA under 1 / R control
- Hypothesis
 - Hyper cardiac output syndrome: 1973 - 1975
 - Cardiac receptor hypothesis:: 1982 - 1895
 - Calcification mechanism hypothesis: 1995 - 2000
- Blood pump & materials
 - Critical surface roughness to promote thrombus for mation(3 mm): 1970
 - Surface coating of segmented polyurethane on PVC: 1973 -
 - Multi-material test method of blood compatibility: 1984 - 1990
- Clinical device development
 - Pneumatic driven ventricular assist device in cooperation with Aisin Seiki & Nippon Zeon Co. Ltd.:1990 -

for the basic research, the influence of various kinds of lasers on living tissue, laser therapy for tumor and cancer, laser neurotomy, bactericidal effect of laser were investigated.

4. Medical thermography

Research of medical thermography in this laboratory was started in 1965. Since that time, many kinds of infrared thermography for clinical use has been developed in cooperation with Fujitsu, Nihon-denshi, NEC, Nihonkoden Co.Ltd, etc.. As the basic and application researches, theoretical model construction to estimate subcutaneous blood flow from thermogram, digital processing of thermogram, dynamic thermography, standardization of clinical diagnosis, thermotome, thermo-myotome, etc were studied.

5. Measurement instruments and sensors

Portable electro-magnetic flow(EMF) meter, EMF flow probe for AH, blood lactate measurement instrument, remote monitoring system of AH animals through microwave TV, implantable CCD probe to observe microcirculation were developed.

6. Micromachine

Micromachine research was started in 1987. The word "micromachine" was made in this laboratory when we began to start a society for the study of micro-mechanical system in 1988. Artificial muscle moved by vibrating energy, regenerative nerve electrode, micro-laser endoscope were studied and developed

Current Research

1. Artificial heart

Since 1996, AH project in this laboratory is focused on the development of implantable TAH in which the all components except outer battery and energy transmission system are implanted into the body and expected as the substitution of the heart transplantation. Undulation pump TAH(UPTAH) which is the most compact TAH in the world was invented(Fig. 2). Another merit of UPTAH is that it can produce any kinds of flow patterns such as pulsatile flow, continuous flow and pulsatile flow on the continuous flow, etc.. At the present stage, 6 goats survived over 1 month including 63 days as the longest. Now all the components such as blood pump, driving unit, control system, measurement system and energy transmission system are being made more compact and increased in durability and reliability. The influences of nonpulsatile flow on microcirculation and organ function are being in research. A new



Fig.2 Assembled UPTAH

project to develop an implantable ventricular assist device for clinical use for the bridge to heart transplantation has been ready to start using the undulation pump. According to our calcification hypothesis, the jellyfish valve is improved design to reduce the creep fatigue. The new designed valve proved almost 10 years durability in-vitro acceleration fatigue testor.

2. Other researches

In the laser research, handy type laser blood coagulator aiming to use in the surgical field, is being developed and evaluated in the animal experiments. The imaging of arterial blood flow distribution in the skin and organs using a high speed thermography is studying. CCD probe to observe microcirculation chronically is being made compact including focus. Regenerative nerve electrode to control artificial organs through nervous signals is improving its tissue compatibility.

3. New research

Tissue engineering research has started in this year. As the first step, valve membrane of jellyfish valve is trying to make using endothelial cell culture.

Future Prospects

The following researches are scheduled as the future projects and a part of them is already ready to start.

Development of a permanent use artificial heart to be able to substitute the heart transplantation. A rotary type undulation pump which moves magnetically suspended is begun to design.

Complete the regenerative nerve electrode and find a control algorithm of artificial organs through nervous signals.

Development distributed artificial heart system in which the artificial blood pumps are connected to each organs and tissues. Basic study to connect a small AH to a kidney has already started.

Regenerative medicine to make a whole organs from ES cells will be started aiming to shorten the growing time utilizing a biomedical engineering technologies.

Research Grants in these 5 Years

1. The Program for Promotion of Fundamental Studies in Health Science of the Organization for Pharmaceutical Safety and Research(OPSR) "The comprehensive basic research on the development of Japanese original implantable total artificial heart", Head Investigator: K. Imachi, 170,460,000yen, 1996 – 2000
2. Grant-in-Aid for Scientific Research (B)(2):"A study on long-term and continuous observation and analysis of microcirculation under artificial circulation", Top Head Investigator: K. Imachi, 16,000,000yen, 1999 – 2000
3. Grant-in-Aid for Scientific Research (A)(2): "Development of a simplified pulsatile left ventricular assist device", Head Investigator: K. Imachi, 17,200,000yen, 1999 – 2000
4. Grant-in-Aid for Scientific Research (A)(2):"Research and development of implantable artificial heart for permanent use", Head Investigator: Y. Abe, 42,600,000yen, 2000 – 2002
5. Grant-in-Aid for Scientific Research (S): "Comprehensive research for the influence of flow state of artificial heart on the living body by observation of microcirculation", Head Investigator: K. Imachi, 87,900,000yen, 2002 – 2006

Select Publications

1. K. Atsumi, Y. Sakurai, I. Fujimasa, K. Imachi, T. Nishisaka, I. Mano, H. Ohmichi, J. Mori, N. Iwai and A. Kouno: Hemodynamic analysis on prolonged survival cases (30 days and 20 days) of artificial total heart replacement, *Trans. Am. Soc. Artif. Intern. Organs*, 21,545-554, 1975.
2. I. Mano, I. Fujimasa, K. Imachi, T. Nishisaka, H. Ohmichi, J. Mori, N. Iwai, K. Atsumi, Y. Sakurai and I. Kino: Pathophysiological studies of the animals replaced with the artificial heart. Part II. Concerning liver,, gastrointestinal tract, kidney, and general discussion, *Japanese Heart Journal*, 17(3),326-337, 1976.
3. K. Imachi, I. Fujimasa, T. Nishisaka, H. Ohmichi, N. Iwai, A. Kouno, H. Miyake, and K. Atsumi:How to prevent thrombus formation in the artificial heart, *Artificial Organs*, 2(Suppl)
4. I. Fujimasa, K. Imachi, H. Ohmichi, S. Takasugi, T. Nishisaka, N. Iwai, A. Kouno, H. Miyake and K. Atsumi: A circulatory dynamic model for artificial heart control, *Artificial Organs*, 2(Suppl.), 214-216, 1978.
5. H. Ohmichi, K. Imachi, I. Fujimasa, T. Nishisaka, N. Iwai, A. Kouno and K. Atsumi: Hemodynamic and blood gas analysis in total artificial heart replaced animal during treadmill exercise, *Artificial Organs*, 2(Suppl.) 230-233, 1978.

6. K. Atsumi, I. Fujimasa, K. Imachi, N. Satoh, H. Miyake, N. Takido, N. Iwai and A. Kouno: New hybrid method of total artificial heart replacement with natural beating by coronary circulatory preservation, *Proceedings of 6th European Society for Artificial Organs*, A1-A6, 1979.
7. K. Imachi, I. Fujimasa, H. Miyake, N. Takido, M. Nakajima, K. Motomura, A. Kouno, T. Ono, and K. Atsumi:Evaluation of antithrombogenicity, durability and biocompatibility of an artificial heart system for more than 100 days, *Artificial Organs*, 5(Suppl), 423-429, 1981.
8. K. Imachi, I. Fujimasa, H. Miyake, N. Takido, M. Nakajima, A. Kouno, T. Ono, Y. Mori, S. Nagaoka, S. Kawase, T. Kikuchi, and K. Atsumi: Evaluation of polyurethane sac type blood pump after 232 and 288 days total artificial heart pumping without anticoagulant, *Trans Am. Soc. Artif. Intern Organs*, 27, 118-122, 1981
9. K. Atsumi, I. Fujimasa, K. Imachi, H. Miyake, N. Takido, M. Nakajima, A. Kouno, T. Ono, S. Yuasa, Y. Mori, S. Nagaoka, S. Kawase and T. Kikuchi: Three goats survived for 288 days, 243 days and 232 days with hybrid total artificial heart, *Trans. Am. Soc. Artif. Intern. Organs* 27, 77- 82 (1981)
10. A. Ihara, K. Motomura, M. Nakajima, K. Imachi, I. Fujimasa, and K. Atsumi: Comparative study on Medical laser system and their evaluation criteria, *LASER-TOKYO'81*(K. Atsumi et al Ed.), *The Jap Soc for Laser Med*, Tokyo, 22-25, 1981.
11. K. Atsumi, I. Fujimasa, K. Imachi, A. Miyamoto, N. Takido, M. Nakajima S. Tsukagoshi and N. Inou: Development and evaluation on cardiac ventricular assist device for clinical use, *Proceedings of ESAO*, 9, 231- 234, 1982.
12. Fujimasa, K. Imachi, H. Miyake, M. Iwatani and K. Atsumi: Thermo-blood flowmetry, microprocessor processed thermograms, *Lecture Notes in Medical Informatics*(Lindberg & Leihertz Ed.), Springer-Verlag, 222-227, 1982.
13. K. Imachi, I. Fujimasa, M. Nakajima, A. Miyamoto, N. Takido, N. Inou., S. Tsukagoshi, K. Mabuchi, K. Motomura, A. Kouno, T. Ono, and K. Atsumi: Evaluation of the metabolic state in a total artificial heart circulatory system, *Progress in Artificial Organs-1983*(Atsumi K et al Ed.), 252-256, ISAO Press, Cleveland, 1984
14. K. Imachi, I. Fujimasa, M. Nakajima, K. Mabuchi, S. Tsukagoshi, K. Motomura, A. Miyamoto, N. Takido, N. Inou, A. Kouno, T. Ono, and K. Atsumi: Overall analysis of the causes of pathophysiological problems in total artificial heart in animals by cardiac receptor hypothesis, *Trans. Am. Soc. Artif. Intern. Organs*, 30, 591-596, 1984
15. K. Atsumi, I. Fujimasa, K. Imachi and N. Nakajima: How can the total artificial heart patient be mobile and enjoy his life with an air driven system?, *Trans. Am. Soc. Artif. Intern. Organs*, 30, 86-90, 1984
16. N. Inou, I. Fujimasa, K. Imachi, A. Miyamoto, M. Nakajima, N. Takido, K. Mabuchi, S. Tsukagoshi, A.

- Kouno and K. Atsumi: Quantitative approach to determine the application time of the left ventricular assist device, *Artificial Organs*, 8(4), 458-469, 1984
17. Fujimasa, K. Imachi, Y. Kajiyama, K. Atsumi: Cardiac muscle thermo-graphy, *Recent Advances in Medical Thermology*(Francic, Ring & Phillips Ed.), Plenum Publishing, 375-378, 1984
 18. K. Atsumi, I. Fujimasa, K. Imachi, M. Nakajima, S. Tsukagoshi, K. Mabuchi K. Motomura, A. Kouno, T. Ono, A. Miyamoto, N.Takido and N. Inou: Long-term heart substitution with an artificial heart in goats, *asaio J.*, 8(3) 155-165,1985
 19. Fujimasa, K. Imachi, M. Nakajima, K. Mabuchi, S. Tsukagoshim A. Kouno T. Ono, N. Takido, K. Motomura, T. Chinzei, Y. Abe, and K. Atsumi: Pathophysiological study of a total artificial heart goat survived for 344 days, *Progress in Artificial Organs-1985*(Y. Nose Ed.),ISAO Press, Cleveland, 345-353, 1986
 20. Y. Abe, M. Nakajima, Y. Orime, K. Maeda, H. Hata, S. Hosaka, K. Mabuchi T. Chinzei, M. Asano, I. Fujimasa, K. Imachi, A. Kouno, T. Ono, and K. Atsumi: Design of contact end of laser probe for contact irradiation laser angioplasty, *Nd-YAG laser in Medicine and Surgery*(Y. Oguro et al Ed) Professional Postgraduate Service K.K.,329-332, 1986
 21. K. Imachi, I. Fujimasa, K. Mabuchi, T. Chinzei, Y. Abe, K. Maeda, K. Imanishi, A. Kouno, T. Ono, and K. Atsumi: A newly designed jellyfish valve for an artificial heart blood pump, *Trans. Am. Soc. Artif. Intern. Organs*, 34(3), 726-728, 1988
 22. K. Maeda, T. Chinzei, K. Imachi, K. Mabuchi, Y. Abe, T. Yonezawa K. Imanishi, I. Fujimasa, and K. Atsumi:Predictive control by physical activity rate of a total artificial heart during exercise, *Trans Am Soc Artif Inter Organs*, 34(3),480-484, 1988
 23. K. Mabuchi, M. Nakajima, K. Imachi, I. Fujimasa, Y. Abe, T. Chinzei K. Maeda, K. Imanishi, M. Asano, T. Yonezawa, and K. Atsumi: Is atrial natriuretic polypeptide a cause of pathophysiology in total artificial heart animals?, *Trans Am Soc Artif Intern Organs*,34(3),463-465, 1988
 24. Y. Abe, T. Chinzei, I. Fujimasa, K. Imachi, K. Mabuchi, K. Maeda, M. Asano A. Kouno, T. Ono, and K. Atsumi: Development of transcatheter energy transmission system for totally implantable artificial heart, *Artificial Heart 2*(T. Akutsu Ed.),Springer-Verlag, Tokyo, 257-261, 1988
 25. T. Yonezawa, T. Onomura, Y. Abe, K. Mabuchi, T. Chinzei, K. Imachi, and K. Atsumi: Comparative study on excimer,CO2 and Nd-YAG laser for biological tissue cutting, *Laser Optoelectronics in Medicine*(R. Waidlich & W.Waidlich Ed), Springer-Verlag,31-34, 1988
 26. Y. Abe, T. Chinzei, K. Imanishi, T. Yonezawa, S. Niwa, K. Yotsuya, I. Sogawa, T. Uemiya, S. Kanazawa, I. Fujimasa, K. Imachi, M. Suzukawa, K. Mabuchi, M. Asano, Y. Tago, A. Kouno, T. Ono, and K. Atsumi: Laser angioplasty with excimer laser-animal experiment, *SPIE*,1066,115-122, 1989
 27. T. Yonezawa, T. Onomura, R. Kosaka, Y. Miyaji, S. Tanaka, H. Watanabe, Y. Abe, K. Imachi, K. Atsumi, T. Chinzei, K. Mabuchi, and I. Fujimasa: The system and procedures of percutaneous intradiscal laser nucleotomy, *SPINE*, 15(11), 1175-1185(, 1990
 28. K. Imachi, T. Chinzei, Y. Abe, K. Mabuchi, K. Imanishi, T. Yonezawa, A. Suzuki, T. Isoyama, K. Atsumi, and I. Fujimasa: Development of flow-transformed pulsatile total artificial heart for total implantation, *Artificial Organs*, 16(3),308-313, 1992
 29. K. Imachi, K. Mabuchi, T. Chinzei, Y. Abe, K. Imanishi, T. Yonezawa, A. Kouno, T. Ono, H. Nozawa, T. Isoyama, K. Atsumi, and I. Fujimasa: Fabrication of a jellyfish valve for use in an artificial heart, *ASAIO Journal*, 38(3), 237-242, 1992
 30. K. Imachi, T. Chinzei, Y. Abe, T. Isoyama, K. Mabuchi, K. Imanishi, T. Ono, A. Kouno, M. Kusakabe, K. Atsumi and I. Fujimasa: A new apparatus for chronic observation of microcirculation in-situ to evaluate an artificial organ performance. *ASAIO Journal*, 40(3) M757-761, 1994
 31. K. Imachi, Y.Abe, T.Chinzei, K.Mabuchi, K.Imanishi, T.Isoyama, A.Kouno, T.ono and I.Fujimasa: Factors Influencing hemodynamics blood chemical data and hormone secretion of total artificial heart goat. In *Progress in Microcirculation Research*(H. Niimi, M. Oda, T. Sawada, R-J Xiu ed), Pergamon Press, London, 453-458, 1994
 32. Y. Abe, T. Chinzei, K. Imachi, K. Mabuchi, K. Imanishi, T. Isoyama, H. Matsuura, G. Senih, H. Nozawa, A. Kouno, T. Ono, K. Atsumi, and I. Fujimasa: Can total artificial heart (TAH) animals control their TAH by themselves?- One year survival of a TAH goat with a new automatic control method. *ASAIO J*, 40(3) M506-M509, 1994.
 33. T. Isoyama., K. Imachi, Y. Abe, T. Chinzei, K. Imanishi, K. Mabuchi, H. Matuura, I. Fujimasa: New Version of flow transformed pulsatile total artificial heart having no electrical switching valve. *Artificial Organs*, 19(7), 694-696, 1995.
 34. K. Imachi: Implant science of artificial organs: Design for success. *Artificial Organs*, 21(11), 1211-1216, 1997.
 35. R. Kosaka, T. Onomura, T. Yonezawa, Y. Ichimura, and K. Imachi: Percutaneous laser nucleotomy for lumbar disc herniation: Preliminary report of early results and MRI findings, *J Orthop Sci*, 1, 102-112, 1996.
 36. Y. Abe, T. Chinzei, K. Mabuchi, T. Isoyama, K. Baba, H. Matsuura, A. Kouno, T. Ono, S. Mochizuki, Y. Sun, K. Imanishi, K. Atsumi, I. Fujimasa and K. Imachi: Over 500 days' survival of a goat with a total artificial heart with 1 / R control. In *Heart Replacement-Artificial Heart 6*(ed. T. Akutsu, H. Koyanagi), Springer-Verlag, Tokyo, 34-38, 1998.
 37. K. Mabuchi, Y. Abe, S. Shimizu, K. Imachi, T. Chinzei, H. Matsuura, T. Isoyama, K. Baba, K. Imanishi, S. Mochizuki, Y. Sun, T. Tago, A. Kouno, T. Ono, and I. Fujimasa: Pathological study of a goat that survived for 532 days with a total artificial heart

- using the 1 / R control method. In *Heart Replacement-Artificial Heart 6*(ed. T. Akutsu, H. Koyanagi), Springer-Verlag, Tokyo, 313-317, 1998.
38. Y. Abe, T. Chinzei, K. Mabuchi, A. J. Snyder, T. Isoyama, K. Imanishi, T. Yonezawa, H. Matsuura, A. Kouno, T. Ono, K. Atsumi, I. Fujimasa, and K. Imachi: Physiological control of a total artificial heart-Conductance and arterial pressure based control, *J. Appl. Physiol.*, 84(3), 868-876, 1998.
 39. Y. Abe, T. Chinzei, T. Ono, S. Mochizuki, I. Saito, P. Guba, T. Karita, Y. P. Sun, A. Kouno, T. Isoyama, K. Baba, and K. Imachi: Implantation of the undulation pump total artificial heart in the goat, *Artificial Organs*, 23(10), 932-938, 1999.
 40. K. Imachi, T. Chinzei, Y. Abe, T. Isoyama, S. Mochizuki, I. Saito, T. Ono, T. Karita, H. Matsuura, A. Kouno, K. Mabuchi, I. Fuhimasa, and K. Atsumi: Implantable total artificial heart - History and present status at the University of Tokyo, *J. of Artificial Organs*, 2(1): 13-23,
 41. T. Karita, K. Imachi, T. Taguchi, M. Akashi, K. Sato, and J. Tanaka: In vitro calcification model Part -1: Apatite formation on segmented polyurethane containing silicone using an alternate soaking process. *J of Bioactive and Compatible Polymers*, 15, 72-84, 2000
 42. S. Mochizuki, Y. Abe, T. Chinzei, T. Isoyama, T. Ono, I. Saito, P. Guba, T. Karita, Y. P. Sun, A. Kouno, T. Suzuki, K. Baba, K. Mabuchi, and K. Imachi: Results of animal experiments using an undulation pump total artificial heart: Analysis of 10 day and 19 day survival, *ASAIO Journal*, 46(4): 500-504, 2000
 43. K. Imachi, T. Chinzei, Y. Abe, K. Mabuchi, H. Matsuura, T. Karita, K. Iwasaki, S. Mochizuki, Y-P Son, I. Saito, A. Kouno, and T. Ono: A new hypothesis on the mechanism of calcification formed on a blood contacted polymer surface. *J. of Artificial Organs*, 4(1), 74-82, 2001.
 44. Y. Abe, T. Chinzei, T. Isoyama, T. Ono, S. Mochizuki, I. Saito, K. Iwasaki, M. Ishimaru, T. Karita, A. Kouno, K. Baba, and K. Imachi: One month survival with undulation pump total artificial heart in a goat, *Artificial Organs*, 25(1): 69-71, 2001.
 45. Y. Abe, T. Chinzei, T. Isoyama, T. Ono, S. Mochizuki, I. Saito, K. Iwasaki, M. Ishimaru, A. Baba, A. Kouno, T. Karita, K. Baba, and K. Imachi: Progress in the development of the undulation pump total artificial heart, *J. of Congestive Heart Failure and Circulatory Support*, 1(4), 167-170, 2001, and In *Heart Replacement-Artificial Heart 7*(ed. T. Akutsu, H. Koyanagi), ISIS Medical Media Ltd. England, 167-170, 2001.
 46. Saito, Y. Abe, T. Chinzei, T. Ono, T. Isoyama, S. Mochizuki, K. Iwasaki, A. Baba, A. Kouno, T. Karita, M. Ishimaru, A. Baba, and K. Imachi: Miniature undulation pump for the study of renal circulation, *J. of Congestive Heart Failure and Circulatory Support*, 1(4), 321-325, 2001, and In *Heart Replacement-Artificial Heart 7*(ed. T. Akutsu, H. Koyanagi), ISIS Medical Media Ltd. England, 321-325, 2001.
 47. Y. Abe, T. Chinzei, T. Isoyama, T. Ono, T. Ozeki, I. Saito, A. Kouno, and K. Imachi: Principle of the rotary undulation pump, *J Artif Organs*, 5(2), 84-90, 2002.
 48. K. Iwasaki, M. Umezu, K. Iwasaki, Y. Abe, T. Chinzei, T. Isoyama, I. Saito, M. Ishimaru, K. Imachi: The improved jellyfish valve: Durability, enhancement with sufficient blood compatibility, *ASAIO Journal*, 48: 532 - 537, 2002.

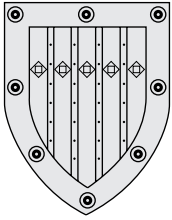

Department of Neuropathology

Outline and Research Objectives

The long-term goal of the research in our department is to determine the molecular events that lead to the development of Alzheimer's disease (AD). For this purpose, we are analyzing two proteins that have been implicated in the AD pathogenesis: amyloid β -protein (A β) and tau.

Faculties and Students

Professor and Chair	Yasuo Ihara, M.D. (1991~)
Lecturer	Maho Morishima, Ph.D.
Associate	Satoru Funamoto, Ph.D. Kozo Motonaga, Ph.D.
Graduate Student.....	7
Secretary	1

Past Research and Major Accomplishments

Identification of posttranslational modifications of tau in paired helical filaments

Tau in paired helical filaments (PHF) is characterized by hyperphosphorylation and ubiquitination. The former causes the tau to migrate slower than dephosphorylated counterparts, and such particular tau makes three distinct bands on the Western blot, and called PHF-tau. We found that this phosphorylation somehow resemble that seen in fetal tau, because many phosphorylation-dependent monoclonal antibodies that react with PHF-tau recognize fetal tau. This indicates that fetal tau is phosphorylated to a greater extent than adult tau. We underwent the work to determine the exact sites for phosphorylation, using selective modification of phosphorylated Ser residues and their identification of amino acid sequencing and mass spec. As a result more than 20 phosphorylation sites in PHF-tau were determined: about half number of the sites were proline-directed, while the remaining were nonproline-directed. By our work the phosphorylation of PHF-tau was fully characterized.

PHF was found to be ubiquitinated in 1987, and since then we attempted to determine the ubiquitination sites in tau, but failed because of purification of ubiquitinated tau was very difficult and provided only very poor yield. From smeared tau (see below) we obtained a small amount of purified ubiquitinated tau, which was digested by lysyl endopeptidase and generated fragments were subjected to mass spec. Thus ubiquitinated sites were accurately determined,

and found in the microtubule-binding domain of tau.

One of the most remarkable characteristics of the tau in PHF is smearing on the blot from high molecular mass region down to 1-2 kD. The extent of smearing is well-correlated with the density of neurofibrillary tangles. We purified smeared tau using HPLC and analyzed protein chemically. Deamidation and isoaspartate formation were found, suggesting that smeared tau represents aging of NFT *in vivo*.

(2) Determination of A β 42 as the predominant species deposited in the brain

At that time, two A β species were known, but their significance was unknown, although in the culture media A β 40 that terminates in Val-40 is the major species. Using end-specific monoclonals that were developed by N. Suzuki, we found immunocytochemically that A β 42 that terminates in Ala-42, a minor species among the secreted A β , is predominant in the parenchyma of AD cortex. To learn about the temporal profile for A β deposition in the human brain, we examined the brains from Down syndrome patients who invariably develop Alzheimer pathologies after the middle ages. In this way we found that the first species deposited in the brain is A β 42.

(3) Quantification of A β accumulation in the human brain

With collaboration with N. Suzuki, we constructed two-site ELISA highly specific for A β 40 or A β 42. We first applied the ELISA for the quantification of A β 40 and A β 42 in the human brain. The biochemical alterations specific to AD may start much earlier than we previously thought. The work on CAA suggests four stages in the evolution: biochemically detectable stage, immunocytochemically detectable stage, histologically (Congo red) detectable stage, and clinically (multiple and recurrent hemorrhage in the aged) detectable stage. In other words, clinically overt patients are just a tip of the iceberg. The similar time course can be applicable to parenchymal A β deposition; biochemical accumulation of A β should start in the 40s (or even before). And AD patients are most

likely to represent a tip of the iceberg. A straightforward interpretation would be that AD is the consequence of the longstanding biochemical abnormalities.

Here, we focus on the nature of the initial biochemical abnormality, eventually leading to β -amyloidogenesis, rather than on why A β accumulate in the brain in an exponential way. In particular, we are currently concerned about possible roles of low-density membrane domain (detergent-insoluble, glycolipid and cholesterol enriched domain; DIGs) in the A β 40 and A β 42 metabolism, and in the earliest stage of β -amyloidogenesis.

As A β accumulates, seemingly, A β 42 shifts to higher density fractions, but A β 40 tends to stay low. Possible explanations include: When a large amount of A β accumulated, the low-density membrane domain may shift to higher density or A β 42-bound low-density membrane domain may lose specific lipid composition (cholesterol and/or sphingolipid), resulting in shift to higher density. In either way, there may be a certain critical level of A β 42 in the domain beyond which the membrane-bound A β 42 cannot float.

(4) Accelerated A β accumulation in ϵ 4-bearing subjects

We attempted to determine when A β deposition starts in most human brains and how it is influenced by *apolipoprotein E* (*apoE*) allele ϵ 4, a strong risk factor for late-onset AD. We successfully quantitated, using an improved extraction protocol and sensitive ELISA, the A β 40 and A β 42 levels in the insoluble fraction of the brains from many nondemented subjects aged 22 to 81 years. Both A β 40 and A β 42 were detectable in the insoluble fraction of the brains even from young subjects aged 20 to 30 years. The incidence of the subjects significantly accumulating A β increased in an age-dependent manner; A β 42 levels arose steeply in some subjects in their late 40s and this was accompanied by a much smaller rise in A β 40 levels. *ApoE* ϵ 4 was found to significantly enhance A β 42 and, to a less extent, A β 40 accumulation. These results strongly suggest that the presence of ϵ 4 allele sets earlier in life the start of A β accumulation in the brain.

(5) Discovery of ϵ -cleavage using a cell-free system

A β is generated from β -amyloid precursor protein (APP) when β -secretase cleavage at the extracellular domain produces a 99-residue C-terminal fragment called CTF99 or CTF β . Subsequent cleavage of CTF β in the middle of the transmembrane domain by γ -secretase primarily produces either a 40-residue protein (A β 40) or a 42-residue protein (A β 42). Intramembrane

γ -secretase cleavage of CTF β should yield a 59- or 57-residue cytoplasmic C-terminal fragment (CTF γ 41-99 or 43-99; APP712-770 or 714-770 according to the numbering of APP770 isoform) called CTF γ . To learn more about the properties of γ -cleavage, we undertook to establish cell-free system for generation of A β and CTF γ , and characterize CTF γ , the other product of this unusual cleavage. The generated CTF γ consists largely of CTF γ 50-99, and of CTF γ 49-99, although the latter is several to ten-fold less than the former. Comparison of the cleavage sites of APP, APLP1, and APLP2 identifies new cleavage site: two to five residues inside the cytoplasmic membrane boundary. Therefore, this intramembrane cleavage is distinct from the A β -generating γ -cleavage that occurs in the middle of the transmembrane domain (more than nine residues inside the membrane boundary).

It has been unclear why APP is cleaved near the middle of the transmembrane domain, whereas Notch 1 is cleaved immediately inside the cytoplasmic membrane boundary. Overall, our findings strongly suggest that the cleavage of Notch corresponds to this distinct type of cleavage rather than to γ -cleavage.

Current Research and Future Prospects

(1) Characterization of the substrate specificity of γ -secretase

1. Is ϵ -cleavage a reality? Can we exclude the possibility that γ -cleavage is followed by swift, step-wise cleavages by a particular amino peptidase? Definite evidence requires demonstration of longer A β (A β 1-49 or 1-50) and/or the middle segment (A β 41-49). Can one detect a longer A β species in the membrane?
2. If it is reality, what is the meaning of γ -cleavage? Does the presence ragged C termini of A β suggest participation of a particular carboxyl peptidase in the generation of A β ?
3. If so, what is the relationship between γ - and ϵ -cleavage? The two cleavages may not be in one to one stoichiometric relationship.
4. The general principle of type 1 membrane protein degradation. shedding, release of ectodomain, followed by intramembrane (ϵ -) cleavage. How is the intramembrane segment left after ϵ -cleavage degraded?
5. Is A β 40 and A β 42 production separable? How is A β 40 or A β 42 generation correlated to CTF γ 49-99 or CTF γ 50-99?

(2) Mechanism of A β accumulation in the brain

1. At present the mechanism of FAD (Familial AD) can be understood by altered enzyme-substrate

relationship: Mutations in enzyme (presenilin) or substrate (APP) causes an (small) increase in the A β 42 production, which eventually leads to AD. Patients with presenilin or APP mutants usually show higher levels of A β 42 in the plasma. Presumably, whether this relationship is altered can be detected by increased levels of A β 42 in the plasma. Another pathway to development of AD is being proposed: increased tendency to protofibril formation.

2. The role of ApoE4 is not to modify the enzyme-substrate relationship, but to mediate through other pathways, thereby leading to earlier build-up of senile plaques. Potential target would be in the exchange of A β between cell membrane and HDL particles, in the transport of A β through BBB or in the A β fibrillization.
3. The thought into exponential accumulation curve may provide us with some insights into the mechanism. The accumulation curve may be simulated by the equation: $A(t) = C(t-40)^n / 1 + (t-40)^n$, where C: constant, t, age > 40; steepness in the accumulation depends on n. This equation represents cooperativity phenomena (phase transition), and may suggest that age-dependent A β accumulation may be one of such examples in the biology. If so, the underlying mechanism can be explained by enhanced A β aggregation force. A point is why the aggregation potential is enhanced. One possibility is a decrease in the degradation potential (decreased protease activity) during aging. However, it is a bit difficult to envision, because it has not so far been known that certain proteases are acutely inactivated during aging. The other possibility is altered environments induced by aging. Altered lipid composition and/or generation of a certain factor to promote A β aggregation. Altogether, accumulation is a consequence of aggregation, and aggregation may be a consequence of an alteration in the environment, but may not be decreased protease activity. In this regard, it may be important to investigate the significance of A β accumulation in the raft. First, to examine whether raft-accumulated A β is younger than extracellularly deposited A β by using pyroGlu-specific antibodies. Other markers for in vivo aging include isomerization and racemization of Asp residues and truncation of the A β molecule.

(3) Tau and neuronal cell death

What do we know about the significance of intracellular tau deposition, and what should we do in the future?

1. NFT itself is not so harmful to cell. NFT-bearing neurons are viable, and still attempt to maintain

dendritic arborization. NFT-bearing oligodendrocytes rather specific for FTDP-intron mutations still supply enough amounts of myelin. No demyelination is detected by a classical method.

2. But often, dendrites of NFT-bearing neurons are compromised, which reminds us of dying-back neuropathy. Presumably, curly fibers represent dying-back segments of basal dendrites isolated from neuronal cell bodies.
3. FTDP-17 is characterized by tauopathy and neuronal loss. P301L mutation is featured by extensive neuronal loss rather than NFT formation (see transgenic fly; Wittmann CW et al. *Science* 2001;293:711-4), while R406W mutation is featured by NFT formation rather than neuronal loss. Clinical course may depend on neuronal loss rather than NFT formation. This is consistent with the old view that the degree of dementia in AD is best correlated with the extent of neuronal loss.
4. Thus, the most important question about tau is why and how tau kills the neuron, rather than why and how it aggregates into NFT.
5. Significance of hyperphosphorylation of tau in PHF or PHF-like fibrils. Hyperphosphorylation of tau may be a consequence of degeneration of neuron, but not a cause of degeneration. Study on R406W brain showed that i) cytosolic R406W tau is less phosphorylated, which is consistent with an observation with CHO stable transfectant; ii) but the mutant tau composing PHF-like fibrils is hyperphosphorylated. A most likely interpretation is as follows. The mutant tau has a bulky residue close to its microtubule-binding domain, and when the mutant tau interact with tubulin or microtubules, a particular kinase cannot access to Ser-396 and 404, resulting in hypophosphorylation on these residues. Once the interaction with tubulin or microtubules is lost (by degeneration), the mutant tau takes a random structure as does wild-type tau, and these residues are freely accessed by kinase and become hyperphosphorylated.
6. To do: establishment of FTDP tau knock-in mice; attempt to increase the tau expression level by removing the neo gene by breeding with CAG Cre mice. Breeding with APP transgenic mice (for example, APP^{sw} mice) may make the pathological phenotype to appear within lifespan, and P301L mice may develop NFT and neuronal loss much earlier than wild-type knock-in mice.
7. More data about tau in the cell biology may provide some keys to understanding of the pathogenesis of FTDP-17. For example, differential role of three-repeat and four-repeat tau should be more highlighted.

8. The data from transgenic fly suggest that expression of even wild-type tau may be somehow harmful to viability of fly (Wittmann CW et al. *Science*. 2001;293:711-4). This can be applied to synuclein also (Feany MB, Bender WW. *Nature* 2000;404:394-8). Presumably, the essential feature of FTDP-17 is neuronal death without overt NFT formation. But in many FTDP-17 cases, both neuronal loss and NFT formation coexist. This means that the initial step to neuronal death may be shared by the pathway to NFT formation. In this respect, recent observations may be significant (Zhukareva V et al. Loss of brain tau defines novel sporadic and familial tauopathies with frontotemporal dementia. *Ann Neurol*. 2001;49:165-75).
9. Currently there is no unifying hypothesis that can explain remarkable heterogeneity of FTDP-17. If it does exist, it must explain i) Why exonic mutation cause neuronal degeneration as well as ii) Why increased levels of four-repeat tau cause neuronal degeneration.

Research Grants

1. Core Research for Evolutional Science and Technology from the Japan Science and Technology Corporation
Year : 1996 ~ 2001
¥483,000,000.-
2. Grant-in-Aid for Scientific Research on Priority Areas, Advanced Brain
Science Project, from the Ministry of Education, Culture, Sports, Science and Technology, Japan
Year : 2000 ~ 2002
¥108,000,000.-
3. Research Grants for Longevity Sciences from the Ministry of Health and Welfare, Japan
Year: 1999 ~ 2001
¥ 6,000,000.-
4. Grant-in-Aid for Scientific Research (C) from the Ministry of Education, Culture, Sports, Science and Technology, Japan
Year: 1999 ~ 2000
¥ 3,700,000.-
5. Research Grants for Longevity Sciences from the Sasakawa Health Science Foundation, Japan
Year: 1999
¥ 2,900,000.-

Select Publications

1. Oyama F, Shimada H, Oyama R, Titani K, Ihara Y: Differential expression of β amyloid protein precursor (APP) and tau mRNA in the aged human brain: Individual variability and correlation between APP-751 and four-repeat tau. *J Neuropathol Exp Neurol* 50: 560-578, 1991

2. Uchida Y, Takio K, Titani K, Ihara Y, Tomonaga M: The growth-inhibitory factor that is deficient in the Alzheimer's disease brain is a 68-amino acid metallothionein-like protein. *Neuron* 7: 337-347, 1991
3. Watanabe N, Takio K, Hasegawa M, Arai T, Titani K, Ihara Y: Tau 2: A probe for a Ser-conformation in the amino terminus of t. *J Neurochem* 58: 960-966, 1992
4. Kanemaru K, Takio K, Miura R, Titani K, Ihara Y: Fetal-type phosphorylation of the tau in paired helical filaments. *J Neurochem* 58: 1667-1675, 1992
5. Iwatsubo T, Hasegawa M, Esaki Y, Ihara Y: Lack of ubiquitin immunoreactivities at both ends of neuropil threads — possible bidirectional growth of neuropil threads —. *Am J Pathol* 140: 277- 282, 1992
6. Hasegawa M, Morishima-Kawashima M, Takio K, Suzuki M, Titani K, Ihara Y: Protein sequence and mass spectrometric analyses of tau in the Alzheimer's disease brain. *J Biol Chem* 267: 17047-17054, 1992
7. Oyama F, Shimoda H, Oyama R, Titani K, Ihara Y: A novel correlation between the levels of β -amyloid protein precursor and tau transcripts in the aged human brain. *J Neurochem* 59: 1117-1125, 1992
8. Tsuji S, Kobayashi H, Uchida Y, Ihara Y, Miyatake T: Molecular cloning of human growth inhibitory factor cDNA and its down-regulation in Alzheimer's disease. *EMBO J* 11:4843-4850, 1992
9. Oyama F, Shimada H, Oyama R, Titani K, Ihara Y: β -Amyloid protein precursor and tau mRNA levels versus β -amyloid plaque and neurofibrillary tangles in the aged human brain. *J Neurochem* 60:1658-1664, 1993
10. Hasegawa M, Watanabe A, Takio K, Suzuki M, Arai T, Titani K, Ihara Y: Characterization of two distinct monoclonal antibodies to paired helical filaments (PHF) — Further evidence for fetal-type phosphorylation of the tau in PHF —. *J Neurochem* 60:2068-2077, 1993
11. Morishima-Kawashima M, Hasegawa M, Takio K, Suzuki M, Titani K, Ihara Y: Ubiquitin is conjugated with amino-terminally processed tau in paired helical filaments. *Neuron* 10:1151-1160, 1993
12. Yoshida H, Ihara Y: t in paired helical filaments is functionally distinct from fetal t. — assembly incompetence of paired helical filament-t —. *J Neurochem* 61:1183-1186, 1993
13. Watanabe A, Hasegawa M, Suzuki M, Takio K, Morishima-Kawashima M, Titani K, Arai T, Kosik KS, Ihara Y: In vivo phosphorylation sites in fetal and adult rat tau. *J Biol Chem* 268:25712-25717, 1993
14. Ueda K, Fukushima H, Masliah E, Xia Y, Iwai A, Yoshimoto M, Otero DAC, Kondo J, Ihara Y, Saitoh T: Molecular cloning of a novel component of amyloid in Alzheimer's disease. *Proc Natl Acad Sci USA* 90:11282-11286, 1993
15. Oyama F, Cairns NJ, Shimada H, Oyama R, Titani K, Ihara Y: Down's syndrome: Upregulation of β -amyloid protein precursor and tau mRNAs and their

- defective coordination. *J Neurochem* 62:1062-1066, 1994
16. Iwatsubo T, Hasegawa M, Ihara Y: Neuronal and glial tau-positive inclusions in diverse neurologic diseases share common phosphorylation characteristics. *Acta Neuropathol* 88:129-136, 1994
 17. Iwatsubo T, Odaka A, Suzuki N, Mizusawa H, Nukina N, Ihara Y: Visualization of A β 42(43) and A β 40 in senile plaques with end-specific A β -monoclonals: Evidence that an initially deposited species is A β 42(43). *Neuron* 13:45-53, 1994
 18. Suzuki N, Iwatsubo T, Odaka A, Ishibashi Y, Kitada C, Ihara Y: High tissue content of soluble β 1-40 is linked to cerebral amyloid angiopathy. *Am J Pathol* 145:452-460, 1994
 19. Oyama F, Oyama R, Ihara Y: Apolipoprotein E Genotype versus Alzheimer's pathologies and related-gene expression in the aged population. *Mol Brain Res* 29:92-98, 1995
 20. Morishima-Kawashima M, Hasegawa M, Takio K, Suzuki M, Titani K, Ihara Y: Proline-directed and non-proline-directed phosphorylation of PHF-tau. *J Biol Chem* 270:823-829, 1995
 21. Iwatsubo T, Mann DMA, Odaka A, Suzuki N, Ihara Y: Amyloid β -protein (A β) deposition: A β 42(43) precedes A β 40 in Down's syndrome. *Ann Neurol* 37:294-299, 1995
 22. Saido TC, Iwatsubo T, Mann DMA, Shimada H, Ihara Y, Kawashima S: Dominant and differential deposition of distinct β -amyloid peptide species, A β N3(pE), in senile plaques. *Neuron* 14:457-466, 1995
 23. Uchida Y, Ihara Y: The N-terminal portion of growth inhibitory factor is sufficient for biological activity. *J Biol Chem* 270: 3365-3369, 1995
 24. Shinkai Y, Yoshimura M, Ito Y, Odaka A, Suzuki N, Yanagisawa K, Ihara Y: Amyloid β -proteins (A β)1-40 and 1-42(43) in the soluble fraction of extra- and intracranial blood vessels. *Ann Neurol* 38:421-428, 1995
 25. Yanagisawa K, Odaka A, Suzuki N, Ihara Y: GM1 ganglioside-bound amyloid β -protein (A β): A possible form of preamyloid in Alzheimer's disease. *Nature Med* 1: 1062-1066, 1995
 26. Iwatsubo T, Yamaguchi H, Fujimuro M, Yokosawa H, Ihara Y, Trojanowski JQ, Lee VM-Y: Purification and characterization of Lewy bodies from the brains of patients with diffuse Lewy body disease. *Am J Pathol* 148:1517-1529, 1996
 27. Gu Y, Oyama F, Ihara Y: τ is widely expressed in rat tissues. *J Neurochem* 67:1235-1244, 1996
 28. Namekata K, Oyama F, Imagawa M, Ihara Y: Human transferrin (Tf) : A single mutation at codon 570 determines the TfC1 or TfC2 variant. *Human Genet* 100: 457-458, 1997
 29. Yamazaki T, Haass C, Saido TC, Omura S, Ihara Y: Specific increase in amyloid β -protein 42 secretion ratio by calpain inhibition. *Biochemistry* 36: 8377-8383, 1997
 30. Hamano T, Yoshimura M, Yamazaki T, Shinkai Y, Yanagisawa K, Kuriyama M, Ihara Y: Amyloid β -protein (A β) accumulation in the leptomeninges during aging and in Alzheimer disease. *J Neuropathol Exp Neurol* 56: 922-932, 1997
 31. Wild-Bode C, Yamazaki T, Capell A, Leimer U, Steiner H, Ihara Y, Haass C: Intracellular generation and accumulation of amyloid β -peptide terminating at amino acid 42. *J Biol Chem* 272: 16085-16088, 1997
 32. Shinkai Y, Yoshimura M, Morishima-Kawashima M, Ito Y, Shimada H, Yanagisawa K, Ihara Y: Amyloid β -protein deposition in the leptomeninges and cerebral cortex. *Ann Neurol* 42: 899-908, 1997
 33. Funato H, Yoshimura M, Yamazaki T, Saido TC, Ito Y, Yokofujita J, Okeda R, Ihara Y: Astrocytes containing amyloid β -protein (A β)-positive granules are associated with A β 40-positive diffuse plaques in the aged human brain. *Am J Pathol* 152: 983-992, 1998
 34. Yoshida H, Watanabe A, Ihara Y: Collapsin response mediator protein (CRMP)-2 is associated with neurofibrillary tangles in Alzheimer's disease. *J Biol Chem* 273: 9761-9768, 1998
 35. Nakabayashi J, Yoshimura M, Morishima-Kawashima M, Ito Y, Funato H, Miyakawa T, Yamazaki T, Ihara Y: Amyloid β -protein (A β) accumulation in the putamen and mammillary body during aging and in Alzheimer's disease. *J Neuropathol Exp Neurol* 57: 343-352, 1998
 36. Oyama F, Sawamura N, Kobayashi K, Morishima-Kawashima M, Kuramochi T, Ito M, Tomita T, Maruyama K, Saido TC, Iwatsubo T, Capell A, Walter J, Grünberg J, Ueyama Y, Haass C, Ihara Y: Mutant presenilin 2 transgenic mouse: Increased A β levels and a marked age-dependent increase in the A β 42 ratio in the brain. *J Neurochem* 71: 313-322, 1998
 37. Funato H, Yoshimura M, Yamazaki T, Saido TC, Ito Y, Yokofujita J, Okeda R, Ihara Y: Quantitation of amyloid beta-protein (A β) in the cortex during aging and in Alzheimer's disease. *Am J Pathol* 152: 1633-1640, 1998
 38. Murakami N, Oyama Y, Gu Y, McLennan IS, Nonaka I, Ihara Y: Accumulation of tau in autophagic vacuoles in chloroquine myopathy. *J Neuropathol Exp Neurol* 57: 664-673, 1998
 39. Morishima-Kawashima M, Ihara Y: The presence of amyloid β -protein in the detergent-insoluble membrane compartment of human neuroblastoma cells. *Biochemistry* 37: 15247-15253, 1998
 40. Enya M, Morishima-Kawashima M, Yoshimura M, Shinkai Y, Kusui K, Khan K, Games D, Schenk D, Sugihara S, Yamaguchi H, Ihara Y: Appearance of sodium dodecyl sulfate-stable amyloid β -protein (A β) dimer in the cortex during aging. *Am J Pathol* 154: 271-279, 1999
 41. Watanabe A, Takio K, Ihara Y: Deamidation and isoaspartate formation in smeared tau in paired helical filaments— unusual properties of the microtubule-binding domain of tau —. *J Biol Chem* 274: 7368-7378, 1999

42. Matsumura N, Yamazaki T, Ihara Y: Stable expression in Chinese hamster ovary cells of mutated tau genes causing frontotemporal dementia and parkinsonism linked to chromosome 17 (FTDP-17). *Am J Pathol* 154: 1649-1656, 1999
43. Funato H, Enya M, Yoshimura M, Morishima-Kawashima M, Ihara Y: The presence of sodium dodecyl sulfate-stable amyloid β -protein dimers in the hippocampus CA1 not exhibiting neurofibrillary tangle formation. *Am J Pathol* 155: 23-28, 1999
44. Misonou H, Morishima-Kawashima M, Ihara Y: Oxidative stress induces intracellular accumulation of amyloid β -protein ($A\beta$) in human neuroblastoma cells. *Biochemistry* 39:6951-6959, 2000
45. Sawamura N, Morishima-Kawashima M, Waki H, Kobayashi K, Kuramochi T, Ito M, Oyama F, Ando S, Ihara Y: Mutant-presenilin 2-transgenic mice: A large increase in the levels of $A\beta$ 42 is presumably associated with the low-density membrane domain that contains decreased levels of glycerophospholipids and sphingomyelin. *J Biol Chem* 275:27901-27908, 2000
46. Morishima-Kawashima M, Oshima N, Ogata H, Yamaguchi H, Yoshimura M, Sugihara S, Ihara Y: Effect of apolipoprotein E allele ϵ 4 on the initial phase of amyloid β -protein accumulation in the human brain. *Am J Pathol* 157: 2093-2099, 2000
47. Oshima N, Morishima-Kawashima M, Yamaguchi H, Yoshimura M, Sugihara S, Khan K, Games D, Schenk D, Ihara Y: Accumulation of amyloid beta-protein in the low-density membrane domain accurately reflects the extent of beta-amyloid deposition in the brain. *Am J Pathol* 158: 2209-2218, 2001
48. Miyasaka T, Morishima-Kawashima M, Ravid R, Heutink P, van Swieten JC, Nagashima K, Ihara Y: Molecular analysis of mutant and wild-type tau deposited in the brain affected by FTDP-17 R406W mutation. *Am J Pathol* 158: 373-379, 2001
49. Yamazaki T, Chang TY, Haass C, Ihara Y: Accumulation and aggregation of amyloid β -protein in late endosomes of Niemann-Pick Type C cells. *J Biol Chem* 276: 4454-4460, 2001
50. Gu Y, Misonou H, Sato T, Dohmae N, Takio K, Ihara Y: Distinct intramembrane cleavage of the β -amyloid precursor protein family resembling γ -secretase-like cleavage of Notch. *J Biol Chem* 276:35235-35238, 2001

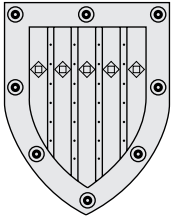

Department of Cognitive Neuroscience

Outline and Research Objectives

The Department of Cognitive Neuroscience is one of the three departments composing the Speech and Cognitive Science Section. Since the establishment of this department in 1991, we have been working in the field of brain and cognition, especially from the point of view of language.

Main research topics:

1. Research on the brain damaged patient: callosal syndrome, right temporal lobe syndrome, macular sparing, aphasia therapy
2. Functional magnetic resonance imaging (fMRI) during cognitive process: mental writing, writing, face recognition, reading comprehension, naming, reading aloud
3. Magnetoencephalographic (MEG) study of cognitive function: early component of the visual evoked magnetic field, motor imagery
4. Brain mechanism of Japanese kanji processing

Teaching activities:

1. Graduate course: Speech science and language communication, Pathophysiology of speech and language Communication, Introduction to neuroscience
2. Master course: Cognitive neuroscience
3. Graduate course, Faculty of Literature: Experimental phonetics
4. Undergraduate course: Speech and language communication, Medical data processing
5. Undergraduate course, Faculty of Education: Fundamentals of speech science

Clinical activities:

The assessments and therapies for aphasia, apraxia, agnosia, amnesia and dementia are conducted in collaboration with the Deptment of Neurology, Department of Neurosurgery and Department of Otorhinolaryngology

Faculties and Students

Professor	Morihiro Sugishita Dr. Health Sci., Dr. Medical Sci. 1993~
Associate	2
Graduate Students	2.
Research Students.....	1
Guest Researchers.....	2

Past Research and Major Accomplishments

1. Research on the Brain Damaged Patient

1-1) *Sugishita M, et al. Dichotic listening in patients with partial section of the corpus callosum. Brain 118, 417-427, 1995:* Despite the common assumption that damage to the posterior part of the trunk of the corpus callosum causes strong left-ear suppression, the results indicated that damage to the splenium causes strong left-ear suppression.

1-2) *Koike A, et al. Preserved musical abilities following right temporal lobectomy. Journal of Neurosurgery 85, 1000-1004, 1996:* No disturbances in the Seashore Measures were detected after temporal lobectomy on either side.

1-3) *Sugishita M, et al. Hemispheric representation of the central retina of commissurotomy subjects. Neuropsychologia 32, 399-415, 1994:* The region of the right (temporal) hemiretina represented by both hemispheres in letter processing, if it exists, was estimated as less than 0.6° from the foveal center.

2. Functional Magnetic Resonance Imaging (fMRI) During Cognitive Process

2-1) *Sugishita M, et al. Functional magnetic resonance imaging (fMRI) during mental writing with phonograms. NeuroReport 7, 1917-1921, 1996:* Four regions were activated during mental writing in all six subjects; the left intraparietal sulcus, the middle part of the left precentral sulcus and the posterior part of

the left superior frontal sulcus, the right intraparietal sulcus, and either or both of the left and right cingulate sulci. The left intraparietal region was usually the most extensively activated.

2-2) Katanoda K, et al. *A functional MRI study on the neural substrates for writing. Human Brain Mapping 13, 34-42, 2001*: During writing, activations were observed in the anterior part of the left superior parietal lobule, the posterior part of the left middle and superior frontal gyri, and the right cerebellum.

2-3) Katanoda K, et al. *Neural substrates for the recognition of newly learned faces: a functional MRI study. Neuropsychologia 38, 1616-1625, 2000*: The bilateral fusiform gyrus is involved, not only in face perception, but in a certain aspect of face recognition memory, and this aspect is related to the actual recognition of previously viewed faces rather than the processing of novel ones. The right parietal and frontal regions, in contrast, are differentially more associated with the detection of novel faces or retrieval effort.

3. Magnetoencephalographic (MEG) Study of Cognitive Function

3-1) Yoneda K, et al. *The early component of the visual evoked magnetic field. NeuroReport 6, 797-800, 1995*: The early component was observed in three of the nine subjects. The latency ranged from 40 to 45 ms in MEG and from 39 to 47 ms in EEG. The result of dipole localization analysis showed that its origin was cortical, and specifically, the striate cortex.

3-2) Ogiso T, et al. *The precuneus in motor imagery: a magnetoencephalographic study. NeuroReport 11, 1345-1349, 2000*: MEG was applied to subjects who imagined themselves hurdling in self-centered space. In three of six subjects all 300 trials in the motor imagery condition revealed the precuneus dipole. When we divided the 300 trials into four overlapping blocks, all six subjects showed precuneus activity.

4. Brain Mechanism of Japanese Kanji Processing

4-1) Sugishita M, Omura K. *Learning Chinese characters may improve visual recall. Perceptual and Motor Skills 93, 579-594, 2001*: From elementary through high school, Japanese children are required to memorize a large number of distinct visual forms, i.e., roughly 2,000 Chinese characters, and tremendous effort is expended in learning to read and write them. We hypothesized that early training in memorizing Chinese characters and the use of these characters in daily life shapes brain development and facilitates recall of visual forms in general. We administered the Wechsler Memory Scale-Revised (WMS-R) to a repre-

sentative sample of the normal Japanese population (316 persons, 100% Japanese) and compared their scores with data previously obtained from a representative sample of the normal U.S. population (316 persons, 82.5% Caucasian). Compared to the Americans, the Japanese group obtained significantly higher scores on these two visual recall subtests in all six age groups (16 to 74 years old).

Current Research

Research on the brain damaged patients: callosal syndrome, right temporal lobe syndrome, macular sparing, aphasia therapy

1. fMRI during cognitive process: mental writing, writing, face recognition, reading comprehension, naming, reading aloud
2. fMRI study on speech dominance in split-brain patients
3. MEG study of cognitive function: visual evoked magnetic fields, motor imagery
4. Brain mechanism of Japanese kanji processing

Future Prospect

1. Cerebral localization of neuropsychological deficits (aphasia, apraxia, agnosia and amnesia): The sites of lesions responsible for neuropsychological deficits will be more precisely localized with the MRI findings of the patient.
2. Brain functional imaging: Functional MRI study will be advanced with development of imaging techniques such as arterial spin labeling other than BOLD techniques and with refinement of experimental paradigm.

Research Grants

1. JSPS Research for the Future Program (Higher Brain Functions) [FY1997~FY 2001] (\$1,095,000/ ¥131,000,000) "Neuroimaging contributions to the understanding of brain language mechanism"
2. JSPS Scientific Research (B) [FY1997~FY 1998] (\$79,170/ ¥9,500,000) "Neuroimaging contributions to the understanding music"
3. JSPS Exploratory Research [FY1997] (\$11,700/ ¥1,400,000) "Study on brain mechanism of spoken word discrimination by MEG"
4. MEXT COE Research (Neuroscience of Music) [FY1997-2001] (\$0/ ¥0) "Paradigm creation in behavioral neurology"
5. MEXT Scientific Research in Priority Areas (Mind Development) [FY1994-1998] (\$100,000/ ¥12,000,000) "Research on disorders of cognitive development by functional MRI"

Select Publications

1. Takayama Y, Sugishita M, Akiguchi I, Kimura J. Isolated acalculia due to left parietal lesion. *Archives of Neurology*, 51, 286-291, 1994
2. Ishiai S, Sugishita M, Watabiki S, Nakayama T, Kotera M, Gono S. Improvement of left unilateral spatial neglect in a line extension task. *Neurology* 44, 294- 298, 1994
3. Sugishita M, Hamilton CR, Sakuma I, Henmi I. Hemispheric representation of the central retina of commissurotomized subjects. *Neuropsychologia* 32, 399-415, 1994
4. Takayama Y, Sugishita M, Kido T, Ogawa M, Fukuyama H, Akiguchi I. Impaired stereoacuity due to a lesion in the left pulvinar. *Journal of Neurology Neurosurgery and Psychiatry* 57, 652-654, 1994
5. Takayama Y, Kido T, Sugishita M, Ogawa M, Akiguchi I. A case of foreign accent syndrome without aphasia caused by a lesion of the left precentral gyrus. *Neurology* 44, 990, 1994
6. Takayama Y, Sugishita M. Astereopsis induced by repetitive magnetic stimulation of occipital cortex. *Journal of Neurology* 241, 522-525, 1994
7. Takayama Y, Sugishita M, Hirose S, Akiguchi I. Anosodiaphoria for dressing apraxia: contributory factor to dressing apraxia. *Clinical Neurology and Neurosurgery* 96, 254-256, 1994
8. Yoneda K, Sekimoto S, Yumoto M, Sugishita M. The early component of the visual evoked magnetic field. *Neuroreport* 6, 797-800, 1995
9. Sugishita M, Otomo K, Yamazaki K, Shimizu H, Yoshioka M, Shinohara A. Dichotic listening in patients with partial section of the corpus callosum. *Brain* 118, 417-427, 1995
10. Seki K, Yajima M, Sugishita M. The efficacy of kinesthetic reading treatment for pure alexia. *Neuropsychologia*, 33, 595-609, 1995
11. Sodeyama N, Tamaki M, Sugishita M. Persistent pure verbal amnesia and transient aphasia after left thalamic infarction. *Journal of Neurology* 242, 289-294, 1995
12. Takeda K, Sugishita M. Word length error types in Japanese left-sided neglect dyslexia. *Clinical Neurology and Neurosurgery* 97, 125-130, 1995
13. Nishiyama K, Momose T, Sugishita M, Sakuta M. Positron emission tomography of reversible intellectual impairment induced by long-term anticholinergic therapy. *Journal of the Neurological Sciences*, 132, 89-92, 1995
14. Takayama Y, Sugishita M, Fukuyama H, Akiguchi I. Localization in spatial vision. *Clinical Neurology and Neurosurgery* 97, 249-252, 1995
15. Endo K, Makishita H, Yanagisawa N, Sugishita M. Modality specific naming and gesture disturbances. A case with optic aphasia, bilateral tactile aphasia, optic apraxia and tactile apraxia. *Cortex* 32, 3-28, 1996
16. Sugishita M, Takayama Y, Shiono T, Yoshikawa K, Takahashi Y. Functional magnetic resonance imaging (fMRI) during mental writing with phonograms. *Neuroreport* 7, 1917-1921, 1996
17. Koike A, Simizu H, Suzuki I, Ishijima B, Sugishita M. Preserved musical abilities following right temporal lobectomy. *Journal of Neurosurgery* 85, 1000-1004, 1996
18. Nishiyama K., Sugishita M, Kurisaki H, Sakuta M. Reversible memory disturbance and intelligence impairment induced by long-term anticholinergic therapy. *Internal Medicine* 37, 514-518, 1998
19. Matsuda O, Saito M, Sugishita M. Cognitive deficits of mild dementia: a comparison between dementia of the Alzheimer's type and vascular dementia. *Psychiatry & Clinical Neurosciences* 52, 87-91, 1998
20. Kobayashi M, Takayama H, Mihara B, Sugishita M. Partial seizure with aphasic speech arrest caused by watching a popular animated TV program. *Epilepsia* 40, 652-654, 1999
21. Tanaka S, Kanzaki R, Yoshibayashi M, Kamiya T, Sugishita M. Dichotic listening in patients with situs inversus: brain asymmetry and situs asymmetry. *Neuropsychologia* 37, 869-874, 1999
22. Ogiso T, Kobayashi K, Sugishita M. The precuneus in motor imagery: a magnetoencephalographic study. *NeuroReport* 11, 1345-1349, 2000
23. Takayama H, Kobayashi M, Sugishita M, Mihara B. Diffusion-weighted imaging demonstrates transient cytotoxic edema involving the corpus callosum in a patient with diffuse brain injury. *Clinical Neurology and Neurosurgery* 102, 135-139, 2000
24. Katanoda K, Yoshikawa K, Sugishita M. Neural substrates for the recognition of newly learned faces: a functional MRI study. *Neuropsychologia* 38, 1616-1625, 2000
25. Katanoda K, Yoshikawa K, Sugishita M. A functional MRI study on the neural substrates for writing. *Human Brain Mapping* 13, 34-42, 2001
26. Sugishita M, Koike A, Shimizu H, Suzuki I, Ishijima B: Right temporal lobe function. *Journal of Neurosurgery* 95, 372, 2001
27. Sugishita M, Omura K. Learning Chinese characters may improve visual recall. *Perceptual and Motor Skills* 93, 579-594, 2001
28. Katanoda K, Matsuda Y, Sugishita M. A spatio-temporal regression model for the analysis of functional MRI data. *NeuroImage* 16, in press, 2002

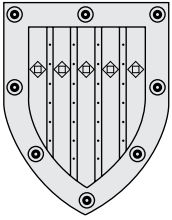

Department of Neuropsychiatry

Outline and Research Objectives

This department of neuropsychiatry has the longest history among all that of Universities in Japan since 1886. In the past quarter century, unfortunately it had been in a unusual condition that two groups, "The Ward" and "The Clinic", had made independent clinical activities in this department and excluded each other. "The Ward" group was influenced by the movement "Anti-Psychiatry" in 1960. During this period the most part of budgets and personnel changes had been frozen. This unfortunate incident made the facilities of the ward and all laboratories of our department old-fashioned and obsolescent. In 1994, two groups had arrived a compromise with each other and started the care of patients in the psychiatric ward and clinic together, however more several years were needed for the regeneration of the department. Now it has already been "normalized", overwhelming the long and difficult period of past quarter century and we have regenerated the productive activities of neuropsychiatry.

Approximately 240 patients with various psychiatric disorders were admitted on last year (2001). Since 2002, new wards was established (34 beds in the secluded ward and 19 beds in the general ward) and this department became to be expected the more active roles on clinical fields in this year. Occupational therapy, art therapy and group therapy are performed in the ward. For the outpatients, we have two "Day Hospital Units" in this department; Day Hospital for young patients with psychotic feature based on cognitive behavioral approach and Day Care for autistic children using educational treatment models.

Research activities in this department are wide-ranged from social psychiatry to molecular biology. Main research activities in this department is as follows, 1) molecular biological studies of psychiatric disorders, 2) neuroscientific studies of stress, 3) psychopathological studies of early schizophrenia, 4) psychophysiological and neuropsychological studies of schizophrenia and epileptic psychosis, 5) community-based psychosocial treatment of chronic schizophrenia, 6) cognitive-developmental or pharmacological treatment of autism and Tourette syndrome, 7) neuroimaging studies of psychiatric disorders, and 8) neuropathological studies of dementias. Starting 2000, a nation-wide Project with the Grant of Japan Science and Technology Agency has organized under the management of this Department, entitled "Molecular mechanisms underlying stress-induced brain dysfunctions and development of diagnosis/treatment strategies on post-traumatic stress disorders (PTSD)".

Faculties and Students

Professor and Chair	Nobumasa Kato, M.D. (1998~)
Associate Professor	Nobuo Nakayasu, M.D. Akira Iwanami, M.D.
Lecturer	Koichi Tsunashima, M.D. Hitoshi Tsuda, M.D. Rinmei Fukuda, M.D.
Associate	10
Graduate Student.....	13
Secretary	4

Past Research and Major Accomplishments

Research activity in our department ranges over diverse fields in neuropsychiatry including biological

and social psychiatry. Professor Kato has been conducting and supervising the researches on the effect of stress on brain using animal models. Especially, various stress-induced changes in hippocampus have been elucidated. Dr Nakayasu had conducted intensive psychopathological research on early symptoms of schizophrenia and proposed the notion of "incipient schizophrenia" in 1990, which could be fundamentally different from its full-blown counterpart. At this early stage, he suggested that we could employ a combination of specific pharmacotherapy and psychotherapy to prevent the outbreak of this devastating illness. Dr Iwanami has been utilizing event-related potentials (ERPs) to investigate the neural correlates of cognitive dysfunction in schizophrenia, methamphetamine psychosis and other mental disorder.

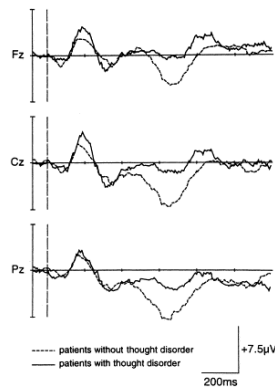

Grand mean ERP waveforms in patients with and without thought disorder. (Iwanami et al. Schizophrenia Research, 2000)

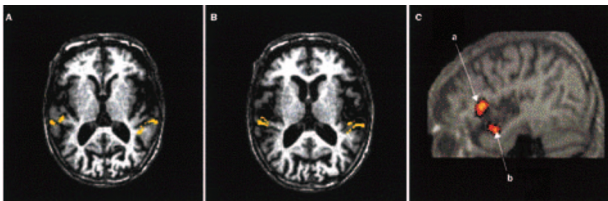

Spatiotemporal excitation patterns of N100m sources and SPECT imaging during musical hallucinations. (Kasai et al. Lancet, 1999)

ders. He found that specific parameters of ERPs correlates the severity of the illness. In the field of social psychiatry, our department was the first to introduce Day Hospital unit in 1980s and made extensive research on the efficacy of this treatment strategy. Our efforts had significantly contributed to the following nationwide introduction of this treatment approach in Japan.

Current Research

The primary activity in our department is the government-supported study in the pathogenesis of stress-induced neuropsychiatric disorders, mainly, post-traumatic stress disorder (PTSD). The development of novel treatment strategy will also be expected. As one of the patient population, victims of the Tokyo subway sarin attack in 1995 kindly served themselves. Especially, we employ multimodal neuroimaging techniques (electroencephalography, event-related potentials, magnetoencephalography, structural magnetic resonance imaging, functional magnetic resonance imaging, magnetic resonance spectroscopy and near infrared spectroscopy) to elucidate the individual vulnerability to this condition and the neurobiological aftereffects of psychological trauma. Other research activities include 1) molecular genetics of psychiatric disorders, 2) basic neuroscience, 3) clinical and basic psychopharmacology, 4) the development of psychosocial treatment approach in autism, and 5) neuropathological studies of dementias.

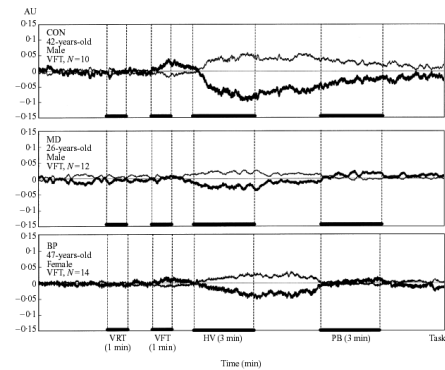

Typical time courses of the NIRS variables during cognitive and physiological tasks. (Matsuo et al. Psychological Medicine, 2002)

Future Prospects

The Last ten years were “The Decade of Brain”. Outstanding progress has been achieved in neuroscience in terms of scientific knowledge and technical innovation. In addition, the human genome project is almost done. Now we are jumping into the 21st century, “The Century of Mind”. Psychological terms should be translated into those of brain, which would provide the more solid basis for psychiatry as a branch of neuroscience. In this context, our basic and clinical research projects are in progress. For holistic understanding of patients suffering psychiatric disorders and their treatments, multi-disciplinary studies should be necessary under the collaboration with other neuroscience research groups.

As a university hospital, clinical practice is also important. We should be always keen to the needs of the public. To meet them, we opened several specialized outpatient clinics, such as PTSD or Child and Adolescent clinic, in addition to regular services. The teams for psychiatric emergency and palliative medicine are also being formed. In addition to clinical services, the public would expect the scientific outputs obtained through clinical studies. The system recruiting subjects or volunteers should be established immediately.

The curriculum for medical students and the training system for residents are now changing. Especially, the “super-rotation” system will begin in a few years. Our training system should be modified for residents to acquire the better clinical clerkship.

We will continue to make our best efforts to fulfill the three major missions of the university hospital, that is, research, clinical service and education.

Research Grants

- 1999:Health Science Research Grants (Research on Brain Science) ¥18,000,000

2. 2000: Target Oriented Brain Science Promotion Program supported by the MEXT 2000-2002 ¥194,493,000
3. 2001: Japan-US Cooperative Reserch Project "Cooperative Brain Reserch 2001-2002 ¥2,700,000
4. 2002: Health Science Research Grants (Research on Health Service) ¥36,000,000

Select Publications

Basic

1. Jinde S, Matsui A, Morinobu A, Takahashi Y, Tsunashima K, Noda A, Yamada N, and Kato N. Elevated neuropeptide Y and corticotropine-releasing factor in the brain of a novel epileptic mutant rat: Noda epileptic rat. *Brain Research* 833, 286-290, 1999.
2. Shirayama Y, Hashimoto K, Matsuki H, Tsunashima K, Iyo M, Higuchi T, and Minabe Y. Increased expression of zif268 mRNA in rat retrosplenial cortex following administration of phencyclidine. *Brain Research* 839, 180-185, 1999.
3. Nagaki S, Fukumachi F, Sakamoto Y, Higuchi H, Miki N, Ono M, Sadamatsu M, Kato N, and Osawa M. Upregulation of brain somatostatin and neuropeptide Y following lidocaine-induced kindling in the rat. *Brain Research* 852, 470-474, 2000.
4. Kohda K, Wang Y, and Yuzaki M. Mutation of glutamate receptor motif reveals its role in gating and d2 receptor channel properties. *Nature Neuroscience* 3, 315-322, 2000.
5. Nishiyama M, Hong K, Mikoshiba K, Poo M-m, and Kato K. Polarity and input specificity of synaptic modification: critical role of Ca²⁺ release from internal stores (underlined authors equally contributed). *Nature* 408, 584-588, 2000.
6. Watanabe K, Ashby CR Jr, Katsumori H, and Minabe Y. The effect of the acute administration of various selective 5-HT receptor antagonists on focal hippocampal seizures in freely-moving rats. *European Journal of Pharmacology* 398, 239-246, 2000.
7. Yasuda S, Ishida N, Higashiyama A, Morinobu S, and Kato N. Characterization of audiogenic-like seizures in naïve rats evoked by activation of AMPA and NMDA receptors in the inferior colliculus. *Experimental Neurology* 164, 396-406, 2000.
8. Minabe Y, Hashimoto K, Watanabe K, and Ashby CR Jr. Acute and repeated administration of the selective 5-HT(2A) receptor antagonist M100907 significantly alters the activity of midbrain dopamine neurons: an in vivo electrophysiological study. *Synapse* 40, 102-112, 2001.
9. Imai H, Nishimura T, Sadamatsu M, Liu Y, Kabuto M, and Kato N. Type II glucocorticoid receptors are involved in neuronal death and astrocyte activation induced by trimethyltin in the rat hippocampus. *Experimental Neurology* 171, 22-28, 2001.

10. Nishimura T, Schwarzer C, Furtinger S, Imai H, Kato N, and Sperk G. Changes in the GABAergic system induced by trimethyltin application in the rat. *Molecular Brain Research* 97, 1-6, 2001.
11. Takahashi J, Tanaka K, Morinobu S, Fujimaki K, Li ST, Kato K, Ohkawa M, Yamawaki S, and Kato N. Influence of restraint stress on the expression and the serine/threonine phosphatase activity of calcineurin in the rat brain. *Synapse* 40, 130-6, 2001.
12. Tsutsumi S, Akaike M, Arimitsu H, Imai H, Kato N. Circulating corticosterone alters the rate of neuropathological and behavioral changes induced by trimethyltin in rats. *Experimental Neurology* 73, 86-94, 2002.

Clinical (genetics)

13. Kato T, Honda M, Kuwata S, Juji T, Kunugi H, Nanko S, Fukuda M, and Honda Y. A novel polymorphism in the promoter region of the tumor necrosis factor alpha gene: No association with narcolepsy. *American Journal of Medical Genetics* 88, 301-304, 1999.
14. Kunugi H, Hattori M, Nanko S, Fujii K, and Kato T. Dinucleotide repeat polymorphism in the neurotrophin-3 gene and hippocampal volume in psychoses. *Schizophrenia Research* 37, 271-273, 1999.
15. Kunugi H, Ishida S, Kato T, Sakai T, Tatsumi M, Hirose T, and Nanko S. No evidence for an association of polymorphism of the tryptophan hydroxylase gene with affective disorders or attempted suicide among Japanese patients. *American Journal of Psychiatry* 156, 774-776, 1999.
16. Kunugi H, Ishida S, Kato T, Tatsumi M, Sakai T, Hattori M, Hirose T, and Nanko S. A functional polymorphism in the promoter region of monoamine oxidase-A gene and mood disorders. *Mol Psychiatry* 4, 393-395, 1999.
17. Sadamatsu M, Masui A, Sakai T, Kunugi H, Nanko S, and Kato N. Familial paroxysmal kinesigenic choreoathetosis: an electrophysiologic and genotypic analysis. *Epilepsia* 40, 942-949, 1999.
18. Kato T, Kunugi H, Nanko S, and Kato N. Association of bipolar disorder with the 5178 polymorphism in mitochondrial DNA. *American Journal of Medical Genetics* 96, 182-186, 2000.
19. Narita K, Sasaki T, Akaho R, Okazaki Y, Kusumi I, Kato T, Hashimoto O, Fukuda R, Koyama T, Matsuo K, Okabe Y, Nanko S, Hohjoh H, and Tokunaga K. Human leukocyte antigen and season of birth in Japanese patients with schizophrenia. *American Journal of Psychiatry* 157, 1173-1175, 2000.
20. Tomita H, Nagamitsu S, Wakui K, Fukushima Y, Yamada K, Sadamatsu M, Masui A, Konishi T, Matsushita Y, Aihara M, Shimizu K, Hashimoto K, Mineta M, Matsushima M, Tsujita T, Saito M, Tanaka H, Tsuji S, Takagi T, Nakamura Y, Nakano S, Kato N, Nakane Y, and Niikawa N. Paroxysmal kinesigenic choreoathetosis locus map to chromosome 16p11.2-q12.1. *American Journal of Human Genetics* 65, 1688-1697, 2000.

21. Kato T, Kunugi H, Nanko S, and Kato N. Mitochondrial DNA polymorphisms in bipolar disorder. *Journal of Affective Disorders* 62, 151-164, 2001.
22. Tatsumi M, Sasaki T, Iwanami A, Kosuga A, Tanabe Y, Kamijima K. Season of birth in Japanese patients with schizophrenia. *Schizophrenia Research* 54, 213-8, 2002.

Clinical (pharmacology/neurobiology)

23. Fukuda R, Sasaki T, Kunugi H, and Nanko S. No changes in paired viral antibody titers during the course of acute schizophrenia. *Neuropsychobiology* 40, 57-62, 1999.
24. Kato T and Kato N. Mitochondrial dysfunction in bipolar disorder. *Bipolar Disorder* 2, 180-190, 2000.
25. Fukuda R. Factors affecting serum haloperidol level assessed by longitudinal therapeutic monitoring. *Progress in Neuropsychopharmacology and Biological Psychiatry* 24, 1299-1318, 2000.
26. Morita S, Shimoda K, Someya T, Yoshimura Y, Kamijima K, and Kato N. Steady-state plasma levels of nortriptyline and its hydroxylated metabolites in Japanese: the impact of CYP2D6 genotype on the hydroxylation of nortriptyline. *Journal of Clinical Psychopharmacology* 20, 141-149, 2000.
27. Iwanami A, Okajima Y, Isono H, Shinoda J, Kasai K, Hata A, Fukuda M, Nakagome K, Kamijima K. Effects of risperidone on event-related potentials in schizophrenic patients. *Pharmacopsychiatry* 34, 73-79, 2001
28. Fujimaki K, Morinobu S, Takahashi J, Yamawaki S, Kato N, Kanno M, Okuyama N, Kawakatsu S, Otani K, Kusumi I, and Koyama T. Nucleotide sequence analysis of the binding site on the inositol 1,4,5-trisphosphate type-1 receptor in bipolar disorder-negative study. *Journal of Affective Disorders* 65, 139-143, 2001.

Clinical (neuroimaging)

Magnetic resonance spectroscopy

29. Hamakawa H, Kato T, Shioiri T, Inubushi T, and Kato N. Quantitative proton magnetic resonance spectroscopy in the bilateral frontal lobes of patients with bipolar disorder. *Psychological Medicine* 29, 639-644, 1999.
30. Murashita J, Kato T, Shioiri T, Inubushi T, and Kato N. Age-dependent alteration of metabolic response to photic stimulation in the human brain measured by ³¹P MR-spectroscopy. *Brain Research* 818, 72-76, 1999.
31. Kato T, Inubushi T, and Kato N. Prediction of lithium response by ³¹P-MRS in bipolar disorder. *International Journal of Neuropsychopharmacology* 3, 83-85, 2000.
32. Murashita J, Kato T, Shioiri T, Inubushi T, and Kato N. Altered brain energy metabolism in lithium-resistant bipolar disorder detected by photic stimulated ³¹P-MR spectroscopy. *Psychological Medicine* 30, 107-115, 2000.

Near-infrared spectroscopy (NIRS)

33. Matsuo K, Kato T, Fukuda M, and Kato N. Alteration of hemoglobin oxygenation in the frontal region in elderly depressed patients measured by near-infrared spectroscopy. *Journal of Neuropsychiatry and Clinical Neuroscience* 12, 465-471, 2000.
34. Matsuo K, Kato N, and Kato T. Decreased cerebral haemodynamic response to cognitive and physiological tasks in mood disorders as shown by near-infrared spectroscopy. *Psychological Medicine* 32, 1029-37, 2002.

Magnetic resonance imaging (MRI)

35. Kasai K, Shenton ME, Salisbury DF, Hirayasu Y, Lee CU, Ciszewski A, Yurgelun-Todd D, Kikinis R, Jolesz FA, McCarley RW. Progressive decrease of left superior temporal gyrus gray matter volume in first-episode schizophrenia. *American Journal of Psychiatry*, in press.
36. Gilbertson MW, Shenton ME, Ciszewski A, Kasai K, Lasko NB, Orr SP, Pitman RK. Smaller hippocampal volume predicts pathologic vulnerability to psychological trauma. *Nature Neuroscience*, in press.
37. Onitsuka T, Shenton ME, Kasai K, Nestor PG, Toner SK, Kikinis R, Jolesz FA, McCarley RW. Fusiform gyrus volume reduction and facial recognition in chronic schizophrenia. *Archives of General Psychiatry*, in press.
38. Kubicki M, Shenton ME, Salisbury DF, Hirayasu Y, Kasai K, Kikinis R, Jolesz FA, McCarley RW: Voxel-based morphometric analysis of gray matter in first-episode schizophrenia. *Neuroimage*, in press.
39. Anderson JE, Wible CG, McCarley RW, Jakab M, Kasai K, Shenton ME: An MRI study of temporal lobe abnormalities and negative symptoms in chronic schizophrenia. *Schizophrenia Research*, in press.
40. Lee CU, Shenton ME, Salisbury DF, Kasai K, Onitsuka T, Dickey CC, Yurgelun-Todd D, Kikinis R, Jolesz FA, McCarley RW: Fusiform gyrus volume reduction in first-episode schizophrenia: an MRI study. *Archives of General Psychiatry* 59, 775-781, 2002.

Clinical (neurophysiology)

41. Kasai K, Yamada H, Kamio S, Nakagome K, Iwanami A, Fukuda M, Yumoto M, Itoh K, Koshida I, Abe O, Kato N. Neuromagnetic correlates of impaired automatic categorical perception of speech sounds in schizophrenia. *Schizophrenia Research* 2002, in press.
42. Kasai K, Asada T, Yumoto M, Takeya J, Matsuda H: Evidence for functional abnormality in the right auditory cortex during musical hallucinations. *Lancet* 354: 1703-1704, 1999.
43. Kasai K, Okazawa K, Nakagome K, Hiramatsu K, Hata A, Fukuda M, Honda M, Miyauchi M, Matsushita M: Mismatch negativity and N2b attenuation as an indicator for dysfunction of the preattentive and controlled processing for deviance detection

- in schizophrenia: a topographic event-related potential study. *Schizophrenia Research* 35: 141-156, 1999.
44. Iwanami A, Okajima Y, Kuwakado D, Isono H, Kasai K, Hata A, Nakagome K, Fukuda M, Kamijima K. Event-related potentials and thought disorder in schizophrenia. *Schizophrenia Research* 42, 187-191, 2000.
 45. Kasai K, Nakagome K, Iwanami A, Fukuda M. Neuropsychiatry and the auditory selective attention. *Current Opinion in Psychiatry* 14, 219-225, 2001.
 46. Kamio S, Nakagome K, Murakami T, Kasai K, Iwanami A, Hiramatsu K-I, Hata A, Watanabe A, Fukuda M, Honda M, Kato N. Impaired suppression of processing in schizophrenic patients suggested by ERPs obtained in a selective attention task. *Schizophrenia Research* 49, 213-221, 2001.
 47. Kasai K, Nakagome K, Itoh K, Koshida I, Hata A, Iwanami A, Fukuda M, Kato N. Impaired cortical network for preattentive detection of change in speech sounds in schizophrenia: a high-resolution event-related potential study. *American Journal of Psychiatry* 159, 546-553, 2002.
 48. Kasai K, Nakagome K, Iwanami A, Fukuda M, Itoh K, Koshida I, Kato N. No effect of gender on tonal and phonetic mismatch negativity in normal adults assessed by a high-resolution EEG recording. *Cognitive Brain Research* 13, 305-312, 2002.
 49. Kasai K, Yamada H, Kamio S, Nakagome K, Iwanami A, Fukuda M, Yumoto M, Itoh K, Koshida I, Abe O, Kato N. Do High or low doses of anxiolytics and hypnotics affect mismatch negativity in schizophrenic subjects? An EEG and MEG study. *Clinical Neurophysiology* 113, 141-150, 2002.
 50. Watanabe A, Kasai K, Nagakubo S, Kamio S, Murakami T, Hata A, Iwanami A, Nakagome K, Fukuda M, Kato N. Verbal and procedural memory in schizophrenia with milder symptoms: implications for psychosocial intervention. *Schizophrenia Research* 53, 263-265, 2002.

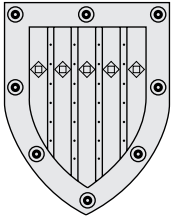

Department of Neurology

Outline and Research Objectives

The Department of Neurology as a division of clinical service in The University Hospital was established in 1964 separated from the third Department of Internal Medicine. The facilities for research in neurology were provided from the Faculty of Medicine as a division of clinical research in the Institute for Brain Research until March 1997. In April 1997, our department was reorganized as a Department in the Division of Neuroscience, Graduate School of Medicine.

Activities of our department include 1. clinical service in the out-patient clinic and the ward in the University Hospital, 2. undergraduate and postgraduate education of neurology in the Faculty of Medicine and Graduate School of Medicine, and 3. research in neuroscience in the Graduate School of Medicine. Besides a weekly ward round, a weekly clinical conference is held for discussion on cases with difficult problems. A weekly neuroimaging conference and journal club are also held. Moreover, a bimonthly "Neuroscience Club" with stimulating discussions is held where informal lectures are given by invited distinguished guests in the field of neuroscience from outside the University.

The Research Objectives of the Department of Neurology is to elucidate molecular mechanisms of neurological diseases and development of new therapeutic strategies based on our understanding of molecular mechanisms of neurological diseases.

Faculties and Students

Professor and Chair	Shoji Tsuji, MD, PhD (2002)
Associate Professors	Shin Kwak, MD, PhD (1997)
Lecturer	Susumu Kusunoki, MD, PhD (1999)
Lecturer	Yoshikazu Ugawa, MD, PhD (1997)
Associate	4
Graduate student	18

Past Research and Major Accomplishments

The research activities have been focused on elucidation of molecular mechanisms of neurodegenerative diseases based on molecular genetics approaches. We took a strategy for collecting as many as families with various hereditary neurological diseases. We have conducted a number of projects that include linkage mapping and eventual positional cloning of the causative genes. For the diseases in which we discovered the causative genes, analyses of molecular mechanisms of neurodegeneration have been conducted.

1. Identification of causative genes for neurodegenerative diseases

By linkage analysis, we have identified the loci for Machado-Joseph disease (Nature Genet. 4:300-304, 1993), hereditary progressive dystonia (Segawa disease) (Ann. Neurol. 37:405-408, 1995) and autosomal

recessive Parkinsonism (AR-JP) (Am. J. Hum. Genet. 60:588-596, 1997). Furthermore we have identified the causative gene for dentatorubral-pallidolusian atrophy (DRPLA) (Nature Genet. 6:9-13, 1994), hereditary progressive dystonia (Nature Genet. 8:236-242, 1994), spinocerebellar ataxia type 2 (SCA2), early-onset ataxia with ocular motor apraxia and hypoalbuminemia (EAOH) (Nature Genet. 29: 184-188, 2001), Charcot-Marie-Tooth disease type 2 (CMT2) (Cell 105:587-597, 2001) and SCA17 (Hum. Mol. Genet. 8:2047-2053, 1999, Hum. Mol. Genet. 10: 1441-1448, 2001).

2. Elucidation of molecular pathogenesis of neurodegenerative diseases

Based on identification of causative genes for the abovementioned neurodegenerative diseases, our laboratory further expanded our studies to elucidate the molecular mechanisms of neurodegeneration in these diseases. Our major effort has been focused on molecular mechanisms of neurodegeneration in polyglutamine diseases caused by expanded CAG repeats coding for polyglutamine stretches. We have created transgenic mice having a full-length human mutant DRPLA gene as a single copy, which carry various lengths of polyglutamine stretches (Q76, Q113 and Q129 mice at the same insertion site). The expression levels of the transgene were comparable to those of endogenous mouse DRPLA gene. Q129 mice showed severe neurological phenotype including ataxia,

Figure. Molecular mechanisms of neuronal degeneration

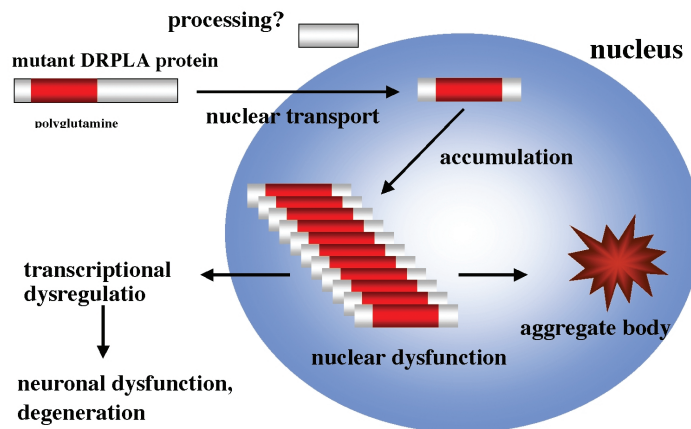

myoclonus and epilepsy with premature death by 16 weeks, while Q76 mice did not show any obvious phenotypes. Q113 mice showed milder phenotypes compared with those of Q129 mice. Given the fact that the insertion site of the transgene (human full-length mutant DRPLA gene) is identical in these Q129, Q113 and Q76 mice, these data strongly suggest that the variability in the phenotypes exclusively depends on the length of the polyglutamine stretches. Interestingly, neuronal loss was not evident in the brains of these mice, suggesting that neuronal dysfunction not but neuronal death underlies the basic pathophysiologic mechanisms of neurodegeneration. Detailed analysis of these mice demonstrated that the earliest neuropathological change was intranuclear accumulation of mutant proteins (diffuse nuclear staining) with preferential involvement of cerebellar nuclei, red nuclei, globus pallidus, subthalamic nuclei and cerebral cortex. Similar findings were also confirmed in human autopsied brains of DRPLA patients. These data strongly suggest that neuronal dysfunction is the basic molecular mechanisms of neurodegeneration in polyglutamine diseases.

Given the fact that nuclear dysfunction underlies the molecular mechanisms of neuronal degeneration in polyglutamine diseases, we investigated nuclear proteins that bind to expanded polyglutamine stretches. Employing yeast two-hybrid assays, we have found TAF130 (TATA-binding protein associated factor) binds to expanded polyglutamine stretches. The association was further confirmed by co-localization of TAF130 and expanded polyglutamine stretches not only in transient expression assays but also in human autopsied brains of DRPLA and MJD patients. Since TAF130 is involved in CREB-dependent transcriptional activation, association between TAF130 and expanded polyglutamine stretches raised the possibilities that suppression of CREB-dependent transcription, which has been demonstrated to be essential for neuronal survival and plasticity, leads to neuronal

dysfunctions. Suppression of CREB-dependent transcription by expanded polyglutamine stretches was confirmed by a reporter assay, and, furthermore, by monitoring endogenous cAMP responsive genes such as c-FOS. Expression profiling of the Q129 mouse brains further demonstrated down-regulation of many cAMP responsive genes including c-FOS and EGR-1.

To develop therapeutic approaches for polyglutamine disease, we have investigated possibilities for abrogating suppression of CREB-dependent transcriptional activation. We found that increase in intracellular cAMP levels abrogate the suppression of the CREB-dependent transcriptional activation. We have further demonstrated that histone deacetylase (HDAC) inhibitor has similar effects. Thus, stimulation of transcription by cAMP or HDAC inhibitors has potential roles in therapeutic measures for polyglutamine diseases.

Current Research

1. Molecular pathogenesis of polyglutamine diseases

Current research is being focused to the following points. 1. Detailed analyses of transcriptional dysregulation in polyglutamine diseases. 2. Development of therapeutic measures based on the molecular pathogenesis of polyglutamine diseases.

For elucidating the mechanisms of transcriptional dysregulation, detailed expression profiling analyses of the Q129, Q113 and Q76 mice are being conducted. Similar expression profiling of human autopsied brains of patients with polyglutamine diseases is also being conducted. Abnormalities in CREB-dependent transcriptional activation in vivo are also being investigated by generating double transgenic mice for DRPLA and Cre-LacZ (Lac-Z gene was inserted under the promoter containing CRE.),

For development of therapeutic approaches, the

possibilities of increasing intracellular cAMP and administration of HDAC inhibitors are being investigated. To further establish a sensitive assay system, a sensitive assay system for CREB-dependent transcriptional activation using cultured cells is being developed.

2. Molecular pathogenesis of neurodegenerative diseases caused by deficiency in DNA repair

We have recently identified the causative gene, aprataxin, for an autosomal recessive spinocerebellar ataxia (early-onset ataxia associated with ocular motor apraxia and hypoalbuminemia). Preliminary studies suggest that aprataxin binds to XRCC-1, a key molecule involved in single strand DNA break repair. The hypothesis that XRCC-1 is involved in the single strand DNA break repair is further supported by the fact that aprataxin has a polynucleotide kinase-like domain.

Since a number of neurodegenerative diseases with mutations in the DNA repair systems have already been found, our finding further strengthens the functional role of DNA repair system in neurodegenerative diseases. Since the role of single strand DNA repair system in neurodegenerative diseases has not been well established, the future research will be focused on the roles of single strand DNA break repair in neurodegenerative diseases. The fact that hypoalbuminemia becomes evident only in adulthood further raises the possibility that transcription-coupled repair of highly actively transcribed genes such as albumin gene might be involved in this disease. This hypothesis is intriguing, since brain is the organ with highly active transcription activities.

3. Molecular pathogenesis of neurodegenerative diseases with complex trait

To elucidate molecular pathogenesis of sporadic neurodegenerative disease, we are organizing a consortium to establish a nation-wide collaborative network. To elucidate the molecular pathogenesis of such neurodegenerative diseases with complex trait, we need to establish large databases and to collect as many as samples. We are focusing on amyotrophic lateral sclerosis (sporadic ALS, and ALS in Kii Peninsula) and multiple system atrophy. Effort is being made to collect as many as multiple families for ALS and multiple system atrophy. We are performing both linkage analysis based on multiplex families and association studies (case-control studies). These two strategies will complement each other.

Future Prospects

For future prospects, the following projects are being planned.

1. Development of therapeutic measures for polyglutamine diseases.

For accomplishing this goal, various approaches are being planned. Considering the cascade shown in the above Figure, the therapeutic approaches should be focused on 1. suppression of mutant gene expressions at the upstream cascade, and 2. enhancement of CREB-dependent transcriptional activation at the downstream cascade will be the two major targets.

2. Molecular pathogenesis of neurodegenerative diseases caused by deficiency in DNA repair

Detailed reconstruction studies will be conducted to elucidate the physiological functions of aprataxin. Knock-out mice for aprataxin gene are being generated, which should be essential not only for elucidation of molecular pathogenesis, but also development of therapeutic approaches.

3. Molecular pathogenesis of neurodegenerative diseases with complex trait

To elucidate the molecular mechanisms of neurodegeneration of sporadic diseases, the following strategies are being planned. 1. large-scale collection of resources including database on clinical information and genomic DNAs based on a nation-wide consortium will be essential for future research. The collection of resources will be focused on a large scale case and controls, as well as, intensive collection of multiplex families. For example, we have recently identified 4 multiplex families with multiple system atrophy (MSA), suggesting detailed genome-wide analyses of these families may provide important findings as to the genetic component involved in these diseases. These two approaches (large scale case-control studies and intensive analyses of multiplex families) should complement, and allow us to identify the genes involved in the pathogenesis.

Research Grants

Grant for the Research for the Future Program from the Japan Society for the Promotion of Science, a grant from the Research Committee for Ataxic Diseases, the Ministry of Health, Labor and Welfare,

"Identification of Genes Involved in Brain Diseases"

FY1996	94,998
FY1997	75,682
FY1998	78,658
FY1999	85,516
FY2000	76,286
FY2001	50,000
FY2002	47,000

in thousands of yen

Grant for Scientific Research on Priority Areas (C) - Advanced Brain Science Project- from the Ministry of Education, Culture, Sports, and Science and Technology, Japan "Molecular mechanisms of neurodegeneration"

FY2001 66,600

FY2002/10/29 59,200

in thousands of yen

Grant for Scientific Research (A) from the Ministry of Education, Culture, Sports, and Science and Technology, Japan

FY2002 19,200

FY2003 11,300

in thousands of yen

Grant from the Ministry of Health, Labor and Welfare, Japan "Study for development of therapeutic measures for polyglutamine diseases!

FY1998 24,000

FY1999 24,000

FY2000 16,000

in thousands of yen

Select Publications

- 1 Naruse, S., Igarashi, S., Kobayashi, H., Aoki, K., Inuzuka, T., Kaneko, K., Shimizu, T., Iihara, K., Kojima, T., Miyatake, T. and Tsuji, S.: Mis-sense mutation Val→Ile in exon 17 of amyloid precursor protein gene in Japanese familial Alzheimers disease. *Lancet* 337:978-979, 1991
- 2 Wakamatsu, N., Kobayashi, H., Miyatake, T. and Tsuji, S.: A novel exon mutation in the human b-hexosaminidase b subunit gene affects 3 splice site selection. *J. Biol. Chem.* 267:2406-2413, 1992
- 3 Tsuji, S., Kobayashi, H., Uchida, Y., Ihara, Y. and Miyatake, T.: Molecular cloning of human growth inhibitory factor cDNA and its down-regulation in Alzheimers disease. *EMBO J.* 11:4843-4850, 1992
- 4 Igarashi, S., Tanno, Y., Onodera, O., Yamazaki, M., Sato, S., Ishikawa, A., Miyatani, N., Nagashima, M., Ishikawa, Y., Sahashi, K., Ibi, T., Miyatake, T. and Tsuji, S.: Strong correlation between the number of CAG repeats in androgen receptor genes and the clinical onset of features of spinal and bulbar muscular atrophy. *Neurol.* 42:2300-2302, 1992
- 5 Takiyama, Y., Nishizawa, M., Tanaka, H., Kawashima, S., Sakamoto, H., Karube, Y., Shimazaki, H., Soutome, M., Endo, K., Ohta, S., Kagawa, Y., Kanazawa, I., Mizuno, Y., Yoshida, M., Yuasa, T., Horikawa, Y., Oyanagi, K., Nagai, H., Kondo, T., Inuzuka, T., Onodera, O. and Tsuji, S.: The gene for Machado-Joseph disease maps to human chromosome 14q. *Nature Genet.* 4:300-304, 1993
- 6 Koide, R., Ikeuchi, T., Onodera, O., Tanaka, H., Igarashi, S., Endo, K., Takahashi, H., Kondo, R., Ishikawa, A., Hayashi, T., Saito, M., Tomoda, A., Miike, T., Naito, H., Ikuta, F. and Tsuji, S.: Unstable expansion of CAG repeat in hereditary dentatorubral-pallidoluysian atrophy (DRPLA). *Nature Genet.* 6:9-13, 1994
- 7 Okuizumi, K., Onodera, O., Tanaka, H., Kobayashi, H., Tsuji, S., Takahashi, H., Oyanagi, K., Seki, K., Tanaka, M., Naruse, S., Miyatake, T., Mizusawa, H. and Kanazawa, I.: ApoE-ε 4 and early-onset Alzheimers. *Nature Genet.* 7:10-11, 1994
- 8 Naruse, S., Igarashi, S., Furuya, T., Kobayashi, H., Miyatake, T. and Tsuji, S.: Structures of the human and mouse growth inhibitory factor-encoding genes. *Gene* 144:283-287, 1994
- 9 Ichinose, H., Ohye, T., Takahashi, E., Seki, N., Hori, T., Segawa, M., Nomura, Y., Endo, K., Tanaka, H., Tsuji, S., Fujita, K. and Nagatsu, T.: Hereditary progressive dystonia with marked diurnal fluctuation caused by mutations in the GTP cyclohydrolase I gene. *Nature Genet.* 8:236-242, 1994
- 10 Burke, J. R., Ikeuchi, T., Koide, R. and Tsuji, S.: Dentatorubral-pallidoluysian atrophy and Haw River syndrome. *Lancet* 344:1711-1712, 1994
- 11 Ikeuchi, T., Koide, R., Tanaka, H., Onodera, O., Igarashi, S., Takahashi, H., Kondo, R., Ishikawa, A., Tomoda, A., Miike, T., Sato, K., Ihara, Y., Hayabara, T., Isa, F., Tanabe, H., Tokiguchi, S., Hayashi, M., Shimizu, N., Ikuta, F., Naito, H. and Tsuji, S.: Dentatorubral-pallidoluysian atrophy closely related to unstable expansions of trinucleotide (CAG) repeat. *Ann. Neurol.* 37:769-775, 1995
- 12 Kaneko, K., Miyatake, T. and Tsuji, S.: Rapid and reliable diagnosis of tuberculous meningitis by PCR. *Neurol.* 45:1425-1426, 1995
- 13 Sanpei, K., Igarashi, S., Eguchi, I., Takiyama, Y., Tanaka, H. and Tsuji, S.: Direct detection of expanded (CAG/CTG) repeats in the myotonin-protein kinase genes of myotonic dystrophy patients using a high-stringency hybridization method. *Biochem. Biophys. Res. Commun.* 212:341-346, 1995
- 14 Okuizumi, K., Onodera, O., Namba, Y., Ikeda, K., Yamamoto, T., Seki, K., Ueki, A., Nanko, S., Tanaka, H., Takahashi, H., Oyanagi, K., Mizusawa, H., Kanazawa, I. and Tsuji, S.: Genetic association of the very low density lipoprotein (VLDL) receptor gene with sporadic Alzheimers disease. *Nature Genet.* 11:207-209, 1995
- 15 Onodera, O., Oyake, M., Takano, H., Ikeuchi, T., Igarashi, S. and Tsuji, S.: Molecular cloning of a full-length cDNA for dentatorubral-pallidoluysian atrophy and regional expressions of the expanded alleles in the CNS. *Am. J. Hum. Genet.* 57:1050-1060, 1995
- 16 Takiyama, Y., Igarashi, S., Rogaeva, E. A., Endo, K., Rogaev, E. I., Tanaka, H., Sherrington, R., Sanpei, K., Liang, Y., Saito, M., Tsuda, T., Takano, H., Ikeda, M., Lin, C., Chi, H., Kennedy, J. L., Lang, A. E., Wherrett, J. R., Segawa, M., Nomura, Y., Yuasa, T., Weissenbach, J., Yoshida, M., Nishizawa, M., Kidd, K. K., Tsuji, S. and St. George-Hyslop, P. H.: Evidence for inter-generational instability in the CAG repeat in the *MJD1* gene and for conserved haplotypes at flanking markers amongst Japanese and Caucasian subjects with Machado-Joseph disease. *Hum. Mol. Genet.* 4:1137-1146, 1995

- 17 Ikeuchi, T., Igarashi, S., Takiyama, Y., Onodera, O., Oyake, M., Takano, H., Koide, R., Tanaka, H. and Tsuji, S.: Non-Mendelian transmission in dentatorubral-pallidolusian atrophy and Machado-Joseph disease: The mutant allele is preferentially transmitted in male meiosis. *Am. J. Hum. Genet.* 58:730-733, 1996
- 18 Takano, H., Onodera, O., Takahashi, H., Igarashi, S., Yamada, M., Oyake, M., Ikeuchi, T., Koide, R., Tanaka, H., Iwabuchi, K. and Tsuji, S.: Somatic mosaicism of expanded CAG repeats in brains of patients with dentatorubral-pallidolusian atrophy: Cellular population-dependent dynamics of mitotic instability. *Am. J. Hum. Genet.* 58:1212-1222, 1996
- 19 Ishikawa, A. and Tsuji, S.: Clinical analysis of 17 patients in 12 Japanese families with autosomal-recessive type juvenile parkinsonism. *Neurol.* 47:160-166, 1996
- 20 Shimizu, N., Yamami, T., Nakayama, M., Ikeuchi, T., Koide, R. and Tsuji, S.: A sporadic case of dentatorubral pallidolusian atrophy (DRPLA) with CAG repeat expansion but no clinical abnormalities in the father. *J. Neurol. Neurosurg. Psychiat.* 61:113-114, 1996
- 21 Igarashi, S., Takiyama, Y., Cancel, G., Rogaeva, E.A., Sasaki, H., Wakisaka, A., Zhou, Y.-X., Takano, H., Endo, K., Sanpei, K., Oyake, M., Tanaka, H., Stevanin, G., Abbas, N., Durr, A., Rogaev, E.I., Sherrington, R., Tsuda, T., Ikeda, M., Cassa, E., Nishizawa, M., Benomar, A., Julien, J., Weissenbach, J., Wang, G.-X., Agid, Y., St. George-Hyslop, P.H., Brice, A. and Tsuji, S.: Intergenerational instability of the CAG repeat of the gene for Machado-Joseph disease (*MJD1*) is affected by the genotype of the normal chromosome: implications for the molecular mechanisms of the instability of the CAG repeat. *Hum. Mol. Genet.* 5:923-932, 1996
- 22 Okuizumi, K., Onodera, O., Seki, K., Tanaka, H., Namba, Y., Ideda, K., Saunders, A. M., Pericak-Vance, M. A., Roses, A. D. and Tsuji, S.: Lack of association of very low density lipoprotein receptor gene polymorphism with Caucasian Alzheimers disease. *Ann. Neurol.* 40:251-254, 1996
- 23 Sanpei, K., Takano, H., Igarashi, S., Sato, T., Oyake, M., Sasaki, H., Wakisaka, A., Tashiro, K., Ishida, Y., Ikeuchi, T., Koide, R., Saito, M., Sato, A., Tanaka, T., Hanyu, S., Takiyama, Y., Nishizawa, M., Shimizu, N., Nomura, Y., Segawa, M., Iwabuchi, K., Eguchi, I., Tanaka, H., Takahashi, H. and Tsuji, S.: Identification of the spinocerebellar ataxia type 2 gene using a direct identification of repeat expansion and cloning technique, DIRECT. *Nature Genet.* 14:277-284, 1996
- 24 Oyake, M., Onodera, O., Shiroishi, T., Takano, H., Takahashi, Y., Kominami, R., Moriwaki, K., Ikeuchi, T., Igarashi, S., Tanaka, H. and Tsuji, S.: Molecular cloning of murine homologue dentatorubral-pallidolusian atrophy (DRPLA) cDNA: Strong conservation of a polymorphic CAG repeat in the murine gene. *Genomics* 40:205-207, 1997
- 25 Matsumine, H., Saito, M., Shimoda-Matsubayashi, S., Tanaka, H., Ishikawa, A., Nakagawa-Hattori, Y., Yokochi, M., Kobayashi, T., Igarashi, S., Takano, H., Sanpei, K., Koike, R., Mori, H., Kondo, T., Mizutani, Y., Schaffer, A. A., Yamamura, Y., Nakamura, S., Kuzuhara, S., Tsuji, S. and Mizuno, Y.: Localization of a gene for an autosomal recessive form of juvenile parkinsonism to chromosome 6q25.2-27. *Am. J. Hum. Genet.* 60:588-596, 1997
- 26 Ikeuchi, T., Asaka, T., Saito, M., Tanaka, H., Higuchi, S., Tanaka, K., Saida, K., Uyama, E., Mizusawa, H., Fukuhara, N., Nonaka, I., Takamori, M. and Tsuji, S.: Gene locus for autosomal recessive distal myopathy with rimmed vacuoles maps to chromosome 9. *Ann. Neurol.* 41:432-437, 1997
- 27 Takiyama, Y., Sakoe, K., Soutome, M., Namekawa, M., Ogawa, T., Nakano, I., Igarashi, S., Oyake, M., Tanaka, H., Tsuji, S. and Nishizawa, M.: Single sperm analysis of the CAG repeats in the gene for Machado-Joseph disease (*MJD1*): evidence for non-Mendelian transmission of the *MJD1* gene and for the effect of the intragenic CCG/GGG polymorphism on the intergenerational instability. *Hum. Mol. Genet.* 6:1063-1068, 1997
- 28 Ikeuchi, T., Takano, H., Koide, R., Horikawa, Y., Honma, Y., Onishi, Y., Igarashi, S., Tanaka, H., Nakao, N., Sahashi, K., Tsukagoshi, H., Inoue, K., Takahashi, H. and Tsuji, S.: Spinocerebellar ataxia type 6: CAG repeat expansion in α 1A voltage-dependent calcium channel gene and clinical variations in Japanese population. *Ann. Neurol.* 42:879-884, 1997
- 29 Koide, R., Onodera, O., Ikeuchi, T., Kondo, R., Tanaka, H., Tokiguchi, S., Tomoda, A., Miike, T., Isa, F., Beppu, H., Shimizu, N., Watanabe, Y., Horikawa, Y., Shimohata, T., Hirota, K., Ishikawa, A. and Tsuji, S.: Atrophy of the cerebellum and brainstem in dentatorubral pallidolusian atrophy. Influence of CAG repeat size on MRI findings. *Neurol.* 49:1605-1612, 1997
- 30 Saito, M., Hayashi, Y., Suzuki, T., Tanaka, H., Hozumi, I. and Tsuji, S.: Linkage mapping of the gene for Charcot-Marie-Tooth disease type 2 to chromosome 1p (CMT2A) and the clinical features of CMT2A. *Neurol.* 49:1630-1635, 1997
- 31 Shimohata, T., Date, H., Ishiguro, H., Suzuki, T., Takano, H., Tanaka, H., Tsuji, S. and Hirota, K.: Ataxia with isolated vitamin E deficiency and retinitis pigmentosa. *Ann. Neurol.* 43:273, 1997
- 32 Igarashi, S., Koide, R., Shimohata, T., Yamada, M., Hayashi, Y., Takano, H., Date, H., Oyake, M., Sato, T., Sato, A., Egawa, S., Ikeuchi, T., Tanaka, H., Nakano, R., Tanaka, K., Hozumi, I., Inuzuka, T., Takahashi, H. and Tsuji, S.: Suppression of aggregate formation and apoptosis by transglutaminase inhibitors in cells expressing truncated DRPLA protein with an expanded polyglutamine stretch. *Nature Genet.* 18:111-117, 1998
- 33 Onodera, O., Idezuka, J., Igarashi, S., Takiyama, Y., Endo, K., Takano, H., Oyake, M., Tanaka, H.,

- Inuzuka, T., Hayashi, T., Yuasa, T., Ito, J., Miyatake, T. and Tsuji, S.: Progressive atrophy of cerebellum and brainstem as a function of age and the size of the expanded CAG repeats in the *MJD1* gene in Machado-Joseph disease. *Ann. Neurol.* 43:288-296, 1998
- 34 Takano, H., Cancel, G., Ikeuchi, T., Lorenzetti, D., Mawad, R., Stevanin, G., Didierjean, O., Durr, A., Oyake, M., Shimohata, T., Sasaki, R., Koide, R., Igarashi, S., Hayashi, S., Takiyama, Y., Nishizawa, M., Tanaka, H., Zoghbi, H., Brice, A., Tsuji, S.: Close associations between prevalence rates of dominantly inherited spinocerebellar ataxias with CAG-repeat expansions and frequencies of large normal CAG alleles in Japanese and Caucasian populations. *Am. J. Hum. Genet.* 63:1060-1066, 1998
- 35 Koide, T., Igarashi, S., Kikugawa, K., Nakano, R., Inuzuka, T., Yamada, M., Takahashi, H. and Tsuji, S.: Formation of granular cytoplasmic aggregates in cells expressing mutant Cu/Zn superoxide dismutase associated with familial amyotrophic lateral sclerosis. *Neurosci. Lett.* 257:29-32 1998
- 36 Okuizumi, K., Takano, H., Seki, K., Onishi, Y., Horikawa, Y. and Tsuji, S.: Genetic polymorphism of the tau gene and neurodegenerative diseases with tau pathology among Japanese. *Ann. Neurol.* 44:707, 1998
- 37 Sato, T., Oyake, M., Nakamura, K., Nakao, K., Fukusima, Y., Onodera, O., Igarashi, S., Takano, H., Kikugawa, K., Ishida, Y., Shimohata, T., Koide, R., Ikeuchi, T., Tanaka, H., Futamura, N., Matsumura, R., Takayanagi, T., Tanaka, F., Sobue, G., Komure, O., Takahashi, M., Sano, A., Ichikawa, Y., Goto, J., Kanazawa, I., Katsuki, M. and Tsuji, S.: Transgenic mice harboring a full-length human mutant DRPLA gene exhibit age-dependent intergenerational and somatic instabilities of CAG repeats comparable to those in DRPLA patients. *Hum. Mol. Genet.* 8:99-106, 1999
- 38 Takano, H., Koike, R., Onodera, O., Sasaki, R. and Tsuji, S.: Mutational analysis and genotype-phenotype correlation of 29 unrelated Japanese patients with X-linked adrenoleukodystrophy (ALD). *Arch. Neurol.* 56:295-300, 1999
- 39 Ikeuchi, T., Shimohata, T., Nakano, R., Koide, R., Takano, H. and Tsuji, S.: A case of primary torsion dystonia in Japan with the 3-bp (CAG) deletion in the *DYT1* gene with a unique clinical presentation. *Neurogenetics* 2:189-190, 1999
- 40 Sato, A., Shimohata, T., Koide, R., Takano, H., Sato, T., Oyake, M., Igarashi, S., Tanaka, K., Inuzuka, T., Nawa, H. and Tsuji, S.: Adenovirus-mediated expression of mutant DRPLA proteins with expanded polyglutamine stretches in neuronally differentiated PC12 cells. Preferential intranuclear aggregate formation and apoptosis. *Hum. Mol. Genet.* 8:997-1006, 1999
- 41 Koide, R., Kobayashi, S., Shimohata, T., Ikeuchi, T., Maruyama, M., Saito, M., Yamada, M., Takahashi, H. and Tsuji, S.: A neurological disease caused by an expanded CAG trinucleotide repeat in the TATA-binding protein gene: a new polyglutamine disease? *Hum. Mol. Genet.* 8:2047-2053, 1999
- 42 Schilling, G., Wood, J. D., Duan, K., Slunt, H. H., Gonzales, V., Yamada, M., Cooper, J. K., Margollis, R. L., Jenkins, N. A., Copeland, N. G., Takahashi, H., Tsuji, S., Price, D. L., Borchelt, D. R. and Ross, C. A.: Nuclear accumulation of truncated atrophin-1 fragments in a transgenic mouse model of DRPLA. *Neuron* 24:275-286, 1999
- 43 Shibasaki, Y., Tanaka, H., Iwabuchi, K., Kawasaki, S., Kondo H., Uekawa, K., Ueda, M., Kamiya, T., Katayama, Y., Nakamura, A., Takashima, H., Nakagawa, M., Masuda, M., Utsumi, H., Nakamuro, T., Tada, K., Kurohara, K., Inoue, K., Koike, F., Sakai, T., Tsuji, S. and Kobayashi, H.: Linkage of autosomal recessive hereditary spastic paraplegia with mental impairment and thin corpus callosum to chromosome 15q13-15. *Ann. Neurol.* 48:108-112, 2000
- 44 Maruyama, M., Ikeuchi, T., Saito, M., Ishikawa, A., Yuasa, T., Tanaka, H., Hayashi, S., Wakabayashi, K., Takahashi, H. and Tsuji, S.: Novel mutations, pseudo-dominant inheritance, and possible familial affects in patients with autosomal recessive juvenile parkinsonism. *Ann. Neurol.* 48:245-250, 2000
- 45 Shimohata, T., Nakajima, T., Yamada, M., Uchida, C., Onodera, O., Naruse, S., Kimura, T., Koide, R., Nozaki, K., Sano, Y., Ishiguro, H., Sakoe, K., Ooshima, T., Sato, A., Ikeuchi, T., Oyake, M., Sato, T., Aoyagi, Y., Hozumi, I., Nagatsu, T., Takiyama, Y., Nishizawa, M., Goto, J., Kanazawa, I., Davidson, I., Tanese, N., Takahashi, H. and Tsuji, S.: Expanded polyglutamine stretches associated with CAG repeat diseases interact with TAFII130, interfering with CREB-dependent transcription. *Nature Genet.* 26:29-35, 2000
- 46 Zhao, C., Takita, J., Tanaka, Y., Setou, M., Nakagawa, T., Takeda, S., Yang, H.W., Terada, S., Nakata, T., Takei, Y., Saito, M., Tsuji, S., Hayashi, Y. and Hirokawa, N.: Charcot-Marie-Tooth disease type 2A caused by mutation in a microtubule motor KIF1B β . *Cell* 105:587-597, 2001
- 47 Nakamura, K., Jeong, S.E., Uchihara, T., Anno, M., Nagashima, K., Nagashima, T., Ikeda, S., Tsuji, S. and Kanazawa, I.: SCA17, a novel autosomal dominant cerebellar ataxia caused by an expanded polyglutamine in TATA-binding protein. *Hum. Mol. Genet.* 10: 1441-1448, 2001
- 48 Date, H., Onodera, O., Tanaka, H., Iwabuchi, K., Uekawa, K., Igarashi, S., Koike, R., Hiroi, T., Yuasa, T., Awaya, Y., Sakai, T., Takahashi, T., Nagatomo, H., Sekijima, Y., Kawachi, I., Takiyama, Y., Nishizawa, M., Fukuhara, N., Saito, K., Sugano, S. and Tsuji, S.: Early-onset ataxia with ocular motor apraxia and hypoalbuminemia is caused by mutations in a new HIT superfamily gene. *Nature Genet.* 29: 184-188, 2001
- 49 Takahashi T., Igarashi S., Kimura T., Hozumi I., Kawachi I., Onodera O., Takano H., Saito M. and Tsuji S.: Japanese cases of familial hemiplegic migraine with cerebellar ataxia carrying a T666M

mutation in the CACNA1A gene. J. Neurol. Neurosurg. Psychiat. 72: 675-680, 2002

- 50 Shimohata, T., Sato, A., Burke, J.R., Strittmatter, W.J., Tsuji S., Onodera, O.: Expanded polyglutamine stretchers form an 'aggresome'. Neuroscience Letters 323: 215-218, 2002

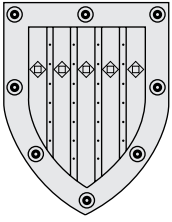

Department of Neurosurgery

Outline and Research Objectives

The Department of Neurosurgery focuses its academic activities on patient care, research, and education. Services of the Neurosurgical Clinic are devoted to the care of patients who suffer from brain tumors, cerebrovascular disorders, head injuries, spinal diseases, malformations of the central nervous system, and functional disturbances of the brain. The research objectives of the department are based on these neurosurgical diseases. Clinical research has been performed by analyzing many neurosurgical cases. The attempts to develop new neurosurgical techniques are ongoing. Since the first Gamma-knife unit in this country was installed in 1991, many studies have been conducted which analyze the outcome of patients treated by this modality. To solve problems encountered in a clinical setting, cell biology and molecular biology of ischemic brain injury and brain tumors have been pursued as the two major research subjects. The research on ischemic brain damage has been carried out using rodent ischemia models. The objective of the research has been to determine the molecular mechanism underlying delayed neuronal death in the hippocampus following ischemia, but it has recently shifted toward the research on neuronal regeneration in the hippocampus by activation of endogenous progenitor cells. The research on brain tumors has mainly focused on the genetic analysis of tumor specimens obtained during neurosurgery. This research strategy has particularly employed the genetic analysis of malignant brain tumors.

Faculty and Students

Professor and Chair	Takaaki Kirino, M.D., Ph.D. (1992~)
Associate Professor	Akio Morita, M.D, Ph.D.
Lecturer	Nobutaka Kawahara, M.D., Ph.D.
Lecturer	Tomoki Todo, M.D., Ph.D.
Associates	8
Graduate Students	7
Research Students.....	3
Secretaries	5
Research assistants	2
Residents.....	6

Past Research and Major Accomplishments

The research performed by our department has been divided into three categories: clinical research, basic research on ischemic brain damage, and basic research on brain tumors.

Research of clinical materials has been encouraged since it may be effective in improving current and future patient care. Most clinical publications by this department are case studies, such as the rupture of intracranial aneurysms (16, 17, 22, 25, 34, 41), arteriovenous or venous malformations (11, 32, 46), brain tumors (8, 15, 21), and other disorders (13). The results of Gamma-knife radiosurgery (6, 10, 12, 14, 19, 20, 33, 43) and the theoretical or technical aspect of neurosurgical treatment (18, 23, 38, 50) have also

been published. Thirty-two case reports have been published by this department in English (not listed in the references).

Our department has been continuously undertaking basic research as well. Currently, our basic research consists mainly of studies on ischemic brain damage and brain tumors. In our neurosurgical laboratory, one of the features is *in vivo* experiment using our microsurgical techniques on small animals. Another advantage of our laboratory is the availability of various specimens that are obtained during neurosurgical operations. In addition, we are rapidly expanding our research facility to take advantage of state-of-the-art techniques in cell and molecular biology. We collaborate with various laboratories of basic science and departments of engineering in an attempt to expand our future possibilities in clinical and research activities. Some of the major accomplishments in basic research in our department have been possible by mutual collaborations with such laboratories.

Research on ischemic brain damage

When the brain is subjected to transient ischemia, the first detrimental event in the brain tissue is depletion of ATP and it is followed by anoxic depolarization of the neuronal membrane and a massive increase in the extracellular glutamate level. Glutamate is believed to be the major factor that

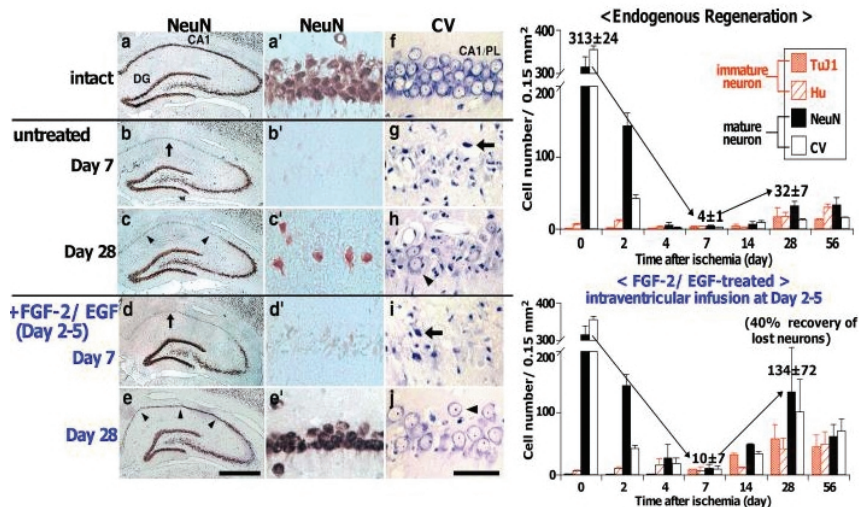

Figure 1: A small, but significantly higher number of mature neurons in the CA1 are seen at Day 28 (c, c', h). When FGF-2 and EGF are infused into the lateral ventricle of ischemic animals, CA1 pyramidal neurons degenerates extensively at Day 7 (d, d'), but the number of neurons later after ischemia markedly increases (e, e', j). (Cited and modified from Nakatomi et al. Cell 110:429-441,2002⁵)

injures the brain tissue during the early phase of cerebral ischemia. We attempted to examine the validity of this hypothesis by inducing focal cerebral ischemia in mice deficient in the $\epsilon 1$ (NR2A) subunit of the NMDA receptor (39) in collaboration with Dr. Mishina of the Department of Molecular Neurobiology of this Graduate School. This experiment revealed that the brain deficient in glutamate neurotransmission is less vulnerable to ischemic insult.

The precise mechanism underlying ischemic brain injury that follows the initial extracellular glutamate surge and influx of Ca^{2+} remained unclear. Since a very brief ischemic insult can induce ischemic tolerance in the hippocampus (37), we postulated that the underlying mechanism is related to events induced by neuronal stress response. We found that significant changes in hsp70 and ubiquitin expression occur following brief transient ischemia (28, 49). The hsp70 message and protein levels increase in tolerance-induced brain tissue. Ubiquitin expression pattern is very similar to that of hsp70. When CA1 neurons die following ischemia, free ubiquitin is severely depleted, and at the same time, the level of conjugated ubiquitin increases. These findings led to the hypothesis that a disturbance in proteasomal function is the initial event that leads to neuronal apoptosis. We confirmed that under culture conditions proteasomal inhibitors induce cytochrome-c- and caspase-3-like protease-induced apoptosis (24). Then, we directly measured the proteasomal activity in the hippocampal CA1 region. This study demonstrated the selective proteasomal dysfunction in the CA1 sector after transient cerebral ischemia (1). This finding indicates that the protein-degrading system plays a major role in ischemic neuronal death following brief cerebral ischemia.

The decrease in the free ubiquitin level following brief cerebral ischemia may be attributed to protein degradation by activation of intracellular proteases, by direct protein denaturation, or by an increase in the level of nascent protein molecules as a result of disturbed protein synthesis. We have confirmed the disturbance of protein ubiquitination and, at the same time, inhibition of proteasomal function in CA1 neurons following brief cerebral ischemia. The mechanism of this dysfunction, however, is yet to be clarified. We hypothesized that activation of calcineurin, an intracellular protein phosphatase, is somehow related to proteasomal dysfunction since calcineurin inhibitor FK506 protects CA1 neurons following ischemia (47) and overexpression of calcineurin kills cultured glial cells and neurons (27). This hypothesis has not been fully tested.

Following brief ischemia, most of CA1 pyramidal cells die during 3-4 days following ischemia. The area becomes almost devoid of neurons and finally falls in classic gliosis. However, a close observation of this region for several weeks revealed a small but significant increase in the number of neurons in the CA1 subfield. Dr. Nakatomi (a graduate student of our department at that time) and Dr. Nakafuku (associate professor, Department of Neurobiology of this Graduate School) examined the possibility that the increased neurons are derived from endogenous neural progenitor cells (5). The result was positive. In addition, intraventricular infusion of FGF-2 and EGF resulted in a more than 40% increase in neuronal population in the CA1 region. The regenerated hippocampi by this procedure exhibited electrical activity when examined using slice preparations. The animals that had regenerated hippocampi performed better in the Morris water-maze task than the controls. We presented evidence that endogenous neural progenitors

can be induced *in situ* to replace the hippocampal neurons lost by ischemia. We further showed that regenerated neurons contribute to ameliorating ischemia-induced deficits in spatial cognitive functions, thus expanding the possibility of a novel neuronal replacement therapy for stroke. The neuronal changes in the CA1 sector are shown in Figure 1.

We have published other experimental results on cerebral ischemia (2, 26, 29) and on the cell biology of cerebral blood vessels (9, 31, 48).

Research on brain tumors

Basic research on brain tumors conducted by our department has been based on specimens obtained during surgery and those donated by affiliated hospitals. A portion of these specimens were fixed in aldehyde fixatives (formalin) and embedded in paraffin. These materials were used for cellular analyses by MIB-1 staining and other immunostaining techniques. The remaining specimens were stored frozen until use for genetic analysis. We have examined many types of brain tumors such as meningiomas, oligodendrogliomas, and neurinomas in NF2 (neurofibromatosis type 2) patients.

Mutation of the NF2 genes was detected in 20-30% of sporadic meningiomas, whereas loss of heterozygosity (LOH) at chromosome 22q was found at a much higher frequency (35). To determine the correlation of merlin loss with NF2 genetic alteration, we performed a molecular genetic analysis of 50 sporadic meningiomas. Findings of this study strongly support the notion that NF2 is the sole target of 22q LOH in meningiomas and that the loss of merlin expression is always caused by alteration of NF2 gene, according to the classic "two hit" theory. Oligodendrogliomas frequently, but not always, show sensitivity to chemotherapy. Recent studies demonstrated that allelic loss of chromosome 1p is highly associated with this chemosensitivity. To clarify the molecular mechanism of this correlation, we examined comprehensive gene expression profiles of oligodendrogliomas with and without 1pLOH along with normal brain tissue using oligonucleotide microarray (GeneChip) (4). This study showed that biological differences between genetic subsets of oligodendroglioma are indeed reflected on the gene expression profile. We encountered a very rare case of malignant transformation of vestibular schwannoma following stereotactic radiosurgery. Genotyping of this tumor showed a TP53 mutation in the recurrent tumor that did not exist in the original tumor, suggesting that radiosurgery induced the malignant transformation (6). We performed molecular genetic analysis on non-selected gliomas and found that molecular genetic analysis of 1p/19q/10q/TP53 has significant diagnostic value, especially in detecting oligodendroglial tumors.

In addition, 1pLOH and TP53 mutations in gliomas may be markers of oligodendroglial and astrocytic pathways, respectively (7). We reported a case of endolymphatic sac tumor, a rare adenomatous tumor of the temporal bone, in a patient with von Hippel-Lindau (VHL) disease. Sequencing and microsatellite analysis of DNA samples indicated that VHL gene inactivation contributed to the oncogenesis of endolymphatic sac tumor (30).

We examined brain tumor specimens to analyze MEN1 gene mutation (36), telomerase activity (40), MIB-1 in central neurocytoma (42), and proliferation of chordoma (44). We also published experimental data on cultured glioma cells (3, 45).

Current Research

We are continuously conducting clinical researches to improve neurosurgical technologies and future patient care in the neurological field. The department places strong emphasis on publishing clinical reports and particularly encourages young colleagues to do so. The objective of current clinical research in neurosurgery is gradually shifting to the improvement of less invasive neurosurgical procedures using microendoscope, navigation and robotic manipulators. This is now under way in collaboration with several departments in the Faculty of Engineering of our university. The department is involved in the nationwide epidemiological study of the incidentally-discovered unruptured cerebral aneurysms (Unruptured Cerebral Aneurysm Study of Japan, or UCAS Japan), and functions as the central office of this study.

We have been involved in experiments on the molecular mechanism underlying delayed neuronal death found in the hippocampal CA1 region following ischemia. Although we believe that this is a good model system for studying neuronal protection, experimental results obtained by us and other groups suggest that neuronal protection is extremely difficult and we are so far unable to propose clinically applicable methods of treatment. On the other hand, it turned out to be possible to induce practically meaningful regeneration of neurons in the hippocampal CA1 region by activating endogenous neural progenitor cells. Given these experimental results, we are now attempting to focus our experimental resources on experiments of regeneration of CA1 neurons.

We have been engaged in the genetic analysis of brain tumors. This strategy has been particularly effective for this department since comprehensive genetic analysis has been rapidly introduced and we can collect sufficient amounts of specimens during neurosurgical operations. This strategy is being continued but the focus on brain tumor experiments is now shifting toward research on treatment of malig-

nant brain tumors because Dr. Todo who has expertise in this field has just joined our department in January, 2003. He plans to start a clinical trial with genetically engineered retrovirus for the treatment of malignant brain tumors.

Future Prospects

We will continue to carry out our three major research projects: i.e., clinical research, research on ischemic brain damage, and research on brain tumors. However, the main focus of each project may change. The future projects that we expect to conduct in the next 4-5 years are:

1. Clinical research

The aim will be the technical improvement of less invasive neurosurgical procedures using micro-endoscope, navigation, robotic manipulators as well as other devices. We will continue large-scale clinical studies such as UCAS Japan. Clinical studies on neurosurgical cases will be continuously encouraged.

2. Research on ischemic brain damage:

The main objective will be regeneration of hippocampal neurons following brief cerebral ischemia. We will focus on the feasibility of activation of endogenous neural progenitors under a clinical setting. The research on the mechanism underlying ischemic brain damage and ischemic tolerance will be continued.

3. Research on brain tumors:

We will continue genetic analysis of brain tumor specimens. Along with this investigation, we will start clinical research on the treatment of malignant brain tumors.

Research Grants

1. Research grant from CREST (Core Research for Evolutional Science and Technology) by Japan Science and Technology Corporation "Molecular mechanism of delayed neuronal death", 1998-2002, ¥265,201,000
2. Research grant of 21st century medical development and promotion by the Ministry of Health, Labor and Welfare "Follow-up study of unruptured cerebral aneurysms diagnosed by brain check-up clinics", 1999-2001, ¥24,000,000
3. Research Grants in Natural Sciences by the Mitsubishi Foundation "Study of ischemic neuronal death and ischemic tolerance based on functional genomic/proteomic analysis", 2001, ¥7,000,000
4. Grant-in-Aid for Scientific Research (A) "Mechanism of ischemic cerebral damage by systematic expression analysis of genome and proteome", 2001-, ¥30,000,000

5. Research grant from SORST (Solution Oriented Research for Science and Technology) by Japan Science and Technology Corporation "Neuronal regeneration in the hippocampus following delayed neuronal death", 2002-, ¥75,000,000

Selected Papers (1995-2002)

1. Asai A, Tanahashi N, Qiu JH, Saito N, Chi S, Kawahara N, Tanaka K, Kirino T. Selective proteasomal dysfunction in the hippocampal CA1 region after transient forebrain ischemia. *J Cereb Blood Flow Metab* 22, 705-710, 2002
2. Kawahara N, Kawai K, Toyoda T, Nakatomi H, Furuya K, Kirino T. Cardiac arrest cerebral ischemia model in mice failed to cause delayed neuronal death in the hippocampus. *Neurosci Lett* 322, 91-94, 2002
3. Mochizuki T, Asai A, Saito N, Tanaka S, Katagiri H, Asano T, Nakane M, Tamura A, Kuchino Y, Kitanaka C, Kirino T. Akt protein kinase inhibits non-apoptotic programmed cell death induced by ceramide. *J Biol Chem* 277, 2790-2797, 2002
4. Mukasa A, Ueki K, Matsumoto S, Tsutsumi S, Nishikawa R, Fujimaki T, Asai A, Kirino T, Aburatani H. Distinction in gene expression profiles of oligodendrogliomas with and without allelic loss of 1p. *Oncogene* 21, 3961-3968, 2002
5. Nakatomi H, Kuriu T, Okabe S, Yamamoto S, Hatano O, Kawahara N, Tamura A, Kirino T, Nakafuku M. Regeneration of hippocampal pyramidal neurons after ischemic brain injury by recruitment of endogenous neural progenitors. *Cell* 110, 429, 2002
6. Shin M, Ueki K, Kurita H, Kirino T. Malignant transformation of a vestibular schwannoma after gamma knife radiosurgery. *Lancet* 360, 309-310, 2002
7. Ueki K, Nishikawa R, Nakazato Y, Hirose T, Hirato J, Funada N, Fujimaki T, Hojo S, Kubo O, Ide T, Usui M, Ochiai C, Ito S, Takahashi H, Mukasa A, Asai A, Kirino T. Correlation of histology and molecular genetic analysis of 1p, 19q, 10q, TP53, EGFR, CDK4, and CDKN2A in 91 astrocytic and oligodendroglial tumors. *Clin Cancer Res* 8, 196-201, 2002
8. Asano S, Ueki K, Suzuki I, Kirino T. Clinical features and medical treatment of male prolactinomas. *Acta Neurochir (Wien)* 143, 465-470, 2001
9. Hoya K, Asai A, Sasaki T, Kimura K, Kirino T. Expression of smooth muscle proteins in cavernous and arteriovenous malformations. *Acta Neuropathol (Berl)* 102, 257-263, 2001
10. Kawai K, Suzuki I, Kurita H, Shin M, Arai N, Kirino T. Failure of low-dose radiosurgery to control temporal lobe epilepsy. *J Neurosurg* 95, 883-887, 2001
11. Kurita H, Shin M, Ueki K, Kawamoto S, Kirino T. Congestive brain oedema associated with a pial arteriovenous malformation with impaired venous drainage. *Acta Neurochir (Wien)* 143, 339-342, 2001
12. Kurita H, Kawahara N, Asai A, Ueki K, Shin M, Kirino T. Radiation-induced apoptosis of oligodendrocytes in the adult rat brain. *Neurol Res* 23, 869-874, 2001

13. Oya S, Tsutsumi K, Ueki K, Kirino T. Reinduction of hyponatremia to treat central pontine myelinolysis. *Neurology* 57, 1931-1932, 2001
14. Shin M, Kurita H, Sasaki T, Kawamoto S, Tago M, Kawahara N, Morita A, Ueki K, Kirino T. Analysis of treatment outcome after stereotactic radiosurgery for cavernous sinus meningiomas. *J Neurosurg* 95, 435-439, 2001
15. Sora S, Ueki K, Saito N, Kawahara N, Shitara N, Kirino T. Incidence of von Hippel-Lindau disease in hemangioblastoma patients: the University of Tokyo Hospital experience from 1954-1998. *Acta Neurochir (Wien)* 143, 893-896, 2001
16. Tsutsumi K, Ueki K, Kirino T. Recurrent subarachnoid hemorrhage. *J Neurosurg* 94, 541-542, 2001
17. Tsutsumi K, Ueki K, Morita A, Usui M, Kirino T. Risk of aneurysm recurrence in patients with clipped cerebral aneurysms: results of long-term follow-up angiography. *Stroke* 32, 1191-1194, 2001
18. Fujimaki T, Kirino T. Combined transhorizontal-supracerebellar approach for microvascular decompression of trigeminal neuralgia. *Br J Neurosurg* 14, 531-534, 2000
19. Kurita H, Ueki K, Shin M, Kawamoto S, Sasaki T, Tago M, Kirino T. Headaches in patients with radiosurgically treated occipital arteriovenous malformations. *J Neurosurg* 93, 224-228, 2000
20. Kurita H, Kawamoto S, Sasaki T, Shin M, Tago M, Terahara A, Ueki K, Kirino T. Results of radiosurgery for brain stem arteriovenous malformations. *J Neurol Neurosurg Psychiatry* 68, 563-570, 2000
21. Matsuno A, Katakami H, Nagashima T, Teramoto A, Osamura RY, Kirino T. Growth hormone-releasing hormone expression in pituitary somatotroph adenomas, studied by immunohistochemistry and in situ hybridization using catalyzed signal amplification system. *Hum Pathol* 31, 789-794, 2000
22. Nakatomi H, Segawa H, Kurata A, Shiokawa Y, Nagata K, Kamiyama H, Ueki K, Kirino T. Clinicopathological study of intracranial fusiform and dolichoectatic aneurysms : insight on the mechanism of growth. *Stroke* 31, 896-900, 2000
23. Nishihara T, Teraoka A, Morita A, Ueki K, Takai K, Kirino T. A transparent sheath for endoscopic surgery and its application in surgical evacuation of spontaneous intracerebral hematomas. Technical note. *J Neurosurg* 92, 1053-1055, 2000
24. Qiu JH, Asai A, Chi S, Saito N, Hamada H, Kirino T. Proteasome inhibitors induce cytochrome c-caspase-3-like protease-mediated apoptosis in cultured cortical neurons. *J Neurosci* 20, 259-265, 2000
25. Tsutsumi K, Ueki K, Morita A, Kirino T. Risk of rupture from incidental cerebral aneurysms. *J Neurosurg* 93, 550-553, 2000
26. Zhu L, Saito N, Abe O, Okubo T, Yamada H, Kawahara N, Asai A, Kirino T. Changes in the apparent diffusion coefficient of water and T2 relaxation time in gerbil hippocampus after mild ischemia. *Neuroreport* 11, 3333-3336, 2000
27. Asai A, Qiu J, Narita Y, Chi S, Saito N, Shinoura N, Hamada H, Kuchino Y, Kirino T. High level calcineurin activity predisposes neuronal cells to apoptosis. *J Biol Chem* 274, 34450-34458, 1999
28. Ide T, Takada K, Qiu JH, Saito N, Kawahara N, Asai A, Kirino T. Ubiquitin stress response in postischemic hippocampal neurons under nontolerant and tolerant conditions. *J Cereb Blood Flow Metab* 19, 750-756, 1999
29. Kawahara N, Mishima K, Higashiyama S, Taniguchi N, Tamura A, Kirino T. The gene for heparin-binding epidermal growth factor-like growth factor is stress-inducible: its role in cerebral ischemia. *J Cereb Blood Flow Metab* 19, 307-320, 1999
30. Kawahara N, Kume H, Ueki K, Mishima K, Sasaki T, Kirino T. VHL gene inactivation in an endolymphatic sac tumor associated with von Hippel-Lindau disease. *Neurology* 53, 208-210, 1999
31. Kim P, Yoshimoto Y, Nakaguchi H, Mori T, Asai A, Sasaki T, Kirino T, Nonomura Y. Increased sarcolemmal permeability in the cerebral artery during chronic spasm: an assessment using DNA-binding dyes and detection of apoptosis. *J Cereb Blood Flow Metab* 19, 889-897, 1999
32. Kurita H, Kirino T. A longitudinal study of patients with venous malformations. *Neurology* 52, 1109-1110, 1999
33. Kurita H, Sasaki T, Tago M, Kaneko Y, Kirino T. Successful radiosurgical treatment of arteriovenous malformation accompanied by venous malformation. *AJNR Am J Neuroradiol* 20, 482-485, 1999
34. Tsutsumi K, Ueki K, Usui M, Kwak S, Kirino T. Risk of subarachnoid hemorrhage after surgical treatment of unruptured cerebral aneurysms. *Stroke* 30, 1181-1184, 1999
35. Ueki K, Wen Bin C, Narita Y, Asai A, Kirino T. Tight association of loss of merlin expression with loss of heterozygosity at chromosome 22q in sporadic meningiomas. *Cancer Res* 59, 5995-5998, 1999
36. Wenbin C, Asai A, Teramoto A, Sanno N, Kirino T. Mutations of the MEN1 tumor suppressor gene in sporadic pituitary tumors. *Cancer Lett* 142, 43-47, 1999
37. Kawahara N, Ide T, Saito N, Kawai K, Kirino T. Propentofylline potentiates induced ischemic tolerance in gerbil hippocampal neurons via adenosine receptor. *J Cereb Blood Flow Metab* 18, 472-475, 1998
38. Kim P, Wakai S, Matsuo S, Moriyama T, Kirino T. Bisegmental cervical interbody fusion using hydroxyapatite implants: surgical results and long-term observation in 70 cases. *J Neurosurg* 88, 21-27, 1998
39. Morikawa E, Mori H, Kiyama Y, Mishina M, Asano T, Kirino T. Attenuation of focal ischemic brain injury in mice deficient in the epsilon1 (NR2A) subunit of NMDA receptor. *J Neurosci* 18, 9727-9732, 1998
40. Sano T, Asai A, Mishima K, Fujimaki T, Kirino T. Telomerase activity in 144 brain tumours. *Br J Cancer* 77, 1633-1637, 1998

41. Tsutsumi K, Ueki K, Usui M, Kwak S, Kirino T. Risk of recurrent subarachnoid hemorrhage after complete obliteration of cerebral aneurysms. *Stroke* 29, 2511-2513, 1998
42. Fujimaki T, Matsuno A, Sasaki T, Toyoda T, Matsuura R, Ogai M, Kitanaka C, Asai A, Matsutani M, Kirino T. Proliferative activity of central neurocytoma: measurement of tumor volume doubling time, MIB-1 staining index and bromodeoxyuridine labeling index. *J Neurooncol* 32, 103-109, 1997
43. Kurita H, Sasaki T, Kawamoto S, Taniguchi M, Terahara A, Tago M, Kirino T. Role of radiosurgery in the management of cavernous sinus meningiomas. *Acta Neurol Scand* 96, 297-304, 1997
44. Matsuno A, Sasaki T, Nagashima T, Matsuura R, Tanaka H, Hirakawa M, Murakami M, Kirino T. Immunohistochemical examination of proliferative potentials and the expression of cell cycle-related proteins of intracranial chordomas. *Hum Pathol* 28, 714-719, 1997
45. Mishima K, Asai A, Kadomatsu K, Ino Y, Nomura K, Narita Y, Muramatsu T, Kirino T. Increased expression of midkine during the progression of human astrocytomas. *Neurosci Lett* 233, 29-32, 1997
46. Furuya K, Sasaki T, Suzuki I, Kim P, Saito N, Kirino T. Intramedullary angiographically occult vascular malformations of the spinal cord. *Neurosurgery* 39, 1123-1130, 1996
47. Ide T, Morikawa E, Kirino T. An immunosuppressant, FK506, protects hippocampal neurons from forebrain ischemia in the mongolian gerbil. *Neurosci Lett* 204, 157-160, 1996
48. Kim P, Yoshimoto Y, Iino M, Tomio S, Kirino T, Nonomura Y. Impaired calcium regulation of smooth muscle during chronic vasospasm following subarachnoid hemorrhage. *J Cereb Blood Flow Metab* 16, 334-341, 1996
49. Morimoto T, Ide T, Ihara Y, Tamura A, Kirino T. Transient ischemia depletes free ubiquitin in the gerbil hippocampal CA1 neurons. *Am J Pathol* 148, 249-257, 1996
50. Chang HS, Kirino T. Quantification of operative benefit for unruptured cerebral aneurysms: a theoretical approach. *J Neurosurg* 83, 413-420, 1995

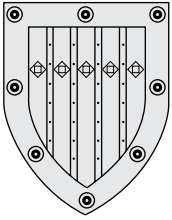

Department of Molecular Preventive Medicine

Outlines and Research objectives

This department originates from The Department of Hygiene which was first established by Prof. Masanori Ogata in 1885. Prof. Ogata is the first Japanese bacteriologist who was trained by Prof. Pettenkofer in Munich. The Department of Microbiology was separated in 1920. I (K.M.) am the 8th professor of this department.

Main current research interests are as follows:

1. Molecular pathogenesis of inflammatory and immune diseases focusing on chemokines and dendritic cells, and development of novel therapeutics for inflammatory and immune diseases.
2. Molecular mechanism of leukocyte trafficking in vivo and chemotaxis in vitro.
3. Development of novel, effective ways of dendritic cells(DC)-based vaccination for infectious and inflammatory diseases as well as cancer.
4. Identification of novel targets for intervention therapy and prevention of inflammatory and immune diseases through completing comprehensive gene expression profiling of human leukocyte subsets.

Faculties and Students

Professor and Chair	Kouji Matsushima MD and PhD (1996 appointed)
Associated Professor	Sho Ishikawa MD and PhD
Associate	2
Assistant	1
Postdoctoral Fellows.....	2 (JSP) 1 (SORST, JST)
Graduate Students	9
Graduate Students from outside	8
Visiting Scientists	5
Technical Assistants	1+1 (SORST, JST)
Secretary	1 (SORST, JST)

Past Major Accomplishments

Chemokine, chemotactic cytokine family now consists of over 40 and is subdivided into four subfamilies based on the location of the very conserved first two cysteine residues. Interleukin 8 (IL 8), which was purified based on in vitro neutrophil chemotactic activity and molecularly cloned by me in collaboration with Teizo Yoshimura in 1987, is a prototype of CXC chemokines. On the other hand, MCAF/MCP-1, which was purified based on monocyte chemotactic activity and molecularly cloned by me and Teizo Yoshimura independently in 1989, is a prototype of CC chemokines.

From the beginning of the 1990's we and several other groups initiated the studies to establish the pathophysiological roles of chemokines in various animal inflammation models using specific blocking antibodies against chemokines. We reported the essential

involvement of IL 8 in recruiting neutrophils in acute inflammation models such as LPS/IL-1 induced dermatitis, immune-complex induced acute glomerulonephritis, lung reperfusion injury, acute respiratory distress syndrome and brain infarct; and that intervention of IL 8 leads to the prevention of neutrophil infiltration-associated tissue injury. We also revealed the pivotal role of MCAF/MCP-1 in recruiting monocytes/macrophages in chronic inflammatory diseases through working on chronic glomerulonephritis caused by anti-glomerular basement membrane antibody, thickening of endothelium after carotid artery injury as an athelosclerosis model, and monocrotaline-induced pulmonary hypertension model in rats. Later, the pivotal role of IL 8 and MCAF/MCP-1 in recruiting neutrophils and monocytes, respectively was essentially confirmed by other groups analyzing gene targeted mice for IL 8 receptor homologue, and JE (murine homologue of MCAF/MCP-1) and its receptor CCR2.

Recent discovery of numerous novel chemokines by others through signal sequence trap method and EST data base, most of which are chemoattractants for immune cells such as subclasses of T lymphocytes, B lymphocytes and DC, has changed our understanding of the role of chemokines in host defense responses. For example, CD4+CD45RA+naive T lymphocytes express CCR7. CD4+CD45RO+memory T lymphocytes express CXCR3 and CCR5 on Th1 subset and CCR4 on Th2 subset. We generated a monoclonal antibody against human CCR4 and established that about 20% of CD4+ memory T lymphocytes in the circulation of normal individuals express CCR4 and

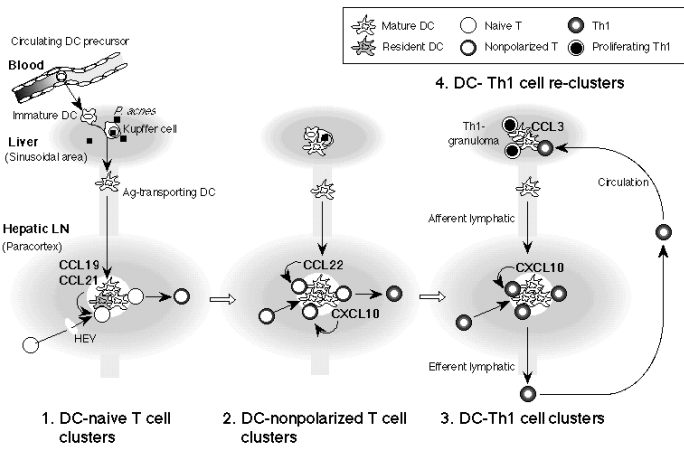

Figure 1: Peripheral and regional DC-Th cell clusters as the sites of Th1 cell generation regulated by DC-derived chemokines

these cells are committed Th2 population producing preferentially Th2 cytokines without any cultures to polarize into Th2 cells in vitro and the percentage of this population is much increased in atopic diseases such as atopic dermatitis and asthma. We also reported a pivotal role of the ligands for CCR4, TARC and MDC in causing and regulating atopic diseases in murine models.

Molecular pathogenesis of inflammatory and immune diseases

Chemokines in a murine model of bacteria-induced fulminant hepatitis

Propionibacterium acnes (P.acnes) is the most probable causing bacterium of sarcoidosis. In this model, administration of P.acnes causes numerous granuloma formation in the sinusoidal area of the liver, and subsequent challenge of the mice with low dose of LPS induces massive hepatic injury around granuloma. We first revealed that Th1 type immune response dominates in granuloma formation in terms of chemokine/chemokine receptor expression as well as cytokine production, whereas dramatic shift to Th2 response occurs immediately after LPS administration. Administration of the antibody against TARC (a ligand of CCR4, Th2 chemokine receptor) significantly inhibited liver injury. This is the first presentation that the rapid local shift from Th1 to Th2 by chemokines leads to severe tissue injury. We next identified TARC producing cells at the granuloma sites to be DC. We, then extensively analyzed the mechanism of granuloma formation, and revealed that numerous CCR1/5+DC-precursors appear shortly after P.acnes administration in the circulation and rapidly migrate into sub-sinusoidal area (Disse's space) in response to MIP1a produced by Kupffer cells to participate in the initial granuloma formation. Antigen-laden DC matured at the granuloma sites start to express CCR7, and subsequently migrate to portal area and the draining lymph nodes (hepatic/celiac lymph nodes) in response to SLC produced by lymphatic endothelium. We revealed that the first immune response occurs at the portal area and inflammation-associated lymphoid tissue appears at

the portal area which we termed "portal tract-associated lymphoid tissue, PALT. We also showed directly that Th1 polarization occurs at the draining lymph nodes by visualizing IFN-gamma producing CD4+T cells clustered with DC in the paracortex of lymph nodes. We provided evidence that IP-10 produced by migrated mature DC in the hepatic lymph nodes regulates DC-Th1 cluster formation and controls the exit of memory/effector T cells from the lymph nodes to home to the liver to complete granuloma formation (Figure 1). This is the first report describing the existence of DC at the granuloma sites and the identification of inflammation-associated DC precursors in the circulation. This implies that even the exit/release of memory/effector T cells from the peripheral lymph nodes is regulated by chemokines. This study has provided a new concept that chemokine-recruited DC tightly link inflammation (innate immunity) and acquired immunity. Inflammation and immunity should not be conceptually separated any more, and granuloma formation is not a mere end-point of chronic inflammation, rather a very active immune site.

1; Initiation and induction of DC-naive T cell clusters by ELC(CCL19) or SLC(CCL21). 2; Amplification of DC-nonpolarized T cell clusters by MDC(CCL22). 3; Promotion and retention of DC-Th1 cell clusters (this study). These clusters may develop in the given spaces of the paracortex called "cytokine fields". DC-derived chemokines may regulate T cell traffic depending on their state of activation between these given spaces to magnify the effective immune responses. After leaving the LNs, Th1 cells migrate into the liver through the circulation and 4. re-form clusters with peripheral tissue-resided inflammatory DCs (granuloma formation) possibly by MIP1a(CCL3) or Mig(CXCL9). Th1 cells can further proliferate and produce higher amount of IFN- γ at the periphery of the granulomas to complete polarization. HEV, high endothelial venule.

Current Research

DC migration pathway so far described is limited

to the idea that tissue immature DC such as Langerhans cells mature after antigen capturing and start to express CCR7 to be recruited to draining lymph nodes through afferent lymphatics. There is neither direct presentation of DC precursor migration into any organs nor evidence of the entry of DC into secondary lymph nodes through HEV (high endothelial venule) directly from the circulation. We have now identified DC precursors which rapidly appear in the circulation in inflammation. We are currently studying the following issues:

Mechanism of rapid release of DC precursors from bone marrow---identification of chemokine(s) involved.

Heterogeneity of the identified DC precursors and fate of DC precursors after administering into normal and inflamed mice. Most of cells are CD11c+CD11b+myeloid type DC, but some of the cells express L-selectin and B220. Therefore, some of these cells may directly enter peripheral lymph nodes through HEV to act as tolerance-inducing DC.

Identification of homing molecules to the lymph nodes.

Examination of the possible usefulness of the identified DC precursors for vaccination and antigen-specific tolerance induction.

Future Prospective: Investigation of "lymph node-homing" circulating DC precursors may provide a clue to the mechanism of systemic tolerance induction and an approach to establish effective way of DC-based vaccination to cancer and microbes. We will further examine the role of chemokines in Th2 polarization, CTL generation and the recruitment and maintenance of memory state of CD4/8 T lymphocytes. We will also establish the critical role of TARC/MDC to recruit CCR4+CD4+CD25+ so called regulatory T cells in cancer and chronic infection models. The clinical development of humanized monoclonal antibody against human CCR4 will be tried in a collaboration with a pharmaceutical. This antibody is expected to eliminate by ADCC CCR4+ cells such as Th2, regulatory T cells and adult leukemia cells in a few hours in vivo. Therefore, this antibody treatment may be useful for the treatment of various atopic diseases. This antibody may also be useful to recover patients from immune-suppression to respond more to DC-based vaccination. This antibody may also become an effective drug for curing ATL patients.

Research Grants

Research Grants from JSP
 1996 27,600,000 JPY
 1997 11,100,000 JPY
 2001 7,000,000 JPY

2002 20,300,000 JPY

Core Research of Evolutional Science and Technology (CREST, JST)

1996-2001 Total 600,000,000 JPY (about 5 million USD)

Solution Oriented Research for Science and Technology (SORST, JST)

15,000,000 JPY (about 120,000 USD)

70,000,000 JPY (about 500,000 USD)

50 Select Publications

1. Kimura H, Kasahara Y, Kurosu K, Sugito K, Takiguchi Y, Terai M, Mikata A, Natsume M, Mukaida N, Matsushima K, Kuriyama T. Alleviation of monocrotaline-induced pulmonary hypertension by antibodies to monocyte chemotactic and activating factor/monocyte chemoattractant protein-1. *Lab Invest.* 1998;78:571-581
2. Kuno K, Matsushima K. ADAMTS-1 protein anchors at the extracellular matrix through the thrombospondin type I motifs and its spacing region. *J Biol Chem.* 1998;273:13912-13917
3. Sonoda Y, Mukaida N, Wang JB, Shimada-Hiratsuka M, Naito M, Kasahara T, Harada A, Inoue M, Matsushima K. Physiologic regulation of postovulatory neutrophil migration into vagina in mice by a C-X-C chemokine(s). *J Immunol.* 1998;160:6159-6165
4. Tachibana K, Hirota S, Iizasa H, Yoshida H, Kawabata K, Kataoka Y, Kitamura Y, Matsushima K, Yoshida N, Nishikawa S, Kishimoto T, Nagasawa T. The chemokine receptor CXCR4 is essential for vascularization of the gastrointestinal tract. *Nature.* 1998;393:591-594
5. Wang J, Harada A, Matsushita S, Matsumi S, Zhang Y, Shioda T, Nagai Y, Matsushima K. IL-4 and a glucocorticoid up-regulate CXCR4 expression on human CD4+ T lymphocytes and enhance HIV-1 replication. *J Leukoc Biol.* 1998;64:642-649
6. Yoneyama H, Harada A, Imai T, Baba M, Yoshie O, Zhang Y, Higashi H, Murai M, Asakura H, Matsushima K. Pivotal role of TARC, a CC chemokine, in bacteria-induced fulminant hepatic failure in mice. *J Clin Invest.* 1998;102:1933-1941
7. Zhang Y, Harada A, Wang JB, Zhang YY, Hashimoto S, Naito M, Matsushima K. Bifurcated dendritic cell differentiation in vitro from murine lineage phenotype-negative c-kit+ bone marrow hematopoietic progenitor cells. *Blood.* 1998;92:118-128
8. Hashimoto S, Suzuki T, Dong HY, Nagai S, Yamazaki N, Matsushima K. Serial analysis of gene expression in human monocyte-derived dendritic cells. *Blood.* 1999;94:845-852
9. Hashimoto S, Suzuki T, Dong HY, Yamazaki N, Matsushima K. Serial analysis of gene expression in human monocytes and macrophages. *Blood.* 1999;94:837-844
10. Imai T, Nagira M, Takagi S, Kakizaki M, Nishimura M, Wang J, Gray PW, Matsushima K, Yoshie O. Selective recruitment of CCR4-bearing Th2 cells toward antigen-presenting cells by the CC

- chemokines thymus and activation-regulated chemokine and macrophage-derived chemokine. *Int Immunol.* 1999;11:81-88
11. Kuno K, Terashima Y, Matsushima K. ADAMTS-1 is an active metalloproteinase associated with the extracellular matrix. *J Biol Chem.* 1999;274:18821-18826
 12. Murai M, Yoneyama H, Harada A, Yi Z, Vestergaard C, Guo B, Suzuki K, Asakura H, Matsushima K. Active participation of CCR5(+)CD8(+) T lymphocytes in the pathogenesis of liver injury in graft-versus-host disease. *J Clin Invest.* 1999;104:49-57
 13. Ogata M, Zhang Y, Wang Y, Itakura M, Zhang YY, Harada A, Hashimoto S, Matsushima K. Chemotactic response toward chemokines and its regulation by transforming growth factor-beta1 of murine bone marrow hematopoietic progenitor cell-derived different subset of dendritic cells. *Blood.* 1999;93:3225-3232
 14. Tsuji H, Mukaida N, Harada A, Kaneko S, Matsushita E, Nakanuma Y, Tsutsui H, Okamura H, Nakanishi K, Tagawa Y, Iwakura Y, Kobayashi K, Matsushima K. Alleviation of lipopolysaccharide-induced acute liver injury in Propionibacterium acnes-primed IFN-gamma-deficient mice by a concomitant reduction of TNF-alpha, IL-12, and IL-18 production. *J Immunol.* 1999;162:1049-1055
 15. Vestergaard C, Yoneyama H, Murai M, Nakamura K, Tamaki K, Terashima Y, Imai T, Yoshie O, Irimura T, Mizutani H, Matsushima K. Overproduction of Th2-specific chemokines in NC/Nga mice exhibiting atopic dermatitis-like lesions. *J Clin Invest.* 1999;104:1097-1105
 16. Zhang Y, Zhang YY, Ogata M, Chen P, Harada A, Hashimoto S, Matsushima K. Transforming growth factor-beta1 polarizes murine hematopoietic progenitor cells to generate Langerhans cell-like dendritic cells through a monocyte/macrophage differentiation pathway. *Blood.* 1999;93:1208-1220
 17. Hashimoto SI, Suzuki T, Nagai S, Yamashita T, Toyoda N, Matsushima K. Identification of genes specifically expressed in human activated and mature dendritic cells through serial analysis of gene expression. *Blood.* 2000;96:2206-2214.
 18. Inadera H, Sekiya T, Yoshimura T, Matsushima K. Molecular analysis of the inhibition of monocyte chemoattractant protein-1 gene expression by estrogens and xenoestrogens in MCF-7 cells. *Endocrinology.* 2000;141:50-59
 19. Onai N, Zhang Y, Yoneyama H, Kitamura T, Ishikawa S, Matsushima K. Impairment of lymphopoiesis and myelopoiesis in mice reconstituted with bone marrow-hematopoietic progenitor cells expressing SDF-1-intrakine. *Blood.* 2000;96:2074-2080.
 20. Sekiya T, Miyamasu M, Imanishi M, Yamada H, Nakajima T, Yamaguchi M, Fujisawa T, Pawankar R, Sano Y, Ohta K, Ishii A, Morita Y, Yamamoto K, Matsushima K, Yoshie O, Hirai K. Inducible expression of a Th2-type CC chemokine thymus- and activation-regulated chemokine by human bronchial epithelial cells. *J Immunol.* 2000;165:2205-2213
 21. Shindo T, Kurihara H, Kuno K, Yokoyama H, Wada T, Kurihara Y, Imai T, Wang Y, Ogata M, Nishimatsu H, Moriyama N, Oh-hashii Y, Morita H, Ishikawa T, Nagai R, Yazaki Y, Matsushima K. ADAMTS-1: a metalloproteinase-disintegrin essential for normal growth, fertility, and organ morphology and function. *J Clin Invest.* 2000;105:1345-1352.
 22. Suzuki T, Hashimoto S, Toyoda N, Nagai S, Yamazaki N, Dong HY, Sakai J, Yamashita T, Nukiwa T, Matsushima K. Comprehensive gene expression profile of LPS-stimulated human monocytes by SAGE. *Blood.* 2000;96:2584-2591
 23. Tokuda A, Itakura M, Onai N, Kimura H, Kuriyama T, Matsushima K. Pivotal role of CCR1-positive leukocytes in bleomycin-induced lung fibrosis in mice. *J Immunol.* 2000;164:2745-2751
 24. Vestergaard C, Bang K, Gesser B, Yoneyama H, Matsushima K, Larsen CG. A Th2 Chemokine, TARC, Produced by Keratinocytes May Recruit CLA+CCR4+ Lymphocytes into Lesional Atopic Dermatitis Skin. *J Invest Dermatol.* 2000;115:640-646
 25. Wada T, Furuichi K, Sakai N, Iwata Y, Yoshimoto K, Shimizu M, Takeda SI, Takasawa K, Yoshimura M, Kida H, Kobayashi KI, Mukaida N, Naito T, Matsushima K, Yokoyama H. Up-regulation of monocyte chemoattractant protein-1 in tubulointerstitial lesions of human diabetic nephropathy. *Kidney Int.* 2000;58:1492-1499
 26. Wada T, Furuichi K, Sakai N, Iwata Y, Yoshimoto K, Shimizu M, Kobayashi K, Mukaida N, Matsushima K, Yokoyama H. A new anti-inflammatory compound, FR167653, ameliorates crescentic glomerulonephritis in Wistar-Kyoto rats. *J Am Soc Nephrol.* 2000;11:1534-1541
 27. Yamamoto J, Adachi Y, Onoue Y, Adachi YS, Okabe Y, Itazawa T, Toyoda M, Seki T, Morohashi M, Matsushima K, Miyawaki T. Differential expression of the chemokine receptors by the Th1- and Th2-type effector populations within circulating CD4+ T cells. *J Leukoc Biol.* 2000;68:568-574.
 28. Zhang Y, Wang Y, Ogata M, Hashimoto S, Onai N, Matsushima K. Development of dendritic cells in vitro from murine fetal liver-derived lineage phenotype-negative c-kit(+) hematopoietic progenitor cells. *Blood.* 2000;95:138-146
 29. Furuichi K, Wada T, Iwata Y, Sakai N, Yoshimoto K, Shimizu M, Kobayashi K, Takasawa K, Kida H, Takeda S, Matsushima K, Yokoyama H. Upregulation of fractalkine in human crescentic glomerulonephritis. *Nephron.* 2001;87:314-320.
 30. Ishikawa S, Sato T, Abe M, Nagai S, Onai N, Yoneyama H, Zhang Y, Suzuki T, Hashimoto S, Shirai T, Lipp M, Matsushima K. Aberrant high expression of B lymphocyte chemokine (BLC/CXCL13) by C11b+CD11c+ dendritic cells in murine lupus and preferential chemotaxis of B1 cells towards BLC. *J Exp Med.* 2001;193:1393-1402.

31. Itakura M, Tokuda A, Kimura H, Nagai S, Yoneyama H, Onai N, Ishikawa S, Kuriyama T, Matsushima K. Blockade of secondary lymphoid tissue chemokine exacerbates *Propionibacterium acnes*-induced acute lung inflammation. *J Immunol.* 2001;166:2071-2079.
32. Kawasaki S, Takizawa H, Yoneyama H, Nakayama T, Fujisawa R, Izumizaki M, Imai T, Yoshie O, Homma I, Yamamoto K, Matsushima K. Intervention of thymus and activation-regulated chemokine attenuates the development of allergic airway inflammation and hyperresponsiveness in mice. *J Immunol.* 2001;166:2055-2062.
33. Takayama T, Morelli AE, Onai N, Hirao M, Matsushima K, Tahara H, Thomson AW. Mammalian and viral IL-10 enhance C-C chemokine receptor 5 but down-regulate C-C chemokine receptor 7 expression by myeloid dendritic cells: impact on chemotactic responses and in vivo homing ability. *J Immunol.* 2001;166:7136-7143.
34. Wada T, Furuichi K, Sakai N, Hisada Y, Kobayashi K, Mukaida N, Tomosugi N, Matsushima K, Yokoyama H. Involvement of p38 mitogen-activated protein kinase followed by chemokine expression in crescentic glomerulonephritis. *Am J Kidney Dis.* 2001;38:1169-1177.
35. Yamashita T, Kaneko S, Hashimoto S, Sato T, Nagai S, Toyoda N, Suzuki T, Kobayashi K, Matsushima K. Serial analysis of gene expression in chronic hepatitis C and hepatocellular carcinoma. *Biochem Biophys Res Commun.* 2001;282:647-654.
36. Yokochi S, Hashimoto H, Ishiwata Y, Shimokawa H, Haino M, Terashima Y, Matsushima K. An anti-inflammatory drug, propagermanium, may target GPI-anchored proteins associated with an MCP-1 receptor, CCR2. *J Interferon Cytokine Res.* 2001;21:389-398.
37. Yoneyama H, Matsuno K, Zhang Y, Murai M, Itakura M, Ishikawa S, Hasegawa G, Naito M, Asakura H, Matsushima K. Regulation by chemokines of circulating dendritic cell precursors, and the formation of portal tract-associated lymphoid tissue, in a granulomatous liver disease. *J Exp Med.* 2001;193:35-49.
38. Higashi N, Fujioka K, Denda-Nagai K, Hashimoto S, Nagai S, Sato T, Fujita Y, Morikawa A, Tsuiji M, Miyata-Takeuchi M, Sano Y, Suzuki N, Yamamoto K, Matsushima K, Irimura T. The macrophage C-type lectin specific for galactose/N-acetylgalactosamine is an endocytic receptor expressed on monocyte-derived immature dendritic cells. *J Biol Chem.* 2002;277:20686-20693.
39. Inadera H, Dong HY, Matsushima K. WISP-2 is a secreted protein and can be a marker of estrogen exposure in MCF-7 cells. *Biochem Biophys Res Commun.* 2002;294:602-608.
40. Ishikawa S, Nagai S, Sato T, Akadegawa K, Yoneyama H, Zhang YY, Onai N, Matsushima K. Increased circulating CD11b⁺CD11c⁺ dendritic cells (DC) in aged BWF1 mice which can be matured by TNF- α into BLC/CXCL13-producing DC. *Eur J Immunol.* 2002;32:1881-1887.
41. Kuno K, Baba C, Asaka A, Matsushima C, Matsushima K, Hosono R. The Caenorhabditis elegans ADAMTS family gene *adt-1* is necessary for morphogenesis of the male copulatory organs. *J Biol Chem.* 2002;277:12228-12236.
42. Kurachi M, Hashimoto S, Obata A, Nagai S, Nagahata T, Inadera H, Sone H, Tohyama C, Kaneko S, Kobayashi K, Matsushima K. Identification of 2,3,7,8-tetrachlorodibenzo-p-dioxin-responsive genes in mouse liver by serial analysis of gene expression. *Biochem Biophys Res Commun.* 2002;292:368-377.
43. Narumi S, Kaburaki T, Yoneyama H, Iwamura H, Kobayashi Y, Matsushima K. Neutralization of IFN-inducible protein 10/CXCL10 exacerbates experimental autoimmune encephalomyelitis. *Eur J Immunol.* 2002;32:1784-1791.
44. Onai N, Kitabatake M, Zhang YY, Ishikawa H, Ishikawa S, Matsushima K. Pivotal role of CCL25 (TECK)-CCR9 in the formation of gut cryptopatches and consequent appearance of intestinal intraepithelial T lymphocytes. *Int Immunol.* 2002;14:687-694.
45. Sekiya T, Yamada H, Yamaguchi M, Yamamoto K, Ishii A, Yoshie O, Sano Y, Morita A, Matsushima K, Hirai K. Increased levels of a TH2-type CC chemokine thymus and activation-regulated chemokine (TARC) in serum and induced sputum of asthmatics. *Allergy.* 2002;57:173-177.
46. Uekusa Y, Yu WG, Mukai T, Gao P, Yamaguchi N, Murai M, Matsushima K, Obika S, Imanishi T, Higashibata Y, Nomura S, Kitamura Y, Fujiwara H, Hamaoka T. A pivotal role for CC chemokine receptor 5 in T-cell migration to tumor sites induced by interleukin 12 treatment in tumor-bearing mice. *Cancer Res.* 2002;62:3751-3758.
47. Ueno T, Hara K, Willis MS, Malin MA, Hopken UE, Gray DH, Matsushima K, Lipp M, Springer TA, Boyd RL, Yoshie O, Takahama Y. Role for CCR7 ligands in the emigration of newly generated T lymphocytes from the neonatal thymus. *Immunity.* 2002;16:205-218.
48. Wang Y, Zhang Y, Yoneyama H, Onai N, Sato T, Matsushima K. Identification of CD8 α (⁺)CD11c(⁻) lineage phenotype-negative cells in the spleen as committed precursor of CD8 α (⁺) dendritic cells. *Blood.* 2002;100:569-577.
49. Yoneyama H, Narumi S, Zhang Y, Murai M, Baggioolini M, Lanzavecchia A, Ichida T, Asakura H, Matsushima K. Pivotal role of dendritic cell-derived CXCL10 in the retention of T helper cell 1 lymphocytes in secondary lymph nodes. *J Exp Med.* 2002;195:1257-1266.
50. Yoshie O, Fujisawa R, Nakayama T, Harasawa H, Tago H, Izawa D, Hieshima K, Tatsumi Y, Matsushima K, Hasegawa H, Kanamaru A, Kamihira S, Yamada Y. Frequent expression of CCR4 in adult T-cell leukemia and human T-cell leukemia virus type 1-transformed T cells. *Blood.* 2002;99:1505-1511.

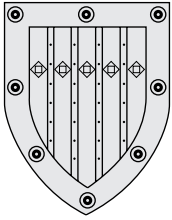

Department of Public Health

Outline and Research Objectives

Public health departments in medical schools in Japan were introduced after the World War II, following the model of the U.S. system of medical education. The Department of Public Health was established in 1948, in the Faculty of Medicine, University of Tokyo. In 1995, the Department became a part of the Division of Social Medicine, Graduate School of Medicine, as the result of the shift to a graduate school system in University of Tokyo.

The objectives of the Department are both education and research of public health. The Department trains graduate and undergraduate students through lectures, seminars, field practice, and laboratory work in public health and occupational medicine, for the degrees of Medical Doctor (MD), Master of Medical Sciences (MSc), and Doctor of Medical Sciences (DMSc). The Department also provides those lectures related to public health and occupational medicine for undergraduate students in the School of Health Sciences and Nursing.

The Department has conducted research on a wide variety of public health issues, including health policy and economics, occupational medicine, environmental health, community and clinical epidemiology, behavioral medicine, and so on. In addition, the staff members of the Department have offered public and occupational health services to the central and local governments, industries, and local communities.

Currently, the Department comprises a professor and chair, an associate professor, a lecturer, an associate, a research resident, several part-time lecturers, and several visiting research fellows, all of who take part in the education and/or the research of the Department.

Faculties and Students:

Professor and Chair	Yasuki Kobayashi, MD, DMSc (since April 2001)
Associate Professor	Kazuhito Yokoyama, MD, DMSc
Lecturer	Hajime Sato, MD, MPH, DMSc, DPH
Associate	1
Research Resident	1
Postdoctoral Fellow	1
Graduate Students	10 (including 3 entrusted students)
Research Students	4
Secretary	2

Past Research and Major Accomplishments

1) Health policy and economics

We are interested in the topics of health care system and economics in general. We have performed and published those studies related to supply and demand sides of health services in Japan; such as supply and distribution of physicians, the separation of pharmaceutical dispensing and prescribing in medical practice, cost studies of outpatient and inpatient services, and the efficiency and equity of the Japan's health insurance system.

For the issues of physician supply, we examined

and analyzed the impact of physician manpower policy in the 1970s and 1980s in Japan, through both economic and statistical methods, and showed that geographic mal-distribution of physicians did not improve despite the growing number of physician during the period. Also, we projected future demand of physicians by specialty in Japan, since this issue brought a constant debate among the government, medical schools, medical providers, and patients. Our projections could facilitate these arguments.

For Japan's insurance system, we first showed that it would be cost-beneficial if an electronic claiming system were introduced to the system. On the other hand, the financing system for the elderly health care is really a global issue worldwide, and we also have tackled the issue. Since the late 1980s, we have shown the effectiveness and efficiency of home care for the elderly in terms of their quality of life. In the late 1990s, there have been wide and continuous debates on the matter nationwide, and finally the new insurance system, namely the Long-term Care Insurance for the Elderly has been introduced to Japan since the year 2000. Our study results have definitely facilitated these discussions.

We have examined what factors are relevant to early discharge of elderly patients. We did a follow-up survey of hospitalized patients with cerebrovascular

diseases (CVD) in almost all the hospitals in a prefecture. The study showed that the caregiver's conditions, including economic ones, as well as the patient's conditions, were closely related to earlier home discharge of the CVD patients.

We have carried on several policy studies in the health and environmental fields, especially those from international comparative perspectives, such as tobacco smoking control, and patient isolation policy for Hansen's disease. These studies have been published in some international policy journals.

Overall, we have contributed to the evidence based health policy in Japan, through numerous empirical studies using the methods of epidemiology and health economics.

2) Occupational medicine and environmental health

We have tackled the issues of neurotoxicologic effects of lead and other heavy metals and solvents, sarin poisoning, particulate matter monitoring, and health effects of pesticides in developing countries as part of the Alliance for Global Sustainability project. We have been also interested in the issues of behavioral medicine, such as socioeconomic and psychological aspects of drinking and traffic accidents. For the above purposes, the Department conducted international collaborative studies in the Faeroes islands of Denmark (methyl-mercury), Seoul of Korea (lead, chromium and mercury poisonings) and Kota Bahr of Malaysia (pesticide poisoning). Also, the former chairman of the Department (Araki), as Chairman of the Scientific Committee on Neurotoxicology and Psychophysiology of the International Commission on Occupational Health (ICOH), promoted symposia at the ICOH 2000 Congress in Singapore. The Department also held the 48th Annual Meeting of the Japanese Society of Occupational Medicine and Traumatology in Tokyo in November 2000.

3) Community and clinical epidemiology

We have done several epidemiological studies in community, occupational, or clinical settings, such as active life expectancy for the elderly, quality of life assessment in RA patients, work-related diseases, and outcome studies for various kinds of treatments. Most of these studies have been carried on in collaboration with local communities, industries, or clinical departments, and published in various journals.

Current Research

Most of the above mentioned research topics are tackled at present, with new perspectives and methodologies. For the insurance system, recently the separation of prescribing and dispensing of pharma-

ceuticals has progressed, however, our study has suggested that the separation itself would not necessarily lead to the cost containment of pharmaceuticals because physicians tend to prescribe brand-name pharmaceuticals. Therefore, we suggest that such a separation policy should be combined with a policy encouraging the use of generics.

In addition, we study the methods and guidelines by which health insurance claim data will be used for research with securing the patients' privacy. Such a study would facilitate expanding the volume of and improving the quality of health services research in Japan, consequently lead to the improvement of quality of health services in Japan.

For the issues of the financing system worldwide, we have recently begun to study a system for providing the effective treatment for people with HIV/AIDS in developing countries, since the issue is a global and urgent one both in terms of health and economics. We have conducted a cost study of providing highly active antiretroviral therapy (HAART) to AIDS patients in Khon Kaen Province, Thailand. As a result, we indicate that a substantial increase of resources would be necessary to provide HAART to all the adult AIDS patients under the current universal coverage system in Khon Kaen province, and we suggest possible solutions for this financial obstacle. This type of analysis would be also useful to assess the financial implications of providing HAART for public health systems worldwide.

For the issues of environmental pollution and health effects of chemicals, we have recently started an international collaborative study on pesticide problem in Malaysia. In the study, the health effects of pesticide in relation to occupational safety behavior are studied among tobacco-growing farmers in Kelantan, Malaysia. So far, the following results are obtained; (i) Organophosphate and dithiocarbamate pesticides affect peripheral nerve conduction, whereas pyrethroid affects postural balance system. (ii) Nonsmoking while spraying, good-sprayer condition, and changing clothes immediately after spraying prevents occurrence of acute symptoms just after pesticide spray in male farmers; in female farmers, wearing a hat while spraying significantly prevents the symptoms. These results suggest that sub-clinical health effects are caused by pesticide use; the effects could be prevented by safety handling of pesticides so that health education would be effective.

Future Prospects

Our empirical studies on the health insurance system and health manpower policy in Japan are unique, and our strength. Therefore, we should continue to expand these kinds of studies and to train profession-

als in such fields, and hope to facilitate and contribute to improving our health care system. Furthermore, international collaborative studies for public health are also a tradition of the Department as well as its strength in terms of research. We would also like to continue such collaborative studies on health of and health care for disadvantaged people, such as the poor, the frail elderly, people with HIV/AIDS, and underprivileged workers. In addition, since there are growing needs for epidemiological studies in occupational and clinical settings, we should expand outcome studies and clinical epidemiology, in collaboration with clinical departments. In order to maintain and promote health for all the people in Japan and in the world, it is essential to promote both theoretical and empirical studies in public health. The Department is making every effort for this purpose through domestic, international and interdisciplinary collaborative researches.

Research Grants

1. 2001-03 Research Grants from Ministry of Education, Culture, and Sports. Study on payment system for the checking functions preventing adverse events of pharmaceuticals in the separation of prescribing and dispensing. (Kobayashi Y)
2. 2001-03 Health Sciences Research Grants (Research on Policy Planning and Evaluation) from the Ministry of Health, Labor and Welfare of Japan. Study on use and security of insurance claim data in Japan's health insurance system. (Kobayashi Y)
3. 2001-04 Grant for Health Cooperation Research from the Ministry of Health, Labor and Welfare of Japan. Study on a financing system for providing the effective treatment for people with HIV/AIDS in developing countries. (Kobayashi Y)
4. 2001-03 Research Grants from Ministry of Education, Culture, and Sports. Study on risk assessment of subclinical neuro-behavioral effects of environmental pollutants. (Yokoyama K)
5. 2001-04 Research Grants from Ministry of Education, Culture, and Sports. International collaborative study on health effects of pesticides and their safe use. (Yokoyama K)
- 3 Kobayashi Y, Reich MR. Health care financing for the elderly in Japan. *Social Science & Medicine* 37: 343-353, 1993.
- 4 Kobayashi Y, Chiba Y, Hikita K, Kusumoto K. Collaboration between Japan and China towards poliomyelitis eradication [letter]. *Lancet* 1995; 345: 455.
- 5 Tamiya, N., Araki, S., Kobayashi, Y., Yamashita, K., Murata, K., Yano, E.: Gender difference in the utilization and use's characteristics of community rehabilitation programs for cerebrovascular disease patients in Japan. *International Journal for Quality in Health Care* 8: 359-366, 1996.
- 6 Ishizaki T, Kobayashi Y, Tamiya N. The role of geriatric intermediate care facilities in long-term care for the elderly in Japan. *Health Policy* 43:141-151, 1998.
- 7 Sato, H.: Policy and politics of smoking control in Japan. *Social Science & Medicine* 49: 581-600, 1999.
- 8 Sato, H.: The advocacy coalition framework and the policy process analysis: The case of smoking control in Japan. *Policy Studies Journal* 27: 28-44, 1999.
- 9 Sato, H., Araki, S.: Yields and daily consumption of cigarettes in Japan in 1969-1996. *Journal of Epidemiology* 10: 7-15, 2000.
- 10 Sato, H., Araki, S., Yokoyama, K.: Policy functions of smoking control in Japan: Government and social interests in smoking control in Japan. *Environmental Health and Preventive Medicine* 4 : 156-164, 2000.
- 11 Voorhees, A.S., Araki, S., Sakai, R., Sato, H.: An ex post cost-benefit analysis of the nitrogen dioxide air pollution control program in Tokyo. *Journal of the Air & Waste Management Association* 50: 391-410, 2000.
- 12 Sato, H., Araki, S., Yokoyama, K.: Influence of monopoly privatization and market liberalization on smoking prevalence in Japan: Trends of smoking prevalence in Japan in 1975-1995. *Addiction* 95: 1089-1098, 2000.
- 13 Voorhees, A. S., Sakai, R., Araki, S., Sato, H., Otsu, A.: Cost benefits analysis of nitrogen dioxide control programmes: A case study of Chiyoda-ku, Tokyo. *Journal of Environmental Planning and Management* 44 : 149-165, 2001.
- 14 Asano, N., Kobayashi, Y., Kano, K.: Issues of interventions aimed at preventing prospective surplus of physicians in Japan. *Medical Education* 35: 488-494, 2001.
- 15 Tamiya, N., Kobayashi, Y., Murakami, S., Sasaki, J., Yoshizawa, K., Otaki, J., Kano, K.: Factors related to home discharge of cerebrovascular disease patients, one-year follow-up interview survey of caregivers of hospitalized patients in 53 acute care hospitals in Japan. *Archives of Gerontology and Geriatrics* 33: 109-121, 2001.

Select Publications

Health policy and economics

- 1 Kobayashi Y, Yano E. Structure, process, effectiveness and efficiency of the check and review system in Japan's health insurance. *Health Policy* 19: 229-244, 1991.
- 2 Kobayashi Y, Takaki H. Geographic distribution of physicians in Japan. *Lancet* 340: 1391-1393, 1992.

(2) Occupational medicine and environmental health

- 16 Hayashi T, Kobayashi Y, Yamaoka K, Yano E. Effect of overtime work on 24-hour ambulatory blood pres-

- sure. *Journal of Occupational and Environmental Medicine* 38: 1007-1011, 1996.
- 17 Tanigawa, T., Araki, S., Nakata, A., Araki, T., Sakurai, S.: Decreases in subpopulations of T lymphocytes and natural killer cells in the blood of retired chromate workers. *International Journal of Occupational and Environmental Health* 2: 222-225, 1996.
 - 18 Sata, F., Araki, S.: Adjustment of creatinine-adjusted value to urine flow rate in lead workers. *Archives of Environmental Health* 51: 329-333, 1996.
 - 19 Kawakami, N., Araki, S., Kawashima, M., Masumoto, T., Hayashi, T.: Effects of work-related stress reduction on depressive symptoms among Japanese blue-collar workers. *Scandinavian Journal of Work, Environment Health* 23: 54-59, 1997.
 - 20 Yokoyama, K., Araki, S., Murata, K., Morita, Y., Katsuno, N., Tanigawa, T., Mori, N., Yokota, J., Ito, A., Sakata, E.: Subclinical vestibulo-cerebellar, anterior cerebellar lobe and spinocerebellar effects in lead workers in relation to concurrent and past exposure. *Neurotoxicology* 18: 371-380, 1997.
 - 21 Yokoyama, K., Araki, S., Murata, K., Nishikitani, M., Nakaaki, K., Yokota, J., Ito, A., Sakata, E.: Postural sway frequency analysis in workers exposed to n-hexane, xylene, and toluene: Assessment of subclinical cerebellar dysfunction. *Environmental Research* 74: 110-115, 1997.
 - 22 Sata, F., Araki, S., Sakai, T., Nakata, A., Yamashita, K., Morita, Y., Tanigawa, T., Miki, A.: Immunological effects of CaEDTA injection: Observations in two lead workers. *American Journal of Industrial Medicine* 32: 674-680, 1997.
 - 23 Grandjean, P., Weihe, P., White, R.F., Debes, F., Araki, S., Yokoyama, K., Murata, K., Sérgensen, N., Dahl, R., Jérgensen, P.J.: Cognitive deficit in 7-year-old children with prenatal exposure to methylmercury. *Neurotoxicology and Teratology* 19: 417-428, 1997.
 - 24 Murata, K., Araki, S., Yokoyama, K., Okumura, T., Ishimatsu, S., Takasu, N., White, R.F.: Asymptomatic sequelae to acute sarin poisoning in the central and autonomic nervous system 6 months after the Tokyo subway attack. *Journal of Neurology* 244: 601-606, 1997.
 - 25 Yokoyama, K., Araki, S., Murata, K., Nishikitani, M., Okumura, T., Ishimatsu, S., Takasu, N.: A preliminary study on delayed vestibulo-cerebellar effects of Tokyo subway sarin poisoning in relation to gender difference: Frequency analysis of postural sway. *Journal of Occupational and Environmental Medicine* 40:17-21, 1998.
 - 26 Yokoyama, K., Araki, S., Murata, K., Nishikitani, M., Okumura, T., Ishimatsu, S., Takasu, N., White, R.F.: Chronic neuro-behavioral effects of Tokyo subway sarin poisoning in relation to posttraumatic stress disorder. *Archives of Environmental Health* 53: 249-256, 1998.
 - 27 Yokoyama, K., Araki, S., Aono, H., Murata, K.: Calcium disodium ethylene-diaminetetraacetate-chelated lead as a predictor for subclinical lead neurotoxicity: Follow-up study on gun-metal foundry workers. *International Archives of Occupational and Environmental Health* 71: 459-464, 1998.
 - 28 Kim, J.M., Araki, S., Kim, D.J., Takasuka, N., Babatoriyama, H., Nir, Z., Khachik, F., Shimizu, N., Tanaka, Y., Osawa, T., Nishino, H., Tsuda, H.: Chemopreventive effects of carotenoids and curcumin on mouse colon carcinogenesis after 1,2-dimethylhydrazine initiation. *Carcinogenesis* 19: 81-85, 1998.
 - 29 Murata, K., Weihe, P., Renzoni, A., Debes, F., Vasconcelos, R., Zino, F., Araki, S., Jérgensen, P.J., White, R. F., Grandjean, P.: Delayed evoked potentials in children exposed to methylmercury from seafood. *Neurotoxicology and Teratology* 21: 343-348, 1999.
 - 30 Zhang, J., Araki, S., Sato, H., Yokoyama, K.: Psychobehavioral effects of divorced mother-headed one-child families on children in China. *Environmental Health and Preventive Medicine* 4: 135-139, 1999.
 - 31 Park, S.H., Araki, S., Nakata, A., Kim, Y.H., Park, J.A., Tanigawa, T., Yokoyama, K., Sato, H.: Effects of occupational metallic mercury vapor exposure on suppressor-inducer (CD4+CD45RA+) T lymphocytes and CD59+CD16+ natural killer cells. *International Archives of Occupational and Environmental Health* 73: 537-542, 2000.
 - 32 Kawakami, N., Akaki, K., Shimizu, H., Haratani, T., Kobayashi, F., Ishizaki, M., Hayashi, T., Fujita, O., Aizawa, Y., Miyazaki, S., Hiro, H., Hashimoto, S., Araki, S.: Job strain, social support in the workplace, and hemoglobin A1c in Japanese men. *Occupational and Environmental Medicine* 57: 805-809, 2000.
 - 33 Kitamura, F., Araki, S., Suzuki, Y., Yokoyama, K., Tanigawa, T., Iwasaki, R. : Assessment of the mutation of the p53 suppressor gene and Ha-and Ki-ras oncogenes in malignant mesothelioma in relation to asbestos exposure: A study of 12 American patients. *Industrial Health* 40: 175-181, 2002.
 - 34 Nordin, R., Araki, S., Sato, H., Yokoyama, K., Muda, W., Kyi, D. W.: Effects of safety behaviors of pesticide use on occurrence of acute symptoms in male and female tobacco-growing Malaysian farmers. *Industrial Health* 40: 182-190, 2002.
 - 35 Yokoyama, K., Araki, S., Yamashita, K., Murata, K., Nomiyama, K., Nomiyama, H., Tao, Y- X., Liu, S-J., Sato, H.: Subclinical cerebellar anterior lobe, vestibulo-cerebellar and spinocerebellar afferent effects in young female lead workers in China: Computerized posturography with sway frequency analysis and brainstem auditory evoked potentials. *Industrial Health* 40: 245-253, 2002.
- (3) Community and clinical epidemiology**
- 36 Kawakami, N., Iwata, N., Tanigawa, T., Ohga, H., Araki, S., Fujikihara, S., Kitamura, T.: Prevalence of mood and anxiety disorders in working population

- in Japan. *Journal of Occupational and Environmental Medicine* 38: 899-905, 1996.
- 37 Yamada, K., Araki, S., Tamura, M., Sakai, I., Takahashi, Y., Kashihara, H., Kono, S.: Case-control study of colorectal carcinoma in situ and cancer in relation to cigarette smoking and alcohol use in Japan. *Cancer Causes and Control* 8: 780-785, 1997.
 - 38 Yokoyama, K., Araki, S., Nishikitani, M.: Reasons for drinking in relation to problem drinking behavior in a sample of Japanese high school students. *International Journal of Behavioral Medicine* 6: 135-149, 1999.
 - 39 Kawakami, N., Araki, S., Takatsuka, N., Shimizu, H., Ishibashi, H.: Overtime, psychosocial working conditions, and occurrence of non-insulin dependent diabetes mellitus in Japanese men. *Journal of Epidemiology and Community Health* 53: 359-363, 1999.
 - 40 Yokoyama, K., Araki, S., Matsuoka, K., Mori, N., Sato, H., Nakao, M.: Socioeconomic factors affecting alcohol consumption in Japan. *Alcoholism* 35: 13-22, 1999.
 - 41 Hotta, Y., Araki, S., Sato, H., Yokoyama, K.: Social life factors for the mortality from motor vehicle accident. *Japanese Journal of Occupational Medicine and Traumatology* 48: 483-489, 2000.
 - 42 Ishizaki T, Kobayashi Y, Kai I. Functional transitions in instrumental activities of daily living among older Japanese. *Journal of Epidemiology* 10: 249-254, 2000.
 - 43 Suematsu, Y., Sato, H., Ohtsuka, T., Kotsuka, Y., Araki, S., Takamoto, S.: Predictive risk factors of delayed extubation in patients undergoing coronary bypass grafting. *Heart and Vessels* 15 : 214-220, 2000.
 - 44 Sato, H., Hashimoto, A., Araki, S., Nishibayashi, Y., Hoshi, K., Kutsuna, T., Shiino, Y., Ishihara, Y., Tsuboi, S., Fujimori, J., Kondo, H., Akizuki, M., Moroi, Y., Yoshida, S., Yokoyama, K.: Validity and reliability of a revised Japanese version of the arthritis impact measurement scales version 2 (AIMS2). *Modern Rheumatology* 10: 247-255, 2001.
 - 45 Shibata, K., Takamoto, S., Kotsuka, Y., Miyairi, T., Morota, T., Ueno, K., Sato, H.: Doppler ultrasonographic identification of the critical segmental artery for spinal cord protection. *European Journal of Cardio-Thoracic Surgery* 20 : 527-532, 2001.
 - 46 Lee JS, Kawakubo K, Sato H, Kobayashi Y, Haruna Y. Relationship between total and regional bone mineral density and menopausal state, body composition and life style factors in overweight Japanese women. *International Journal of Obesity* 25: 880-886, 2001.
 - 47 Lee JS, Kawakubo K, Kobayashi Y, Mori K, Kashihara H, Tamura M. Effects of ten year body weight variability on cardiovascular risk factors in Japanese middle-aged men and women. *International Journal of Obesity* 25: 1063-1067, 2001.
 - 48 Ishizaki T, Kai I, Kobayashi Y, Imanaka Y. Functional transitions and active life expectancy for older Japanese living in a community. *Archives of Gerontology and Geriatrics* 35: 107-120, 2002.
 - 49 Shibata, K., Takamoto, S., Kotsuka, Y., Sato, H.: Effectiveness of combined blood conservation measures in thoracic aortic operations under deep hypothermic circulatory arrest. *Annals of Thoracic Surgery* 73: 739-743, 2002.
 - 50 Ohyama T, Kobayashi Y, Mori K, Kano K, Sakurai K, Sato Y. Factors affecting complete resection of gastric tumors by the endoscopic mucosal resection procedure. *Journal of Gastroenterology and Hepatology* 17:844-848, 2002.

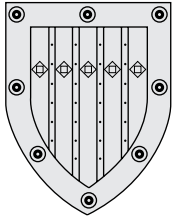

Department of Forensic Medicine

Outline and Research Objectives

Since Professor Kunika Katayama founded our department first in Japan on 1888, we have performed 10258 autopsies by September 30th, 2002. Our precursors have devoted to so many outstanding cases that were paid social attentions. Research objectives are blood-DNA typing, serology, toxicology, forensic pathology, etc. as described below.

Faculties and Students

Professor	Ken-ichi Yoshida, M.D (1999)
Associate Professor	Hirotaro Iwase, M.D. (2001)
Associate.....	2
Graduate students.....	6
Technical persons.....	4
Secretary	2

Past Research and Major Accomplishment

Besides the research on forensic pathology and determination of death cause, there have been outstanding accomplishments in basic medical field since Professor Mita, S., the founder of the Department of Immunology. Professor Furuhashi, T. was outstanding in the study on the inheritance of ABO blood group. Professor Ueno, S. discovered complements, while he studied on medical law. Professor Miki was famous for blood typing. Professor Ishiyama introduced DNA typing in the forensic practice, while encouraged forensic pathology. Professor Takatori, T. was famous in the autopsy and research on the Sarin murder cases, while his research on lipid has been inherited today.

Current Research

1) Reactive oxygen generation, and Lipid peroxidation and their implication in the pathogenesis:

We identified several lipid species that are generated in the presence of heme-proteins and associated with peroxidation. These lipids may be associated with the pathogenesis caused by oxidative stresses that are caused by ischemia-reperfusion (myocardial or brain infarction) or various drugs or toxins (amphetamines, carbon monoxide, agricultural medicines etc.). We undertake to clarify the molecular mechanism of the injury or the cell death due to these pathogens with reference to lipid peroxidation. Of these, 4-hydroxynonenal (HNE) is rapidly induced in the endothelium and sarcolemma of the infarcted

myocardium.

Carbon monoxide (CO) is the most common cause of death due to intoxication, and is often supposed to aggravate fatality due to ischemic heart diseases (IHD) or cause delayed neuronal death. CO protects cardiomyogenic cells against ischemia and alleviates reactive oxygen (ROS) generation. By contrast, in the *in vivo* experiments in the rat, CO plus hypoxia induces necrotic cortical neuronal death, which is associated with the enhanced production of lipid peroxide. Hypothermia reduced the neuronal injury and lipid peroxide generation, suggesting the implication of lipid peroxidation in the neuronal death induced by CO.

2) The molecular mechanism of the injury and cell death of myocardium or brain after ischemia-reperfusion or toxic substances.

More than two thirds of the causes of unusual death are ischemic heart or brain diseases. Most of such death occurs within an hour of the onset of the symptoms. Because it takes more than several hours from the onset of symptoms for the myocardium to show distinct histological changes (coagulation necrosis), it is mandatory to establish a diagnostic method for the early ischemia. To this end, we have to understand the molecular basis of the evolution of the ischemic heart or brain disease. We have clarified on the roles of proteases or intracellular signaling molecules in the pathogenesis of ischemic diseases and toxic cell injuries. 1) Brief ischemic (e.g. 10min) followed by reperfusion induces proteolysis of cytoskeletal proteins fodrin and ankyrin by Ca²⁺-dependent protease calpain, which causes contractile dysfunction in the isolated heart. This is the earliest irreversible change so far documented. 2) Protein Kinase C (PKC) isoforms translocate to membrane or nucleus during ischemia. Nitric oxide (NO) mediates the translocation of PKC- α , δ , and ϵ , which protects myocardium against reperfusion injury. 3) Ischemia-reperfusion causes sequential activation of PI3 kinase-PKC- ζ -MEK-MAP kinase- *c-fos*, thereby preventing apoptotic death. This study disclosed that MAP kinase translo-

cates to the nucleus independent of phosphorylation, but is activated by phosphorylation through MEK activation during postischemic reperfusion in the nucleus, in contrast with the paradigm. 4) Hypoxia under normoglycemia causes autophagic cell death through acidosis through PI3 kinase-mediated activation of glycolysis, explaining the myocardial death under pulmonary hypoventilation or hypoxic hypoxia. 5) Angina attacks often attenuate the injury due to subsequent myocardial infarction (MI). This phenomenon, ischemic preconditioning (IP), is reproduced in rat coronary occlusion model of acute MI. IP induces endothelial NO synthase (eNOS) and collateral vasodilation in the early MI, whereas IP induces angiogenesis in late MI through PKC- ϵ activation and Vascular Endothelium Growth Factor (VEGF) up-regulation. The both salvage myocardium in MI. 6) Connexin (Cx)-43 undergoes proteolysis during early MI through lysosomal and proteasomal proteases independently of calcineurin-mediated proteolysis. IP attenuates the Cx43 proteolysis in early MI. These findings explain the arrhythmias in early MI and its prevention by IP. 7) Emotional stress evoked by immobilization of rat causes activation of MAP kinase-*c-fos* pathway. 8) Methamphetamine (MAH) induces hyperthermia through sympathetico-adrenal activation and enhanced skeletal muscle metabolism, which is blocked by a sarcoplasmic reticulum Ca^{2+} -release blocker dantrolene. Repeated intermittent administration of MAH causes enhanced cardiovascular, thermal, and behavioral responses to MAH or emotional stress. We are willing to apply the findings of the experimental studies to exploit a new method for the diagnosis of ischemic or other disease states.

3) The study on the legal aspects of forensic medicine.

Forensic practices are associated with various legal or social problems that ought to be solved, though there have been research on such issues. On the other hand, those who provide expert opinion in the civil or legal litigation were far less than those required. There is dissociation in the thought-ways between medical doctors and lawyers, which can seriously violate the human right of persons concerned as well as causes the shortage of the expert witnesses. The courts have made effort to increase the numbers of expert witnesses for the litigation, though no adequate. On the other hand, the expression or the way of the expert witness may affect the judgment in the litigation or prosecution, as suggested by the questionnaire study.

The "reportable unusual deaths" in the guideline proposed by Japanese Society of Legal Medicine includes the unexpected death during or shortly after any medical practice. According to the Doctor's Act

in Japan, doctors must report unusual death cases to the police. The police (prosecutors) demand autopsy under the guidance of superintendents. In England, coroners request autopsy after inquiry with the police, relatives and forensic pathologists. Medical accidents are largely autopsied in England whereas, in Japan, medical accidents are rarely reported nor. In Tokyo and few other districts, medical examiners decide autopsy of 1/4~1/3 of unusual deaths, but autopsies in other districts are mostly conducted by police judgment in search for a possible crime. It should be reminded that death cause tells criminality and the responsibility only if the cause is diagnosed exactly by autopsy performed under proper judgment and that autopsy is often effective to clarify the cause of unexpected deaths. Recently in Japan, unexpected deaths in hospitals have come to be increasingly suspected as caused by malpractice. For lack of a proper system to answer for complaints from patients' side, the relatives sometimes go to the police. Though most cases are asked only for civil liability, the police investigate the hospital in question and this makes doctors hesitate to report. Prosecutors judge criminality on autopsy operator's expert opinion, whereas they insist that autopsy results should not be disclosed to protect privacy of investigation. Thus, an insufficient information on patient's side explains to a great extent why nearly 700 relatives sue doctors every year in Japan. In 2001, Japan Surgical Society announced to the public and Society of Legal Medicine that patients' death during or shortly after operations should not be accounted as an unusual death reportable to the police, but to the independent authority, if required. Though many cases are unavoidable and not problematic, doctors sometimes neither inform the patient's side enough to get satisfactory consent for the practice nor explain the necessity of autopsy to clarify death cause. As accepted in U.K., there should only be reasonable cause to suspect for "unusual death". Accordingly, although deaths in medical accident may be sometimes inevitable or unrelated to the malpractice, the doctor's explanation as such for an unexpected death can be hardly accepted by patient's side. Therefore, independent investigation and autopsy are required in medical accidents in order to determine and explain the cause of death to patient's side and to disclose and improve the medical practice by doctors. We are willing to devote to set up valid system for the death investigation in the medical accident cases.

4) Forensic pathology.

Because each case is unique and diversity is a important determinant of the death, we try to perform microscopic analyses in as many cases as possible. We undertake to take the advantage of the above-

mentioned studies in the immunohistochemical method for the diagnosis of our autopsy cases.

Future Prospective

The correct and fair determination of death cause in the medico-legal autopsy cases has been the most important mission of us. We must accept very difficult and socially notable victims and requirements of expert opinion. We must play this important role carefully and impatiently, and train young forensic pathologists.

There has been not so much evolution in the forensic practice except for the DNA identification technology. This may be the cause of the low overall activity in the forensic medicine. To open the window to the future of forensic medicine, we must do every effort to find new directions of forensic medicine and let them known to the public as well as medical field. Actually, there are many medico-legal issues in the clinical medicine, which have manifested as the growing criticisms from the society on the medical malpractice, inadequate risk management of the medical accidents, etc. In Japan, the death investigation system for the medical accidents and the unexpected death in hospitals is quite immature, so that it is very important and urgent to set up an independent organization for the death investigation for such cases. As forensic pathologists, we have autopsied such cases and recognize the problems to be addressed. We are going to take part in such activity in cooperation with clinicians and civil servants to find and build up the good system. Additionally, the education on these issues to the clinicians, citizens, as well as medical and law students are very important.

The legal systems for death investigation of "unusual death", prosecution and litigation have inherent drawbacks, which require improvement. We have taken effort to inform on the problems to persons concerned, but it is far from what is ought to be.

The 15~20% of total deaths are "unusual deaths", which requires death investigation. The misdiagnoses of the "unusual deaths" by clinicians, and police surgeons, are police officers have been manifested due to the inherent inadequacy of the system and poor education of those who investigate. Because there are some typical patterns of misdiagnoses and poor management of those cases, we must educate on these issues to students, medical service personnel, and the society.

Research Grant

Grant-in-aid from Monbusho (B) for Yoshida et al.

- 1) A survey for the myocardial proteins and genes induced by ischemia or psychological stress and its

application to the forensic practices (1998~1999) 10,200,000 yen

- 2) Identification and path-physiological study of novel peroxidized fatty acids formed in the tissue after ischemia or various intoxication and the exploitation of the new diagnostic method (2000~2001) 14,800,000 yen
- 3) Research on the mechanism of cellular injury due to nitric oxide or carbon monoxide in tissues undergoing ischemia or shock (2002) 14,000,000 yen

Grant-in-aid from Monbusho (C) for Uemura,

Yoshida et al.

- 4) Research on the intracellular stress response in the amphetamine-induced neuro-degeneration (1999~2000) 2,500,000 yen
- 5) Research on the molecular mechanism of promotion and protection of cell death by carbon monoxide (2002) 2,700,000 yen

Select Publications

1. Yoshida K, Inui M, Harada K, Saido TC, Sorimachi Y, Ishihara T, Kawashima S, Sobue K. Reperfusion of rat heart after brief ischemia induces proteolysis of caldesmon (nonerythroid spectrin or fodrin) by calpain. *Circ Res.* 77, 603-10, 1995.
2. Sorimachi Y, Harada K, Yoshida K. Involvement of calpain in postmortem proteolysis in the rat brain. *Forensic Sci Int.* 15, 81, 165-74.
3. Yoshida K, Hirata T, Akita Y, Mizukami Y, Yamaguchi K, Sorimachi Y, Ishihara T, Kawashima S. Translocation of protein kinase C- α , δ and ϵ isoforms in ischemic rat heart. *Biochim Biophys Acta.* 1996 Oct 7;1317(1):36-44.
4. Sorimachi Y, Harada K, Saido TC, Ono T, Kawashima S, Yoshida K. Downregulation of calpastatin in rat heart after brief ischemia and reperfusion. *J Biochem (Tokyo).* 1997 Oct;122(4):743-8.
5. Kitakaze M, Funaya H, Minamino T, Node K, Sato H, Ueda Y, Okuyama Y, Kuzuya T, Hori M, Yoshida K. Role of protein kinase C- α in activation of ecto-5' -nucleotidase in the preconditioned canine myocardium. *Biochem Biophys Res Commun* 1997 Oct 9;239(1):171-5
6. Fukuda S, Harada K, Kunimatsu M, Sakabe T, Yoshida K. Postischemic reperfusion induces α -fodrin proteolysis by m-calpain in the synaptosome and nucleus in rat brain. *J Neurochem.* 1998 Jun;70(6):2526-32.
7. Yoshida K, Harada K. Proteolysis of erythrocyte-type and brain-type ankyrins in rat heart after postischemic reperfusion. *J Biochem (Tokyo).* 1997 Aug;122(2):279-85.
8. Harada K, Fukuda S, Kunimoto M, Yoshida K. Distribution of ankyrin isoforms and their proteolysis after ischemia and reperfusion in rat brain. *J Neurochem.* 1997 Jul;69(1):371-6.
9. Harada K, Sorimachi Y, Yoshida K. Proteolysis of ankyrin and Na⁺/K⁺-ATPase in postmortem rat brain:

- is calpain involved? *Forensic Sci Int.* 1997 Apr 18;86(1-2):77-85.
10. Mizukami Y, Yoshioka K, Morimoto S, Yoshida K. A novel mechanism of JNK1 activation. Nuclear translocation and activation of JNK1 during ischemia and reperfusion. *J Biol Chem.* 1997 Jun 27;272(26):16657-62.
 11. Mizukami Y, Yoshida K. Mitogen-activated protein kinase translocates to the nucleus during ischaemia and is activated during reperfusion. *Biochem J.* 1997 May 1;323 (Pt 3):785-90.
 12. Mizukami Y, Hirata T, Yoshida K. Nuclear translocation of PKC zeta during ischemia and its inhibition by wortmannin, an inhibitor of phosphatidylinositol 3-kinase. *FEBS Lett.* 1997 Jan 20;401(2-3):247-51.
 13. Kawamura S, Yoshida K, Miura T, Mizukami Y, Matsuzaki M. Ischemic preconditioning translocates PKC-delta and -epsilon, which mediate functional protection in isolated rat heart. *Am J Physiol.* 1998 275(6 Pt 2):H2266-71.
 14. Kawata Y, Mizukami Y, Fujii Z, Sakumura T, Yoshida K, Matsuzaki M. Applied pressure enhances cell proliferation through mitogen-activated protein kinase activation in mesangial cells. *J Biol Chem.* 1998 Jul 3;273(27):16905-12.
 15. Makisumi T, Yoshida K, Watanabe T, Tan N, Murakami N, and Morimoto A. Sympatho-adrenal involvement in methamphetamine-induced hyperthermia through skeletal muscle hypermetabolism. *Eur J Pharmacol* 363, 107-112, 1998.
 16. Shama KMA, Suzuki A, Harada K, Fujitani N, Kimura H, Ohno S, Yoshida K. Transient up-regulation of myotonic dystrophy protein kinase-binding protein, MKBP, and HSP27 in the neonatal myocardium. *Cell Struct Funct* 1999; 24; 1-4.
 17. Yoshida K, Mizukami Y, Kitakaze M. Nitric oxide mediates protein kinase C isoform translocation in rat heart during postischemic reperfusion. *Biochim Biophys Acta* 1999; 1453; 230-8.
 18. Harada K, Ichiyama T, Ikeda H, Yoshida K. A fatal case of oral ingestion of benzene. *Am J Forensic Med Pathol* 1999; 20; 84-9.
 19. Harada K, Maekawa T, Shama KMA, Yamashita T, Yoshida K. Translocation and down-regulation of protein kinase C- α , - β , and - γ isoforms during ischemia-reperfusion in rat brain. *J Neurochem* 1999; 72; 2556-64.
 20. Yoshida K, Aki T, Harada K, Shama KMA, Kamoda Y, Suzuki A, Ohno S. Translocation of HSP27 and MKBP in ischemic heart. *Cell Struct Funct* 1999; 24; 181-5.
 21. Harada K, Asa K, Imachi T, Yamaguchi Y, Yoshida K. Centipede inflicted postmortem injury. *J Forensic Sci* 1999; 44; 849-50.
 22. Ueyama T, Yoshida K, Senba E. Emotional stress induces immediate-early gene expression in rat heart via activation of alpha- and beta-adrenoceptors. *Am J Physiol* 1999; 277; H1553-61.
 23. Sakurada K, Iwase H, Takatori T, Nagao M, Nakajima M, Niiijima H, Matsuda Y, Kobayashi M. Identification of cis-9,10-methylenehexadecanoic acid in submitochondrial particles of bovine heart. *Biochim Biophys Acta* 1999; 1437; 214-22.
 24. Niiijima H, Nagao M, Nakajima M, Takatori T, Matsuda Y, Iwase H, Kobayashi, M. Sarin-like, soman-like organophosphorous agents activate PLC gamma in rat brains. *Toxicol Appl Pharmacol* 1999; 156; 64-9.
 25. Kobayashi M, Takatori T, Nakajima M, Saka K, Iwase H, Nagao M, Niiijima H, Matsuda Y. Does the sequence of onset of rigor mortis depend on the proportion of muscle fiber types and on intra-muscular glycogen content? *Int J Legal Med* 1999; 112; 167-71
 26. Kobayashi M, Sakurada K, Nakajima M, Iwase H, Hatanaka K, Matsuda Y, Ikegaya H, Takatori T. A 'keyhole lesion' gunshot wound in an adipocere case. *Legal Med* 1999; 1; 170-3.
 27. Ikegaya H, Iwase H, Hatanaka K, Sakurada K, Matsuda Y, Kobayashi M, Takatori, T: Postmortem changes in cytochrome c oxidase activity in various organs of the rat and in human heart. *Forensic Sci Int* 108, 181-186, 2000
 28. Mizukami, Y, Kobayashi, S, Uberall, F, Hellbert, K, Kobayashi, N and Yoshida, K.: Nuclear mitogen-activated protein kinase activation by protein kinase C zeta during reoxygenation after ischemic hypoxia. *J Biol Chem*, 275, 19921-19927, 2000.
 29. Ueyama, T, Yoshida, K and Senba, E.: Stress-induced elevation of the ST segment in the rat electrocardiogram is normalized by an adrenoceptor blocker. *Clinical Exp Pharmacol Physiol*, 27, 384-386, 2000.
 30. Iwase, H., Sakurada, K., Hatanaka, K., Kobayashi, M. and Takatori, T.: Effect of cytochrome c on the linoleic acid-degrading activity of porcine leukocyte 12-lipoxygenase. *Free Radical Biol Med*, 28, 912-919, 2000.
 31. Nakajima, M., Nagao, M., Iwasa, M., Monma-Ohtaki, J., Maeno, Y., Koyama, H., Seko-Nakamura, Y., Isobe, I. and Takatori, T.: Related Articles : Purification and characterization of diquat (1, 1'-ethylene-2, 2'-dipyridylum)-metabolizing enzyme from paraquat-resistant rat liver cytosol. *Toxicology*, 154, 55-66, 2000.
 32. Shiraishi, K, Naito, K. and Yoshida, K. Inhibition of calpain but not caspase protects the testis against injury after experimental testicular torsion of rat. *Biol. Reproduct*, 63, 1538-1548, 2000.
 33. Tsuji T, Ohga Y, Yoshikawa Y, Sakata S, Abe T, Tabayashi N, Kobayashi S, Kohzuki H, Yoshida KI, Suga H, Kitamura S, Taniguchi S, Takaki M. Rat cardiac contractile dysfunction induced by Ca²⁺ overload: possible link to the proteolysis of alpha-fodrin. *Am J Physiol Heart Circ Physiol* 2001 281(3):H1286-9
 34. Uemura K, Harada K, Sadamitsu D, Tsuruta R, Takahashi M, Aki T, Yasuhara M, Maekawa T, Yoshida K. Apoptotic and necrotic brain lesions in a fatal case of carbon monoxide poisoning. *Forensic Sci Int* 2001; 116, 213-9.

35. Uemura K, Yoshida K. Seat belt induced transection of trachea in a child held on laps of adult upon car diving. *J Forensic Sci* 2001; 46: 714-6.
36. Sanada S, Kitakaze M, Papst PJ, Hatanaka K, Asanuma H, Aki T, Shinozaki Y, Ogita H, Node K, Takashima S, Asakura M, Yamada J, Fukushima T, Ogai A, Kuzuya T, Mori H, Terada N, Yoshida K, Hori M. Role of phasic dynamism of p38 mitogen-activated protein kinase activation in ischemic preconditioning of the canine heart. *Circ Res.* 2001 Feb 2;88(2):175-80.
37. Kawata H, Yoshida K, Kawamoto A, Kuroiwa H, Takase E, Sasaki Y, Hatanaka K, Kobayashi M, Ueyama T, Hashimoto T, Dohi K. Ischemic preconditioning upregulates vascular endothelial growth factor mRNA expression and neovascularization via nuclear translocation of protein kinase C ϵ in the rat ischemic myocardium. *Circ Res* 2001; 88: 696-704.
38. Hatanaka K, Ikegaya H, Takase I, Kobayashi M, Iwase H, Yoshida K. Immobilization stress-induced thymocyte apoptosis in rats. *Life Sci* 2001; 69: 155-65.
39. Ikegaya H, Iwase H, Hatanaka K, Sakurada K, Yoshida K, Takatori T. Diagnosis of cyanide intoxication by measurement of cytochrome c oxidase activity. *Toxicol Lett.* 2001; 119: 117-23.
40. Yamada Y, Kobayashi M, Takatori T, Nagao M, Ohira H, Yamamoto I, Ohtani S. Possibility of paternity testing using RFLP analysis of a very small amount of material. *J Forensic Odontostomatol* 2001; 19: 1-4.
41. Yamada Y, Takatori T, Nagao M, Iwase H, Kuroda N, Yanagida J, Shinozuka T. Expression of paraoxonase isoform did not confer protection from acute sarin poisoning in the Tokyo subway terrorist attack. *Int J Legal Med.* 2001; 115: 82-4.
42. Aki T, Mizukami Y, Oka Y, Yamaguchi Y, Uemura K, Fujimiya T, Yoshida K. Phosphoinositide 3-kinase accelerates necrotic cell death during hypoxia. *Biochem J* 2001; 358, 481-7.
43. Kudo R, Adachi J, Uemura K, Maekawa T, Ueno Y, Yoshida K. Lipid peroxidation in the rat brain after CO inhalation is temperature dependent. *Free Radical Biol Med* 2001; 31, 1417-23.
44. Iwase H, Kobayashi M, Nakajima M, Takatori T. The ratio of insulin to C-peptide can be used to make a forensic diagnosis of exogenous insulin overdose. *Forensic Sci Int* 2001; 115: 123-7.
45. Iwase H, Kobayashi M, Kurata A, Inoue S. Clinically unidentified dissection of vertebral artery as a cause of cerebellar infarction. *Stroke* 2001; 32: 1422-4.
46. Iwase H, Sakurada K, Ikegaya H, Hatanaka K, Takeichi H, Kobayashi M, Yoshida K. Thiol-oxidizing agent diamide and acidic pH enhance lipid peroxidation of rat heart mitochondria and cardiolipin-cytochrome c complex. *IUBMB Life* 2001; 51: 39-43.
47. Kobayashi M, Ikegaya H, Takase I, Hatanaka K, Sakurada K, Iwase H. Development of rigor mortis is not affected by muscle volume. *Forensic Sci Int* 2001; 117: 213-9.
48. Shiraishi K, Naito K, Yoshida K. Vasectomy impairs spermatogenesis through germ cell apoptosis mediated by p53-Bax pathway in the rat. *J Urology* 2001; 166: 1565-1568.
49. Shiraishi K, Yoshida K, Fujimiya T, Naito K. Activation of mitogen activated protein kinases and apoptosis of germ cells after vasectomy in the rat. *J Urology* 2002; 168: 1273-1278.
50. Yoshida K, Kuroki H, Takeichi H, Kawai K. Death during surgery in Japan. *The Lancet* 2002; 360: 805.

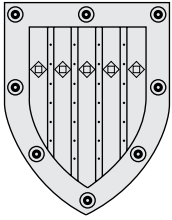

Department of Medical Informatics and Economics

Outline and Research Objectives

In 1983, the Department of Hospital Information Management(Hospital Computer Center) was established as one of central facilities in the University of Tokyo Hospital. The major roles have been designing, implementing, and maintaining the hospital information management system based on up-to-date information technology and improving functions of clinical information management required in the university hospital. The University Medical Information Network Center(UMIN Center) was opened in the department as a cooperate organization for national medical schools in Japan. The purposes of the UMIN Center are to provide up-to-date communication environment to healthcare professionals via the Internet. In 1997, according to the reconstruction of Graduate School, the Department of Medical Informatics and Economics was established in the Division of Social Medicine, Graduate School of Medicine, and the functions of research and education and the staffs were formally moved from the hospital to the department in the Graduate School of Medicine. However, all the administrative works for providing various services of hospital information management have been conducted by the same staffs as before.

From the responsibilities of the hospital described as above, most of the researches have been based on practical development, integration, and implementation of hospital information systems using an innovative information technology. The scope covers standardization of medical information exchange, evaluation of new technologies for distributed hospital information systems, development of electronic medical record systems(EMRS) and medical decision support systems(MDSS), application of the Internet technology in healthcare fields, and method of knowledge discovery from clinical database. The goal is to contribute to improvement of quality of care using information technology

Faculties and Students

Professor and Chair	Kazuhiko Ohe, M.D., Ph.D. (1997-)
Associate Professors	Takahiro Kiuchi, M.D., Ph.D. (for UMIN Center)
Graduate student	9
Research student.....	2

Past Research and Major Accomplishments

1) Development and evaluation of a hospital information system using open standard and HL7 (1993-Current)

Although the Health Level Seven(HL7) Version 2.1 was the only proposal for connecting distributed information systems in a hospital around 1993, it was no so-called "standard" protocol. Because it was essential for developers of develop large-scale hospital information systems(HISs) to introduce a standard communication protocol that could be generally used in different departmental computer systems and their terminals, an experience and evaluation of real implementation of HL7 in a large-scale HIS were needed in the field of medical informatics in the early '90s. Ohe

designed a new architecture of client-server-type HIS using HL7-based messaging protocol between client terminals and the server over TCP/IP network, which had never been used in Japan. The innovative HIS was successfully implemented based on this new architecture in the University of Tokyo Hospital in 1995 and the good performance was proved in this implementation[7]. This first experience of implementing the standard communication protocol or HL7 contributed to move most HISs in Japan from the vender proprietary systems into multi-vender distributed systems using open standard. Subsequent activities related to the open standard brought about foundation of the Association of HL7 Japan(Ohe is the vice-chair of the technical committee), foundation of Japan Health Information and Communication Standards Board (HELICS Board; Ohe is the Chair of the Board),

2) Modeling a semantic structure of clinical information using object-oriented approach and development of HIS using OODB and CORBA(1996-Current)

Analyzing and Modeling a semantic structure of clinical information in terms of information science

are essential tasks to develop both multi-purpose EMR systems and future intelligent decision support systems. Object-oriented analysis(OOA) and modeling(OOM) were proposed in the '90s as powerful methods to model a semantic relationship among information objects in a target domain and they were gradually applied in various fields as well as medical information. We recognized the importance of the OOA/OOM at the early stage, and focused on applying the approach to developing a future intelligent clinical information systems. At first we analyzed and made a model of data of ECG, and implemented a retrieval system using Object-Oriented Database(OODB)[5,6,10]. The research proved the feasibility and realization of OOA/OOM and OODB system to develop multi-media clinical information systems.

Based on this result, we proposed a new architecture for managing distributed medical information using OODB and CORBA(Common Objects Request Broker Architecture). This approach aimed to share inter-hospital distributed clinical information for improvement of quality of care and quality of multi-institutional large-scale clinical researches. In this research, we have been developing CORBA-based EMR systems in the University of Tokyo Hospitals[12,18,21].

3) Standardization of medical information exchange and terminology (1997-Current)

Ohe and the collaborative researchers in other institutes have been concurrently developing a new standard protocol for exchanging medical information electronically among hospitals in collaboration with the Association of HL7-USA /Japan and related working group of ISO/TC215, in which Ohe is the delegate of Japan of WG3; concept representation). We proposed a protocol named "MML(Medical Markup Language)" based on XML(eXtensible Markup Language) in the early stage of the work[8], and later we proposed a new protocol named "MERIT-9" based on integration of XML, HL7, DICOM, and other de-facto standard through our experiences of implementing the previous protocol[14,16]. This new protocol is in the stage of evaluation in several hospitals in Japan.

In the domain of medical terminology, Japan had double standards of Japanese clinical disease terminology and all of hospitals in Japan have not decided to use which of them for a long time. Ohe and Kaihara, who was a former professor of this department, proposed a method of integrating these two Japanese standard into one unified standard terminology that is available for general-purpose clinical information systems and EDI(Electronic Data Interchange) system of health insurance claim reimbursement. Each term in the unified disease terminology is linked to an ICD-

10 code and semantic relations among the terms. Further a new standard methods to access to a database of the terminology was developed and published as a open software in 2001 by Ohe and the colleagues. Most large-scale university hospitals has been moving to introduce the standard disease terminology since 2002 and Japan Ministry of Health, Labor, and Welfare announced that all of the hospitals must use this terminology including the codes in EDI.

4) Application of the Internet technology to medical field by the UMIN

Application of the Internet technology to medical field by the UMIN has been the major topic of the researches[13,15,17,]. Associate Professor Kiuchi is the director of the UMIN Center and he has been developing and managing the nation-wide medical information network sponsored by the Ministry of Education, Culture, Science, Sports and Technology (MEXT). Using this infrastructure, Kiuchi and his colleagues proposed a standard method of on-line abstract and paper entry and developed a system for Japanese academic medical societies. Hundreds of the societies have been adopting this system and as a result this methods and the system has become the de-facto standard in Japan. Kiuchi and his colleagues also developed Internet-based data collection system for nation-wide clinical and epidemiological research. The system have been enhancing the scale and the efficiency of such research[22].

Current Research

Most of the researches described above is continuing and currently expanded toward the next stage.

1) Enhancing Standardization of electronic representation of medical information:

Revising and evaluating the "MERIT-9" standard protocol in harmonization with HL7 ver.3 that is proposed to cover comprehensive clinical information systems.

2) Implementing large-scale EMR system integrated with order entry system using distributed object technology:

Based on the evaluation study of CORBA-based HIS, we are preparing and developing large-scale EMR system that will be operated from Apr. 2003 in the University of Tokyo Hospital.

3) Trial of knowledge discovery from large-scale medical database created by HIS for future Intelligent decision support system:

We are investigating a method of data mining and

knowledge discovery from large-scale medical database[23].

Future Prospects

We will shift to develop an intelligent decision support system that uses both large-scale clinical database and real-time knowledge discovering process, and for the purpose a new method of data mining including both natural language processing and temporal data processing should be created. Further, we want to focus on a method of creating an practical ontology that is specific to healthcare domain. In other words, integration of management of clinical data and handling of electronic medical knowledge is the next objectives for our goals.

Research Grants

five recent grants selected:

- 1) 2000F.Y.-2001F.Y. Health and Labor Sciences Research Grants of MHLW, Research on Health Technology Assessment, Research on development of formal electronic representation of logics of Japan medical fee payment system and a standard software of source-code generator for calculating medical fee. Head Researcher.
- 2) 2002F.Y Health and Labor Sciences Research Grants of MHLW, Research on Policy Planning and Evaluation, Investigation of DRG for inpatients with acute diseases. Co-researcher.
- 3) 2001F.Y.-2002F.Y. Grants-in-Aid for Scientific Research of MEXT, Scientific Research-C, Development of a method to discover similar cases from clinical database using semantic relationship among medical terms, Head researcher.
- 4) 2001F.Y-2002F.Y. Health and Labor Sciences Research Grants of MHLW, Research on Policy Planning and Evaluation, A study on roles of Health Insurance Agency, Head researcher.
- 5) 1999F.Y.-2001F.Y. Health and Labor Sciences Research Grants of MHLW, Research on Health Technology Assessment, A study on modeling healthcare information domain. Head Researcher.

Select Publications

- 1) Ohe,K., Kaihara,S.: An Object -Oriented Model of Physicians' Strategy at First Encounters - An Approach to sharing Distributed Knowledge-bases. K.C.Lun et al.(eds), Elsevier Science Publishers, B.V.(North-Holland), MEDINFO92: 434-439, 1992.
- 2) Kaihara S., Ohe K., Sakurai T. and Kiuchi T.: HIS and Research. Hospital Information Systems: Scope-Design-Architecture, A.R. Bakker et al. (eds), Elsevier Science Publishers B.V.(North-Holland), 97-101, 1992.
- 3) T. Koyama, K. Ohe: Building a Common Knowledge Base for Internal Medicine. Proceedings of

Korea/Japan Joint Conference on Expert Systems: 876-888,Seoul (Korea), 1993.

- 4) K.Ohe, S.Kaihara, K.B.Ishikawa, T.Hishiki, T.Nagase, T.Sakurai: Hospital Information system and the Internet. K.Chon (ed), Proceedings of the International Networking Conference INET'95, 1033-1036, Internet Society, 1995.
- 5) C.Wang, K.Ohe, T.Sakurai, T.Nagase, S.Kaihara: An ECG Storage and Retrieval System Embedded in Client Server HIS Utilizing Object-Oriented DB. Journal of Medical Systems, 20(1), 35-43, 1996.
- 6) C.Wang, K.Ohe, T.Sakurai, T.Nagase, S.Kaihara: Object-oriented Analysis and Design of an ECG Storage and Retrieval System Integrated with an HIS. Methods of Information in Medicine, 35(1), 35-40, 1996.
- 7) K.Ohe, S.Kaihara: Implementation of HL7 to Client-Server Hospital Information System(HIS) in the University of Tokyo Hospital. Journal of Medical Systems, 197-205, Vol.20, No.4, 1996.
- 8) Yoshihara H., Ohe K., Ohashi K., Yamamoto R., Yamazaki S., Hirose Y., et.al.: Standardization of Exchange Procedures of Clinical Information, and an Experiment of Clinical Data Exchange Using Medical Markup Language (MML). Journal of Japan Medical Informatics, 17(3)Suppl., 203-207,1997.
- 9) Hishiki T.,Ohe K., Kaihara S.: Extraction of Clinical Information from Narrative Medical Records Using Natural Language Processing Journal of Japan Medical Informatics, 17(3)Suppl.,1997.
- 10) Wang C, Ohe K, Kaihara S: Dynamic link between ECG and clinical data by a CORBA-based query engine and temporal mapping. Proceedings of AMIA Annual Fall Symposium,27-31,1997.
- 11) K.Miyo, K.Ohe: SGML-based Construction and Automatic Organization of Comprehensive Medical textbook on the Internet. Proceedings of MEDINFO98, B.Cesnik etal.(Eds), Amsterdam:IOS press,145-149,1998.
- 12) K.Ohe: A Hospital Information System based on Common Object Request Broker Architecture (CORBA) for Exchanging Distributed Medical Objects - an approach to future environment of sharing healthcare information. Proceedings of MEDINFO98, B.Cesnik etal.(Eds), Amsterdam:IOS press,962-964,1998.
- 13) T. Kiuchi, T. Sakurai, K. Ohe, Y. Ohashi, S. Kaihara: University Medical Information Network - Past, Present, and Future. Proceedings of MEDINFO98, B.Cesnik etal.(Eds), Amsterdam:IOS press,420-424,1998.
- 14) M. Kimura, K.Ohe, H. Yoshihara, Y. Ando, F. Kawamata, T. Hishiki, et.al.: Patient Information Exchange Guideline MERIT-9 using Medical Markup Language MML. Proceedings of MEDINFO98, B.Cesnik etal.(Eds), Amsterdam:IOS press,433-437,1998.
- 15) H. Yamakami, T.Kiuchi, T.Nagase, K.Ohe, S.Kaihara, T.Sakurai: Development and Trial operation of a World Wide Web-based data entry system

- for the collection of statistical data on the management of the national university hospitals in Japan. *Medical Informatics*,23(1),19-29,1998.
- 16) M. Kimura, K. Ohe, H. Yoshihara, Y. Ando, F. Kawamata, T. Hishiki, et.al.: MERIT-9; a patient information exchange guideline using MML, HL7, and DICOM. *International Journal of Medical Informatics*, 59-68,51(1),1998.
 - 17) T.Kiuchi, K.Ohe, S.Kaihara: Using WWW-based Mail User Agent for Secure Electronic Mail Service for HealthCare Users, *Methods of Information in Medicine*,37,247-253,1998.
 - 18) C.Wang, K.Ohe: A CORBA-based Object Framework with Patient Identification Translation and Dynamic Linking-Methods for Exchanging Patient Data.,*Method of information in Medicine*,38(1),56-65,1999.
 - 19) D. Koide, K. Ohe, Dennis Ross-Degnan, S.Kaihara: Computerized reminders to monitor liverfunction to improve the use of etretinate. *International Journal of Medical Informatics*,57(2000),11-19, 2000.
 - 20) E.Hanada, Y.Antoku, S.Tani, M.Kimura, A.Hasegawa, S.Urano, K Ohe, Member, IEEE, M.Ymaki, Y.Nose: Electromagnetic interference on medical equipment by low-power mobile telecommunication systems. *IEEE TRANSACTIONS ON ELECTROMAGNETIC COMPATIBILITY*, 42(4),470-476, 2000.
 - 21) K. Ohe, K.Miyo, Y.Onogi, K.Ueda, M.Takada, T.Chihara: Implications of a General data model for implementing OODB/CORBA-based computerized patient record system. *Proceedings of MEDINFO2001*, V.Patel etal.(Eds), Amsterdam:IOS press,789,2001.
 - 22) T.Kiuchi,K. Ohe,T.Sakurai: UMIN-Key information infrastructure for the Japanese Medical Community. *Proceedings of MEDINFO2001*, V.Patel etal.(Eds), Amsterdam:IOS press,1359-1363,2001.
 - 23) D.Koide,K. Ohe: Applying data mining to detection of adverse drug reactions. *Proceedings of MEDINFO2001*, V.Patel etal.(Eds), Amsterdam:IOS press,1421,2001.
 - 24) S.Kataoka, K. Ohe, M.Mochizuki, S.Ueda: Developing and integrating an adverse drug reaction reporting system with the hospital information system. *YAKUGAKU ZASSHI*,122(1),113-116, 2002.
 - 25) Y.Ohyama, K.Funao, E.Kawabe, D.Hayashi, T.Yamazaki, T.Iga, D.Koide, K. Ohe, K.Kubota : Calcium channel blockers and myocardial infarction: A case-control study in a Japanese hospital. *PHARMACOEPIDEMIOLOGY AND DRUG SAFETY*, 2002, 11, 487-492, 2002.

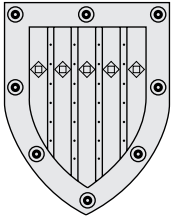

Department of Cardiovascular Medicine

Outline and Research Objectives

In 1998 the Department of Internal Medicine at University of Tokyo hospital was reorganized to the more functional units based on clinical specialties of diseased organs. Cardiologists from 5 departments of Internal Medicine were unified to the Department of Cardiovascular Medicine. We at quite an early phase introduced techniques of molecular biology into the research field of cardiovascular medicine. As a result, we could report following important findings: 1) phenotypic modulation of cardiac or vascular specific proteins occurs during cardiac hypertrophy or arteriosclerosis. 2) intracellular mechanisms on how mechanical stress causes cardiac hypertrophy; 3) identification of novel genes expressed during heart development; 4) development of animal models for cardiovascular diseases by using genetic engineering techniques (i.e. knockout mice of endothelin-1 and KLF5 genes provided new findings for the research of this field); 5) therapeutic angiogenesis for experimental myocardial infarction by growth factors was originally introduced in this department; 6) We are developing an electronic patient record system by which prognosis as well as risk factors of cardiovascular disease can be statistically analyzed. From a research standpoint, our interests range throughout all fields of cardiovascular medicine ranging from molecular biology to clinical research including genomics. Importantly, our research interests are aimed at making possible new diagnostics and treatment of cardiovascular diseases.

Areas of interest are as follows:

- 1) Transcriptional regulation in cardiovascular pathogenesis
- 2) Risk factor analysis of cardiovascular disease
- 3) Pathogenic mechanisms of cardiac hypertrophy and heart failure
- 4) Immunological basis of myocarditis and dilated cardiomyopathy
- 5) MRI in cardiovascular diseases
- 6) Early diagnosis of ischemic heart disease using radionuclide testing
- 7) Aerobic threshold and cardiac rehabilitation
- 8) Anti-arrhythmia therapy using atrial remodeling
- 9) Mechanism of post-PTCA restenosis
- 10) Molecular mechanisms of reperfusion injury
- 11) Genetic polymorphisms in cardiovascular disease
- 12) Differentiation of smooth muscle cells
- 13) Cardiac development
- 14) Gene expression and regulation in cardiomyocytes
- 15) Mouse genetic models of cardiovascular diseases and vascular development
- 16) Nitric oxide and endothelial function
- 17) Gene therapy of heart failure using cardiac contractile proteins
- 18) Clinical application of vasoactive substances

Faculties and Students

Professor and Chair Ryozo Nagai, MD, PhD (1999~)
Lecturer Yasunobu Hirata, MD, PhD
Minoru Ohno, MD, PhD
Yoshinori Seko, MD, PhD

Associate14
Postdoctoral Fellow11
Graduate student28
Research student.....7
Secretary4

Past Research and Major Accomplishments

1) Transcriptional regulation of expression of genes related to cardiovascular diseases

We have been focusing our research on the role of transcriptional regulation of gene expression in the cardiovascular system with a particular interest on regulation of phenotypic modulation of smooth muscle and cardiac cells. In 1980s and early 1990s, Nagai et al isolated and characterized three types of smooth

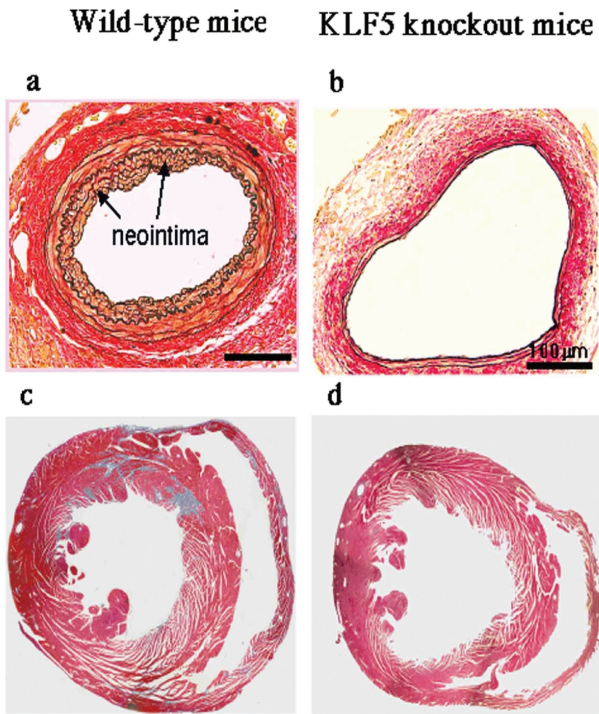

Figure 1

muscle myosin heavy chains and found that they are differentially expressed during vascular development. Nagai et al furthermore isolated a DNA-binding factor, Krüppel-like factor 5 (KLF5), as a transcription factor of the embryonic isoform of smooth muscle myosin heavy chain gene (SMemb), whose expression is induced in phenotypically modulated smooth muscle cell and cardiac fibroblast. Recently, by developing knockout mice of KLF5 gene, we have found that KLF5 is an essential regulator of cardiovascular remodeling which occurs in response to various external stresses (Figure 1). We have further found that differential chemical modifications and protein-protein interactions regulate this family of factors. We are currently investigating whether low molecular weight compounds that inhibit functions of KLF5 are clinically applicable as a new therapeutic drug against cardiovascular diseases.

2) Differentiation of smooth muscle cells in vascular lesions

On the contrary to general assumption that neointima cells are derived from medial smooth muscle cells, we found that bone marrow cells give rise to the majority of smooth muscle cells that contribute to arterial remodeling in models of post-angioplasty restenosis, graft vasculopathy and hyperlipidemia-induced atherosclerosis. Notably, we found purified hematopoietic stem cells differentiated into smooth muscle cells *in vitro* and *in vivo*. We proposed that among blood cells there may be progenitors of smooth muscle cells, which attach to the injured endothelia, differentiate into smooth muscle cells and

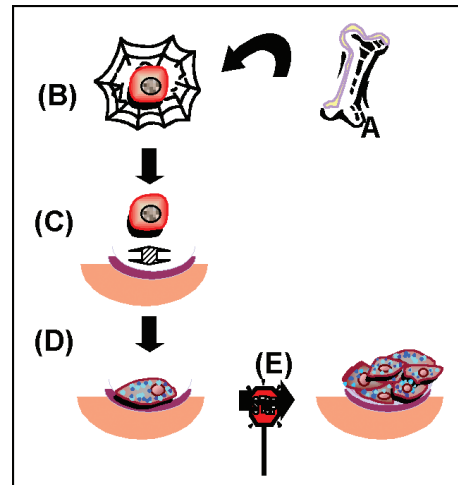

Fig. 2 Strategies targeting vascular progenitors

proliferate, contributing thereby to neointima formation. Our results will also suggest a novel strategy to prevent vascular diseases, targeting mobilization (A), circulation (B), homing (C), differentiation (D) and proliferation (E) of putative smooth muscle progenitor cells (Figure 2).

3) Establishment of clinical data management system and its practical application to genetic epidemiology in cardiovascular medicine

We have established a clinical data analysis system on network, which enrolls more than 2000 patients who underwent coronary angiography in our department. By using this system we can analyze the relationship between the genetic polymorphisms and the clinical of cardiovascular diseases such as coronary artery diseases (CAD) and ischemic stroke. We demonstrated that the alanine/valine (A/V) polymorphism in the gene of 5,10-methylenetetrahydrofolate reductase (MTHFR) genes is a significant genetic risk factor for CAD and ischemic stroke. This genetic variant is a more powerful predictor of atherosclerotic diseases, when the plasma folate levels are relatively low.

4) Development of mouse genetic models of cardiovascular diseases

Our research interests include the pathophysiological assessment of cardiovascular diseases by mice gene engineering approach. We have generated knockout and transgenic mice of adrenomedullin, ADAMTS-1, endothelin-1 and KLF5. We analyzed the role of these genes and found that their expression is essential for normal growth of mice.

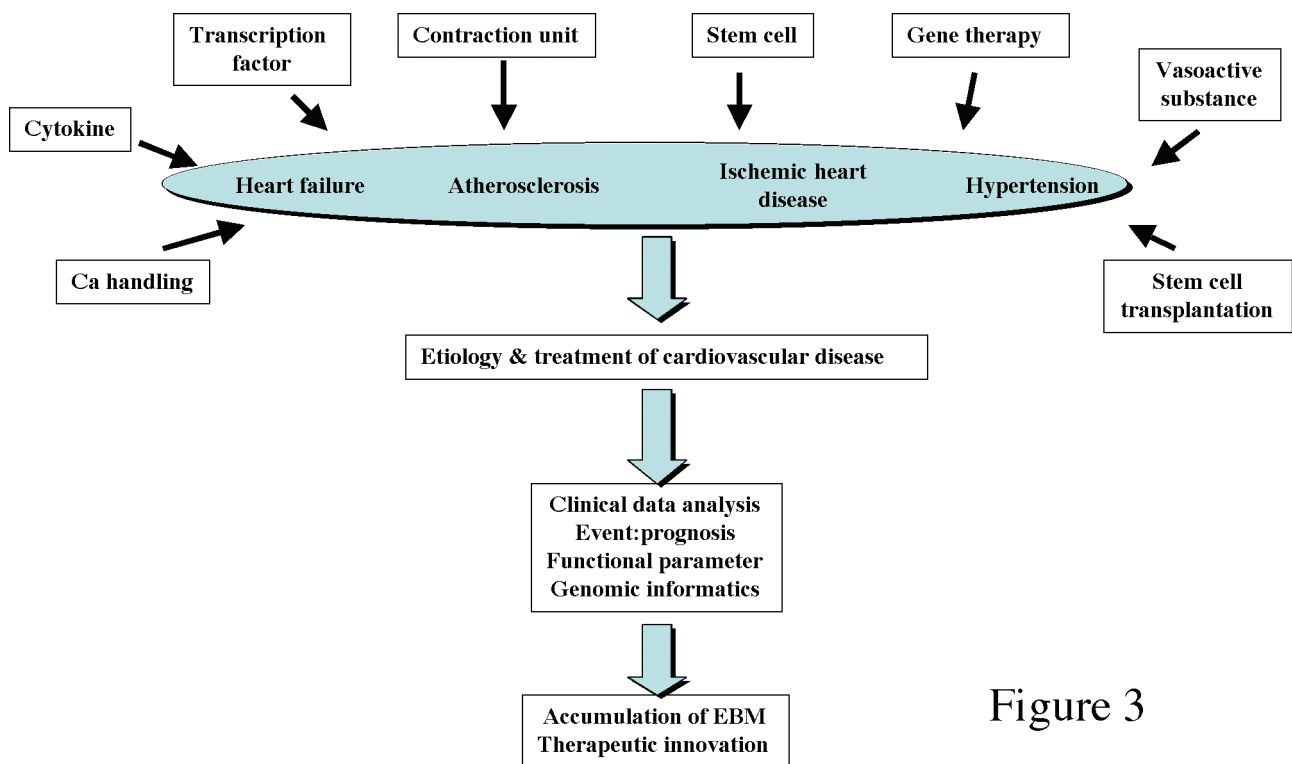

Figure 3

Figure 3 summarizes our strategy for clinical application of basic research on cardiovascular disease.

Current Research

1) Transcription factor such as Krüppel-like factors in pathogenic mechanisms.

Modulation of transcription factors may lead to a new therapeutic strategy for cardiovascular disease. Ongoing studies include using proteomics approaches to understand the diverse protein-protein interactions and regulation of these Krüppel-like factors. We have already identified a novel repressor protein among others. Another focus of research surrounds understanding the transcriptional regulation of these Krüppel-like factors in the context of chromatin which is necessary to understand how transcription occurs in humans.

2) Bone marrow-derived vascular progenitor cells

(1) Identification of bone marrow fraction contributing to atherosclerosis

To determine which fraction of bone marrow cells contribute to the pathogenesis of vascular diseases, we are reconstituting bone marrow of the lethally irradiated recipient mice with the hematopoietic stem cells from LacZ mouse and the mesenchymal stem cells from GFP mouse. We are applying following vascular injury models to bone marrow-reconstitution mice: mouse femoral injury model, heterotopic cardiac transplantation model and atherosclerotic model.

(2) Characterization of bone marrow-derived vascular progenitor cells

By using cell sorter, we are identifying which frac-

tion of peripheral blood cells effectively differentiates into smooth muscle cells. We are determining the cell surface marker to isolate the putative bone marrow-derived smooth muscle progenitor cells. Using bone marrow transplantation mice, we are identifying the effects of hyperlipidemia and drugs on mobilization, homing, differentiation of the progenitor cells in various models of vascular injury described above

3) Establishment of clinical data management system.

To overcome the difficulty of filing complicated clinical parameters for genetic association studies, we are accumulating clinical data and constructing our original database system. For genetic analyses, written informed consent to participate was obtained from all the in-patients in our department. DNA samples obtained from the participants have reached approximately one thousand. Using them, we analyzed over 50 genetic polymorphisms implicated to be associated with atherosclerotic diseases. Among plenty of SNPs analyzed in our study, we showed the polymorphisms in the MMP-1 and MMP-3 promoters are associated with disease susceptibility to myocardial infarction. Also, our database system supports several ongoing clinical epidemiological studies such as J-CAD.

4) Genetic engineering for analysis of the role of endogenous protein

We are analyzing the *in vivo* function of KLF5 using knockout mice. In response to external stress,

KLF5 knockout mice exhibited diminished levels of arterial wall thickening, cardiac hypertrophy, interstitial fibrosis and that angiotensin II induced expression of KLF5, which in turn activated growth factor expression. KLF5 thus appears to be a key element linking external stress and cardiovascular remodeling.

Future Prospects

- 1) Dissection of the pathogenic mechanisms whereby the Krüppel-like factors are involved in cardiovascular disease will allow us to understand the diverse mechanisms by which this family of factors are involved in transcriptional regulation. By such, we envision that targeted drug design to modulate these factors in this context will enable us to propose a new therapeutic approach to cardiovascular disease (e.g. pin-point drug design).
- 2) Using our database system we have followed all the cases periodically, thus we can get prospective clinical data such as major cardiovascular events and responsiveness to treatment such as drugs and percutaneous coronary intervention. In future, we will be able to obtain several evidences from our database system and genetic analyses, resulting in clinical application of such evidences in prediction or prevention of major cardiovascular diseases.
- 3) We have shown that KLF5 is a crucial determinant of the cellular response to cardiovascular injury, playing a key role in mediating cardiovascular remodeling. We are now analyzing the effect of compounds, which could modulate KLF5 function to control remodeling in atherosclerosis and heart failure.
- 4) Our studies will show that bone marrow cells including hematopoietic stem cells have the potential to give rise to vascular progenitor cells that home in the damaged vessels, differentiate into smooth muscle cells, and proliferate thereby contributing to vascular remodeling. We expect that atherogenic factors such as hyperlipidemia, inflammation, cytokines, and smoking will facilitate the kinetics of smooth muscle progenitors. Our findings will provide the basis for the development of new diagnostic strategies to predict atherosclerosis by quantifying the circulating progenitors.

Research Grants

Ryozo Nagai (1997-2001)
 Grant from the Organization for Pharmaceutical Safety and Research
 Role of Klotho gene and its clinical application in cardiovascular disease

Ryozo Nagai (1999-2001)
 Grant from the Ministry of Health, Labour and Welfare
 Research on elucidation of the molecular mechanisms of specific diseases

Ryozo Nagai (2000-2002)
 Grant from the Ministry of Education, Culture, Sports, Science and Technology
 Development of a new prognostic evaluation system and treatment for patients with cardiovascular disease based on gene polymorphisms

Ryozo Nagai (2000-2002)
 Grant from the Ministry of Health, Labor and Welfare
 Research on development of angiogenesis and vascular protection treatment

Ryozo Nagai (2002-2006)
 Grant from the Ministry of Education, Culture, Sports, Science and Technology
 Molecular mechanism and organ remodeling: gene transcription and cell-cell interaction in mesenchymal cells

Select Publications

Diversity of smooth muscle myosin heavy chain isoforms

1. Nagai R, Larson DM, Periasamy M. Characterization of a mammalian smooth muscle myosin heavy chain cDNA and its expression in various smooth muscle types. *Proc Natl Acad Sci USA* 85: 1047-1051, 1988.
2. Nagai R, Kuro-o M, Babij P, Periasamy M. Identification of two types of smooth muscle myosin heavy chain isoforms by cDNA cloning and immunoblot analysis. *J Biol Chem* 264: 9734-9737, 1989.
3. Kuro-o M, Nagai R, Tsuchimochi H, Katoh H, Yazaki Y, Ohkubo A, Takaku F. Developmentally regulated expression of vascular smooth muscle myosin heavy chain isoforms. *J Biol Chem* 264: 18272-18275, 1989.
4. Kuro-o M, Nagai R, Tsuchimochi H, Katoh H, Tsai R-C, Yazaki Y, Ohkubo A, Takaku F. cDNA cloning of a myosin heavy chain isoform in embryonic smooth muscles and its expression during vascular development and in arteriosclerosis. *J Biol Chem* 266: 3768-3773, 1991.
5. Kim H-S, Aikawa M, Kimura K, Kuro-o M, Nakahara K, Suzuki T, Katoh H, Okamoto E, Yazaki Y, Nagai R. Ductus arteriosus: advanced differentiation of smooth muscle cells demonstrated by myosin heavy chain isoform expression in rabbits. *Circulation* 88: 1804-1810, 1993.
6. Aikawa M, Nalla Sivam P, Kuro-o M, Kimura K, Nakahara K, Takewaki S, Yamaguchi H, Yazaki Y, Periasamy M, Nagai R. Human smooth muscle myosin heavy chain isoforms as molecular markers for vascular development and atherosclerosis. *Circ Res* 73: 1000-1012, 1993.

7. Suzuki T, H-S Kim, Kurabayashi M, Hamada H, Fujii H, Aikawa M, Watanabe M, Yazaki Y, Nagai R Preferential differentiation of P19 mouse embryonal carcinoma cells into smooth muscle cells: use of retinoic acid and antisense against the central nervous system-specific POU transcription factor Brn-2. *Circ Res* 78:395-404,1996.

Regulation of smooth muscle cell differentiation and cardiovascular remodeling

1. Watanabe M, Sakomura Y, Kurabayashi M, Manabe I, Aikawa M, Kuro-o M, Suzuki T, Yazaki Y, Nagai R Structure and characterization of the 5'-Flanking Region of the mouse smooth muscle myosin heavy chain (SM1/2) gene. *Circ Res* 78: 978-989, 1996.
2. Manabe I, Kurabayashi M, Shimomura Y, Kuro-o M, Watanabe N, Watanabe M, Aikawa M, Suzuki T, Yazaki Y, Nagai R Isolation of the embryonic form of smooth muscle myosin heavy chain (SMemb/NMHC-B) gene and characterization of its 5'-flanking region. *Biochem Biophys Res Commun* 239:598-605, 1997.
3. Watanabe N, Kurabayashi M, Shimomura Y, Kawai-Kowase K, Hoshino Y, Manabe I, Watanabe M, Aikawa M, Kuro-o M, Suzuki T, Yazaki Y, Nagai R BTEB2, a Krppel-like transcription factor, regulates expression of the SMemb/Nonmuscle myosin heavy chain B (SMemb/NMHC-B) gene *Circ Res* 85: 182-191, 1999.
4. Kawai-Kowase K, Kurabayashi M, Hoshino Y, Ohyama Y, Nagai R. Transcriptional activation of the zinc finger transcription factor BTEB2 gene by Egr-1 through mitogen-activated protein kinase pathways in vascular smooth muscle cells *Circ Res* 85: 787-795, 1999.
5. Hoshino Y, Kurabayashi M, Kanda T, Hasegawa A, Sakamoto H, Okamoto Ei, Kowase K, Watanabe N, Manabe I, Suzuki T, Nakano A, Takase Si, Wilcox JN, Nagai R. Regulated expression of the BTEB2 transcription factor in vascular smooth muscle cells : analysis of developmental and pathological expression profiles shows implications as a predictive factor for restenosis. *Circulation* 102: 2528-2534, 2000.
6. Sekiguchi K, Kurabayashi M, Oyama Y, Aihara Y, Tanaka T, Sakamoto H, Hoshino Y, Kanda T, Yokoyama T, Shimomura Y, Iijima H, Ohyama Y, Nagai R. Homeobox protein hex induces SMemb/Nonmuscle myosin heavy chain-B gene expression through the cAMP-responsive element. *Circ Res* 88: 52-28, 2001.
7. Shindo T, Manabe I, Fukushima Y, Tobe K, Aizawa K, Miyamoto S, Kawai-Kowase K, Moriyama N, Imai Y, Kawakami H, Nishimatsu H, Ishikawa T, Suzuki T, Morita H, Maemura K, Sata M, Hirata Y, Komukai M, Kagechika H, Kadowaki T, Kurabayashi M, Nagai R. Krppel-like zinc-finger transcription factor KLF5/BTEB2 is a target for angiotensin II signaling and an essential regulator of cardiovascular remodeling. *Nature Med.* 8:856-873, 2002.
8. Saiura A, Sata M, Hirata Y, Nagai R, Makuuchi M. Circulating smooth muscle progenitor cells con-

tribute to atherosclerosis. *Nature Med.* 7: 382-383, 2001.

9. Sata M, Saiura A, Kunisato A, Tojo A, Okada S, Tokuhisa T, Hirai H, Makuuchi M, Hirata Y, Nagai R. Hematopoietic stem cells differentiate into vascular cells that participate in the pathogenesis of atherosclerosis. *Nature Med.* 8: 403-409, 2002.

Identification and function of anti-aging gene *klotho*

1. Kuro-o M, Matsumura Y, Aizawa H, Kawaguchi H, Suga T, Utsugi T, Ohyama Y, Kurabayashi M, Kaname T, Kume E, Iwasaki H, Iida A, Shiraki-Iida T, Nishikawa S, Nagai R, Nabeshima Y. Mutation of the mouse *Klotho* gene leads to a syndrome resembling ageing. *Nature* 390: 45-51, 1997.
2. Saito Y, Yamagishi T, Nakamura T, Ohyama Y, Aizawa H, Suga T, Matsumura Y, Masuda H, Kurabayashi M, Kuro-o M, Nabeshima Y, Nagai R. *Klotho* protein protects against endothelial dysfunction. *Biochem Biophys Res Commun* 248: 324-329, 1998.
3. Aizawa H, Saito Y, Nakamura T, Inoue M, Imanari T, Ohyama Y, Matsumura Y, Masuda H, Oba S, Mise N, Kimura K, Hasegawa A, Kurabayashi M, Kuro-o M, Nabeshima Y, Nagai R. Downregulation of the *klotho* gene in the kidney under sustained circulatory stress in rats. *Biochem Biophys Res Commun* 249: 865-871, 1998.
4. Suga T, Kurabayashi M, Sando Y, Ohyama Y, Maeno T, Maeno Y, Aizawa H, Matsumura Y, Kuwaki T, Kuro-o M, Nabeshima Y, Nagai R. Disruption of the *klotho* gene causes pulmonary emphysema in mice: defect in maintenance of pulmonary integrity during postnatal life *Am J Respir Cell Mol Biol* 22: 26-33, 2000.
5. Nagai R, Saito Y, Ohyama Y, Aizawa H, Suga T, Nakamura T, Kurabayashi M, Kuro-o M Endothelial dysfunction in the *klotho* mouse and downregulation of *klotho* gene expression in various animal models of vascular and metabolic diseases. *Cell Mol Life Sci* 57: 738-746, 2000.
6. Saito Y, Nakamura T, Ohyama Y, Suzuki T, Iida A, Shiraki-Iida T, Kuro-o M, Nabeshima Y, Kurabayashi M, Nagai R. In vivo *klotho* gene delivery protects against endothelial dysfunction in multiple risk factor syndrome. *Biochem Biophys Res Commun* 276:767-772, 2000.
7. Mitani H, Ishizaka N, Aizawa T, Ohno M, Usui S, Suzuki T, Amaki T, Mori I, Nakamura Y, Sato M, Nangaku M, Hirata Y, Nagai R. In vivo *klotho* gene transfer ameliorates angiotensin II-induced renal damage. *Hypertension.* 39:838-843, 2002.

Intracellular signaling and transcription factors of cardiac hypertrophy

1. Kojima M, Shiojima I, Yamazaki T, Komuro I, Nagai R, Yazaki Y. Angiotensin II receptor antagonist TC116 regresses hypertensive left ventricular hypertrophy in vivo and inhibits intracellular signal-

ing pathway of stretch-mediated cardiomyocyte hypertrophy in vitro. *Circulation* 89: 2204-2211, 1994

2. Shimoyama M, Hayashi D, Takimoto E, Zou Y, Oka T, Uozumi H, Kudoh S, Shibasaki F, Yazaki Y, Nagai R, Komuro I. Calcineurin plays a critical role in pressure overload-induced cardiac hypertrophy. *Circulation*. 100:2449-2454, 1999.
3. Zhu W, Zou Y, Aikawa R, Harada K, Kudoh S, Uozumi H, Hayashi D, Gu Y, Yamazaki T, Nagai R, Yazaki Y, Komuro I. MAPK superfamily plays an important role in daunomycin-induced apoptosis of cardiac myocytes. *Circulation*. 100:2100-2107, 1999.
4. Aikawa R, Nawano M, Gu Y, Katagiri H, Asano T, Zhu W, Nagai R, Komuro I. Insulin prevents cardiomyocytes from oxidative stress-induced apoptosis through activation of PI3 kinase/Akt. *Circulation*. 102: 2873-2879, 2000.
5. Hiroi Y, Kudoh S, Monzen K, Ikeda Y, Yazaki Y, Nagai R, Komuro I. Tbx5 associates with Nkx2-5 and synergistically promotes cardiomyocyte differentiation. *Nature Genet*. 28:276-280, 2001.
6. Hosoda T, Monzen K, Hiroi Y, Oka T, Takimoto E, Yazaki Y, Nagai R, Komuro I. A novel myocyte-specific gene Midori promotes the differentiation of P19CL6 cells into cardiomyocytes. *J Biol Chem*. 276:35978-35989, 2001.
7. Uozumi H, Hiroi Y, Zou Y, Takimoto E, Toko H, Niu P, Shimoyama M, Yazaki Y, Nagai R, Komuro I. gp130 plays a critical role in pressure overload-induced cardiac hypertrophy. *J Biol Chem*. 276: 23115-23119, 2001.
8. Zou Y, Hiroi Y, Uozumi H, Takimoto E, Toko H, Zhu W, Kudoh S, Mizukami M, Shimoyama M, Shibasaki F, Nagai R, Yazaki Y, Komuro I. Calcineurin plays a critical role in the development of pressure overload-induced cardiac hypertrophy. *Circulation*. 104:97-101, 2001.
9. Zou Y, Hiroi Y, Uozumi H, Takimoto E, Toko H, Zhu W, Kudoh S, Mizukami M, Shimoyama M, Shibasaki F, Nagai R, Yazaki Y, Komuro I. Calcineurin plays a critical role in the development of pressure overload-induced cardiac hypertrophy. *Circulation*. 104:97-101, 2001.
10. Takimoto E, Yao A, Toko H, Takano H, Shimoyama M, Sonoda M, Wakimoto K, Takahashi T, Akazawa H, Mizukami M, Nagai T, Nagai R, Komuro I. Sodium calcium exchanger plays a key role in alteration of cardiac function in response to pressure overload. *FASEB J* 16:373-378, 2002.

Cardiovascular pathophysiology

1. Kurihara Y, Kurihara H, Suzuki H, Kodama T, Maemura K, Nagai R, Oda H, Kuwaki T, Cao WH, Kamada N, Jishage K, Ouchi Y, Azume S, Toyoda Y, Ishikawa T, Kumada M, and Yazaki Y. Elevated blood pressure and craniofacial abnormalities in mice deficient in endothelin-1. *Nature* 368: 703-710, 1994.
2. Kuro-o M, Hanaoka K, Hiroi Y, Noguchi T, Fujimori Y, Takewaki S, Hayasaka M, Katoh H, Miyagishi A,

Nagai R, Yazaki Y, Nabeshima Y. Salt-sensitive hypertension in transgenic mice overexpressing sodium-proton exchanger. *Circ Res* 76: 148-153, 1995.

3. Shindo T, Kurihara H, Kuno K, Yokoyama H, Wada T, Kurihara Y, Imai T, Wang Y, Ogata M, Nishimatsu H, Moriyama N, Oh-hashii Y, Morita H, Ishikawa T, Nagai R, Yazaki Y, Matsushima K. ADAMTS-1: a metalloproteinase-disintegrin essential for normal growth, fertility, and organ morphology and function. *J Clin Invest*. 105:1345-1352, 2000.
4. Shindo T, Kurihara H, Maemura K, Kurihara Y, Kuwaki T, Izumida T, Minamino N, Ju KH, Morita H, Oh-hashii Y, Kumada M, Kangawa K, Nagai R, Yazaki Y. Hypotension and resistance to lipopolysaccharide-induced shock in transgenic mice overexpressing adrenomedullin in their vasculature. *Circulation*. 101:2309-2316, 2000.
5. Shindo T, Kurihara Y, Nishimatsu H, Moriyama N, Kakoki M, Wang Y, Imai Y, Ebihara A, Kuwaki T, Ju KH, Minamino N, Kangawa K, Ishikawa T, Fukuda M, Akimoto Y, Kawakami H, Imai T, Morita H, Yazaki Y, Nagai R, Hirata Y, Kurihara H. Vascular abnormalities and elevated blood pressure in mice lacking adrenomedullin gene. *Circulation*. 104:1964-1971, 2001.
6. Morita H, Kurihara H, Yoshida S, Saito Y, Shindo T, Oh-Hashii Y, Kurihara Y, Yazaki Y, Nagai R. Diet-induced hyperhomocysteinemia exacerbates neointima formation in rat carotid arteries after balloon injury. *Circulation*. 103:133-139, 2001
7. Yasuda SI, Sugiura S, Kobayakawa N, Fujita H, Yamashita H, Katoh K, Saeki Y, Kaneko H, Suda Y, Nagai R, Sugi H. A novel method to study contraction characteristics of a single cardiac myocyte using carbon fibers. *Am J Physiol Heart Circ Physiol*. 281:H1442-6, 2001.
8. Ishizaka N, Aizawa T, Ohno M, Usui Si S, Mori I, Tang SS, Ingelfinger JR, Kimura S, Nagai R. Regulation and localization of HSP70 and HSP25 in the kidney of rats undergoing long-term administration of angiotensin II. *Hypertension*. 39:122-128, 2002.

NO and intracellular signaling pathways

1. Nagata D, Suzuki E, Nishimatsu H, Yoshizumi M, Mano T, Walsh K, Sata M, Kakoki M, Goto A, Omata M, Hirata Y. Cyclin A downregulation and p21(cip1) upregulation correlate with GATA-6-induced growth arrest in glomerular mesangial cells. *Circ Res*. 87: 699-704, 2000.
2. Sata M, Kakoki M, Nagata D, Nishimatsu H, Suzuki E, Aoyagi T, Sugiura S, Kojima H, Nagano T, Kangawa K, Matsuo H, Omata M, Nagai R, Hirata Y. Adrenomedullin and nitric oxide inhibit human endothelial cell apoptosis via a cyclic GMP-independent mechanism. *Hypertension*. 36: 83-88, 2000.
3. Suzuki E, Nagata D, Yoshizumi M, Kakoki M, Goto A, Omata M, Hirata Y. Reentry into the cell cycle of contact-inhibited vascular endothelial cells by a phosphatase inhibitor. Possible involvement of

extracellular signal-regulated kinase and phosphatidylinositol 3-kinase. *J Biol Chem.* 275: 3637-3644, 2000

4. Nagata D, Suzuki E, Nishimatsu H, Satonaka H, Goto A, Omata M, Hirata Y. Transcriptional activation of the cyclin D1 gene is mediated by multiple cis-elements, including SP1 sites and a cAMP-responsive element in vascular endothelial cells. *J Biol Chem.* 276: 662-669, 2001.
5. Nishimatsu H, Suzuki E, Nagata D, Moriyama N, Satonaka H, Walsh K, Sata M, Kangawa K, Matsuo H, Goto A, Kitamura T, Hirata Y. Adrenomedullin induces endothelium-dependent vasorelaxation via the phosphatidylinositol 3-kinase/Akt-dependent pathway in rat aorta. *Circ Res.* 89: 63-70, 2001.
6. Nishimatsu H, Hirata Y, Shindo T, Kurihara H, Kakoki M, Nagata D, Hayakawa H, Satonaka H, Sata M, Tojo A, Suzuki E, Kangawa K, Matsuo H, Kitamura T, Nagai R. Role of endogenous adrenomedullin in the regulation of vascular tone and ischemic renal injury: studies on transgenic/knockout mice of adrenomedullin gene. *Circ Res.* 90: 657-663, 2002.
7. Suzuki N, Kojima H, Urano Y, Kikuchi K, Hirata Y, Nagano T. Orthogonality of calcium concentration and ability of 4,5-diaminofluorescein to detect NO. *J Biol Chem* 277:47-49, 2002.
- Nagai R. A novel biochemical diagnostic method for aortic dissection - the results of a prospective study using an immunoassay of smooth muscle myosin heavy chain. *Circulation* 93:1244-1249, 1996
2. Yokoyama I, Yonekura K, Ohtake T, Yang W, Shin WS, Yamada N, Ohtomo K, Nagai R. Coronary microangiopathy in type 2 diabetic patients: relation to glycemic control, sex, and microvascular angina rather than to coronary artery disease. *J Nucl Med* 41: 978-985, 2000
3. Iwasaki T, Iwasaki T, Aihara Y, Kanda T, Oriuchi N, Endo K, Katoh H, Suzuki T, Nagai R. Immunoscintigraphy of aortic dissection with 99mTc-labeled murine anti-smooth muscle myosin monoclonal antibody in rats. *J Nucl Med* 42: 130-137, 2001
4. Yokoyama I, Yonekura K, Moritan T, Tateno M, Momose T, Ohtomo K, Inoue Y, Nagai R. Troglitazone improves whole-body insulin resistance and skeletal muscle glucose use in type II diabetic patients. *J Nucl Med.* 42:1005-1010, 2001.

Genetics of cardiovascular disease

1. Tanaka T, Nagai R, Tomoike H, Takata S, Yano K, Yabuta K, Haneda N, Nakano O, Shibata A, Sawayama T, Kasai H, Yazaki Y, Nakamura Y. Four novel KVLQT1 and four novel HERG mutations in familial long QT syndrome. *Circulation* 95: 565-567, 1997.
2. Nakajima T, Furukawa T, Tanaka T, Katayama Y, Nagai R, Nakamura Y, Hiraoka M. Novel mechanism of HERG current suppression in LQT2 shift in voltage dependence of HERG inactivation. *Circ Res* 83:415-422, 1998.
3. Itoh T, Tanaka T, Nagai R, Kamiya T, Sawayama T, Nakayama T, Tomoike H, Sakurada H, Yazaki Y, Nakamura Y. Genomic organization and mutational analysis of HERG, a gene responsible for familial long QT syndrome. *Hum Genet* 102: 435-439, 1998
4. Itoh T, Tanaka T, Nagai R, Kikuchi K, Ogawa S, Okada S, Yamagata S, Yano K, Yazaki Y, Nakamura Y. Genomic organization and mutational analysis of KVLQT1, a gene responsible for familial long QT syndrome. *Hum Genet* 103: 290-294, 1998
5. Iwasa H, Itoh T, Nagai R, Nakamura Y, Tanaka T. Twenty single nucleotide polymorphisms (SNPs) and their allelic frequencies in four genes that are responsible for familial long QT syndrome in the Japanese population. *J Hum Genet* 45: 182-183, 2000

Diagnosis and imaging of cardiovascular disease

1. Suzuki T, Katoh H, Watanabe M, Kurabayashi M, Hiramori K, Hori S, Nobuyoshi M, Tanaka H, Kodama K, Sato H, Suzuki S, Tsuchio Y, Yazaki Y,

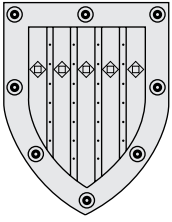

Department of Gastroenterology

Department Objectives

The goal of our department is to accurately diagnose and give the best available treatment to patients, and develop better modalities for the future.

To attain the goal, we perform clinical and basic research.

Outline

In 1998, our current Department of Gastroenterology was established through the reorganization of the Divisions of Internal Medicine, and is in charge of busy clinical practices; 5,000 outpatients a month and 1,200 new admissions a year. The most frequent cause of admission is hepatocellular carcinoma, 500 a year, followed by gastrointestinal tract disorders 400, pancreatobiliary 180, and others 120.

Outline-Hepatology

Unlike other countries, the majority (more than 90%) of our patients with liver disease are due to *hepatitis virus* infection. Therefore, better understanding of virus replication and pathogenesis may eventually lead to the eradication of the virus and the cure of diseases.

We have developed unique ablation treatment for hepatocellular carcinoma (HCC), for which many patients have visited our department (Fig. 1); we have had 1,600 cases, probably the largest series in the world as a single institute experience.

Outline -Gastroenterology

Gastric cancer is the commonest cause of death in Japan. Similar to HCC, there is now enough evidence that bacterial infection, *Helicobacter pylori*, induces or is at least strongly related to cancer development. Along with clinical expertise like *en bloc* resection of cancer (Fig. 2), better understanding of gastric injury due the infection could reduce the most common cause of death in Japan.

Recent increase in the number of colonic cancer is so noticeable. We found that this is mainly due to increase in right sided colon (cecum and ascending colon) cancer in elderly patients. The better understanding of right sided as well as left sided colonic cancers may prevent further increase in the colonic neoplasm in a country where people enjoy unprecedented length of life.

Outline -Pancreatobiliary

Pancreatic cancer with incredibly poor prognosis (average survival of 200 days) is insidiously increasing in Japan. There is not even a clue for high risk group. We need, though difficult, to find out high risk groups and better treatment.

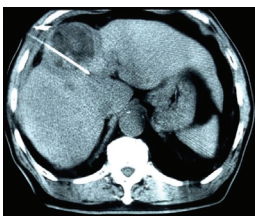

Fig 1. Percutaneous tumor ablation.

(A) During treatment: fine needle was inserted into the tumor.
(B) After treatment: the tumor was completely ablated

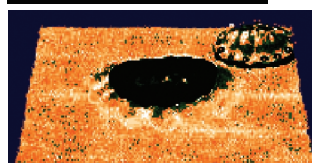

Fig 2. Endoscopic tumor resection.

(A) After injection of saline, the tumor was cut around.
(B) *en bloc* resection: the tumor was completely removed.

Faculties and Students

Professor and Chair	Masao Omata, M.D., Ph.D. (from 1992)
Lecturer	Takao Kawabe, M.D., Shin Onishi, M.D.
Associate	19
Postgraduate Fellow	33
Graduate Student.....	23
Research Student	7
Secretary	2

Past Research and Major Accomplishments

1. Acute and Chronic Liver Injury due to HBV (Hepatitis B Virus)

The most severe form of acute liver injury is *fulminant hepatitis* of which 70% is fatal.

However, the underlying mechanisms of severe injury have not been clear.

We elucidated for the first time the fulminant hepatitis was induced by HBV mutant form (N Engl J Med 1991;324:1699-1704).

Furthermore, this mutant carries specific amino acid changes in nucleocapsid region, a possible target of lymphocyte attack (J Clin Invest 1993;91:1206 - 1213).

These mutations play a critical role not only in acute but also chronic liver disease (J Clin Invest 1992;89:332-338, Gastroenterology 1993;104:263-271).

By these understandings, we explored how to treat these wild and mutant strains.

We set up *in vitro* system to maintain these wild and mutant virus replication and identified extremely effective drugs (J Clin Invest 1999;103:1635-1640, J Clin Invest 2001;107:449-455).

These drugs are now on clinical trials to prevent fulminant hepatitis and even the decompensated cirrhosis to save patients life.

2. Liver Injury due to HCV (Hepatitis C Virus)

In contrast to HBV, HCV infection is mild but insidious and long-lasting disease to carcinoma.

All of these start with very high chronicity rate (80%) of acute hepatitis. We elucidated for the first time that this is nearly 100% preventable by anti-viral treatment (Lancet 1991;338:914-915, Gastroenterology 1994;107:805-811). Since HCV vaccine has not been developed, the above mentioned is the best available procedure to prevent chronicity. In fact, a study from Germany recently reported identical results (N Engl J Med 2001;345:1452-1457). However, there are still 2 million carriers who already have chronic infection. In fact, over 80% of patients with HCC are due to HCV infection in Japan. To prevent

HCC, we first revealed natural course of chronic hepatitis to HCC; this is by step-wise progression of hepatic fibrosis (Ann Intern Med 2000;132:517-524). And eradication of virus by interferon could reduce the incidence of HCC (Ann Intern Med 1999;131:174-181) with resolution of hepatic fibrosis even in cirrhosis, previously thought irreversible (Ann Intern Med 2000;132:517-524). Furthermore, it was recently revealed that overall mortality (not just HCC) was reduced in treatment cohort (Gastroenterology 2002;123: 483-491). By these studies, we now know how to prevent, but question is how to treat patients who already have the cancer. Probably our department is the largest referral center of HCC (500 cases a year), some are from outside Japan, seeking our medical tumor ablation treatment (Fig. 1).

We recently finished our 7-year prospective randomized trial in that we combined radical cure of the cancer nodules by ablation and eradication of HCV by interferon. The 7-year survival of these patients reached 75% (Ann Intern Med 2002; in press). This is compatible or somewhat better than those reported in liver transplantation. When I graduated medical school 30 years ago, liver disease was the one impossible to treat, but now able to envision to how to cure all.

3. Gastric Injury

Gastric cancer is number one cause of death in Japan. More than 80% is supposed to be due to *H. pylori* infection; 90% eradication of the bacteria is now possible by proper treatment. Thus, we decided to elucidate underlying mechanisms from infection to the cancer, by *in vitro* and *in vivo* studies. First, we tried to identify responsible molecules for inflammation.

In vitro We revealed *H. pylori* induces strong NF- κ B signals, and these are by molecules in Cag pathogenicity island, 40kb segment of 1.5 million nucleotides (Gastroenterology 2000;119:97-108, J Biol Chem 2001;276:44856-44864).

In vivo To extrapolate this to *in vivo* system, we constructed isogenic mutant (knock out bacteria), lacking Cag gene molecules, and infected it to Mongolian gerbils (unique animal model). It turned out among Cag island, Cag E gene is the one responsible for strong induction of inflammation, whereas Vac A, claimed to be inflammation inducing molecule, is not (J Exp Med 2000;192:1601-1609). These CagE molecule of *H. pylori* gene is generally present in Japanese isolates, whereas it is often absent in European (Gut 1998;42:338-343). These may explain the difference of incidence of the gastric cancer among different countries.

Recently, Kawakami and Tateishi further elucidated that I κ B α , a key molecule in NF- κ B signal cascade,

was regulated by NEDD8 pathway activating ubiquitin-proteasome degradation system (EMBO J 2001;20:4003-4012, J Cell Biol 2001;155:571-579).

Although the NF- κ B signaling is extremely important as an inflammation inducing pathway, mechanism of direct effect on cell proliferation by *H. pylori* is not known. Hirata recently elucidated that CagA protein strongly activates SRE (Serum Response Element) which might be operating in the formation of polyp and even MALT lymphoma (Gastroenterology 2002; in press).

Our search for *effector protein* to induce signaling cascades has now began (J Exp Med 2000;191:593-602); it may help to eventually elucidate the molecular mechanism of gastric cancer.

4. Colon Cancer

Colonic cancer is catching up with the leading gastric cancer. Shift from Japanese to "Westernized" food may be responsible for this increase. However, we believe there is another reason. We have noticed right sided (cecum and ascending) colon cancer is increasing among patients over age 70 (60% vs 20% in ages over 70 and under 40, respectively) (Gastrointest Endosc 2002;55:548-551). We found the majority of the right sided colon cancer carried microsatellite instability (Cancer Res 1996;56:5620-5623). Now in Japan, average life expectancy for female and male is 85 and 78, respectively, longest ever.

We have initiated genome-wide screening of the genes having dinucleotide repeat or poly-A stretches, targets of repair gene errors.

5. Pancreatic Cancer

Once pancreatic cancer developed, median survival was only 200 days. Although we tried to employ K-ras gene mutation, which is found in 90% of the cancer, for early diagnosis (Gastroenterology 1991;100:233-238, 1996;110:227-231), it has been far from giving benefit to patients.

We have struggled to find better way of treatment and finally decided to apply allogenic stem cell transplantation by collaboration with Department of Hematology and Oncology. So far 5 patients enrolled and results are pending.

Current Research and Clinical Activities

1. Eradication of HBV

As I wrote, the ultimate goal of HBV treatment is not mere suppression which is currently available, but eradication of the virus (Treatment of chronic hepatitis B infection -Editorial N Engl J Med 1998 ; 339:114-115). To attain this goal we are undertaking the following :

HBV has two replication pathways, episomal (N Engl J Med 1986;315:1187-1192) and integrated form into human genome which presumably resist the treatment. We are now intensively focusing our study on the integrated form by use of post-sequencing information on human genome.

2. Eradication of HCV

We could eradicate the virus in more than 90% of acute hepatitis cases as was shown by us (Lancet 1991;338:914-915). However, only 30% in chronic hepatitis. To increase treatment efficacy, we now have *Replicon* system which allows us to grow treatment-resistant strains and to test drug candidates.

3. Liver Injury Mechanisms

Sequencing of extreme small amount of peptides is now feasible by high quality mass spectrometry. We are now analyzing HLA-related wild and mutants virus-derived peptides from human liver. This may identify the target of lymphocyte attack.

4. Prevention and Cure of HCC

We have treated 1,600 cases of HCC so far. We have shown that treatment of virus infection could prevent HCC. However, advanced HCC is still difficult to treat. We found that Vitamin K could efficiently prevent portal tumor invasion, once developed 100% fatal in one year. Along with other modalities, we might expect long-term survival in the majority of the patients with HCC.

5. Gastric Injury Mechanisms

Discovery of *H. pylori* protein in host cell, phosphorylated CagA protein (J Exp Med 2000;191:593-602), has prompted us to further search the *effector protein*, which could trigger signaling cascades. We have now several candidates.

6. Right-sided Colon Carcinogenesis

As I mentioned, repair-gene system seems deeply involved in the right-sided colon cancer, a prototype is, of course, HNPCC (Hereditary Nonpolyposis Colon Cancer). The understanding may help for people in the country where longest life-expectancy expected.

7. Pancreatic Cancer

We have initiated a large scale genome-wide SNP (Single Nucleotide Polymorphism) analysis to find high risk group.

Others Activities

In 5 years, we presented 121 papers in DDW (Digestive Disease Week, USA), the largest gastroenterology congress.

In 5 years, we published 320 papers in peer review journal.

In 5 years, 52 invited lectures were given in international meetings by one of us (M Omata).

Future Prospective

Education for medical students and for young physicians is the far most important mission of our department for the future. Our department have to cover multiple organs with diverse diseases. Thus, we are trying not to restrict their interest to one specialized field, but rather to introduce general technology and ideas. It will definitely become more "borderless" in post-genome era.

Research Grants

The Organization for Pharmaceutical Safety Research 1997-2001 (Total ¥346,000,000.)

Comprehensive 10-year Strategy for Cancer Control from Ministry of Health and Welfare, Health Sciences Research Grants 1994-1999 (Total ¥100,600,000.)

Medical Frontier Strategy Research from Ministry of Health Labor and Welfare, Health Sciences Research Grants 2001-2003 (2001 / ¥48,000,000.)

Grants-in-aid for Scientific Research on Priority Area from the Ministry of Education, Culture, Sports, Science and Technology of Japan 2000-2003 (Total ¥71,800,000.)

Grants-in-aid for Scientific Research (A) from the Ministry of Education, Culture, Sports, Science and Technology of Japan 2001-2004 (Total ¥40,300,000.)

Select Publications (50)

Hepatology

1. Omata M, Ehata T, Yokosuka O, Hosoda K, Ohto M. Mutations in the precore region of hepatitis B virus DNA in patients with fulminant and severe hepatitis. *N Engl J Med* 324 : 1699-1704, 1991.
2. Omata M, Yokosuka O, Takano S, Kato N, Hosoda K, Imazeki F, Tada M, Ito Y, Ohto M. Resolution of acute hepatitis C after therapy with natural beta interferon. *Lancet* 338 : 914-915, 1991.
3. Ehata T, Omata M, Yokosuka O, Hosoda K, Ohto M. Variations in codon 84-101 in the core nucleotide sequence correlate with hepatocellular injury in chronic hepatitis B virus infection. *J Clin Invest* 89 : 332-338, 1992.
4. Hosoda K, Omata M, Yokosuka O, Kato N, Ohto M. Nucleotide sequences of 5'-1-1 of hepatitis C virus in patients with chronic liver disease. *Gastroenterology* 102 : 1039-1043, 1992.
5. Chien DY, Choo QL, Tabrizi A, Kuo C, McFarland J, Berger K, Lee C, Shuster JR, Nguyen T, Moyer DL, Tong M, Furuta S, Omata M, Tegtmeyer G, Alter H, Schiff E, Jeffers L, Houghton M, Kuo G. Diagnosis of hepatitis C virus (HCV) infection using an immunodominant chimeric polyprotein to capture circulating antibodies : reevaluation of the role of HCV in liver disease. *Proc Natl Acad Sci USA* 89 : 10011-10015, 1992.
6. Ehata T, Omata M, Chuang WL, Yokosuka O, Ito Y, Hosoda K, Ohto M. Mutations in core nucleotide sequence of hepatitis B virus correlate with fulminant and severe hepatitis. *J Clin Invest* 91 : 1206-1213, 1993.
7. Chuang WL, Omata M, Ehata T, Yokosuka O, Ito Y, Imazeki F, Lu SN, Chang WY, Ohto M. Precore mutations and core clustering mutations in chronic hepatitis B virus infection. *Gastroenterology* 104 : 263-271, 1993.
8. Takano S, Satomura Y, Omata M, Japan Acute Hepatitis Cooperative Study Group. Effects of interferon beta on Non-A, Non-B acute hepatitis: A prospective, randomized, controlled-dose study. *Gastroenterology* 107 : 805-811, 1994.
9. Takano S, Yokosuka O, Imazeki F, Tagawa M, Omata M. Incidence of hepatocellular carcinoma in chronic hepatitis B and C : A prospective study of 251 patients. *Hepatology* 21 : 650-655, 1995.
10. Matsumoto A, Ogura K, Hirata Y, Kakoki M, Watanabe F, Takenaka K, Shiratori Y, Momomura S, Omata M. Increased nitric oxide in the exhaled air of patients with decompensated liver cirrhosis. *Ann Intern Med* 123 : 110-113, 1995.
11. Shiratori Y, Shiina S, Imamura M, Kato N, Kanai F, Okudaira T, Teratani T, Tohgo G, Toda N, Ohashi M, Ogura K, Niwa Y, Kawabe T, Omata M. Characteristic difference of hepatocellular carcinoma between hepatitis-B and -C viral infection in Japan. *Hepatology* 22 : 1027-1033, 1995.
12. Kanai F, Lan KH., Shiratori Y, Tanaka T, Ohashi M, Okudaira T, Yoshida Y, Wakimoto H, Hamada H, Nakabayashi H, Tamaoki T, Omata M. In vivo gene therapy for alpha-fetoprotein-producing hepatocellular carcinoma by adenovirus-mediated transfer of cytosine deaminase gene. *Cancer Res* 57 : 461-465, 1997.
13. Shiratori Y, Kato N, Yokosuka O, Imazeki F, Hashimoto E, Hayashi N, Nakamura A, Asada M, Kuroda H, Tanaka N, Arakawa Y, Omata M. Predictors of the efficacy of interferon therapy in chronic hepatitis C virus infection. *Gastroenterology* 113 : 558-566, 1997.
14. Kojima H, Yokosuka O, Imazeki F, Saisho H, Omata M. Telomerase activity and telomere length in hepatocellular carcinoma and chronic liver disease. *Gastroenterology* 112 : 493-500, 1997.
15. Omata M. Treatment of chronic hepatitis B infection (Editorial). *N Engl J Med* 339 : 114-115, 1998.
16. Ono-Nita SK, Kato N, Shiratori Y, Lan KH, Yoshida H, Carrilho FJ, Omata M. Susceptibility of lamivu-

- dine-resistant hepatitis B virus to other reverse transcriptase inhibitors. *J Clin Invest* 103 : 1635-1640, 1999.
17. Yoshida H, Shiratori Y, Moriyama M, Arakawa Y, Ide T, Sata M, Inoue O, Yano M, Tanaka M, Fujiyama S, Nishiguchi S, Kuroki T, Imazeki F, Yokosuka O, Kinoyama S, Yamada G, Omata M. Interferon therapy reduces the risk for hepatocellular carcinoma : National surveillance program of cirrhotic and non-cirrhotic patients with chronic hepatitis C in Japan. *Ann Intern Med* 131 : 174-181, 1999.
 18. Shiratori Y, Imazeki F, Moriyama M, Yano M, Arakawa Y, Yokosuka O, Kuroki T, Nishiguchi S, Sata M, Yamada G, Fujiyama S, Yoshida H, Omata M. Histologic improvement of fibrosis in patients with hepatitis C who have sustained response to interferon therapy. *Ann Intern Med* 132 : 517-524, 2000.
 19. Kato N, Yoshida H, Ono-Nita SK, Kato J, Goto T, Otsuka M, Lan KH, Matsushima K, Shiratori Y, Omata M. Activation of intracellular signaling by hepatitis B and C viruses: C-viral core is the most potent signal inducer. *Hepatology* 32 : 405-412, 2000.
 20. Otsuka M, Kato N, Lan KH, Yoshida H, Kato J, Goto T, Shiratori Y, Omata M. Hepatitis C virus core protein enhances p53 function through augmentation of DNA binding affinity and transcriptional ability. *J Biol Chem* 275 : 34122-34130, 2000.
 21. Goto T, Kato N, Ono-Nita SK, Yoshida H, Otsuka M, Shiratori Y, Omata M. Large isoform of hepatitis delta antigen activates serum response factor-associated transcription. *J Biol Chem* 275 : 37311-37316, 2000.
 22. Koike Y, Shiratori Y, Sato S, Obi S, Teratani T, Imamura M, Yoshida H, Shiina S, Omata M. Des-r-carboxy prothrombin as a useful predisposing factor for the development of portal venous invasion in patients hepatocellular carcinoma -a prospective analysis of 277 patients-. *Cancer* 91 : 561-569, 2001.
 23. Ono-Nita SK, Kato N, Shiratori Y, Kato J, Goto T, Schinazi RF, Carrillo FJ, Omata M. The polymerase L528M mutation cooperates with nucleotide binding-site mutations, increasing hepatitis B virus replication and drug resistance. *J Clin Invest* 107 : 449-455, 2001.
 24. Yoshida H, Kato N, Shiratori Y, Otsuka M, Maeda S, Kato J, Omata M. Hepatitis C virus core protein activates nuclear factor κ B-dependent signaling through tumor necrosis factor receptor-associated factor. *J Biol Chem* 276 : 16399-16405, 2001.
 25. Yoshida H, Arakawa Y, Sata M, Nishiguchi S, Yano M, Fujiyama S, Yamada G, Yokosuka O, Shiratori Y, Omata M. Interferon therapy prolonged life expectancy among chronic hepatitis C patients. *Gastroenterology* 123 : 483-491, 2002.
 26. Lan KH, Sheu ML, Hwang SJ, Yen SH, Chen SY, Wu JC, Wang YJ, Kato N, Omata M, Chang FY, Lee SD. HCV NS5A interacts with p53 and inhibits p53-mediated apoptosis. *Oncogene* 21 : 4801-4811, 2002.
 27. Shiratori Y, Shiina S, Teratani T, Imamura M, Obi S, Sato S, Koike Y, Yoshida H, Omata M. Interferon therapy after tumor ablation improves prognosis in patients with hepatitis C viral hepatocellular carcinoma. *Ann Intern Med* 2002 (in press).
- ### Gastroenterology
28. Tada M, Omata M, Ohto M. Clinical application of ras-gene mutation for diagnosis of pancreatic adenocarcinoma. *Gastroenterology* 100 : 233-238, 1991.
 29. Tada M, Omata M, Kawai S, Saisho H, Ohto M, Saiki R, Sninsky J. Detection of ras gene mutations in pancreatic juice and peripheral blood of patients with pancreatic adenocarcinoma. *Cancer Res* 53 : 2472-2474, 1993
 30. Ohta S, Yoshiura K, Takahashi M, Hata Y, Kohmoto O, Kawabe T, Shimada T, Hiraishi H, Mutoh H, Terano A, Sugimoto T, Omata M. P2 purinergic receptor regulation of mucus glycoprotein by rabbit gastric mucous cells in a primary culture. *Gastroenterology* 106 : 1485-1492, 1994.
 31. Shimada T, Ogura K, Ota S, Terano A, Takahashi M, Hamada E, Omata M, Sumino S, Sassa R. Identification of helicobacter pylori in gastric specimens, gastric juice, saliva and faeces of Japanese patients. *Lancet* 343 : 1636-1637, 1994.
 32. Takahashi M, Ota S, Shimada T, Hamada E, Kawabe T, Okudaira T, Matsumura M, Kaneko N, Terano A, Nakamura T, Omata M. Hepatocyte growth factor is the most potent endogenous stimulant of rabbit gastric epithelial cell proliferation and migration in primary culture. *J Clin Invest* 95 : 1994-2003, 1995.
 33. Tada M, Ohashi M, Shiratori Y, Okudaira T, Komatsu Y, Kawabe T, Yoshida H, Machinami R, Kishi K, Omata M. Analysis of K-ras gene mutation in hyperplastic duct cells of the pancreas without pancreatic disease. *Gastroenterology* 110 : 227-231, 1996.
 34. Imazeki F, Yokosuka O, Yamaguchi T, Ohto M, Isono K, Omata M. Expression of variant CD44-messenger RNA in colorectal adenocarcinomas and adenomatous polyps in humans. *Gastroenterology* 110 : 362-368, 1996.
 35. Lan KH, Kanai F, Shiratori Y, Okabe S, Yoshida Y, Wakimoto H, Hamada H, Tanaka T, Ohashi M, Omata M. Tumor-specific gene expression in carcinoma-embryonic antigen-producing gastric cancer cells using adenovirus vectors. *Gastroenterology* 111 : 1241-1251, 1996.
 36. Togo G, Toda N, Kanai F, Kato N, Shiratori Y, Kishi K, Imazeki F, Makuuchi M, Omata M. A transforming growth factor beta type II receptor gene mutation common in sporadic cecum cancer with microsatellite instability. *Cancer Res* 56 : 5620-5623, 1996.
 37. Takahashi M, Ota S, Hata Y, Mikami Y, Azuma N, Nakamura T, Terano A, Omata M. Hepatocyte growth factor as a key to modulate anti-ulcer action of prostaglandins in stomach. *J Clin Invest* 98 : 2604-2611, 1996.
 38. Lan KH, Kanai F, Shiratori Y, Ohashi M, Tanaka T, Okudaira T, Yoshida Y, Hamada H, Omata M. In

- vivo selective gene expression and therapy mediated by adenoviral vectors for human carcinoembryonic antigen-producing gastric carcinoma. *Cancer Res* 57 : 4279-4284, 1997.
39. Maeda S, Ogura K, Yoshida H, Kanai F, Ikenoue T, Kato N, Shiratori Y, Omata M. Major virulence factors, VacA and CagA, are commonly positive in *Helicobacter pylori* isolates in Japan. *Gut* 42 : 338-343, 1998.
 40. Maeda S, Yoshida H, Ikenoue T, Ogura K, Kanai F, Kato N, Shiratori Y, Omata M. Structure of cag pathogenicity island in Japanese *Helicobacter pylori* isolates. *Gut* 44 : 336-341, 1999.
 41. Asahi M, Azuma T, Ito S, Ito Y, Suto H, Nagai Y, Tsubokawa M, Tohyama Y, Maeda S, Omata M, Suzuki T, Sasakawa C. *Helicobacter pylori* Cag A protein can be tyrosine phosphorylated in gastric epithelial cells. *J Exp Med* 191 : 593-602, 2000.
 42. Maeda S, Yoshida H, Ogura K, Mitsuno Y, Hirata Y, Yamaji Y, Akanuma M, Shiratori Y, Omata M. *H. pylori* activates NF- κ B through a signaling pathway involving I κ B kinases, NF- κ B-inducing kinase, TRAF2, and TRAF6 in gastric cancer cells. *Gastroenterology* 119 : 97-108, 2000.
 43. Ogura K, Maeda S, Nakao M, Watanabe T, Tada M, Kyutoku T, Yoshida H, Shiratori Y, Omata M. Virulence factors of *Helicobacter pylori* responsible for gastric diseases in Mongolian gerbil. *J Exp Med* 192 : 1601-1609, 2000.
 44. Kawakami T, Chiba T, Suzuki T, Iwai K, Yamanaka K, Minato N, Suzuki H, Shimbara N, Hidaka Y, Osaka F, Omata M, Tanaka K. NEDD8 recruits E2-ubiquitin to SCF E3 ligase. *EMBO J* 20 : 4003-4012, 2001.
 45. Matsuhashi N, Watanabe K, Kanamori H, Ohnishi S, Omata M. PPAR γ agonists for intestinal ischaemia. *Lancet* 358 :75-76, 2001.
 46. Mitsuno Y, Yoshida H, Maeda S, Ogura K, Hirata Y, Kawabe T, Shiratori Y, Omata M. *Helicobacter pylori* induced transactivation of SRE and AP-1 through the ERK signalling pathway in gastric cancer cells. *Gut* 49 :18-22, 2001.
 47. Tateishi K, Omata M, Tanaka K, Chiba T. The NEDD8 system is essential for cell cycle progression and morphogenetic pathway in mice. *J Cell Biol* 155 : 571-579, 2001.
 48. Maeda S, Akanuma M, Mitsuno Y, Hirata Y, Ogura K, Yoshida H, Shiratori Y, Omata M. Distinct mechanism of *Helicobacter pylori*-mediated NF-kappa B activation between gastric cancer cells and monocytic cells. *J Biol Chem* 276 : 44856-44864, 2001.
 49. Okamoto M, Shiratori Y, Yamaji Y, Kato J, Ikenoue T, Togo G, Yoshida H, Kawabe T, Omata M. Relationship between age and site of colorectal cancer based on colonoscopy findings. *Gastrointest Endosc* 55 : 548-551, 2002.
 50. Hirata Y, Maeda S, Mitsuno Y, Akanuma M, Yanai A, Yoshida H, Kawabe T, Shiratori Y, Omata M. *H. pylori* CagA protein activates serum response element driven transcription independently of tyrosine phosphorylation. *Gastroenterology* 2002 (in press).

Insulin resistance has been suggested to play an important role in hypertension and the related organ damages. Thus, we also focused on insulin resistance in several model animals of hypertension. Interestingly, salt loading itself enhanced insulin resistance in normotensive rats. Certainly, salt-induced rise in blood pressure in Dahl salt-sensitive and angiotensin II (AII)-treated rats was accompanied with enhanced insulin resistance. The increased insulin resistance in hypertensive models is intimately related to oxidative stress. Interestingly, aged AM deficient mice showed insulin resistance, associated with overproduction of oxidative stress. Then, this is the model of insulin resistance syndrome, so-called "syndrome X".

Oxidized low density lipoprotein (OxLDL) has been implicated in pathophysiology of atherosclerosis. OxLDL alters endothelial function and triggered atherogenic changes. Thus, we focused on a novel endothelial OxLDL receptor, lectin-like OxLDL receptor-1 (LOX-1). We observed that LOX-1 was enhanced in aortas and kidneys of rats with hypertension, diabetes, and renal failure. Also, LOX-1 was stimulated by oxidative stress, which is known to cause organ damages by common diseases. The expression of LOX-1 was intimately related to nuclear factor (NF)- κ B. Thus, LOX-1 was implicated in pathophysiology of atherosclerosis and glomerulosclerosis via oxidative stress.

To elucidate a novel candidate gene for salt sensitivity of blood pressure, we performed differential display assay between Dahl salt-sensitive (DS) and -resistant (DR) rats. As a result, we found REPT1 (rat retrovirus-like element transcribed in proximal tubulus) in the kidneys of DS rats. REPT1 was located in the proximal tubules and its renal expression was correlated with salt sensitivity among different strains of rats.

Intracellular calcium ion (Ca^{2+}) is a spatially and temporally organized second messenger, which mediates a variety of important functions of vascular endothelial cells ranging from the production of vasoactive substances to gene expression. We developed FRET-based technique to image localized Ca^{2+} signaling in live endothelial cells. And, we succeeded to elucidate localized Ca^{2+} signaling and function of caveolae. Endothelial nitric oxide (NO) was localized in caveolae and activity of NO was regulated by intracellular Ca^{2+} and binding to caveolae.

G proteins control a diverse network of signals. We have focused on mutation of G proteins in human diseases. We have discovered how point mutations in α_s (the α subunits of G_s) alter G_s signaling, causing human diseases. Also, we succeeded in building up a simple cell-free method to study interaction between receptors and G proteins. We have, for the first time,

achieved success in designing dominant negative mutant $G\alpha$ proteins in realistic level. Also, we analyzed relationship of C825T polymorphism of $G\beta_3$ to hypertension, which has been demonstrated in Caucasian people.

We revealed that ionic mechanisms such as activation of inwardly-rectifying potassium currents and activation of nonselective cation currents are important in the regulation of hormone secretion from pituitary cells using electrophysiological techniques. Also, we elucidated the mechanisms of action of regulators of circulation system such as AM, proadrenomedullin N-terminal 20 peptide (PAMP), and AII. In addition, we studied mineralocorticoid action in pathophysiology of cardiovascular diseases.

We studied molecular basis for diseases of calcium (Ca^{2+}) metabolism. For example, we have identified novel mutations in Ca-sensing receptor gene in patients with Type II Bartter's syndrome as well as those with familial hypocalciuric hypercalcemia (FHH). Also, we characterized proteoglycans synthesized by osteoblasts biochemically and explored in detail cell-matrix interactions in osteoblasts. In addition, we identified negative Ca^{2+} responsive element (nCaRE) in the parathyroid hormone (PTH) gene.

From a physiological standpoint, we elucidated the basic transport properties of sodium-bicarbonate ($\text{Na}^+\text{-HCO}_3^-$) cotransport (NBC1) in renal proximal tubular acidosis (RTA) with ocular abnormalities. This is an example of a successful translation of basic finding into clinical medicine. We clarified the regulatory mechanism of proximal transport in physiological and pathological states and demonstrated the cAMP-activated chloride (Cl^-) conductance in proximal tubules. We revealed the immunohistochemical localization and function of Kir 7.1 potassium channel, organic anion transporter (OAT1), and stanniocalcin in the rat kidney. We cloned the Na^+/H^+ antiporter (NHE) cDNAs from human tissues and characterized the regulation of the expression of NHE in kidney cells.

With the application to acute renal failure or graft survival in mind, we demonstrated the successful intervention by cyclic RGD (Arg-Gly-Asp) peptide to reduce the renal ischemia-reperfusion model and the diagnostic utilities of monitoring the radio-labeled RGD peptides. We demonstrated the incorporation of oligonucleotides to proximal tubular epithelial cells and the amelioration of renal ischemia-reperfusion injury using antisense oligonucleotides specifically targeted to inducible NO synthase (NOS). We showed by *in vivo* approach the chemotactic activity of leukotriene B4 to drive neutrophil in acute ischemia-reperfusion injury.

The clarification of the mechanism of the progressive renal disease is the major problem to be solved in the field of nephrology. We contribute much to the

solution of immunological mechanism involved in glomerulonephritis, especially in terms of complement and complement regulatory proteins. We revealed the localization of NOS and NAD(P)H oxidase isoforms in the kidney and gave insight into the functional role of NO and oxidative stress in the kidney of hypertension, glomerulonephritis, and diabetes. We examined the role of physical factors such as mechanical stretch on TGF- β and extracellular matrix accumulation in the progression of renal disease. We demonstrated that renoprotective C-type natriuretic peptide was produced in renal parenchymal cells.

We isolated several transcription factors from vascular myocytes such as an isoform of MEF2A and GATA-6 and identified the implication of these factors in the differentiation or dedifferentiation of vascular myocytes and vascular hypertrophy process. We clarified the intracellular pathway involved in the cell cycle progression with endothelin-1 proved to promote the renal injury.

As a new technique, we developed a simple and reliable method of quantitating mRNAs in minute tissue samples in addition to the established microdissection and single transduction mechanism by which vasopressin and prostaglandins interact in the kidney using immunodissected tubule. We also developed a novel animal model of glomerular endothelial injury, which may help elucidate the mechanism of glomerular endothelial damage.

Research on renal regeneration has just started to do the identification of adult stem cells in the kidney. Using a flow cytometry assay and Hoechst 33342 staining, we isolated adult stem cells in the kidney as side population (SP) cells that have been identified as stem cells in bone marrow, skeletal muscle and liver. Using 3 dimensional culture systems, moreover, cultured renal SP cells differentiate into various kinds of cells.

Troughout our research we have attempted to link our basic finding with our clinical work----between bench and bedside with either direction.

Current Research

To extent our past accomplishment further, we are now attempting to clarify the following themes.

Recent studies have revealed that oxidative stress is intimately related to not only hypertension but also the other common disease such as diabetes and hypercholesterolemia, so we are examining whether these abnormalities including insulin resistance develop AM^{+/-} mice, in which oxidative stress is enhanced. Also, we are investigating the effect of hypoxia in AM^{+/-} mice, because hypoxia-induced damage is known to relate to oxidative stress.

To elucidate atherogenic role of LOX-1, we are studying whether atherogenic stimuli such as AII infusion and cuff injury cause severe vascular damages in LOX-1 transgenic mice. Moreover, we found that peroxisome proliferator-activated receptor γ (PPAR γ) ligands inhibit cytokine-stimulated LOX-1 expression *in vitro* and *in vivo*. Now we are studying this mechanism, which may suggest that the inhibition of LOX-1 might be related to antiatherogenic effect of PPAR γ ligands.

We developed FRET-based tool to image subplasmalemmal Ca²⁺ and cAMP. We are now studying role of caveolin scaffolding domain and hsp90 on NO production using unique cell biological and imaging techniques.

By the cell-free method to study interaction between receptors and G proteins, we studied the specificity between many G proteins and G protein-coupled receptors for cardiovascular hormones, such as AII, catecholamines, and AM.

We are studying the central role of Ca-sensing receptor in salt-sensitive hypertensive model animal, in which Ca loading ameliorated hypertension. Moreover, we have many themes such as electrophysiology of pituitary, signal transduction of mineralocorticoid receptor, mechanisms of age-related osteopenia, and so on.

We further clarify molecular mechanism of proximal RTA based on newly identified NBC1 mutation. The molecular basis of ion transport in NBC1 is studying via giant patch technique.

We are studying roles of lipid mediators in renal ischemia-reperfusion injury using several lines of mice deleted/overexpressed lipid mediator genes. We are analyzing detailed intracellular pathways implicated in the expression of monocyte chemoattractant protein-1 in vascular myocytes.

We are investigating role of endogenous vasoactive substances in the progression of renal diseases such as AII, AM, leukotriene, retinoid and glucocorticoids using knockout mice and renal cells. We are also studying roles of oxidative and nitrosoactive stress in the renal diseases including diabetic nephropathy, ischemia-reperfusion injury, and long-term hemodialysis complications.

Now 3 projects of renal regeneration are on going. First, optimizing the 3 dimensional culture systems to differentiate renal SP cells to metanephros. Second, clarifying the condition and identifying the morphogen to differentiate human adult stem cells such as bone marrow derived mesenchymal stem cells into renal components. Third, investigating the existence of stem cell dysfunction in patients with renal dysfunction, and getting comprehensive information for intervention using DNA microarray analysis.

Future Prospects

The main goal of our studies is to cure patients with renal and endocrinological diseases and hypertension to reduce the number of patients with hypertensive complications and renal failure. To serve this purpose, we have to focus our effort to clarify the mechanisms of diseases. There are not only numerous diseases in our field but also multiple mechanisms to involved especially in chronic stage of renal failure and cardiovascular complication-associated hypertension. Thus, we are applying the multi-dimensional approach such as oxidative stress, lipid metabolism, hemodynamics, and vasoactive substances. These approaches will lead to the development of several new drugs and strategies to treat renal and endocrinological diseases, hypertension, and its complications. By the discoveries of the candidate genes for salt-sensitive hypertension, we can try to choose the suitable antihypertensive therapy and salt restriction for individual patients (tailor-made medicine).

Research Grants

1. Toshiro Fujita: 1998-2002 Grant-in-aid for scientific research from the Ministry of Education, Culture, Sports, Science and Technology of Japan (specific field): Molecular biological and embryological investigation of adrenomedullin, 54,500,000 yen
2. Toshiro Fujita: 2000-2002 Grant-in-aid for scientific research from the Ministry of Education, Culture, Sports, Science and Technology of Japan (B) Role of oxidized LDL/lectin-like oxidized LDL receptor-1 (LOX-1) system in the development of glomerulosclerosis. 15,000,000 yen
3. Atsuo Goto: 1995-1997 Grant-in-aid for scientific research from the Ministry of Education, Culture, Sports, Science and Technology of Japan (B) Role of endogenous digitalis-like substance in relationship between stress and cardiovascular diseases, 7,500,000 yen
4. Tomoki Okazaki: 1999-2001 Grant-in-aid for scientific research from the Ministry of Education, Culture, Sports, Science and Technology of Japan (B): The mechanism of transcriptional inhibition by nuclear hormone receptors by using a vitamin D receptor as a model, 14,000,000 yen
5. Taro Iiri (Assistant professor of endocrinology): 2002-2004 Grant-in-aid for scientific research from the Ministry of Education, Culture, Sports, Science and Technology of Japan (A): G protein and diseases: Analysis of molecular mechanism and regulation of signal transduction, 30,000,000 yen

Select Publications

1. Watanabe S, Fukumoto S, Chang H, Takeuchi Y, Hasegawa Y, Okazaki R, Chikatsu N, Fujita T:

- Association between activating mutations of calcium-sensing receptor and Bartter's syndrome. *Lancet*, 360:692-694, 2002
2. Ogihara T, Asano T, Ando K, Sakoda H, Anai M, Shojima N, Ono H, Onishi Y, Fujimoto M, Abe M, Fukushima Y, Kikuchi M, Fujita T: High-Salt Diet Enhances Insulin Signaling and Induces Insulin Resistance in Dahl Salt-Sensitive Rats. *Hypertension*, 2002;40:83-89.
 3. Shimosawa T, Shibagaki Y, Ishibashi K, Kitamura K, Kangawa K, Kato S, Ando K, Fujita T: Adrenomedullin, an endogenous peptide, counteracts cardiovascular damage. *Circulation*. 105(1):106-111, 2002.
 4. Sun D, Seki G, Uwatoko S, Nakao A, Goto A, Fujita T, Kimura S, Taniguchi S: Quantifying porphobilinogen deaminase mRNA in microdissected nephron segments by a modified RT-PCR. *Kidney International* 61(1):336-41, 2002.
 5. Onozato ML, Tojo A, Goto A, Fujita T, Wilcox CS: Oxidative stress and nitric oxide synthase in rat diabetic nephropathy: effects of ACEI and ARB. *Kidney International*. 61(1):186-94, 2002.
 6. Chabrashvili T, Tojo A, Onozato M, Kitiyakara C, Quinn M, Fujita T, Welch W, Wilcox S: Expression and cellular localization of classic NADPH oxidase subunits in the spontaneously hypertensive rat kidney. *Hypertension* 39:269-274, 2002.
 7. Suzuki E, Nishimatsu H, Satonaka H, Walsh K, Goto A, Omata M, Fujita T: Angiotensin II induces myocyte enhancer factor 2- and calcineurin/nuclear factor of activated T cell-dependent transcriptional activation in vascular myocytes. *Circ Res*. 90:1004-1011, 2002.
 8. Usui T, Hara M, Satho H, Moriyama N, Kagaya H, Amano S, Oshita T, Ibaraki N, Hara C, Kunimi M, Norii E, Tsukamoto K, Inatomi J, Kawakami H, Endou H, Igarashi T, Goto A, Fujita T, Araie M: Molecular basis of ocular abnormalities associated with proximal renal tubular acidosis. *The Journal of Clinical Investigation*. 108:107-115, 2001.
 9. Chiba Y, Ogita T, Ando K, Fujita T: PPAR γ ligands inhibit TNF- α -induced LOX-1 expression in cultured endothelial cells. *Biochem Biophys Res Commun* 286: 541-546, 2001.
 10. Nagase M, Ando K, Nagase T, Kaname S, Sawamura T, Fujita T: Redox-sensitive regulation of LOX-1 gene expression in vascular endothelium. *Biochem Biophys Res Commun* 281: 720-725, 2001.
 11. Chang H, Fujita T: PicSNP: a browsable catalog of nonsynonymous single nucleotide polymorphisms in the human genome. *Biochem Biophys Res Commun* 287(1):288-91, 2001.
 12. Sogabe H, Nangaku M, Ishibashi Y, Wada T, Fujita T, Sun X, Miwa T, Madaio MP, Song WC: Increased susceptibility of decay-accelerating factor deficient mice to anti-glomerular basement membrane glomerulonephritis. *Journal of Immunology*. 167(5):2791-7, 2001.

13. Sekine N, Fukumoto S, Ishikawa T, Okazaki T, Fujita T: GH inhibits interferon-gamma-induced signal transducer and activator of transcription-1 activation and expression of the inducible isoform of nitric oxide synthase in INS-1 cells. *Endocrinology*. 142(9):3909-16, 2001.
14. Shao J, Miyata T, Yamada K, Hanafusa N, Wada T, Gordon KL, Inagi R, Kurokawa K, Fujita T, Johnson RJ, Nangaku M: Protective role of nitric oxide in a model of thrombotic microangiopathy in rats. *Journal of the American Society of Nephrology*. 12(10):2088-97, 2001.
15. Noiri E, Nakao A, Uchida K, Tsukahara H, Ohno M, Fujita T, Brodsky S, Goligorsky MS: Oxidative and nitrosative stress in acute renal ischemia: *American Journal of Physiology - Renal Fluid & Electrolyte Physiology*. 281(5):F948-57, 2001.
16. Watanabe S, Fukumoto S, Takeuchi Y, Fujita H, Nakano T, Fujita T: Effects of 1-year treatment with fluvastatin or pravastatin on bone. *American Journal of Medicine*. 110(7):584-7, 2001
17. Nagase M, Ando K, Nagase T, Kaname S, Sawamura T, Fujita T: Redox-sensitive regulation of lox-1 gene expression in vascular endothelium. *Biochem Biophys Res Commun* 281(3):720-5, 2001.
18. Kanda H, Kubo K, Hamasaki K, Kanda Y, Nakao A, Kitamura T, Fujita T, Yamamoto K, Mimura T: Influence of various hemodialysis membranes on the plasma (1 \rightarrow 3)-beta-D-glucan level. *Kidney International*. 60(1):319-23, 2001
19. Yamada K, Hori Y, Hanafusa N, Okuda T, Nagano N, Choi-Miura NH, Couser WG, Miyata T, Kurokawa K, Fujita T, Nangaku M: Clusterin is up-regulated in glomerular mesangial cells in complement-mediated injury. *Kidney International*. 59(1):137-46, 2001.
20. Suzuki J, Ohnishi H, Shibata H, Wada A, Hirayama T, Iiri T, Ueda N, Kanamaru C, Tsuchida T, Mashima H, Yasuda H, Fujita T: Dynamin is involved in human epithelial cell vacuolation caused by the *Helicobacter pylori*-produced cytotoxin VacA. *Journal of Clinical Investigation*. 107(3):363-70, 2001.
21. Kanamaru C, Yasuda H, Takeda M, Ueda N, Suzuki J, Tsuchida T, Mashima H, Ohnishi H, Fujita T: Smad7 is induced by norepinephrine and protects rat hepatocytes from activin A-induced growth inhibition. *Journal of Biological Chemistry*. 276(49):45636-41, 2001
22. Chang H, Fujita T: A numerical model of acid-base transport in rat distal tubule. *American Journal of Physiology - Renal Fluid & Electrolyte Physiology*. 281(2):F222-43, 2001.
23. Ishikawa T, Sekine N, Hata K, Igarashi T, Fujita T: Prostaglandin A₁ enhances *c-fos* expression and activating protein-1 activity. *Molecular and Cellular Endocrinology* 164:77-85, 2000.
24. Sekine N, Ishikawa T, Okazaki T, Hayashi M, Wollheim C.B., Fujita T: Synergistic activation of NF- κ B and inducible isoform of nitric oxide synthase induction by interferon- γ and tumor necrosis factor- α in INS-1 cells. *J. Cell Physiol*. 184:46-57, 2000.
25. Chikatsu N, Takeuchi Y, Tamura Y, Fukumoto S, Yano K, Tsuda E, Ogata E, Fujita T: Interactions between cancer and bone marrow cells induce osteoclast differentiation factor expression and osteoclast-like cell formation in vitro. *Biochem Biophys Res Commun* 267:632-637, 2000.
26. Noiri E, Yokomizo T, Nakao A, Izumi T, Fujita T, Kimura S, Shimizu T: An in vivo approach showing the chemotactic activity of leukotriene B₄ in acute renal ischemic-reperfusion injury. *Proc Natl Acad Sci*. 97:823-828, 2000.
27. Chikatsu N, Fukumoto S, Takeuchi Y, Suzawa M, Obara T, Matsumoto T, Fujita T: Cloning and characterization of two promoters for the human calcium-sensing receptor (CaSR) and changes of CaSR expression in parathyroid adenomas. *J Biol Chem* 275:7553-7557, 2000.
28. Kunimi M, Seki G, Hara C, Taniguchi S, Uwatoko S, Goto A, Kimura S, Fujita T: Dopamine inhibits renal Na⁺:HCO₃⁻ cotransporter in rabbits and normotensive rats but not in spontaneously hypertensive rats. *Kidney International* 57:534-543, 2000.
29. Kubota N, Terauchi Y, Miki H, Tamemoto H, Yamauchi T, Komeda K, Satoh S, Nakano R, Ishii C, Sugiyama T, Eto K, Tsubamoto Y, Okuno A, Murakami K, Sekihara H, Hasegawa G, Naito M, Toyoshima Y, Tanaka S, Shiota K, Kitamura T, Fujita T, Ezaki O, Aizawa S, Nagai R, Tobe K, Kimura S, and Kadowaki T.: PPAR γ mediates high-fat diet-induced adipocyte hypertrophy and insulin resistance. *Mol Cell*. 4:597-609, 1999.
30. Hori Y, Yamada K, Hanafusa N, Okuda T, Okada N, Miyata T, Couser W, Kurokawa K, Fujita T, Nangaku M: Crry, a complement regulatory protein, modulates renal interstitial disease induced by proteinuria. *Kidney International* 56:2096-2106, 1999.
31. Chang H, Fujita T: A kinetic model of the thiazide-sensitive Na-Cl cotransporter. *Am J Physiol* 276:F952-F959, 1999.
32. Chang H, Fujita T: A numerical model of the renal distal tubule. *Am J Physiol* 276:F931-F951, 1999.
33. Hayashi M, Shimosawa T, Fujita T: Hyperglycemia increases vascular adrenomedullin expression. *Biochem Biophys Res Commun* 258: 453-456, 1999.
34. Yasufuku-Takano J, Takano K, Takei T, Fukumoto S, Teramoto A, Takakura K, Yamashita N, Fujita T : Heterozygous *gsp* mutation renders ion channels of human somatotroph adenoma cells unresponsive to growth hormone-releasing hormone. *Endocrinology* 140: 2018-2026, 1999.
35. Suzuki Y, Itakura M, Kashiwagi M, Nakamura N, Matsuki T, Sakuta H, Naiyo N, Takano K, Fujita T, Hirose S: Identification by differential display of a hypertonicity-inducible inward rectifier potassium channel highly expressed in chloride cells. *J Biological Chem* 274: 11376-11382, 1999.
36. Suzawa M, Takeuchi Y, Fukumoto S, Kato S, Ueno N, Miyazono K, Matsumoto T, Fujita T: Extracellular matrix-associated bone morphogenetic proteins are

- essential for differentiation of murine osteoblastic cells in vitro. *Endocrinology* 140: 2125-2133, 1999.
37. Takano K, Fujita T : Proadrenomedullin N-terminal 20 peptide hyperpolarizes the membrane by activating an inwardly rectifying K^+ current in differentiated PC12 cells. *Circ Res.* 84:445-450,1999.
 38. Nagase M, Kato A, Ono T, Suzuki Y, Hirose S, Fujita T : Retrotransposons transcribed preferentially in proximal tubules of salt-hypertensive rats. *Kidney International* 55: 995-1004, 1999.
 39. Okazaki R, Chikatsu N, Nakatsu M, Kakeuchi Y, Ajima M, Miki J, Fujita T, Arai M, Totsuka Y, Tanaka K, Fukumoto S :A novel activating mutation in calcium-sensing receptor gene associated with a family of autosomal dominant hypocalcemia. *J Clin Endocrinol Metab* 84: 363-366,1999.
 40. Iiri T, Bell S.M., Baranski T.J., Fujita T, Bourne H.R. :A $G_{s\alpha}$ mutant designed to inhibit receptor signaling through G_s . *Proc Natl Acad Sci.* 96: 499-504, 1999.
 41. Iiri T, Bell S.M., Baranski T.J., Fujita T, Bourne H.R.: A $G_{s\alpha}$ mutant designed to inhibit receptor signaling through G_s . *Proc Natl Acad Sci.* 96: 499-504, 1999.
 42. Isshiki M, Ando J, Korenaga R, Kogo H, Fujimoto T, Fujita T, Kamiya A: Endothelial Ca^{2+} waves preferentially originate at specific loci in caveolin-rich cell edges. *Proc Natl Acad Sci* 95:5009-5014,1998.
 43. Nagase M, Abe J, Takahashi K, Ando J, Hirose S, Fujita T : Genomic organization and regulation of expression of the lectin-like oxidized low-density lipoprotein receptor(LOX-1) gene. *J Biological Chem* 273:33702-33707,1998.
 44. Hayashi M, Shimosawa T, Isaka M, Yamada S, Fujita R, Fujita T: Plasma adrenomedullin in diabetes. *Lancet* 350: 1449-1450, 1997.
 45. Nakaoka T, Gonda K, Ogita T, Otawara-Hamamoto Y, Okabe F, Kira Y, Harii K, Miyazono K, Takuwa Y, Fujita T: Inhibition of Rat Vascular Smooth Muscle Proliferation in Vitro and in Vivo by Bone Morphogenetic Protein-2. *J Clin Invest* 100: 2824-2832,1997.
 46. Takano K, Yasufuku-Takano J, Teramoto A, Fujita T: Corticotropin-releasing hormone excites adrenocorticotropin-secreting human pituitary adenoma cells by activating a nonselective cation current. *J Clin Invest* 98:2033-2041,1996.
 47. Takano K, Yamashita N, Fujita T: Proadrenomedullin NH₂-terminal 20 peptide inhibits the voltage-gated Ca^{2+} channel current through a pertussis toxin-sensitive G protein in rat pheochromocytoma-derived PC 12 cells. *J Clin Invest* 98:14-17,1996.
 48. Chung U, Tanaka Y, Fujita T: Association of Interleukin 6 and hypoaldosteronism in patients with cancer. *New Engl J Med* 334:473,1996.
 49. Shimosawa T, Ito Y, Ando K, Kitamura K, Kangawa K, Fujita T: Proadrenomedullin N-terminal 20 peptide, a new product of the adrenomedullin gene, inhibits norepinephrine overflow from nerve endings. *J Clin Invest* 96:1672-1676,1995.
 50. Kitagawa M, Chang H, Fujita T: Hyperkalemia due to nafamostat mesilate. *New Engl J Med* 332:687,1995

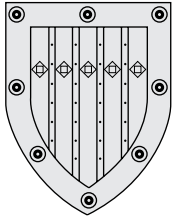

Department of Allergy and Rheumatology

Outline and Research Objectives

Our department was established in 1998 according to the reorganization of the Internal Medicine. Doctors from previous Department of Medicine and Physical therapy and the Third Department of Internal Medicine have joined our department. Our main clinical field are rheumatology and allergy. Therefore, our research fields also cover the areas including basic immunology, clinical immunology, rheumatology and allergy. Especially, an area called applied immunology such as developing new therapeutic methods has ready became important and some projects in these directions have thus been carried out in our department. Our Reumatology and Immunology field comprises several projects including T cell receptor, autoantibody, oral tolerance, cell signaling and genetic analysis. The allergy field comprises projects of airway inflammation and IgE response.

Faculties and Students

Professor and Chair Kazuhiko Yamamoto, M.D.
(Rheumatology, Allergology)1997

Lecturer Hirokazu Okudaira, M.D. (Allergology)
Fujio Takeuchi, M.D. (Rheumatology)
Yosikata Misaki, M.D. (Rheumatology)
Zen-ichiro Honda, M.D.(Rheumatology)

Associate8
 Postdoctoral Fellow7
 Graduate student16
 Research student.....2
 Secretary4

Past Research and Major Accomplishments

Rheumatology and Immunology

1. T Cell Receptor (TCR) Project

We have established a method for analyzing T-cell clonality using RT-PCR of TCR messages and subsequent electrophoretic separation of the PCR product based on their single strand conformation polymorphism (SSCP). Using this method an analysis of PBLs obtained from a healthy individual revealed the heterogeneity of the CDR3 region of the TCR beta messages. On the other hand, clonally accumulated T cells could be identified as distinct bands on the background heterogeneous electrophoretic patterns. With this method, we reported the importance of antigen-specific T cell clones in the pathogenesises of RA, SLE, other autoimmune diseases.

Having observed the importance of antigen-specific T cells in autoimmune disorders, we are now trying

to establish methods to generate regulatory T cells engineered by transfer of genes, the information of which could be obtained from an individual patient sample. At first, we generated an efficient alpha/beta TCR gene transfer system using two independent monocistronic retrovirus vectors. This system enabled us to express the clonotypic TCR in about 25-40% of the CD4+ T cells from murine splenocytes. The transduced cells showed an antigen-specific proliferation in vitro as well as an antigen-specific delayed-type hypersensitivity in vivo. Furthermore, regulatory T cells engineered by the transfer of collagen-specific TCR and IL-10 genes suppressed collagen induced arthritis in mice. In addition, nucleosome-specific T cells generated by the similar triple gene transfer of TCR and CTLA4Ig were applied to lupus-prone NZB/W F1 mice. These cells suppressed the related pathogenic autoantibody production and nephritis without impairing the T cell-dependent humoral immune responses. Thus, from these results, we could obtain efficient TCR function by gene transfer.

2. Autoantibody Project

We have been investigating in the regulatory mechanism of autoantibody production, which is the hallmark of systemic autoimmune diseases such as systemic lupus erythematosus. We generated a transgenic mice which expresses human U1snRNP-A autoantigen. We found that splenic T cells from this transgenic mice suppressed the immune response to human U1-A. In order to further examine the regulation of autoreactive T cell in a clone level, We also generated a transgenic mice expressing ovalbumin (OVA) systemically in nucleus. In the combination with OVA-specific T cell receptor transgenic mice, we

demonstrated that dendritic cells are able to tolerize autoreactive T cells. Furthermore, we found that self-reactive T cells matured into CD4(+)CD25(+) regulatory T cells in the thymus.

3. Oral Tolerance Project

We have studied the mechanism of tolerance induction in the mucosal immune system and its application to therapy of autoimmune diseases. Especially, we focused on the role of DC (dendritic cells) for oral tolerance after antigen feeding. We examined the requirement for tolerance induction in adoptive cell transfer system and found that not only T cells but DCs in Peyer's patches or spleen are important for the transfer of oral tolerance. We also fed OVA to Balb/c mice in bronchial asthma mouse model induced by OVA and confirmed that OVA feeding suppressed airway hyperactivity. In this system, depletion of DCs abrogated the transfer of tolerance.

4. Intracellular Signaling Project

Receptors Fc portion of Immunoglobulines play central roles in the initial step of immune regulation. For the cells to be activated, the receptors should be cross-linked by multivalent ligands. We have engaged in solving the mechanisms, in which physical receptor cross-linking is converted into biochemical signaling. It was assumed that receptor engagement is sensed and converted by Src family kinases (SFKs) to cell-inner events. However, the compensatory function of eight SFKs hampered clear demonstration of the notion. We introduced novel strategies to circumvent the difficulty, and established their requirement and specificity in Fc, and c-Kit and Integrin receptors. Notably, SFKs responsible for Fc receptor signaling are all modified with palmitic acid, and they reside in a membrane domain referred to as 'lipid rafts'.

On the other hand, we found that a 105 kDa molecule was tyrosine phosphorylated through TCR ligation in human T cells. It was proven to be p105^{CasL}, a member of the p130^{Cas}-related docking protein family, which subsequently binded to the Src homology 2 domain of c-Crk. We showed that it was also tyrosine phosphorylated through integrin stimulation in T cells, and its expression was predominant in lymphocytes. Next, we reported that Fyn and Lck tyrosine kinases regulated tyrosine phosphorylation of p105^{CasL} in TCR-mediated signaling in human T cells and splenocytes of lpr mice, SLE model mice.

5. Genetics Project

We have studied genetic background and pathophysiology of rheumatic diseases, and mechanisms and effect of aging were studied. Examples are

1) Genetic analysis of HLA-DRB1 shared epitope in RA family cases showed the participation of the epitope was neither unique nor indispensable.

2) Linkage analysis using a familial juvenile hyperuricemic nephropathy (FJHN) revealed the susceptibility region in chr16p12.

Allergy

1. Airway Inflammation Project

We established a system to evaluate antigen specific response of the airway in the mouse under a non-invasive, unrestrained condition. Using this system, we analyzed relationships among sensitization to an allergen, increase in airway hyperreactivity (AHR), and development of airway inflammation. The results demonstrated that contrary to the previous general understandings, AHR can be induced with systemic sensitization alone (early phase AHR).

We have also found that intratracheal administration of hepatocyte growth factor (HGF), a regenerative growth factor for bronchial and alveolar epithelial cells could attenuate extent of the experimental lung fibrosis. In addition, we elucidated the mechanism of action and found that HGF has a potent migratory activity and enhancing activity of surface fibrinolytic system of lung epithelial cells. Further, we reported that anti-fibrotic cytokine IFN- γ potentiates the biological activity of HGF by upregulating the expression of c-Met/HGF receptor on alveolar epithelial cells.

2. IgE Response Project

Surface expression of high affinity IgE receptor (FceRI) on mast cells is essential for these cells to exert IgE-dependent effector functions. We have analyzed how and to what extent mast cell surface FceRI expression is regulated, and whether regulation of their surface FceRI levels is functionally important. Through the series of our study, we found that the ligand of FceRI, IgE, which is known to stabilize FceRI, can greatly upregulate the surface FceRI levels on mast cells. A Th2 cytokine, IL-4, is also involved in FceRI upregulation in mast cells. Mast cells with upregulated levels of surface FceRI in the presence of IgE and/or IL-4 demonstrate enhancement in IgE-dependent mediator release and cytokine production. On the other hand, glucocorticoid, decreases the surface FceRI levels of mouse mast cells either in the presence or absence of IgE, via posttranscriptional mechanism. These results indicate that mast cell surface FceRI levels are regulated via multiple mechanisms by various factors including IgE, cytokines and glucocorticoids, resulting in functional alteration of mast cells. IgE- and FceRI-related positive feedback mechanism may account for the pathogenesis of IgE-mediated allergy.

Current Research

Rheumatology and Immunology

1. TCR Project

We are now trying to establish an efficient method to reconstitute TCR function using information available from a small sample of a patient. In order to accomplish these projects, two important technological breakthroughs are necessary. They are cloning techniques of full length cDNA encoding alpha and beta TCR from a single cells and efficient vectors to deliver these genes into usual lymphocytes. We are now trying to develop several possible technical improvements.

2. Autoantibody Project

We have identified several unique molecules to CD4(+)CD25(+) regulatory T cells including transcription factors and proliferation-associated molecules, which indicate that the subset is a unique and distinct population.

3. Oral Tolerance Project

We are studying the mechanisms of generation of regulatory T cells which mediate mucosal tolerance. We are visualizing the interaction between T cells and DCs which captured antigen in Peyer's patch and characterizing DCs which are involved in generation of regulatory T cells. We are also investigating a role of TGF- β for generation of regulatory cells in mucosal tolerance and for class switching of B cells to IgA secreting plasma cells.

4. Intracellular Signaling Project

We are searching for the molecules responsible for Fc receptor-mediated lipid raft assembly through protein chemistry approaches. We have also cloned two novel molecules interacting with a SFK, Lyn. One is an ubiquitin ligase with RING domain, presumably promoting SFK turnover. Another is a huge adaptor protein possessing putative Grb2 and PI3K binding sites and GAP domain.

We are also investigating whether IGF-I could prevent glomerulosclerosis, because glomerulosclerosis was not found in IGF-I overexpressing mice, although glomerulohypertrophy became obvious. To investigate this, we are evaluating the effects of adding IGF-I after adhesion stimulation on some signaling molecules in rat mesangial cells. Concurrently, we are preparing an animal study, using 5/6 nephrectomy as glomerulosclerosis model rat, to know whether IGF-I infusion prevents glomerulosclerosis.

5. Genetics Project

Some candidate gene analysis are now in progress

Allergy

1. Airway Inflammation Project

We have recently found that passive cell transfer of spleen cells obtained from sensitized mouse into naive mouse provokes an increase in the AHR. This indicates that mechanisms to induce AHR can be studied. We are now analyzing which kind of cell in the lung, such as antigen presenting cells, mast cells, and lymphocytes, would contribute to the development of early phase AHR by negative and positive selection of spleen cells.

2. IgE Response Project

We are interested whether IgE crosslinking stimulation of mast cells and basophils can result in cellular changes other than activation. Currently we are exploring the phenomenon of Fc ϵ RI-mediated desensitization. At present we think that cellular desensitization and stimulation may be separate but closely related to each other.

Future Prospects

Rheumatology and Immunology

1. TCR Project

Our final goal is to establish an antigen-specific immunotherapy in terms of TCR gene transfer using information from a small sample of an individual patient. Once the basic system is established, we could apply this to several different immunological disorders. Applicable disorders include rheumatoid arthritis, systemic lupus erythematosus and other connective tissue diseases, cancer patients, transplantation, severe infections such as AIDS and severe forms of allergy. We believe that this system would become one of fundamental methods in clinical immunology.

2. Autoantibody Project

We will clarify the generative mechanism of regulatory T cells generation and will innovate the methods to control the regulatory T cells.

3. Oral tolerance Project

Our purpose is to treat autoimmune diseases using the mechanism of tolerance induction by mucosal immune system.

4. Intracellular Signaling Project

Identification of the 'raft target' is unequivocally important for basic science and for therapeutic intervention of inflammatory diseases.

The pathological examination of end-stage renal disease shows similar glomerulosclerotic patterns,

although there are many causes of renal diseases. Therefore, we believe that preventing glomerulosclerosis could stop the progression to end-stage renal disease.

5. Genetics Project

Genes wide screen of several diseases would be expected.

Allergy

1. Airway Inflammation Project

We are expecting to establish a new strategy for preventing the development of AHR before onset of airway inflammation.

2. IgE Response Project

The aim of our study is to understand the pathogenesis and establish the new therapeutic strategy of IgE-mediated allergic diseases, such as bronchial asthma and allergic rhinitis, from which more people are suffering. Because IgE-mediated allergy seems much more complicated than previously thought, our future progress in this research area will be of substantial importance.

Research Grants

1. Research on Specific Diseases from the Ministry of Health and Welfare of Japan 1999-2001.
2. Research on Allergic disease and Immunology from the Ministry of Health, Labour and Welfare 2002-2004
3. Research on Health Sciences focusing on Drug Innovation from the Japan Health Sciences Foundation 2000-2002
4. Research on Eye and Ear Sciences, Immunology, Allergy and Organ Transplantation from the Ministry of Health and Welfare of Japan 1998-2000.
5. Research Grant from the Ministry of Education, Science, Sports and Culture of Japan(Kibann KenkyuA) 1999-2001

Select Publications

1. Kawahata K, Misaki Y, Yamaguchi M, Tsunekawa S, Setoguchi K, Miyazaki J and Yamamoto K. Peripheral tolerance to a nuclear autoantigen:dendritic cells expressing a nuclear autoantigen lead to persistent anergic state of CD4 autoreactive T cells after proliferation. *J Immunol.*168:1103-1112, 2002.
2. Nagase H, Miyamasu M, Yamaguchi M, Imanishi M, Tsuno NH, Matsushima K, Yamamoto K, Morita Y and Hirai K. Cytokine-mediated regulation of CXCR4 expression in human neutrophils. *J Leukocyte Biol.*71:711-717, 2002.

3. Yoshimura C, Yamaguchi M, Iikura M, Izumi S, Kudo K, Nagase H, Ishii A, Wall AF, Ra C, Iwata T, Igarashi T, Yamamoto K and Hirai K. Activation makers of human basophils:CD69 expression is strongly and preferentially induced by IL-3. *J Allergy Clin Immunol.*109:817-823, 2002.
4. Kawahata K, Misaki Y, Yamauchi M, Tsunekawa S, Setoguchi K, Miyazaki J and Yamamoto K. Generation of CD4⁺CD25⁺ regulatory T cells from autoreactive T cells simultaneously with their negative selection in the thymus and from non-autoreactive T cells by endogenous T cell receptor expression. *J Immunol.* 68:4399-405, 2002.
5. Kono H, Suzuki T, Yamamoto K, Okada M, Yamamoto T and Honda Z. Spatial raft coalescence represents an initial step in Fc gamma R signaling. *J Immunol.*169:193-203, 2002.
6. To Y, Dohi M, Matsumoto K, Tanaka R, Sato A, Nakagome K, Nakamura T and Yamamoto K. A two way interaction between hepatocyte growth factor and interleukin-6 on tissue invasion of lung cancer cell line. *Am J Respir Cell Mol Biol.*27:220-226, 2002.
7. Takami K, Takawa N, Okazaki H, Kobayashi M, Ohtoshi T, Kwasaki S, Dohi M, Yamamoto K, Nakamura T, Tanaka M, Nakahara Y and Takizawa H. Interferon-gamma inhibits hepatocyte growth factor-stimulated cell proliferation of human bronchial epithelial cells.Upregulation of p27 (kip1) cyclin-dependent kinase inhibitor. *Am J Respir Cell Mol Biol.*26:231-238, 2002.
8. Misaki Y, Ezaki I, Ariga T, Kawamura N, Sakiyama Y and Yamamoto K. Gene-transferred oligoclonal T cells predominantly persist in peripheral blood from an adenosine deaminase- deficient patient during gene therapy. *Mol Ther.*3:24-27, 2001.
9. Yamaguchi M, Hirai K, Komiya A, Miyamasu M, Fukumoto Y, Teshima R, Ohta K, Morita Y, Galli SJ, Ra C and Yamamoto K. Regulation of mouse mast cell surface FcεRI expression by dexamethasone. *Int Immunol.*13:843-851, 2001.
10. Yoshimura C, Miyamasu M, Nagase H, Iikura M, Yamaguchi M, Kawanamai O, Morita Y, Iwata T, Yamamoto K and Hirai K. Glucocorticoids induce basophil apoptosis. *J Allergy Clin Immunol.*108:201-220, 2001.
11. Yamada R, Tanaka T, Unoki K, Nagai T, Sawada T, Ohnishi Y, Tsunoda T, Yukioka M, Maeda A, Suzuki K, Tateishi H, Ochi T, Nakamura Y and Yamamoto K. Association between a single-nucleotide polymorphism in the promoter of the human interleukin-3 gene and rheumatoid arthritis in Japanese patients, and maximum-likelihood estimation of combinatorial effect that two genetic loci have on susceptibility to the disease. *Am J Hum Genet.*68:674-685, 2001.
12. Kawasaki S, Takizawa H, Yoneyama H, Nakayama T, Fujisawa R, Izumizaki M, Imai T, Yoshie O, Hommma I, Yamamoto K and Matsushima K. Intervention of thymus and activation-regulated chemokine attenuates the development of allergic

- airway inflammation and hyperresponsiveness in mice. *J Immunol.*166:2055-2062, 2001.
13. Setoguchi K, Misaki Y, Terauchi Y, Yamauchi T, Kawahata K, Kadowaki K and Yamamoto K. Peroxisome proliferator-activated receptor- γ haploinsufficiency enhances B cell proliferative responses and exacerbates experimentally induced arthritis. *J Clin Invest.*108:1667-1675, 2001.
 14. To Y, Dohi M, Tanaka R., Sato A, Nakagone K, and Yamamoto K. Early IL-4-dependent response can induce airway hyperreactivity in amouse model of asthma. *Lab Invest.*81:1385-96, 2001.
 15. Kanda H, Kubo K, Hamasaki K, Kanda Y, Nakao A, Kitamura T, Fujita T, Yamamoto K, Mimura T. Influence of various hemodialysis membrane on the plasma (1 \rightarrow 3)- β -D-glucan level. *Kidney Int.*60:319-23, 2001.
 16. Nagase H, Miyamasu M, Yamaguchi M, Fujisawa T, Ohta K, Yamamoto K, Morita Y and Hirai K. Expression of CXCR4 in eosinophils:Functional analyses and cytokine- mediated regulation. *J Immunol.*164:5935-43, 2000.
 17. Sasaki M, Nakamura S, Ohyama Y, Shinohara M, Ezaki I, Hara H, Kadena T, Kishihara K, Yamamoto K, Nomoto K and Shirasuna K. Accumulation of common Tcell clonotypes in the salivary glands of patients with human T lymphotropic virus typeI-associated and idiopathic Sjögren's syndrome. *J Immunol.*164:2823-2831, 2000.
 18. Fujio K, Nosaka T, Kojima T, Kawashima T, Yahata T, Copeland NG., Gilbert DJ, Jenkins NA, Yamamoto K, Nishimura T and Kitamura T. Molecular cloning of a novel type 1 cytokine receptor similar to the common gamma chain. *Blood.*95:2204-2210, 2000.
 19. Sawabe T, Shiokawa S, Sugisaki K, Tsuda T and Yamamoto K. Accumulation of common clonal T cells in multiple lesions of sarcoidosis. *Mol Medicine.*6:793-802, 2000.
 20. Sekiya T, Miyamasu M, Imanishi M, Yamada H, Nakajima T, Yamaguchi M, Fujisawa T, Pawankar R, Sano Y, Ohta K, Ishii A, Morita Y and Yamamoto K. Matsushi K. Yoshie O. and Hirai K. Inducible expression of a Th2-type CC chemokine thymus- and activation-regulated chemokine (TARC) by human bronchial epithelial cells. *J Immunol.*165:2205-2213, 2000.
 21. Nagase H, Yamaguchi M, Jibiki S, Yamada H, Ohta K, Kawasaki H, Yoshie O, Yamamoto K, Morita Y and Hirai K. A rapid and simple photometric assay for quantification of eosinophil chemotaxis. *Int Arch Allergy Immunol.*122:10-14, 2000.
 22. Fujio K, Misaki Y, Setoguchi K, Morita S, Kawahata K, Kato I, Nosaka T, Yamamoto K and Kitamura T. Functional reconstitution of classII MHC-restricted Tcell immunity mediated by retroviral transfer of the a b TCR complex. *J Immunol.*165:528- 532, 2000.
 23. Setoguchi K, Misaki Y, Araki Y, Fujio K, Kawahata K, Kitamura T and Yamamoto K. Antigen-specific T cells transduced with IL-10 ameliorate experimentally induced arthritis without impairing the systemic immune response to the antigen. *J Immunol.* 165:5980-5986, 2000.
 24. Nagase H, Miyamasu M, Yamaguchi T, Kawasaki H, Ohta K, Yamamoto K, Morita Y and Hirai K. Glucocorticoids preferentially upregulate functional CXCR4 expression in eosinophils. *J Allergy Clin Immunol.*106:1132-1139, 2000.
 25. Suzuki T, Kono H, Hirose N, Okada M, Yamamoto T, Yamamoto K and Honda Z. Differential involvement of Src family kinases in Fc gamma receptor-mediated phagocytosis. *J Immunol.*165:473-482, 2000.
 26. Honda Z, Suzuki T, Kono H, Okada M, Yamamoto T, Ra C, Morita Y and Yamamoto K. Sequential requirements of the N-terminal palmitoylation site and SH2 domain of Src family kinases in the initiation and progression of Fcepsilon RI signaling. *Mol Cell Biol.*20:1759-1771, 2000.
 27. Furukawa H, Yabe T, Watanabe K, Miyamoto R, Miki A, Akaza T, Tadokoro K, Tohma S, Inoue T, Yamamoto K and Juji T. Tolerance of NK and LAK activity for HLA class I-deficient targets in a TAP-deficient patient. (bare lymphocyte syndrome type I) *Hum Immunol.*60:32-40, 1999.
 28. Matsui T, Kurokawa M, Kobata T, Oki S, Azuma M, Tohma S, Inoue T, Yamamoto K, Nishioka K and Kato T. Autoantibodies to Tcell co-stimulatory molecules in systemic autoimmune diseases. *J Immunol.*162:4328-4335, 1999.
 29. Furukawa H, Murata S, Yabe T, Shimbara N, Keicho N, Kashiwase K, Watanabe K, Ishikawa Y, Akaza T, Tadokoro K, Tohma S, Inoue T, Tokunaga K, Yamamoto K, Tanaka K and Juji T. Splice acceptor site mutation of transporter associated with antigen processig-1 gene in human bare lymphocyte syndrome. *J Clin Invest.*103:755-758,1999.
 30. Nagahori T, Dohi M, Matsumoto K, Saitoh K, Honda ZI, Nakamura T and Yamamoto K. Interferon-gamma upregulates the c-Met/hepatocyte growth factor receptor expression in alveolar epithelial cells. *Am J Resp Cell Mol Biol.*21:490-497, 1999.
 31. Kawahata K, Misaki Y, Komagata Y, Setoguchi K, Tsunekawa S, Yoshikawa Y, Miyazaki J and Yamamoto K. Altered expression level of a systemic nuclear autoantigen determines the fate of immune response to self. *J Immunol.*162:6482-6491, 1999.
 32. Furukawa H, Yabe T, Akaza T, Tadokoro K, Tohma S, Inoue T, Tokunaga K, Yamamoto K, Geraghty DE and Juji T. Cell surface expression of HLA-E molecules on PBMC from a TAP1-deficient patient. *Tissue Antigens.*53:292-295, 1999.
 33. Takizawa H, Ohtoshi T, Kawasaki S, Kohyama T, Desaki M, Kasama T, Kobayashi K, Nakahara K, Yamamoto K, Matsushima K and Kudoh S. Diesel exhaust particles induce NF- κ B activation in human bronchial epithelial cells in vitro:Importance in cytokine transcription. *J Immunol.*162:4705-4711,1999.
 34. Miyamasu M, Yamaguchi M, Nakajima T, Misaki Y, Morita Y, Matsushima K, Yamamoto K and Hirai K. Th1-derived cytokine IFN- γ is a potent inhibitor of

- eotaxin synthesis in vitro. *Int Immunol.*11:1001-1004, 1999.
35. Iikura M, Yamaguchi M, Miyamasu M, Morita Y, Iwase T, Moro I, Yamamoto K and Hirai K. Secretory IgA-mediated basophil activation. *Biochem Bioph Res Co.*264:575- 579, 1999.
 36. Miyamasu M, Nakajima T, Misaki Y, Izumi S, Tsuno N, Kasahara T, Yamamoto K, Morita Y and Hirai K. Dermal fibroblasts represent a potent major source of human eotaxin:in vitro production and cytokine-mediated regulation. *Cytokine.*11:751-758, 1999.
 37. Murata S, Kawahara H, Tohma S, Yamamoto K, Kasahara M, Nabeshima Y, Tanaka K and Chiba T. Growth retardation in mice lacking the proteasome activator PA28g. *J Biol Chem.*274:38211-38215, 1999.
 38. Kanda H, Mimura T, Hamasaki K, Yamamoto K, Yazaki Y, Hirai H and Nojima Y. Fyn and Lck tyrosine kinase regulate tyrosine phosphorylation of p105CasL, a member of the p130Cas docking protein family, in T-cell receptor-mediated signalling. *Immunol.* 97:56-61, 1999.
 39. Kubo K, Miyagawa K, Yamamoto R, Hamasaki K, Kanda K, Fujita T, Yamamoto K, and Mimura T. Detection of WT1 mRNA in urine from Patients with kidney diseases. *Eur J Clin Invest.*29:824-826, 1999.
 40. Dohi M, Tsukamoto S, Nagahori T, Shinagawa K, Saitoh K, Tanaka Y, Kobayashi S, Tanaka R, To and Yamamoto K. Noninvasive system for evaluating the allergen-specific airway response in a murine model of asthma. *Lab Invest.*79:1559-15, 1999.
 41. Furukawa H, Yabe T, Watanabe K, Miyamoto R, Akaza T, Tadokoro K, Tohma S, Inoue T, Yamamoto K and Juji T. An alternatively spliced form of the human CD94 gene. *Immunogenetics.*48:87-88, 1998.
 42. Nakajima T, Yamada H, Iikura M, Miyamasu M, Izumi S, Shida H, Ohta K, Imai T, Osamu Y, Mochizuki M, Schroder J, Morita Y, Yamamoto K and Hirai K. Intracellular localization and release of eotaxin from normal eosinophils. *FEBS Lett.*434:226-230, 1998.
 43. Miyazawa K, Mori A, Yamamoto K and Okudaira H. Transcriptional roles of C/EBP- β , NF- κ B, and CBF/m interleukin-1 β -induced interleukin-6 synthesis by human rheumatoid fibroblast-line synoviocytes. *J Biol Chem.*273:7620-7627, 1998.
 44. Miyazawa K, Mori A, Yamamoto K and Okudaira H. Constitutive transcription of the human IL-6 gene by rheumatoid synoviocytes spontaneous activation of NF- κ B and CBF1. *Am J Pathol.*152:793-803, 1998.
 45. Shiokawa S, Nishikawa J, Ohshima K, Uike N and Yamamoto K. Establishment of a novel B cell clonality analysis using single-strand conformation polymorphism of immunoglobulin light chain messenger signals. *Am J Pathol.*153:1393-1400, 1998.
 46. Suzuki T, Shoji S, Yamamoto K, Nada S, Okada M, Yamamoto T and Honda Z. Essential roles of Lyn in fibronectin-mediated filamentous actin assembly and cell motility in mast cells. *J Immunol.*161:3694-3701, 1998.
 47. Iikura M, Yamaguchi M, Fujisawa T, Miyamasu M, Takaishi T, Morita Y, Iwase T, Moro I, Yamamoto K and Hirai K. Secretory IgA induces degranulation from IL-3-primed basophils. *J Immunol.*161:1510-1515, 1998.
 48. Uozumi N, Kume K, Nagase T, Nakatani N, Ishii S, Tashiro F, Komagata Y, Maki K, Ikuta K, Ouchi Y, Miyazaki J, and Shimizu T. Role of cytosolic phospholipase A2 in allergic response and parturition. *Nature.*390:618-622, 1997.
 49. Honda Z, Suzuki T, Hirose N, Aihara M, Shimizu T, Nada S, Okada M, Ra C, Morita Y and Ito K. Roles of C-terminal Src kinase in the initiation and the termination of the high affinity IgE receptor-mediated signaling. *J Biol Chem.*272:25753-25760, 1997

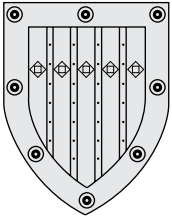

Department of Psychosomatic Medicine

Outline and Research Objectives

Department of Psychosomatic Medicine was founded in 1972 at the Branch Hospital of the University of Tokyo.

Our department started as a clinical section for seeing 'psychosomatic diseases' that are physical diseases whose onset and courses are greatly affected by psychosocial, stress-related factors in the field of internal medicine. However, we have come to cover many patients of eating disorders, panic disorders, and mild depression that are not strictly psychosomatic diseases but share common features of the presence of many physical symptoms and the influence of psychosocial factors.

Based on these historical circumstances, our department has mainly focused on the problems of eating disorders and has also studied panic disorder and mild depression. However, we have also actively studied lifestyle-related and adult diseases such as hypertension (HT), diabetes mellitus (DM), Basedow's disease, and cancers in order to meet the social needs expecting us to see stress-related diseases in the field of internal medicine, investigating what kinds of psychosocial factors are related to their onset and courses and what kinds of psychobehavioral interventions are effective on these diseases. Moreover, we have performed basic and interventional studies of various relaxation procedures that could cancel hazardous effects of stress on our health.

Because psychosomatic medicine on which we rely is rather a new field of medical science born about half a century ago and thus special research methodologies have not been established yet, we should have developed a new method for performing new research. Moreover, the pathological mechanisms of our subjects such as psychosomatic diseases and eating disorders are so complicated by many factors including physical, psychological and behavioral ones, and it has been very difficult for us to empirically uncover their roles one by one.

However, the conditions surrounding our field of research have dramatically changed in recent years, because many new kinds of methods have been developed that can be applied to psychosomatic field including brain functional imaging procedures, ecological momentary assessment (EMA) which means successive monitoring of biopsychobehavioral time series data in daily life, and the discovery and development of basic research of novel eating-related substances. Furthermore, the increase of various psychosocial stress and the acknowledgment of its hazardous effects on health in modern world heighten the social needs for the evidence-based interventional procedures of stress-related diseases far stronger than before. Therefore, our department must greatly contribute to our society in the near future.

Faculties and Students

Professor and Chair	Tomifusa Kuboki, MD, PhD, Since April 1996
Associate Professors	Hiroaki Kumano, MD, PhD
Associate	2
Graduate student	7
Research student.....	1
Secretary	3

Past Research and Major Accomplishments

We have mainly performed clinical research of patients consulting our department and behavioral

scientific research of life-related and adult diseases consulting the department of internal medicine and other physical departments. Furthermore, as a basic research, we have investigated one of the main subjects of psychosomatic medicine that is mind/body correlation meaning interaction between biological, psychological, and behavioral aspects of human being through the study of stress and relaxation. The main fields of our research are as follows and related papers are listed in parentheses the number of which corresponds to the list of Selected Publications.

- 1) Clinical, behavioral scientific, and epidemiological studies on eating disorders (#1,2,3,4,5,10,11,14,16,23,25,30)

- 2) Behavioral scientific, psychophysiological, and interventional studies on lifestyle-related and adult diseases including DM, HT, Basedow's disease, and cancers (#9,13,17,18,21,22,24,26,28,29,31,33,34)
- 3) Studies on other clinical subjects of our department including panic disorder and depression (#6,12,20,27,32,36,37)
- 4) Studies on the development of questionnaires concerning mental health including the TEG, the TSS, the POMS, the LHQ, the SIRI33, and the SSA (#7,28,31,33,35)
- 5) Psychophysiological and interventional studies on various relaxation procedures such as autogenic training, biofeedback, photic feedback, and Qi-gong (#8,15,18,19,26,29,34)

Concerning eating disorders, we did the first country-wide epidemiological study and made the manual of cognitive behavioral therapy and family guidance for carrying out controlled treatment study collaborating on the projects of Ministry of Health and Welfare. Furthermore, we did many clinical studies for clarifying various features of these patients.

Concerning lifestyle-related and adult diseases, we have introduced advanced methodologies of behavioral sciences and data analysis procedures including various multivariate analyses. We have gathered many data on how psychobehavioral problems such as lifestyles, stress, and personality could affect the onset and courses of these diseases. These data are useful for clarifying how we should change what kind of behavior for behavior modification that are regarded to be important for the treatment of these diseases.

Stress and mental health are important research themes of psychosomatic medicine, and we investigated hazardous effects of stress by developing various psychobehavioral questionnaires. We got excellent results such as developing the Tokyo University Egogram (TEG) that are now widely used not only in hospitals but also in companies and schools all over Japan, and the Life Health Questionnaire (LHQ) for assessing multiple stress-related variables based on the data of more than 10,000 healthy people. Furthermore, the questionnaire for examining the risk of certain personality trait on the occurrence of cancers named the Short Interpersonal Reactions Inventory (SIRI33) was also developed, and a collaborative study with the National Cancer Center is now in progress.

Because we speculate that the cumulative effects of stress may precipitate or aggravate psychosomatic diseases, panic disorder, or depression, it is urgently necessary to develop therapeutic procedures soothing the effects of stress. We have investigated various relax-

ation procedures as such stress-reducing methods. As basic research, physical and psychological characteristics of relaxation response have been studied through psychophysiological measures of autonomic nervous system and electroencephalogram (EEG), and a questionnaire assessing psychological relaxation response has been developed. Furthermore, we have done several interventional studies targeting DM, psychosomatic diseases, or depression, and excellent results have been obtained such as very positive effects of Qi-gong group therapy on metabolic control of type 2 DM substantiated by a randomized controlled trial (RCT).

Because psychosomatic medicine is rather a new field of medical science, we should have developed new methods or introduced various methods from adjacent fields for performing new research. As mentioned above, we have achieved several positive results in this point and have made it possible to gather and analyse relevant data, which had never been possible before.

Current Research

We are now advancing more basic research investigating the relationship between physical, psychological and behavioral aspects in the onset and courses of various stress-related diseases using newly developed research methodologies such as noninvasive assessment procedures of brain or autonomic nervous system function and EMA of human time-series bio-information. Furthermore, it should be noted that targets of research have been expanded to include subjects complaining mainly fatigue who suffer from chronic fatigue syndrome (CFS) and multiple chemical sensitivities (MCS) and both healthy and mildly demented geriatric population.

Now we have four active research laboratories in our department, and each is pursuing various research projects as follows making full use of unique methodologies and collaborating with many outside institutes and researchers.

1) Behavioral Science Laboratory

Objectives: In order to clarify the disease processes and ways of treatment of lifestyle-related diseases and psychosomatic diseases, we should deal with the functional aspect of subjects focusing on behavior meaning how they live a daily life as well as the anatomical aspect focusing on body and the introspective aspect focusing on mind. The objectives of this laboratory are to investigate behavior as well as its relation with mind and body of various subjects ranging from psychosomatic patients to healthy persons.

Methodologies: Using questionnaires, personal digital assistants, psychophysiological assessment

procedures, or blood chemistry, the multiple data concerning behavior, mind and body are gathered. Then, the structure within the data is precisely extracted by making full use of many kinds of data analysis methods such as multivariate analyses, time-series analyses, and analysis of variance.

Projects:

DM: Cross-sectional and longitudinal studies to clarify multiple psychosocial factors affecting metabolic control and quality of life (QOL) of diabetic patients

Tension-type headache: An interventional study by autogenic training

Cancer: A semi-prospective study of the role of type C personality on the onset of prostate cancer; A prospective study of personality factors affecting the onset of various cancers in healthy persons

Renal failure: A cross-sectional study on the relationship between stress-related factors and metabolic control and QOL of hemodialysis patients

MCS: A cross-sectional study on stress-related factors affecting their onset and courses

Depression: To determine the diagnostic criteria of mild depression

Elderly people: Cross-sectional and longitudinal studies to clarify the relationship between bodily function, exercise ability, lifestyle, and stress-related factors

2) Bio-signal Analysis Laboratory

Objectives: Although human body produces various kinds of signals, most of them are not captured and discarded as noise. However, as many novel signal analysis methods have been developed these days, we can now extract valuable information from signals previously regarded as noise and can investigate such a field as has been difficult to be targeted by scientific inquiries. The objectives of this laboratory are to understand pathophysiology, mind/body correlation, stress, or relaxation by using such novel methodologies.

Methodologies: Higher brain functions are analyzed by use of positron emission tomography (PET), functional magnetic resonance imaging (fMRI), magnetic encephalography (MEG), and EEG. Autonomic as well as central nervous functions are estimated by spectral and fractal analyses of heart rate variabilities. Ecological changes of heart rate variabilities, bodily movement, mood, symptoms, and toxic substances in the environment are successively monitored by EMA methods.

Projects:

PET: Measurement of cerebral blood flow or glucose metabolism before and after the treatment of anorexia nervosa or panic disorders; Investigation on the relationship between stress coping processes and cerebral blood flow

EEG: Studies assessing the improvement of cerebral cortical function by some relaxation procedures using the dipole tracing method; Assessment of patients with various diseases by event-related potentials (ERP)

Heart rate variabilities & EMA: A study on autonomic nervous activities and bodily movement in the refeeding phase of anorexia nervosa; Development of autonomic nervous function database of outpatients in our department; Comprehensive assessment of multiple chemical sensitivities and chronic fatigue syndrome by EMA methods

3) Neuro-immuno-endocrinology Laboratory

Objectives: The biological basis of mind/body correlation is regarded as 'functional association between neuroendocrine and immune systems', that is sought to be clarified by clinical as well as basic methods in this laboratory. Brain mechanism affecting abnormal eating behavior is also a main focus to be inquired. In addition, the search for physiological measures of stress responses and their application to clinical field is another challenge.

Methodologies: Methods of functional morphology and behavioral analysis are used for analyzing genetically-modified mice such as a knockout mouse. We take notice of 8-hydroxy-2'-deoxy guanosine (8OHdG) as an oxidated substance of DNA and measure it in human urine.

Projects:

Inflammatory cytokines: Analyses of expression and mechanism of action in brain tissue of inflammatory cytokines such as IL-1 and IL-6 as modulators of neuroendocrine and immune systems

Eating modulating substances: Investigation on the effects of newly-found neuropeptides such as orexin and ghrelin in brain on emotion and stress responses

Novel stress measure: Investigation on the usefulness of 8OHdG as a physiological measure in human stress-related diseases

4) Eating Disorders Laboratory

Objectives: The etiology of eating disorders such as anorexia nervosa and bulimia nervosa was assumed to be affected by many factors including individual psychological, biological, familial, socio-cultural factors. The objectives of this laboratory are to study various factors relating to the courses of eating disorders, to develop and improve treatment procedures, and to do the basic research of pathophysiology collaborating with other laboratories.

Methodologies: Bio-psycho-behavioral clinical data at the initial visit and during treatment courses are gathered; Pathophysiology of eating disorders is investigated by PET or EMA.

Projects:

Dropout: A study by survival analysis on premature termination of outpatient treatment

Refeeding: Assessment of energy metabolism, autonomic nervous function, and bodily movement in the refeeding phase of anorexia nervosa patients

Cerebral blood flow and dopaminergic metabolism: Pet studies of anorexia nervosa patients

Future Prospects

We want to continue to advance activities of above-mentioned four laboratories and to focus on the following points in particular.

- 1) Brain processes closely related to mind/body correlation in various stress-related diseases and pathogenic brain functional abnormalities will be clarified by active use of functional brain analysis methods such as PET, fMRI, MEG, ERP, and dipole tracing methods.
- 2) Ecological changes in everyday life of biological, psychological, behavioral, and environmental measures will be monitored and analyzed in order to characterize neurobehavioral basis of various stress-related diseases by developing and utilizing relevant EMA methods.
- 3) Treatment programs will be developed that intervene psychobehavioral factors found to be closely related to the processes of psychosomatic diseases and lifestyle-related diseases by our behavioral scientific studies and include effective relaxation procedures. Then, the evidence will be shown that these interventions are effective in improving not only symptoms but also QOL and life satisfaction by carrying out RCT of these treatment programs.
- 4) Biological and material basis of eating disorders will be pursued by both basic research such as one using genetically-modified mice and clinical research measuring eating-related substances in the blood of eating disorders patients before and after oral glucose tolerance tests.

In summary, we are going to advance toward two directions. First, we will change over from the previous research system mainly relying on clinical and psychobehavioral domains to the new research system that enables us to investigate neurobehavioral and biological mechanisms actively utilizing novel methodologies. Then, we will accumulate useful data for the development of biological treatment by broadening our horizons from mind/body correlation to mind/brain/body correlation and by seeking for the true nature of pathological processes of stress-related diseases.

Secondly, we will make it possible to gather diverse data in patients' everyday life by incorporating

EMA into behavioral scientific methodologies, and then we will aim to clarify the reality of not only diseases themselves but also patients having such diseases. Based on these results as well as our present knowledge, we will develop treatment programs including interventions manipulating psychobehavioral variables and relaxation procedures and will clarify by RCT what kinds of interventions most effectively improve not only symptoms but also QOL and life satisfaction.

Research Grant

- 1) Grant of Ministry of Health, Labor and Welfare Sick House Syndrome(SHS)---Studies of patho-physiology, method of diagnosis and its treatment.
- 2) Grant of Ministry of Health, Labor and Welfare Eating disorder- Studies of neurology and endocrinology.
- 3) Grant of Ministry of Health, Labor and Welfare A guideline for the diagnosis and treatment of psychosomatic diseases 2002
- 4) Grant of Ministry of Health and Welfare Studies of stress management

Select Publications

1. Suematsu H, Ishikawa H, Kuboki T, Ito T. Statistical studies on anorexia nervosa in Japan: detailed clinical data on 1,011 patients. *Psychother Psychosom* 43(2):96-103, 1985.
2. Suematsu H, Kuboki T, Itoh T. Statistical studies on the prognosis of anorexia nervosa. *Psychother Psychosom* 43(2):104-12, 1985.
3. Suematsu H, Kuboki T, Ogata E. Anorexia nervosa in monozygotic twins. *Psychother Psychosom* 45(1):46-50, 1986.
4. Kuboki T, Suematsu H, Ogata E, Yamamoto M, Shizume K. Two cases of anorexia nervosa associated with Graves' disease. *Endocrinol Jpn* 34(1):9-12, 1987.
5. Kumano H, Kuboki T, Tawara R, Sasaki T, Nomura S, Suematsu H, Ogata E. Interrelationship between serum muscle enzymes and a low T3 in anorexia nervosa. *Endocrinol Jpn* 37(4):583-9, 1990.
6. Kuboki T, Ide M, Kumano H, Nomura S, Suematsu H. Historical review of panic disorder and clinical studies in Japan. *Journal of Psychiatric Research* 24(Suppl.1):70-72, 1990.
7. Kuboki T, Nomura S, Wada M, Akabayashi A, Nagataki M, Suematsu H, Yokoyama K, Araki S. Multidimensional assessment of mental state in occupational health care--combined application of three questionnaires: Tokyo University Egogram (TEG), Time Structuring Scale (TSS), and Profile of Mood States (POMS). *Environ Res* 61(2):285-98, 1993.
8. Nakamoto C, Kumano H, Horie H, Nomura S, Kuboki T, Suematsu H, Yasushi M, Saitou S, Chijiwa M. Psychological and physiological effects of photic feedback system. *Shinshin-Igaku* 33(5):371-80, 1993.

9. Horie H, Kumano H, Nomura S, Kuboki T, Suematsu H, Hagura R. Multiple psychosocial factors influencing diabetes mellitus: Multivariate analysis by quantification type I method. *Shinshin-Igaku* 33(8):667-674, 1993.
10. Berger D, Saito S, Ono Y, Tezuka I, Shirahase J, Kuboki T, Suematsu H. Dissociation and child abuse histories in an eating disorder cohort in Japan. *Acta Psychiatr Scand* 90(4):274-80, 1994.
11. Berger D, Ono Y, Saito S, Tezuka I, Takahashi Y, Uno M, Ishikawa Y, Kuboki T, Asai M, Suematsu H. Relationship of parental bonding to child abuse and dissociation in eating disorders in Japan. *Acta Psychiatr Scand* 91(4):278-82, 1995.
12. Kumano H, Kuboki T, Ide M, Okabe F, Suematsu H. Exercise tolerance evaluated by respiratory gas analysis during treadmill exercise test in panic disorder patients. *Jpn J Psychosom Med* 35(8):671-679, 1995.
13. Horie H, Kumano H, Kuboki T, Suematsu H, Hagura R. Multiple psychosocial factors influencing non-insulin-dependent diabetes mellitus (II). *Shinshin-Igaku* 35(6):501-509, 1995.
14. Kuboki T, Nomura S, Ide M, Suematsu H, Araki S. Epidemiological data on anorexia nervosa in Japan. *Psychiatry Res* 16:62(1):11-6, 1996.
15. Kumano H, Horie H, Shidara T, Kuboki T, Suematsu H, Yasushi M. Treatment of a depressive disorder patient with EEG-driven photic stimulation. *Biofeedback Self Regul* 21(4):323-34, 1996.
16. Kumano H, Yamauchi Y, Matsumoto S, Sakano Y, Kuboki T, Suematsu H. Cognitive behavior therapy for eating disorders: Its advantages and shortcomings. *Jpn J Psychosom Med* 37(1):55-60, 1997.
17. Yoshiuchi K, Nomura S, Ando K, Ohtake T, Shimosawa T, Kumano H, Kuboki T, Suematsu H, Fujita T. Hemodynamic and endocrine responsiveness to mental arithmetic task and mirror drawing test in patients with essential hypertension. *Am J Hypertens* 10(3):243-9, 1997.
18. Nakao M, Nomura S, Shimosawa T, Yoshiuchi K, Kumano H, Kuboki T, Suematsu H, Fujita T. Clinical effects of blood pressure biofeedback treatment on hypertension by auto-shaping. *Psychosom Med* 59(3):331-8, 1997.
19. Kumano H, Horie H, Kuboki T, Suematsu H, Sato H, Yasushi M, Kamei T, Masumura S. EEG-driven photic stimulation effect on plasma cortisol and beta-endorphin. *Appl Psychophysiol Biofeedback* 22(3):193-208, 1997.
20. Nakao M, Nomura S, Yamanaka G, Kumano H, Kuboki T. Assessment of patients by DSM-III-R and DSM-IV in a Japanese psychosomatic clinic. *Psychother Psychosom* 67(1):43-9, 1998.
21. Nakao M, Shimosawa T, Nomura S, Kuboki T, Fujita T, Murata K. Mental arithmetic is a useful diagnostic evaluation in white coat hypertension. *Am J Hypertens* 11(1 Pt 1):41-5, 1998.
22. Yoshiuchi K, Kumano H, Nomura S, Yoshimura H, Ito K, Kanaji Y, Ohashi Y, Kuboki T, Suematsu H. Stressful life events and smoking were associated with Graves' disease in women, but not in men. *Psychosom Med* 60(2):182-5, 1998.
23. Nakao M, Kumano H, Nomura S, Kuboki T, Yokoyama K, Murata K. Fatigue mood as an indicator discriminating between anorexia nervosa and bulimia nervosa. *Acta Psychiatr Scand* 97(3):202-5, 1998.
24. Yoshiuchi K, Kumano H, Nomura S, Yoshimura H, Ito K, Kanaji Y, Kuboki T, Suematsu H. Psychosocial factors influencing the short-term outcome of antithyroid drug therapy in Graves' disease. *Psychosom Med* 60(5):592-6, 1998.
25. Nakao M, Kumano H, Nomura S, Kuboki T, Murata K. Assessment of ego state in anorexia nervosa and bulimia nervosa. *Acta Psychiatr Scand* 99(5):385-7, 1999.
26. Nakao M, Nomura S, Shimosawa T, Fujita T, Kuboki T. Blood pressure biofeedback treatment, organ damage and sympathetic activity in mild hypertension. *Psychother Psychosom* 68(6):341-7, 1999.
27. Fukunishi I, Berger D, Wogan J, Kuboki T. Alexithymic traits as predictors of difficulties with adjustment in an outpatient cohort of expatriates in Tokyo. *Psychol Rep* 85(1):67-77, 1999.
28. Kumano H, Orii Y, Suzukamo Y, Yamauchi Y, Munakata M, Yoshinaga K, Seto M, Sakano Y, Agari I, Kuboki T. A trial of developing the Japanese brief version of the Short Interpersonal Reactions Inventory: To measure the Cancer-prone Personality. *Jpn J Psychosom Med* 39(5):55-60, 1999.
29. Nakao M, Nomura S, Shimosawa T, Fujita T, Kuboki T. Blood pressure biofeedback treatment of white-coat hypertension. *J Psychosom Res* 48(2):161-9, 2000.
30. Nakahara R, Yoshiuchi K, Yamanaka G, Sasaki T, Suematsu H, Kuboki T. Coping skills in Japanese women with eating disorders. *Psychol Rep* 87(3 Pt 1):741-6, 2000.
31. Kumano H, Orii Y, Yamauchi Y, Seto M, Agari I, Sakano Y, Munakata M, Yoshinaga K, Sasaki T, Kuboki T. A trial of developing the Japanese brief version of the Short Interpersonal Reactions Inventory (2nd report): Revision to the 33 items version. *Jpn J Psychosom Med* 40(6):447-54, 2000.
32. Nakao M, Yamanaka G, Kuboki T. Major depression and somatic symptoms in a mind/body medicine clinic. *Psychopathology* 34(5):230-5, 2001
33. Kumano H, Kuboki T, Orii Y, Fukuse T, Hirata T, Shinohara K, Seto M, Agari I, Sakano Y. The investigation of the discriminant validity of the measurement of type C personality using the Japanese brief version of the Short Interpersonal Reactions Inventory (SIRI33). *Jpn J Psychosom Med* 41(8):593-99, 2001.
34. Tsujiuchi T, Kumano H, Yoshiuchi K, He D, Tsujiuchi Y, Kuboki T, Suematsu H, Hirao K. The effect of Qi-gong relaxation exercise on the control of type 2 diabetes mellitus: a randomized controlled trial. *Diabetes Care* 25(1):241-2, 2002.

35. Nakao M, Barsky AJ, Kumano H, Kuboki T. Relationship between somatosensory amplification and alexithymia in a Japanese psychosomatic clinic. *Psychosomatics* 43(1):55-60, 2002.
36. Nakao M, Yamanaka G, Kuboki T. Suicidal ideation and somatic symptoms of patients with mind/body distress in a Japanese psychosomatic clinic. *Suicide Life Threat Behav* 32(1):80-90, 2002.
37. Nakao M, Ando K, Nomura S, Kuboki T, Uehara Y, Toyooka T, Fujita T. Depressive mood accompanies hypercholesterolemia in young Japanese adults. *Jpn Heart J* 42(6):739-48, 2001.

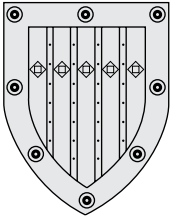

Department of Clinical Laboratory Medicine

Outline and Research Objectives

Department of Clinical Laboratory Medicine, Tokyo University Graduate School of Medicine, was established in 1997 following foundation of Department of Laboratory Medicine, Faculty of Medicine, University of Tokyo in 1984. We have also Clinical Laboratory Center which was established in 1952 in Tokyo University Hospital. The Department cooperates with Clinical Laboratory Center not only in giving lectures and clinical education to medical students but also in carrying out researches. The Department of Clinical Laboratory Medicine is composed of only two staffs, a professor and an associate professor, but Clinical Laboratory Center possesses four positions of lecturers and two of associates. The professor and the associate professor of the Department are the director and the vice-director of Clinical Laboratory Center, respectively.

In our department five or six research projects have been usually undertaken.

Faculties and Students

Professor and Chair Kazuhiko Nakahara, M.D. (1997~)
Associate Professor Kiyoshi Kitamura, M.D.(1998~2002)
Graduate Student.....1
Secretary1

Past Research and Major Accomplishments

1. Cell surface analysis using flow cytometry

The major purpose of this project was to apply the immunological methods to actual clinical fields, for instance to diagnosis hematological malignancies such as leukemia and lymphoma. We found that a kind of glycolipids, asialo GM1, is the candidate of cell surface markers for diagnosis of acute lymphoblastic leukemia by using the method of flow cytometry. For the next steps in this project, we discovered flow cytometric analysis using several monoclonal antibodies reacted against human blood cells, especially lymphocytes, is very useful tool to diagnose human hematological disorders. To give an example, we mentioned that adult T-cell leukemia cells are CD4 positive but negative for CD8, and very clear pattern of the positive sharp peak could be shown on the display of flow cytometry. We also demonstrated that not only single-color but also multi-color analysis with monoclonal antibodies and flow cytometry is very important to investigate some kinds of illness in more detail.

For the purpose of evaluating lymphocyte activation, we have studied lymphocyte surface antigens, plasma soluble CD4 or CD8, and intracellular pH (pHi) of lymphocytes, especially in infectious mononucleo-

sis (IM) in which proliferation of T lymphocytes is supposed to play an important role in regulation of EB virus. Immunofluorescence analysis demonstrates increase or decrease of lymphocyte subset as well as expression of activation antigens. During IM, CD8⁺ T cells are quantitatively the major population of expanded lymphocytes and they coexpress HLA-DR and CD45RO. Elevated serum levels of soluble CD8 (sCD8) and soluble CD4 (sCD4) are regarded as markers of T cell activation. We demonstrated marked increase in sCD8 and significant increase in sCD4 which strongly suggest activation of both CD8⁺ and CD4⁺. The elevation of plasma sCD8 is due to expansion of CD8⁺ subset as well as increased sCD8 release from each CD8⁺ cell.

Additionally we tried to apply the flow-cytometric analysis method to measure intracellular pH (pHi), which shows one of the indices of cellular activation. For the purpose of evaluating intracellular pH of each lymphocyte subset, simultaneous measurement of pHi and cell surface antigen was developed using 2'-7'-bis(carboxyethyl)5,6-carboxyfluorescein (BCECF) and flow-cytometry. A significant increase in pHi of CD8⁺ lymphocytes from patients with IM and its correlation with number of CD8⁺-HLA-DR⁺ lymphocytes as well as plasma levels of soluble CD8 strongly suggest activation of CD8⁺ lymphocytes.

2. Effects of age, body-mass index and life-style habits on clinical laboratory data.

2-1 Alcohol drinking and clinical laboratory data

Epidemiological studies have consistently shown that light or light/moderate drinkers are at a lower risk of coronary heart disease (CHD). The mecha-

nisms of this association include beneficial effects on HDL- and LDL-cholesterol, insulin sensitivity, platelet aggregation, blood coagulation and fibrinolysis. However, drinking also has disadvantageous effects on blood pressure, triglycerides and uric acid.

The purpose of our study was 1) to clarify whether there are individual varieties regarding the response of clinical laboratory data to alcohol consumption, and 2) what are the factors responsible for the individual varieties.

2-1-1 Are there individual varieties regarding the response of clinical laboratory data to alcohol consumption?

We performed a cross-sectional study of 3130 Japanese male workers with a body-mass index below 24. The subjects were divided into 2 groups; a normal γ -glutamyl transpeptidase (rGTP) (<40 IU/L) group and a high rGTP (>40 IU/L) group, and the values were compared after adjusted for age, body-mass index, exercise and smoking. The level of triglycerides increased according to the amount of drinking in the high rGTP group, whereas no association was observed in the normal rGTP group. The level of HDL-cholesterol increased with drinking in the normal and high rGTP groups, and no difference was observed in the levels of HDL-cholesterol between the two groups. The levels of uric acid and blood pressure also increased with drinking in both groups, but the increase was bigger in the high rGTP group than in the normal rGTP group. The results indicated that there was large individual variability in the responses of the risk factors for coronary heart disease to drinking. Subjects whose rGTP responds less to drinking may have less disadvantageous effects of drinking.

2-1-2 Is there any good way of drinking for health?

We performed a cross-sectional study of 3660 male workers to examine whether the weekly frequency of drinking affects clinical laboratory data when the weekly amount of drinking is the same. The results suggested that the weekly frequency of drinking might affect the levels of HDL-cholesterol independently of the weekly alcohol consumption.

2-1-3 Are there the genetic factors responsible for individual varieties regarding the response of clinical laboratory data to alcohol consumption?

We examined 133 male workers who drank > 300g of alcohol per week to study the relationship between clinical laboratory data and the genetic polymorphisms of alcohol dehydrogenase (ADH) 2 and aldehyde dehydrogenase (ALDH) 2. The results suggested that the ADH2 genotype influences the responses of blood pressure, triglycerides, and uric acid to alcohol consumption, while the ALDH2 geno-

type influences the response of the erythrocyte mean cell volume to alcohol consumption.

2-2 Others (HbA1C, proteinuria, leptin)

2-2-1 HbA1C

HbA1C has been suggested to deteriorate with age. However, controversy exists as to whether this deterioration is a consequence of the aging process itself or of variables related to aging, such as concomitant disease, medication, body-mass index, physical activity, and the change in distribution of body fat. We performed a cross-sectional survey of 7664 male Japanese workers aged 20-59 years. This survey suggested that HbA1C increased with age itself, and body-mass index and a hereditary predisposition to diabetes affected this age-dependent increase in HbA1C.

2-2-2 proteinuria

We performed a cross-sectional survey of 5174 male Japanese workers. Blood pressure and a family history of diabetes were independent factors associated with proteinuria in subjects with a HbA1C below 5.9% who were not under medication for diabetes. In contrast, HbA1C, obesity and smoking were associated with proteinuria in subjects who were under medication for diabetes and/or have a HbA1C above 5.9%. These findings suggest that maintaining a HbA1C level below 5.9%, non-smoking and a standard body weight may reduce the prevalence of proteinuria in Japanese men. Healthy life-style habits and standard body weight are especially important for subjects with a family history of diabetes.

We also performed a cross-sectional study of 237 men to examine the relationship between proteinuria determined with a reagent strip and the angiotensin converting enzyme (ACE) genotypes. The results suggest that the ACE DD genotype may be an independent risk factor of proteinuria in Japanese men.

2-2-3 leptin

Leptin, the ob gene product secreted by adipocyte, decreases food intake while it increases energy expenditure and functions as an important signal for the regulation of body weight in mouse. To investigate whether smoking affects the serum level of leptin, we performed a cross-sectional study of 708 male workers. The findings suggested that among life-style habits, physical activity, but not smoking or alcohol consumption, significantly affects the serum level of leptin in Japanese men.

The leptin receptor is an isoform of the B219 gene product, a member of the hematopoietin receptor family, which is expressed in very primitive hematopoietic cells. Recent studies showed that leptin plus erythropoietin acted synergistically to increase

erythroid development in vitro. These findings led us to examine the relationship between the serum levels of leptin and hemoglobin. The results of the above cross-sectional study showed that the serum levels of leptin is negatively associated with those of hemoglobin. Although the effect of leptin on hematopoiesis may be modest, the results of our epidemiologic study, together with the previous studies performed in vitro, suggest that leptin may play some role in hematopoiesis in humans.

3. Learning from patients at the points of biochemistry

3-1 Study of apolipoprotein A-I deficiency

We evaluated a 69-year-old Japanese woman with apolipoprotein (apo) A-I deficiency, high levels of LDL-cholesterol, hypertension and impaired glucose tolerance. The patient had corneal opacity, but neither xanthomas, xanthelasma, nor tonsillar hypertrophy. She was not symptomatic for coronary heart disease, and had normal electrocardiograms at rest and during exercise on a cycle ergometer. She had severely reduced levels of HDL-cholesterol (0.10-0.18 mmol/L) and no apo A-I (<0.6 mg/dL). LDL-cholesterol and apo B as well as apo E were increased even under treatment with 10 mg pravastatin per day. Gel filtration chromatography revealed that in addition to VLDL and LDL fractions, she had apo A-II rich and apo E rich fractions, which were present in the HDL fraction separated by ultracentrifugation. A cytosine deletion was identified by genomic DNA sequencing of the apo A-I gene of the patient at the third base of codon 184 in the fourth exon, which led to a frame shift mutation and early termination at codon 200. This patient is the oldest among those with apo A-I deficiency reported in the literature, and she had no symptoms of coronary heart disease despite the accumulated risk for the disease.

3-2 Study of phytosterolemia

We diagnosed two women with multiple xanthomas, intermittent arthritis and thrombocytopenia as phytosterolemia, an autosomal-recessive lipid storage disease, based on their increased serum concentrations of β -sitosterol, campesterol and sitostanol. The gene responsible for this disease is located within a distance of 18 cM between microsatellite markers of D2S1788 and D2S1352 at chromosome 2p21. We genotyped the patients and their family members with 16 microsatellite markers around this locus. The results from the homozygosity mapping of one family suggested that the gene was located within the distance of 12.6 cM between D2S2328 and D2S1352. We have shortened the genetic distance by 5.4 cM.

3-3 Another good effect of pioglitazone, an insulin sensitizing drug

The findings obtained from two patients with diabetes and asthma suggested that pioglitazone may ameliorate symptoms of asthma. Pioglitazone is one of the thiazolidinedione compounds which have been used as antidiabetic drugs. Recent studies have revealed that thiazolidinedione compounds also have various nonhypoglycemic effects, such as antiinflammatory, antiatherosclerotic and anticancer effects, in cultured cells and in experimental animal models. Elucidation of the mechanism may enable the design of a novel class of drugs for asthma.

4. Researches in physiological fields

4-1 Cardiac functions using ultrasound

Major research interests are evaluation of left ventricular and left atrial functions, detection of tissue ischemia using contrast echo, and assessment of cardiac state during inactivity.

4-2 Influence of diesel exhaust particles on respiratory functions

We reported that diesel exhaust particles (DEP) induced nuclear factor-kappa B (NF- κ B) activation, upregulated expression of intercellular adhesion molecule (ICAM)-1 in human bronchial epithelial cells, and benzene-extracted components are important for the major activity of DEP. Increased expression of transforming growth factor- β 1 in small airway epithelium was also demonstrated.

4-3 Investigations on brain functions using magnetoencephalography (MEG)

We installed the MEG system, which is a newly developed tool for neurophysiology, and studied somatosensory evoked magnetic fields to on- and off-sets of rectangular pressure stimuli.

Current Research

1. Quantification of cell surface antigens using flow cytometry

Conventional methods of flow cytometry provide us only a positive percentage of cells. If we can measure and obtain cell surface antigen density, more detail analysis must be possible. The purpose of this project is quantification of cell surface antigens with flow cytometry.

2. Analysis of Th1/Th2, Tc1/Tc2 lymphocytes using flow cytometry

A method to analyze blood samples with EDTA-2K

was developed. Infectious diseases and immunocompromised patients are under investigation.

3. Relationship between genetic polymorphisms of alcohol metabolizing enzymes, and diabetic control and the risk factors for CHD in patients with diabetes.

Subjects: Non-drinkers and drinkers with diabetes

Methods: Genetic polymorphisms of ADH2 and ALDH2 are examined by the PCR.

Objective:

- 1) Is the effect of alcohol drinking on diabetic control associated with the genetic polymorphisms of ADH2 and ALDH2?
- 2) Is the effect of alcohol drinking on the risk factors for CHD associated with the genetic polymorphisms of ADH2 and ALDH2?
- 3) Are those effects observed only in drinkers and not in non-drinkers?

4. Identification of the gene mutation responsible for phytosterolemia in our three patients.

Recent studies showed that phytosterolemia might be explained by mutations of the genes that encode new members of the ATP-binding cassette (ABC) transporter family, ABCG5 and ABCG8. Now we are examining whether our patients have the gene mutations of ABCG5 and ABCG8.

5. Physiological roles of FGF-23

A new comer to our Department has cloned and identified FGF-23 as a causative factors for tumor-induced hypophosphatemic rickets/osteomalacia. We have also established an ELISA assay for biologically active full-length FGF-23. We are now investigating physiological roles of FGF-23 in phosphate and vitamin D metabolism.

6. Adrenomedullin

As another new comer participated in our Department, this new project is started. He has been studying the physiological role of vasoactive peptide to regulate blood pressure by modulating sympathetic tone and its possible role in preventing organ damage. Adrenomedullin, a vasoactive peptide was discovered from pheochromocytoma cells and it is known to exist not only adrenal cells but also vascular smooth muscle cells, endothelial cells, and other organs. He and his colleagues have generated adrenomedullin knockout mice and showed that adrenomedullin prevents organ damage by reducing oxidative stress. In clinical study, they have shown adrenomedullin is better indicator of circulating blood volume than ANP in patients under hemodialysis. The measurement of blood adrenomedullin level will be clinically important marker. On the other hand, to diagnose organ

damage, especially renal damage, we are now investigating new marker in urine from various patients.

7. Analysis of perfusion and function of the left ventricle

Myocardial perfusion is assessed by myocardial contrast echo while regional left ventricular function is evaluated by strain data derived from myocardial Doppler velocity information.

8. Relationship between respiratory function and various pathophysiological condition

The influence of sleep apnea syndrome, lung cancer, asthma, aging or respiratory rehabilitation on pulmonary function has been investigated by a member of our Department.

9. Study using magnetoencephalography (MEG)

We have not only been making efforts to obtain reimbursement for clinical MEG studies but also been organizing several research groups which consists of medical doctors from the department of neurology, physiology, neurosurgery, pediatrics and otolaryngology in the University Hospital and researchers from University of Tokyo School of Medicine. Current themes are follows.

- 1) Epilepsy evaluation-spike source localization
- 2) Pre-surgical functional mapping-somatosensory, motor, auditory, visual and language
- 3) Auditory evoked magnetic response as a measure of sensory gating in schizophrenia
- 4) Abnormality of mismatch negativity in schizophrenic patients
Promote

Future Prospects

We have a future planning in each research theme as follows.

- 1) Apply the quantity analysis method of cell surface antigens with flow cytometry to actual clinical samples and evaluate its usefulness.
- 2) Monitor immunological status of immunocompromised patients and patients with infectious diseases by using lymphocyte activation markers.
- 3) Prospective study on the relation between the mortality due to CHD and alcohol drinking, which takes genetic polymorphisms of alcohol metabolizing enzymes into consideration
- 4) Elucidation of the structures and functions of ABCG5 and ABCG8 and design of a novel class of drugs for hypercholesterolemia
- 5) Study on physiological and pathophysiological roles of FGF-23

- 6) Find new markers to diagnose early phase of renal damage in diabetes or hypertensive patients as well as to diagnose response to treatment.
- 7) Three dimensional analysis of left ventricular perfusion and function using cardiac ultrasonography
- 8) Promote EEG and MEG studies of higher cognitive brain function, especially focused on the investigation of gamma-band activities which are thought to play a key roll in perception and cognition.

It might be said that the research themes of our department are diverse and contain a wide range of subjects. Although we have actually a lot of research projects simultaneously, we can say that it is the characteristic of our department and our common theme is laboratory examination and the key word is laboratory medicine. The purpose of our research is to apply our research products to actual clinical fields, and contribute to human health and welfare. But today's problem in our department is the shortage of the number of graduate students. We must make an effort to obtain them.

Research Grants

1. Grant-in-Aid for Scientific Research (B) from The Ministry of Education, Science, Sports and Culture (1998~2000) : The new application of flow cytometry – Quantification of cell surface antigens and its clinical application –
2. Grant-in-Aid for Scientific Research (B) from The Ministry of Education, Science, Sports and Culture (2001~2003) : Practical utilization of selective cell information using flow cytometry and its clinical application
3. Grant-in-Aid for Scientific Research (C) from The Ministry of Education, Science, Sports and Culture(1999/2000) : Studies on phytosterolemia: Identification of the pathologic gene and examination of its pathogenesis
4. Grant-in-Aid for Scientific Research (C) from The Ministry of Education, Science, Sports and Culture (2001/2002) : Reverse cholesterol transport in apolipoprotein A1 deficiency
5. Grants-in-aid for Promotion of AIDS Research from the Ministry of Health and Welfare of Japan (2000~2002)

Select Publications

1. Nakahara, K., Ohashi, T., Oda, T., Hirano, T., Kasai, M., Okumura, K. & Tada, T. : Asialo GM 1 as a cell-surface marker detected in acute lymphoblastic leukemia. *New England J Medicine*. 302 : 674-677, 1980.
2. Nakahara, K., Ohashi, T., Ichimaru M., Amagasaki, T., Shimoyama, M., Nakauchi & Kumura, K. : Analyses of adult T-cell leukemia using the mono-

- clonal (anti-Leu-1, anti-Leu-2a and anti-Leu-3a) and heterologous anti-glycolipid (anti-asialo GML) antibodies. *Clinical Immunology and Immunopathology*, 25 : 43-52, 1982.
3. Yoneyama, A., Nakahara, K., Higashihara, M. & Kurokawa : Increased levels of soluble CD8 and CD4 inpatients with infectious mononucleosis. *Brit J Haematol* 89 : 47-54, 1995.
4. Aoki, K., Suzuki, K., Sugano, A., Tasaka, T., Nakahara, K., Kuge, O. Omori, A. & Kasai, M. : A novel gene, *Translin*, encodes a recombination hotspott binding protein associated with chromosomal translation. *Nature Genetics* 10: 167-174, 1995.
5. Aoki, I., Homori, M., Nakahara, K., Higashi, K. & Ishikawa : Effects of recombinant human interleukin-1 (rhIL-), -1 (rhIL-1) and rhIL-1 receptor antagonist (rhIL1ra) on erythroid progenitors(CFU-E and BFU-E) in human bone marrow. *Exp Hematology* 23(3):217-25, 1995.
6. Mashige, F., Matsushima, Y., Miyata, C., Yamada, R., Kanazawa, H. Sakuma, I., Takai, N., Shinozuka, N., Ohkubo, A and Nakahara, K. : Simultaneous determination of catecholamines, their basic metabolites and serotonin in urine by high-performance liquid chromatography using a mixed-mode column and an eight-channel electrochemical detector. *Biomedical Chromatography*. 9 : 221-225, 1995.
7. Watanabe, T., Matsushima, S., Okazaki, M., Nagamatsu, S., Hirokawa, K., Uchimura, H. and Nakahara, K. : Localization and ontogeny of GLUT3 expression in the rat retina. *Developmental Brain Research*. 94, 60-66, 1996.
8. Watanabe, T., J. T. Voyvodic., T. Chan-Ling., Sagara, H., Hirokawa, K., Mio, Y., Matsushima, S., Uchimura, H., Nakahara, K. and Martin Raff: Differentiation and morphogenesis in pellet culture of developing rat retinal cells. *The Journal of Comparative Neurology*. 377: 341-350, 1997.
9. Hashimoto Y, Togo M, Sato H, Hashimoto N, Watanabe T, Kurokawa K, and Nakahara K. Characteristics of protein kinase C-independent exocytosis in human platelets. *Thromb Res* 88: 51-58, 1997
10. Aoki, K. Inazawa, J., Takahashi, T., Nakahara, K., and Kasai, M. : Genomic structure and chromosomal localization of the gene encoding *translin*, a recombination hotspot binding protein. *Genomics*, 43 (2) : 237-241, 1997.
11. Hashimoto, Y., Togo, M., Sato, H., Hashimoto, N., Watanabe, T., Kurokawa, K. and Nakahara, K. : Characteristics of protein kinase C-dependent exocytosis in human platelets. *Thrombosis Research*, 88 (1) : 51-58, 1997.
12. Sakurai, S., Shiojima, I., Tanigawa, T., and Nakahara, K. : Aminoglycosides prevent and dissociate the aggregation of platelets in patients with EDTA-dependent pseudothrombocytopenia. *British J. of Haematology*, 99: 817-823, 1997.
13. Koike, Y., Yoneyama, A., Shirai, J., Ishida, T., Shoda, E., Miyazaki, K., Sunaga, S., Horie, R., Aoki, K.,

- Koike, K., Ogata, I., Takahara, T., Kato, T., Nakahara, K., Kariya, T., and Higashihara, M. : Evaluation of thrombopoiesis in thrombocytopenic disorders by simultaneous measurement of reticulated platelets of whole blood and serum thrombopoietin concentrations. *Thromb Haemost.* 79:1106-1110,1998.
14. Kawasaki, S., Takizawa, H., Ohtoshi, T., Takeuchi, N., Kohyama, T., Nakamura, H., Asama, T., Kobayashi, K., Nakahara, K., Morita, Y. And Yamamoto, K. : Roxithromycin inhibits cytokine production by and neutrophil attachment to human bronchial epithelial cells in vitro. *American Agents and Chemotherapy.* 42 (6) 1499-1502, 1998.
 15. Yan, K., Nakahara, K., Awa, S., Nishibori, Y., Nakajima, N., Kataoka, S. Maeda, M., Watanabe, T., Matsushima, S., and Watanabe, N. : The increase of memory T cell subsets in children with idiopathic nephrotic syndrome. *Nephron.*79, 274-278, 1998.
 16. Aoki, K., Meng, G., Suzuki, K., Takashi, T., Kameoka, Y., Nakahara, K., Ishida, R., Kasai, M. : RP58 associates with condensed chromatin and mediates a sequence-specific transcriptional repression. *The Journal of Biological Chemistry.* 273 (41), Issue of October 9, 26698-26704, 1998.
 17. Hashimoto, Y., Hutamura, A., Watanabe, N., Togo, M., Sato, H., Hara, M., Tsukamoto, K., Kimura, S., and Nakahara, K. : Relationship between glycosylated hemoglobin and the prevalence of proteinuria in Japanese men. *Internal Medicine,* 38 (1), 6-11,1999.
 18. Hashimoto, Y., Futamura, A., Watanabe, N., Togo, M., Sato, H., Hara, M., Tsukamoto, K., Kimura, S., and Nakahara, K. : Relationship between glycosylated hemoglobin and the prevalence of proteinuria in Japanese men. *Intern Med.,* 38(1):6-11, 1999.
 19. Togo, M., Tsukamoto, K., Satoh, H., Hara, M., Futamura, A., Nakarai, H., Nakahara, K., Hashimoto, Y. : Relationship Between Levels of Leptin and Hemoglobin in Japanese Men. *Blood.,* 93:4444-4445, 1999.
 20. Okubo, S., Mashige, F., Hashimoto, Y., Nakahara, K., Kanazawa, H., Matsushima, Y., Fukushima, T., Huang, Y., and Imai, I. : D-Serine concentration in blood serum of liver transplanted patient. *Chromatography,* 21:43-47,2000.
 21. Takizawa, H., Abe, S., Ohtoshi, T., Kawasaki, S., Takami, K., Desaki, M., Sugawara, I., Hashimoto, S., Azuma, A., Nakahara, K. and Kudoh, S. : Diesel exhaust particles up-regulate expression of intercellular adhesion molecule-1 (ICAM-1) in human epithelial cells. *Clin Exp Immunol* 120: 356-362, 2000.
 22. Meng, G., Inazawa, J., Ishida, R., Tokura, K., Nakahara, K., Aoki, K. & Kasai, M. : Structural analysis of the gene encoding RP58, a sequence-specific transrepressor associated with heterochromatin. *Gene* 242, 59-64, 2000.
 23. Meng, G., Aoki, K., Tokura, K., Nakahara, K., Inazawa, J. & Kasai, M. : Genomic structure and chromosomal location of the gene encoding TRAX, a Translin-associated factor X. *J Hum Genet* 45: 305-308, 2000.
 24. Okubo, S., Mashige, F., Omori, M., Hashimoto, Y., Nakahara, K., Kanazawa, H. & Matsushima, Y. : Enantiomeric determination of L- and D-lactic acid in human cerebrospinal fluid by chiral ligand exchange high-performance liquid chromatography. *Biomed Chromatogr* 14: 474-477, 2000.
 25. Watanabe, T. and Nakahara, K. : Quantification of cell surface molecule density by flow cytometry. *Symposium Abstract, The Sixth Asian Conference of Clinical Pathology.* S89, 2000.
 26. Yumoto, M., Saitoh, O., Kaneko, Y., Anami, K., Matsuda, H., Ugawa, Y. and Nakahara, K. : Somatosensory evoked magnetic fields to on- and off-sets of rectangular pressure stimuli. *Proc. of 12th International Conference on Biomagnetism,* 243-246, 2000.
 27. Togo, M., Hashimoto, Y., Futamura, A., Tsukamoto, K., Satoh, H., Watanabe, T., Nakarai, H., Nakahara, K., and Kimura, S. : Relationship between serum level of leptin and life-style habits in Japanese men. *Horm Res* 54,169-173,2000.
 28. Togo, M., Toda, T., L.A.Nguyen, Kubota, S., Tsukamoto, K., Satoh, H., Hara, M., Iso-o, N., Noto, H., Kimura, S., Nakahara, K., Seyama, Y. and Hashimoto, Y. : Genetic analysis of phytosterolaemia. *J. Inherit. Metab. Dis.* 24, 43-50, 2001.
 29. Sakurai, S., Takenaka, K., Shiojima, I., Watanabe, F., Sonoda, M., Uno, K., Kuwada, Y., Nakahara, K., and Nagai, R. : Traumatic Tricuspid Insufficiency. *Echocardiography: A J. of CV Ultrasound & Allied Tech.* 18 (4) 303-304, 2001.
 30. Kawasaki, S., Takizawa, H., Takami, K., Desaki, M., Okazaki, H., Kasama, T., Kobayashi, K., Yamamoto, K., Nakahara, K., Tanaka, M., Sagai, M., and Ohtoshi, T. : Benzene-extracted components are important for the major activity of diesel exhaust particles (DEP): Effect on IL-8 gene expression in human bronchial epithelial cells. *Am J Respir Cell Mol Biol* 24, 419-426, 2001.
 31. Hashimoto, Y., Futamura, A., Nakarai, H., Yokota, H., Omura, M., Tsukamoto, K., Togo, M., Sato, H., Hara, M., Isoo, N., Taguchi, J., and Nakahara, K. : Association between deletion polymorphism of angiotensin converting enzyme gene and proteinuria in Japanese overweight men., *J Occup Health.* 43,80-84, 2001.
 32. Sakurai, S., Takenaka, K., Nakahara, K., and Nagai, R. : Traumatic tricuspid insufficiency. *Echocardiography* 18 : 303, 2001.
 33. Takizawa, H., Tanaka, M., Takami, K., Ohtoshi, T., Ito, K., Satoh, M., Okada, Y., Yamasawa, F., Umeda, A., and Nakahara, K. : Increased Expression of Transforming Growth Factor- β 1 in Small Airway Epithelium from Tobacco Smokers and Patients with Chronic Obstructive Pulmonary Disease (COPD). *Am J Respir Crit Care Med* 163, 1476-1483, 2001.
 34. Mashige, F., Tsuno, H. N., Maekawa, M., Okada, S., Tanaka, N., Matsui, S., Watanabe, S. and Nakahara, K. : Noninvasive combination assay of free L-fucose and sulfated bile acids in urine for diagnosis of liver

- and pancreatic diseases and solid tumor. *Journal of Analytical Bio-Science* 24(4) 317-323, 2001.
35. Hashimoto, Y., Futamura, A., Nakarai, H., and Nakahara, K. : Relationship between response of -glutamyl transpeptidase to alcohol drinking and risk factors for coronary heart disease. *Atherosclerosis* 158 465-470, 2001.
 36. Sakurai, S., Takenaka, K., Shiojima I., Watanabe, F., Onoda, M., Uno, K., Kuwada, Y., Nakahara, K., and Nagai, R. : Traumatic Tricuspid Insufficiency. *Echocardiography: A J. of CV Ultrasound & Allied Tech.* 18 (4) 303-304, 2001.
 37. Kawasaki, S., Takizawa, H., Takami, K., Desaki, M., Okazaki, H., Kasama, T., Kobayashi, K., Yamamoto, K., Nakahara, K., Tanaka, M., Sagai, M., and Ohtoshi, T. : Benzene-extracted components are important for the major activity of diesel exhaust particles : Effect on interleukin-8 gene expression in human bronchial epithelial cells. *Am J Respir Cell Mol Biol.* 24, 419-426, 2001.
 38. Hashimoto, Y., Futamura, A., Nakarai, H., and Nakahara, K. : Effects of the frequency of alcohol intake on risk factors for coronary heart disease. *European Journal of Epidemiology* 17, 307-312, 2001.
 39. Sakatani, T., Shimazaki, C., Hirai, H., Okano, A., Hatsuse, M., Okamoto, A., Takahashi, R., Ashihara, E., Inaba, T., Yokota, H., Nakahara, K., Hirai, H. and Nakagawa, M. : Early relapse after high-dose chemotherapy rescued by tumor-free autologous peripheral blood stem cells in acute lymphoblastic leukemia : Importance of monitoring for WT1-mRNA quantitatively. *Leukemia and Lymphoma* 42(1-2), 225-229, 2001.
 40. Yokota, H., Tsuno, N. H., Tanaka, Y., Fukui, T., Kitamura, K., Hirai, H., Osumi, K., Itou, N., H. Satoh, M. Okabe, S, Nakahara, K. : Quantification of Minimal Residual Disease in Patients with *ela2* BCR-ABL Positive Acute Lymphoblastic Leukemia Using a Real-Time RT-PCR Assay. *Leukemia*(16), 1167-1175, 2002.
 41. Yokota H, Hashimoto Y, Okubo S, Yumoto M, Mashige F, Kawamura M, Kotani K, Usuki Y, Shimada S, Kitamura K, Nakahara, K. Apolipoprotein A-I deficiency with accumulated risk for CHD but no symptoms of CHD. *Atherosclerosis* 162: 399-407, 2002
 42. Hashimoto, Y., and Nakahara, K. : Improve of asthma after administration of pioglitazone. *Diabetes Care*, 25(2),401, 2002.
 43. Kanazawa, H., Okada, A., Matsushima, Y., Yokota, H., Okubo, S., Mashige, F., and Nakahara, K. : Determination of omeprazole and its metabolites in human plasma by liquid chromatography-mass spectrometry. *Journal of Chromatography A*, 949, 1-9, 2002.
 44. Ono, Y., Mashige, F., Sano, S., Nanba, Y., Okubo, S., Hashimoto, Y., and Nakahara, K. : α 1-Antichymotrypsin in serum and cerebrospinal fluid Part1 : Development of latex agglutination test for determination of α 1-antichymotrypsin. *Journal of Analytical Bio-Science*, 25(2), 153-158, 2002.
 45. Mashige, F., Ono, Y., Nanba, Y., Okubo, S., Hashimoto Y., and Nakahara, K. : α 1-Antichymotrypsin in serum and cerebrospinal fluid Part2 : Clinical implications of α 1-antichymotrypsin and other acute phase reactant proteins in Alzheimer-type dementia and other diseases. *Journal of Analytical Bio-Science*, 25(2), 159-163, 2002.
 46. Kitamura, K., Miwa, S., Ikemoto, T., Tatsumi, N., Nakahara, K., Higashi, K., and Watanabe, K. : Proposal of guidelines for surface antigen analysis of peripheral lymphocytes using flow cytometry and preliminary quality control. *Global Standardization and Advanced quality Management'01*, Eibun Press, Ltd., Osaka, Japan, pp48, 2002.
 47. Hashimoto, Y., Nakayama, T., Futamura, A., Omura M., and Nakahara, K. : Erythrocytes mean cell volume and genetic polymorphism of aldehyde dehydrogenase 2 in alcohol drinkers. *Blood* 99(9):3487-8, 2002.
 48. Hashimoto, Y., Nakayama, T., Futamura, A., Omura, M., Nakarai, H., and Nakahara, K. : Relationship between genetic polymorphisms of alcohol-metabolizing enzymes and changes in risk factors for coronary heart disease associated with alcohol consumption. *Clinical Chemistry*, 48(7), 1043-1048, 2002.
 49. Takami, K., Takuwa, N., Okazaki, H., Kobayashi, M., Ohtoshi, T., Kawasaki, S., Dohi, M., Yamamoto, K., Nakamura, T., Tanaka, M., Nakahara, K., Takuwa, Y., and Takizawa, H. : Interferon-gamma Inhibits hepatocyte growth factor-stimulated cell proliferation of human bronchial epithelial cells upregulation of p27kip1 cyclin-dependent kinase inhibitor. *American Journal of Respiratory Cell & Molecular Biology*, 26(2), 231-238, 2002
 50. Takenaka, K., Suzuki, Y., Uno, K., Sato, M., Komuro, T., Haruna Y., Kobayashi, H., Kawakubo, K., Sonoda, M., Asakawa, M., Nakahara, K., and Gunji, A. : Effects of rapid saline infusion on orthostatic intolerance and automatic tone after 20 days bed rest. *Am J Cardiol* 89, 557-561, 2002.

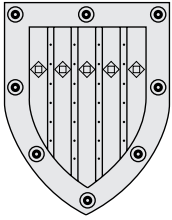

Department of Transfusion Medicine

Outline and Research Objectives

The Department of Transfusion Medicine was established in 1949, and actually is composed by 4 medical doctors, 10 medical technicians, 1 nurse and 1 office assistant.

Faculties and Students

Professor and Chair Yoichi Shibata, M.D., Ph.D. (since April 1993)

Associate Professors absent

Lecturer absent

Associate3

Research Students.....4 research students from the department of Surgical Oncology are developing their research projects at the department's laboratory.

Secretary1

Medical Technician.....10

Nurse.....1

Past Research and Major Accomplishments

The major research projects developed at the department are related to:

- 1) Human platelet antigen/antibody detection and characterization: the mixed-passive hemagglutination (MPHA) assay, a serological method largely used in Japan for the screening and characterization of platelet alloantigens and alloantibodies, was developed at the department by Yoichi Shibata. Using this method, a new platelet alloantigen system, namely the HPA-4 system (Yuka/b), was discovered by Y. Shibata, et al.
- 2) Human endothelial cell antigen/antibody detection and characterization: the MPHA method, developed by Y. Shibata, et al., was modified for the detection and characterization of endothelial cell alloantigens and alloantibodies. Using this method, monoclonal antibodies reactive with tumor endothelial cells were developed at the department. This monoclonals are being investigated for a possible application in cancer treatment.
- 3) Immunotherapy of cancer using LAK cells and dendritic cells: the effectiveness of lymphokine-activated killer (LAK) cells, as well as of peripheral blood and monocyte-derived dendritic cells for immunotherapy of cancer was investigated in

vitro, and were tested in a clinical trial for the treatment of patients with gastrointestinal cancer and brain tumors.

- 4) Development of new vaccines targeting the tumor angiogenesis for the treatment of cancer: new vaccine strategies for the treatment of solid tumors by targeting the tumor vasculature are being developed at the department. The vaccine, tested in an animal model of colon cancer metastasis, showed to be very effective, and is being prepared for the clinical trial.
- 5) Vaccination therapy of patients with habitual abortion using the husband's lymphocytes, and investigation on their mechanism of action.
- 6) Effects of radiation and filtration on platelet function: the effects of radiation and the use of white blood cell (WBC)-reduction filters on the platelet function (adhesion and aggregation) have been studied. Irradiation did not affect the platelet function, but the WBC-reduction filters, depending on the type of filter, reduced the adhesive capacity of platelets.
- 7) Development of a new methodology for the evaluation of platelet function: a new method, based on the adhesive capacity of platelets, is being developed at the department.
- 8) Peripheral blood stem cells transplantation: peripheral blood stem cells are isolated at the department for transplantation in leukemic patients.

Current Research

The research projects described above are still ongoing at the department of Transfusion Medicine, which are:

- 1) Human platelet antigen/antibody detection and characterization, and study on their role in transfusion practice;
- 2) Human endothelial cell antigen/antibody detection and characterization, and study on their role in the pathogenesis of inflammatory and autoimmune diseases, as well as in organ transplantation;
- 3) Immunotherapy of cancer using LAK cells and dendritic cells;

- 4) Development of new vaccines targeting the tumor angiogenesis for the treatment of cancer;
- 5) Lymphocyte vaccination therapy for patients with habitual abortion;
- 6) Effects of radiation and filtration on platelet function;
- 7) Development of a new methodology for the evaluation of platelet function;
Peripheral blood stem cells transplantation.

Future Prospects

The future prospects of the department are as follows:

- 1) To develop the ideal method of platelet collection and preservation for transfusion, especially related to preservation of platelets without loss of their function;
- 2) To develop a good methodology for the evaluation of platelet function;
- 3) To develop a new therapeutic strategy to combat cancer by targeting the angiogenic vasculature of tumors;
- 4) To develop the vascular regeneration medicine using peripheral blood and cord blood stem cells.

Research Grants

- (1) Grant-in-Aid for Scientific Research from the Ministry of Education, Culture, Sports, Science and Technology of Japan –Kiban (C)(2): Development of a new methodology for the detection of anti-endothelial cell antibodies and evaluation on their clinical significance. 1997 – 1998;3 million yen.
- (2) Grant-in-Aid for Scientific Research from the Ministry of Education, Culture, Sports, Science and Technology of Japan (B)(2): Development of a monoclonal antibody-based strategy for cancer treatment targeting the angiogenic vascular endothelium. 1999 – 2001;11,800 thousand yen.
- (3) Grant-in-Aid for Scientific Research from the Ministry of Education, Culture, Sports, Science and Technology of Japan- Grant for Highly-advanced Medicine, Development of a cell-based and gene-based strategies for the treatment of malignant and other life-threatening disorder of difficult control. 1998 – 2000; 131,304 thousand yen.

Select Publications

1. Osada T, Fujimaki T, Takamizawa M, Tsuno NH, Kirino T, Shibata Y. Dendritic cells activate antitumor immunity for malignant intracranial germ cell tumor: a case report. *Japanese Journal of Clinical Oncology*;31(8):403-6, 2001.
2. Osada T, Nagawa H, Kitayama J, Tsuno NH, Ishihara S, Takamizawa M, Shibata Y. Peripheral blood dendritic cells, but not monocyte-derived dendritic cells,

- can augment human NK cell function. *Cell Immunol*; 213(1):14-23, 2001.
3. Maejima M, Fujii T, Yamashita T, Hara N, Hamai Y, Miki A, Kozuma S, Okai T, Shibata Y, Taketani Y. Immunotherapy before and during pregnancy improves pregnancy outcome in women who suffer from recurrent abortion and did not benefit from immunotherapy before pregnancy. *American Journal of Reproductive Immunology*;39(1):12-5, 1998.
4. Maejima M, Fujii T, Okai T, Kozuma S, Shibata Y, Taketani Y. Beta2-glycoprotein I-dependent anticardiolipin antibody in early recurrent spontaneous abortion. *Human Reproduction*;12(10):2140-2, 1997.
5. Maejima M, Fujii T, Kozuma S, Okai T, Shibata Y, Taketani Y. Presence of HLA-G-expressing cells modulates the ability of peripheral blood mononuclear cells to release cytokines. *American Journal of Reproductive Immunology*;38(2):79-82, 1997.
6. Minchinton RM, Dawkins B, Chynoweth L, Pearson H, Lown JA, Shibata Y. In pursuit of enigmatic platelet antibodies--anti-HPA-2b and anti-HPA-3a. *Transfusion Medicine*;6(3):289-91, 1996.
7. Takeuchi F, Kuwata S, Nakano K, Nabeta H, Hong GH, Shibata Y, Tanimoto K, Ito K. Association of TAP1 and TAP2 with systemic sclerosis in Japanese. *Clinical & Experimental Rheumatology*;14(5):513-21, 1996.
8. Fujii T, Tsushima R, Okai T, Shibata Y, Taketani Y. Allo-non-specific elevation of maternal killer cell activity in intrauterine growth restriction. *International Journal of Gynaecology & Obstetrics*; 52(3):237-42, 1996.
9. Chiu L, Nishimura M, Ishii Y, Nieda M, Maeshima M, Takedani Y, Shibata Y, Tadokoro K, Juji T. Enhancement of the expression of progesterone receptor on progesterone-treated lymphocytes after immunotherapy in unexplained recurrent spontaneous abortion. *American Journal of Reproductive Immunology*;35(6):552-7, 1996.
10. Sunami E, Tsuno NH, Kitayama J, Osada T, Saito S, Tomozawa S, Tsuruo T, Shibata Y, Nagawa H. Decreased Synthesis of MMP-7 and Adhesion to Extracellular Matrix Proteins of Human Colon Cancer Cells Treated with Troglitazone. *Surgery Today* 2001
11. Tomozawa S, Tsuno NH, Sunami E, Hatano K, Kitayama J, Osada T, Saito S, Tsuruo T, Shibata Y, Nagawa H. Cyclooxygenase-2 overexpression correlates with tumour recurrence, especially haematogenous metastasis, of colorectal cancer. *Br J Cancer*; 83(3):324-328, 2000.
12. Sunami E, Tsuno N, Osada T, Saito S, Kitayama J, Tomozawa S, Tsuruo T, Shibata Y, Muto T, Nagawa H. MMP-1 is a prognostic marker for hematogenous metastasis of colorectal cancer. *Oncologist*;5(2):108-14, 2000.
13. Saito S, Tsuno N, Nagawa H, Sunami E, Zhengxi J, Osada T, Kitayama J, Shibata Y, Tsuruo T, Muto T. Expression of platelet-derived endothelial cell growth factor correlates with good prognosis in

patients with colorectal carcinoma. *Cancer* Jan 1;88(1):42-9, 2000.

14. Tomozawa S, Nagawa H, Tsuno N, Hatano K, Osada T, Kitayama J, Sunami E, Nita ME, Ishihara S, Yano H, Tsuruo T, Shibata Y, Muto T. Inhibition of haematogenous metastasis of colon cancer in mice by a selective COX-2 inhibitor, JTE-522. *British Journal of Cancer*; 81(8):1274-9, 1999.

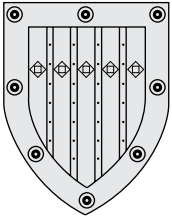

Department of Obstetrics and Gynecology

Outline and Research Objectives

The goal we aim at is the improvement of holistic women's health. To achieve it, we integrate all the knowledge in the field of reproductive medicine, perinatal medicine and gynecological oncology, which has been established on the basis of our history more than hundred years, and will develop them.

Faculties and Students

Professor and Chair	Yuji Taketani, MD, PhD (from 1994)
Associate Professor	Shiro Kozuma
Lecturer	Toshiyuki Kojima Koji Kugu
Associate	15
Postdoctoral Fellow	2
Graduate Student.....	2
Research Student	15
Secretary	2

Past Research and Major Accomplishments

Professor Taketani has led the clinical and basic research on reproductive endocrinology in Japan. Especially, he is the distinguished leader in the research field of endometriosis, and has achieved many valuable studies. He has also conducted the research which went into the broad range in obstetrics and gynecology by his prominent leadership in the department. There are more than 250 papers which he directed in these two decades.

Current Research

We have a highly organized infertility clinic, where every patient is systemically examined and after diagnosis of underlying infertility factor(s) appropriate treatment is performed following our protocol. Once it turns out higher level of treatment is necessary, ART is applied to such cases. We have been engaged in in vitro fertilization and embryo transfer (IVF-ET) as a main axis of ART for fifteen years. Conventional IVF-ET is mainly indicated to cases with tubal factor, mild male factor, immunological factor or of unexplained infertility factor. In case of severe male factor or other fertilization disorder intracytoplasmic sperm injection (ICSI) is performed. Now we have about 300 cases of IVF-ET every year, which conventional IVF-ET and ICSI share almost equally. The pregnancy rate of conventional IVF-ET is around 25% per embryo

transfer cycle, which is comparable with that of ICSI. Other ART techniques such as embryo cryopreservation and assisted zona hatching are also under way.

Total number of delivery cases is 426 per year. Recently cases of obstetrical emergencies like abruptio placentae, eclampsia and uterine ruptures transported from neighboring hospitals have been increasing. Our service is an important part of Tokyo Metropolitan Service System for Maternal Welfare and Perinatal Medicine.

Primary care for peri/post-menopausal women is becoming more and more important. We have already established the primary care system for women focusing on climacteric syndrome and osteoporosis. Hormone replacement therapy (HRT) is employed for the purpose.

In basic research section, a couple of projects as follows are under way, some of which have already yielded interesting findings; 1) the mechanism of folliculogenesis and follicular apoptosis in the ovary, 2) the functions of gynecologic hormones such as gonadotropins and ovarian steroids, 3) the biochemical evaluation of early embryos and establishment of a new procedure of embryo cryopreservation, 4) the genetic mechanism in gamete formation and development and 5) effect of sex steroid on bone metabolism.

Future Prospects

To improve the pregnancy rate in the infertility clinic, the basic research on both the embryo and the endometrium, ovarian function and its regulatory mechanism must be proceed. To take the precautions in the infertility treatment, the development of the safe protocol and secure system is also demanded.

The validity of hormone replacement therapy for managing peri/post-menopausal women is becoming a subject of discussion. To seek the answer this problem, we are studying on the various protocols in clinical and by experiments.

In the obstetrical field, the researches on the immunological fetomaternal interaction are going on.

In vivo study of fetal physiology using sheep model are in progress, expected to provide valuable knowledge for clinical field.

Research Grants

Grant-in-Aid for Scientific Research, Japan Society for the Promotion of Science: Scientific Research (A) "Mechanism of conception in terms of embryo-maternal interaction" (1999-2001)

Grant-in-Aid for Scientific Research, Japan Society for the Promotion of Science: Scientific Research (B) "Risk factors associated with progression and recurrence of endometriosis" (2000-2002)

Grant-in-Aid for Scientific Research, Ministry of Health and Welfare: "Status of endometriosis in Japan in terms of reproductive health" (1998)

Grant-in-Aid for Scientific Research, Ministry of Health, Labor and Welfare: "Strategy for reproductive health-keeping of women with menstrual disorders" (1999-2000)

Grant-in-Aid for Scientific Research, Ministry of Health, Labor and Welfare: "Status of reproductive health of women with reproductive disorders in the society" (2001-2002)

Select Publications (most recent 50 papers)

- Hiroi H, Momoeda M, Yamauchi N, Abe Y, Yoshikawa H, Tsutsumi O and Taketani Y. An earlier menopause as clinical manifestation of granulosa-cell tumor: a case report. *J Obstet Gynaecol Res* 26, 9-12, 2000.
- Hyodo H, Ishikawa Y, Tsuneyama H, Kashiwase K, Toyoda C, Uchikawa M, Akaza T, Fujii T, Kozuma S, Taketani Y and Juji T. New RhD(IVb) identified in Japanese. *Vox Sang* 79, 116-7, 2000.
- Hyodo H, Ishikawa Y, Kashiwase K, Ogawa A, Watanabe Y, Tsuneyama H, Toyoda C, Uchikawa M, Akaza T, Fujii T, Kozuma S, Taketani Y and Juji T. Polymorphisms of RhD(Va) and a new RhD(Va)-like variant found in Japanese individuals. *Vox Sang* 78, 122-5, 2000.
- Kamei Y, Takeda Y, Teramoto K, Tsutsumi O, Taketani Y and Watanabe K. Human NB-2 of the contactin subgroup molecules: chromosomal localization of the gene (CNTN5) and distinct expression pattern from other subgroup members. *Genomics* 69, 113-9, 2000.
- Koga K, Osuga Y, Tsutsumi O, Okagaki R, Momoeda M, Yano T, Fujiwara T, Takai Y, Kugu K, Morita Y and Taketani Y. Increased concentrations of soluble tumour necrosis factor receptor (sTNFR) I and II in peritoneal fluid from women with endometriosis. *Mol Hum Reprod* 6, 929-33, 2000.
- Koga K, Osuga Y, Tsutsumi O, Momoeda M, Suenaga A, Kugu K, Fujiwara T, Takai Y, Yano T and Taketani Y. Evidence for the presence of angiogenin in human follicular fluid and the up-regulation of its production by human chorionic gonadotropin and hypoxia. *J Clin Endocrinol Metab* 85, 3352-5, 2000.
- Kuroda K, Kamei Y, Kozuma S, Kikuchi A, Fujii T, Unno N, Baba K and Taketani Y. Cephalopagus conjoined twins. *Ultrasound Obstet Gynecol* 16, 293, 2000.
- Kuroda K, Kamei Y, Kozuma S, Kikuchi A, Fujii T, Unno N, Baba K and Taketani Y. Prenatal evaluation of cephalopagus conjoined twins by means of three-dimensional ultrasound at 13 weeks of pregnancy. *Ultrasound Obstet Gynecol* 16, 264-6, 2000.
- Matsumi H, Yano T, Osuga Y, Kugu K, Tang X, Xu JP, Yano N, Kurashima Y, Ogura T, Tsutsumi O, Koji T, Esumi H and Taketani Y. Regulation of nitric oxide synthase to promote cytotaxis in ovarian follicular development. *Biol Reprod* 63, 141-6, 2000.
- Matsumoto K, Yoshikawa H, Nakagawa S, Tang X, Yasugi T, Kawana K, Sekiya S, Hirai Y, Kukimoto I, Kanda T and Taketani Y. Enhanced oncogenicity of human papillomavirus type 16 (HPV16) variants in Japanese population. *Cancer Lett* 156, 159-65, 2000.
- Matsumoto K, Kawana K, Yoshikawa H, Taketani Y, Yoshiike K and Kanda T. DNA vaccination of mice with plasmid expressing human papillomavirus 6 major capsid protein L1 elicits type-specific antibodies neutralizing pseudovirions constructed in vitro. *J Med Virol* 60, 200-4, 2000.
- Miki A, Fujii T, Ishikawa Y, Hamai Y, Yamashita T, Tadokoro K, Kozuma S, Juji T and Taketani Y. Immunotherapy prevents recurrent abortion without influencing natural killer receptor status. *Am J Reprod Immunol* 43, 98-106, 2000.
- Nakagawa S, Yoshikawa H, Yasugi T, Kimura M, Kawana K, Matsumoto K, Yamada M, Onda T and Taketani Y. Ubiquitous presence of E6 and E7 transcripts in human papillomavirus-positive cervical carcinomas regardless of its type. *J Med Virol* 62, 251-8, 2000.
- Osuga Y, Koga K, Tsutsumi O, Igarashi T, Okagaki R, Takai Y, Matsumi H, Hiroi H, Fujiwara T, Momoeda M, Yano T and Taketani Y. Stem cell factor (SCF) concentrations in peritoneal fluid of women with or without endometriosis. *Am J Reprod Immunol* 44, 231-5, 2000.
- Wang Y, Yano T, Kikuchi A, Yano N, Matsumi H, Ando K, Kasai Y, Watanabe M, Okagaki R, Osuga Y and Taketani Y. Comparison of the effects of add-back therapy with various natural oestrogens on bone metabolism in rats administered a long-acting gonadotrophin-releasing hormone agonist. *J Endocrinol* 165, 467-73, 2000.
- Yano T, Radulovic S, Osuga Y, Kugu K, Yoshikawa H, Taketani Y and Schally AV. Inhibition of human epithelial ovarian cancer cell growth in vitro by somatostatin analog RC-160. *Oncology* 59 Suppl 1, 45-9, 2000.
- Yoshida S, Unno N, Kagawa H, Shinozuka N, Kozuma S and Taketani Y. Prenatal detection of a high-risk group for intrauterine growth restriction

- based on sonographic fetal biometry. *Int J Gynaecol Obstet* 68, 225-32, 2000.
18. Yoshikawa H, Jimbo H, Okada S, Matsumoto K, Onda T, Yasugi T and Taketani Y. Prevalence of endometriosis in ovarian cancer. *Gynecol Obstet Invest* 50 Suppl 1, 11-7, 2000.
 19. Hiroi H, Kugu K, Hoshino H, Kozuma S and Taketani Y. Hyperemesis gravidarum associated with thyrotoxicosis and a past history of an eating disorder. *Arch Gynecol Obstet* 265, 228-30, 2001.
 20. Hiroi H, Yasugi T, Matsumoto K, Fujii T, Watanabe T, Yoshikawa H and Taketani Y. Mucinous adenocarcinoma arising in a neovagina using the sigmoid colon thirty years after operation: a case report. *J Surg Oncol* 77, 61-4, 2001.
 21. Kanai T, Fujii T, Keicho N, Tokunaga K, Yamashita T, Hyodo H, Miki A, Unno N, Kozuma S and Taketani Y. Polymorphism of human leukocyte antigen-E gene in the Japanese population with or without recurrent abortion. *Am J Reprod Immunol* 45, 168-73, 2001.
 22. Kanai T, Fujii T, Unno N, Yamashita T, Hyodo H, Miki A, Hamai Y, Kozuma S and Taketani Y. Human leukocyte antigen-G-expressing cells differently modulate the release of cytokines from mononuclear cells present in the decidua versus peripheral blood. *Am J Reprod Immunol* 45, 94-9, 2001.
 23. Kanai T, Fujii T, Kozuma S, Yamashita T, Miki A, Kikuchi A and Taketani Y. Soluble HLA-G influences the release of cytokines from allogeneic peripheral blood mononuclear cells in culture. *Mol Hum Reprod* 7, 195-200, 2001.
 24. Kawana K, Kawana Y, Yoshikawa H, Taketani Y, Yoshiike K and Kanda T. Nasal immunization of mice with peptide having a cross-neutralization epitope on minor capsid protein L2 of human papillomavirus type 16 elicit systemic and mucosal antibodies. *Vaccine* 19, 1496-502, 2001.
 25. Kawana Y, Kawana K, Yoshikawa H, Taketani Y, Yoshiike K and Kanda T. Human papillomavirus type 16 minor capsid protein L2 N-terminal region containing a common neutralization epitope binds to the cell surface and enters the cytoplasm. *J Virol* 75, 2331-6, 2001.
 26. Koga K, Osuga Y, Tsutsumi O, Yano T, Yoshino O, Takai Y, Matsumi H, Hiroi H, Kugu K, Momoeda M, Fujiwara T and Taketani Y. Demonstration of angiogenin in human endometrium and its enhanced expression in endometrial tissues in the secretory phase and the decidua. *J Clin Endocrinol Metab* 86, 5609-14, 2001.
 27. Kugu K, Momoeda M, Sharma SS, Osuga Y, Fujiwara T, Okagaki R, Fukushima H, Yano T, Tsutsumi O and Taketani Y. Is an elevation in basal follicle-stimulating hormone levels in unexplained infertility predictive of fecundity regardless of age? *Endocr J* 48, 711-5, 2001.
 28. Marumo G, Kozuma S, Ohyu J, Hamai Y, Machida Y, Kobayashi K, Ryo E, Unno N, Fujii T, Baba K, Okai T, Takashima S and Taketani Y. Generation of periventricular leukomalacia by repeated umbilical cord occlusion in near-term fetal sheep and its possible pathogenetical mechanisms. *Biol Neonate* 79, 39-45, 2001.
 29. Minaguchi T, Yoshikawa H, Oda K, Ishino T, Yasugi T, Onda T, Nakagawa S, Matsumoto K, Kawana K and Taketani Y. PTEN mutation located only outside exons 5, 6, and 7 is an independent predictor of favorable survival in endometrial carcinomas. *Clin Cancer Res* 7, 2636-42, 2001.
 30. Osuga Y, Koga K, Tsutsumi O, Yano T, Kugu K, Momoeda M, Okagaki R, Suenaga A, Fujiwara T, Fujimoto A, Matsumi H, Hiroi H and Taketani Y. Evidence for the presence of keratinocyte growth factor (KGF) in human ovarian follicles. *Endocr J* 48, 161-6, 2001.
 31. Ryo E, Shiotsu H, Takai Y, Tsutsumi O, Okai T, Taketani Y and Takeuchi Y. Effects of pulsed ultrasound on development and glucose uptake of preimplantation mouse embryos. *Ultrasound Med Biol* 27, 999-1002, 2001.
 32. Ryo E, Yorinaga Y, Nagasaka T, Yoshikawa H and Taketani Y. Tumor cell spillage to the vaginal cavity and vaginal stump during the surgery of endometrial carcinoma. *Acta Obstet Gynecol Scand* 80, 364-7, 2001.
 33. Tsuchiya F, Ikeda K, Tsutsumi O, Hiroi H, Momoeda M, Taketani Y, Muramatsu M and Inoue S. Molecular cloning and characterization of mouse EBAG9, homolog of a human cancer associated surface antigen: expression and regulation by estrogen. *Biochem Biophys Res Commun* 284, 2-10, 2001.
 34. Uemura H, Unno N, Osuga Y, Momoeda M, Ando K, Marumo G, Kikuchi A, Fujii T, Kozuma S and Taketani Y. A movable gestational sac in association with a myometrial defect. *Ultrasound Obstet Gynecol* 18, 675-7, 2001.
 35. Xin CY, Matsumoto K, Yoshikawa H, Yasugi T, Onda T, Nakagawa S, Yamada M, Nozawa S, Sekiya S, Hirai Y, Shiromizu K, Fujii T and Taketani Y. Analysis of E6 variants of human papillomavirus type 33, 52 and 58 in Japanese women with cervical intraepithelial neoplasia/cervical cancer in relation to their oncogenic potential. *Cancer Lett* 170, 19-24, 2001.
 36. Yoshida SH, Unno N, Kagawa H, Shinozuka N, Kozuma S and Taketani Y. Sonographic determination of fetal size from 20 weeks of gestation onward correlates with birth weight. *J Obstet Gynaecol Res* 27, 205-11, 2001.
 37. Yoshino O, Osuga Y, Koga K, Tsutsumi O, Yano T, Fujii T, Kugu K, Momoeda M, Fujiwara T, Tomita K and Taketani Y. Evidence for the expression of interleukin (IL)-18, IL-18 receptor and IL-18 binding protein in the human endometrium. *Mol Hum Reprod* 7, 649-54, 2001.
 38. Fujimoto A, Osuga Y, Yano T, Kusumi M, Kurosawa T, Fujii T and Taketani Y. Ovarian hyperstimulation syndrome complicated by peritonitis due to perforated appendicitis. *Hum Reprod* 17, 966-7, 2002.

39. Hashimoto K, Kato K, Imamura K, Kishimoto A, Yoshikawa H, Taketani Y and Esumi H. 5-amino-4-imidazolecarboxamide riboside confers strong tolerance to glucose starvation in a 5'-AMP-activated protein kinase-dependent fashion. *Biochem Biophys Res Commun* 290, 263-7, 2002.
40. Hasumi Y, Mizukami H, Urabe M, Kohno T, Takeuchi K, Kume A, Momoeda M, Yoshikawa H, Tsuruo T, Shibuya M, Taketani Y and Ozawa K. Soluble FLT-1 expression suppresses carcinomatous ascites in nude mice bearing ovarian cancer. *Cancer Res* 62, 2019-23, 2002.
41. Hiroi H, Osuga Y, Tarumoto Y, Shimokama T, Yano T, Yokota H and Taketani Y. A case of estrogen-producing Brenner tumor with a stromal component as a potential source for estrogen. *Oncology* 63, 201-4, 2002.
42. Horie K, Tomida A, Sugimoto Y, Yasugi T, Yoshikawa H, Taketani Y and Tsuruo T. SUMO-1 conjugation to intact DNA topoisomerase I amplifies cleavable complex formation induced by camptothecin. *Oncogene* 21, 7913-22, 2002.
43. Kawana K, Yasugi T, Kanda T, Kawana Y, Hirai Y, Yoshikawa H and Taketani Y. Neutralizing antibodies against oncogenic human papillomavirus as a possible determinant of the fate of low-grade cervical intraepithelial neoplasia. *Biochem Biophys Res Commun* 296, 102-5, 2002.
44. Matsumoto K, Yoshikawa H, Yasugi T, Onda T, Nakagawa S, Yamada M, Kawana K, Minaguchi T, Oda K, Hasumi Y and Taketani Y. Distinct lymphatic spread of endometrial carcinoma in comparison with cervical and ovarian carcinomas. *Cancer Lett* 180, 83-9, 2002.
45. Momoeda M, Taketani Y, Terakawa N, Hoshiai H, Tanaka K, Tsutsumi O, Osuga Y, Maruyama M, Harada T, Obata K and Hayashi K. Is endometriosis really associated with pain? *Gynecol Obstet Invest* 54 Suppl 1, 18-23, 2002.
46. Okada S, Tsuda H, Takarabe T, Yoshikawa H, Taketani Y and Hirohashi S. Allelotype Analysis of Common Epithelial Ovarian Cancers with Special Reference to Comparison between Clear Cell Adenocarcinoma with Other Histological Types. *Jpn J Cancer Res* 93, 798-806, 2002.
47. Osuga Y, Yano T, Kugu K, Koga K, Fukuoka K, Matsumi H, Wada O, Kikuchi A, Tsutsumi O and Taketani Y. Effects of gonadotropin-releasing hormone analog treatment on skin condition. *Gynecol Endocrinol* 16, 57-61, 2002.
48. Tang X, Yano T, Osuga Y, Matsumi H, Yano N, Xu J, Wada O, Koga K, Kugu K, Tsutsumi O, Schally AV and Taketani Y. Cellular mechanisms of growth inhibition of human epithelial ovarian cancer cell line by LH-releasing hormone antagonist Cetrorelix. *J Clin Endocrinol Metab* 87, 3721-7, 2002.
49. Xu J, Osuga Y, Yano T, Morita Y, Tang X, Fujiwara T, Takai Y, Matsumi H, Koga K, Taketani Y and Tsutsumi O. Bisphenol A induces apoptosis and G2-to-M arrest of ovarian granulosa cells. *Biochem Biophys Res Commun* 292, 456-62, 2002.
50. Zhang SQ, Kozuma S, Tanaka M, Ling D, Kitano Y, Fujii T, Baba K and Taketani Y. Studies on fetal forelimb movements by using a wrist actigraph in sheep. *Psychiatry Clin Neurosci* 56, 283-4, 2002.

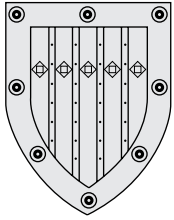

Department of Gynecologic Surgery

Outline and Research Objectives

Our department was established for development of effective and safe gynecologic surgery on the basis of knowledge in reproductive medicine and gynecologic oncology.

Faculties and Students

Professor and Chair:	Osamu Tsutsumi, MD, PhD (from 2001)
Associate Professor:	Tetsu Yano
Lecturer:	Osamu Nishii Tomoyuki Fujii
Associate:2
Postdoctoral Fellow:2
Graduate Student:2
Research Student:5
Secretary:2

Past Research and Major Accomplishments

Professor Tsutsumi has been very actively working on both clinical and basic research in our department even before becoming Professor in 2001. In the clinical field, he conducted endoscopic surgery as the first person in gynecology. As for the basic research, many achievements were left so far in the embryogenesis, the genetics and the reproductive endocrinology.

Current Research

For the benign gynecological disorders, we have been constantly trying to minimize surgical invasion to patients as much as possible. With both of well-equipped instruments and well-trained expertise, more than 90% of surgeries for benign gynecological disorders are operated endoscopically, which make a total of 300 cases per year. On the other hand, various projects concerning treatment of gynecological malignancies and sexually transmitted viral infections are on-going. To improve the prognosis of gynecological malignancy, we are conducting the studies, including 1) Prognostic significance of pelvic and paraaortic lymphnode metastasis in the uterine cervical cancer, 2) application of chemotherapy (BLM + VCR + MMC + CDDP) for advanced or recurrent cervical cancer, 3) incidence and distribution of PLN and PALN metastasis in endometrial cancer, 4) relationship between the presence of estrogen and progesterone receptor and clinical course in endometrial cancer, 5) development

of optimal surgical procedure for advanced ovarian cancer, 6) impacts of aggressive debulking (including bowel resection) on the prognosis of advanced ovarian cancer, 7) analysis of long term prognosis of ovarian cancer patients treated with paclitaxel containing chemotherapy, 8) analysis of adverse effects of CDDP-based chemotherapy, focused on nephrotoxicity and neurotoxicity, 9) effect of intermittent consolidation chemotherapy for advanced ovarian cancer, 10) evaluation of sensitivity and specificity of serum CA125 level assay and ultrasonographic follow-up for diagnosis of recurrent ovarian cancer, 11) trans-arterial chemotherapy for parenchymal liver metastasis of ovarian cancer, 12) estimation of effects of a combination chemotherapy (hydroxyurea + etoposide + DTIC) for uterine sarcomas, 13) cohort study of low-grade CIN.

In basic research section, the studies are on going on the effect of endocrine disrupters on the reproductive system, embryogenesis and oncogenesis.

Future Prospects

As well as proceeding the studies mentioned above, we are starting the project on developing vaccine against HPVs, using neutralizing epitope of HPV-16 capsid proteins L1 and L2 (L1/L2 capsids).

Research Grants

1. Grant-in-Aid for Core Research for Evolutional Science and Technology, Japan Science and Thechnology Corporation: "Effect of endocrine disrupters on reproductive functions" (1998-2003)
2. Grant-in-Aid for Scientific Research, Japan Society for the Promotion of Science: Scientific Research (B) "Effect of endocrine disrupters on reproductive functions" (1999-2001)
3. Grant-in-Aid for Scientific Research, Japan Society for the Promotion of Science: Scientific Research (B) "Effect of endocrine disrupters on reproductive functions" (2002-2004)
4. Grant-in-Aid for Scientific Research, Ministry of Health, Labor and Welfare: "Effect of endocrine disrupters on reproductive health" (1998-2000)

5. Grant-in-Aid for Scientific Research, Ministry of Health, Labor and Welfare: "Effect of endocrine disrupters on reproductive health" (2001-2002)

Select Publications

1. Tsutsumi O, Kurachi H and Oka T. A physiological role of epidermal growth factor in male reproductive function. *Science* 233, 975-7, 1986.
2. Tsutsumi O, Kubota Y and Oka T. Effect of sialoadenectomy, treatment with epidermal growth factor (EGF) antiserum and replacement of EGF on the epidermis in mice. *J Endocrinol* 113, 193-7, 1987.
3. Tsutsumi O and Oka T. Epidermal growth factor deficiency during pregnancy causes abortion in mice. *Am J Obstet Gynecol* 156, 241-4, 1987.
4. Tsutsumi O, Tsutsumi A and Oka T. Importance of epidermal growth factor in implantation and growth of mouse mammary tumor in female nude mice. *Cancer Res* 47, 4651-3, 1987.
5. Tsutsumi O, Tsutsumi A and Oka T. A possible physiological role of milk epidermal growth factor in neonatal eyelid opening. *Am J Physiol* 252, R376-9, 1987.
6. Tsutsumi O, Tsutsumi A and Oka T. Epidermal growth factor-like, corneal wound healing substance in mouse tears. *J Clin Invest* 81, 1067-71, 1988.
7. Tsutsumi O, Yano T, Satoh K, Mizuno M and Kato T. Studies of hexokinase activity in human and mouse oocyte. *Am J Obstet Gynecol* 162, 1301-4, 1990.
8. Tsutsumi O, Satoh K, Taketani Y and Kato T. Determination of enzyme activities of energy metabolism in the maturing rat oocyte. *Mol Reprod Dev* 33, 333-7, 1992.
9. Sadatsuki M, Tsutsumi O, Yamada R, Muramatsu M and Taketani Y. Local regulatory effects of activin A and follistatin on meiotic maturation of rat oocytes. *Biochem Biophys Res Commun* 196, 388-95, 1993.
10. Sadatsuki M, Tsutsumi O, Sakai R, Eto Y, Hayashi N and Taketani Y. Presence and possible function of activin-like substance in human follicular fluid. *Hum Reprod* 8, 1392-5, 1993.
11. Tsutsumi O, Iida T, Hakuno N, Sadatsuki M, Okai T, Taketani Y, Nagafuchi S and Nakahori Y. Y chromosome analysis and laparoscopic surgery in XY pure gonadal dysgenesis: a case report and a review of literature. *Asia Oceania J Obstet Gynaecol* 19, 95-9, 1993.
12. Tsutsumi O, Taketani Y and Oka T. The uterine growth-promoting action of epidermal growth factor and its function in the fertility of mice. *J Endocrinol* 138, 437-44, 1993.
13. Tsutsumi O, Taketani Y and Oka T. Evidence for the involvement of epidermal growth factor in fertility decline in aging female mice. *Horm Res* 39 Suppl 1, 32-6, 1993.
14. Ayabe T, Tsutsumi O and Taketani Y. Hexokinase activity in mouse embryos developed in vivo and in vitro. *Hum Reprod* 9, 347-51, 1994.
15. Morita Y, Tsutsumi O and Taketani Y. In vitro treatment of embryos with epidermal growth factor improves viability and increases the implantation rate of blastocysts transferred to recipient mice. *Am J Obstet Gynecol* 171, 406-9, 1994.
16. Tsutsumi O, Iida T, Taketani Y, Sugase M, Nakahori Y and Nakagome Y. Intact sex determining region Y (SRY) in a patient with XY pure gonadal dysgenesis and a twin brother. *Endocr J* 41, 281-5, 1994.
17. Tsutsumi O, Yano T and Taketani Y. Phosphofructokinase activity as a measure of maturation of rat oocytes developed in vivo and in vitro. *Horm Res* 41 Suppl 1, 63-7, 1994.
18. Morita Y, Tsutsumi O and Taketani Y. Successful treatment of catamenial pneumothorax with danazol. *Int J Gynaecol Obstet* 51, 263-4, 1995.
19. Tsutsumi O, Iida T and Taketani Y. Laparoscopic surgery and DNA analysis in patients with XY pure gonadal dysgenesis. *J Obstet Gynaecol* 21, 67-74, 1995.
20. Morita Y, Tsutsumi O, Kuramochi K, Momoeda M, Yoshikawa H and Taketani Y. Successful laparoscopic management of primary abdominal pregnancy. *Hum Reprod* 11, 2546-7, 1996.
21. Takai Y, Ogawara M, Tomono Y, Moritoh C, Imajoh-Ohmi S, Tsutsumi O, Taketani Y and Inagaki M. Mitosis-specific phosphorylation of vimentin by protein kinase C coupled with reorganization of intracellular membranes. *J Cell Biol* 133, 141-9, 1996.
22. Tsutsumi O, Iida T, Nakahori Y and Taketani Y. Analysis of the testis-determining gene SRY in patients with XY gonadal dysgenesis. *Horm Res* 46 Suppl 1, 6-10, 1996.
23. Tsutsumi O and Yoshimura Y. Sex differentiation and ovarian function. An overview. *Horm Res* 46 Suppl 1, 1-5, 1996.
24. Kawana K, Yoshikawa H, Yokota H, Onda T, Nakagawa K, Tsutsumi O and Taketani Y. Successful treatment of brain metastases from ovarian cancer using gamma-knife radiosurgery. *Gynecol Oncol* 65, 357-9, 1997.
25. Morita Y, Tsutsumi O and Taketani Y. Successful hormonal treatment of pulmonary parenchymal endometriosis. *Int J Gynaecol Obstet* 59, 61-3, 1997.
26. Morita Y, Tsutsumi O, Momoeda M and Taketani Y. Cornual pregnancy successfully treated laparoscopically with fibrin glue hemostasis. *Obstet Gynecol* 90, 685-7, 1997.
27. Sadatsuki M, Kaneko M and Tsutsumi O. Expectant management and methotrexate treatment of persistent ectopic pregnancy following laparoscopic salpingectomy. *Int J Gynaecol Obstet* 59, 49-51, 1997.
28. Tsutsumi O, Ando K and Momoeda M. Ruptured isthmal pregnancy following laparoscopic salpingostomy in the ipsilateral tube. *Int J Gynaecol Obstet* 57, 187-9, 1997.
29. Uechi H, Tsutsumi O, Morita Y and Taketani Y. Cryopreservation of mouse embryos affects later embryonic development possibly through reduced

- expression of the glucose transporter GLUT1. *Mol Reprod Dev* 48, 496-500, 1997.
30. Takai Y, Tsutsumi O, Harada I, Fujii T, Kashima T, Kobayashi K, Toda T and Taketani Y. Prenatal diagnosis of Fukuyama-type congenital muscular dystrophy by microsatellite analysis. *Hum Reprod* 13, 320-3, 1998.
 31. Tsutsumi O, Uechi H, Sone H, Yonemoto J, Takai Y, Momoeda M, Tohyama C, Hashimoto S, Morita M and Taketani Y. Presence of dioxins in human follicular fluid: their possible stage-specific action on the development of preimplantation mouse embryos. *Biochem Biophys Res Commun* 250, 498-501, 1998.
 32. Igarashi T, Osuga U, Tsutsumi O, Momoeda M, Ando K, Matsumi H, Takai Y, Okagaki R, Hiroi H, Fujiwara O, Yano T and Taketani Y. Expression of Ah receptor and dioxin-related genes in human uterine endometrium in women with or without endometriosis. *Endocr J* 46, 765-72, 1999.
 33. Okagaki R, Osuga Y, Momoeda M, Tsutsumi O and Taketani Y. Laparoscopic findings after ultrasound-guided transvaginal ethanol sclerotherapy for ovarian endometrial cyst. *Hum Reprod* 14, 270, 1999.
 34. Takai Y, Tsutsumi O, Momoeda M, Osuga Y, Sadatsuki M, Kaibara M and Taketani Y. Non-functioning pituitary tumour after long-term treatment with gonadotrophin-releasing hormone agonists in a patient with vaginal agenesis who underwent neovaginoplasty and cauterization of endometriosis under laparoscopy. *Hum Reprod* 14, 2661-4, 1999.
 35. Uechi H, Tsutsumi O, Morita Y, Takai Y and Taketani Y. Comparison of the effects of controlled-rate cryopreservation and vitrification on 2-cell mouse embryos and their subsequent development. *Hum Reprod* 14, 2827-32, 1999.
 36. Maruyama M, Osuga Y, Momoeda M, Yano T, Tsutsumi O and Taketani Y. Pregnancy rates after laparoscopic treatment. Differences related to tubal status and presence of endometriosis. *J Reprod Med* 45, 89-93, 2000.
 37. Morita Y, Nishii O, Kido M and Tsutsumi O. Parvovirus infection after laparoscopic hysterectomy using fibrin glue hemostasis. *Obstet Gynecol* 95, 1026, 2000.
 38. Takai Y, Tsutsumi O, Ikezuki Y, Hiroi H, Osuga Y, Momoeda M, Yano T and Taketani Y. Estrogen receptor-mediated effects of a xenoestrogen, bisphenol A, on preimplantation mouse embryos. *Biochem Biophys Res Commun* 270, 918-21, 2000.
 39. Takai Y, Tsutsumi O, Harada I, Morita Y, Momoeda M, Fukushima Y and Taketani Y. A case of XY pure gonadal dysgenesis with 46,XYp-/47,XXYp- karyotype whose gonadoblastoma was removed laparoscopically. *Gynecol Obstet Invest* 50, 166-9, 2000.
 40. Takeuchi T and Tsutsumi O. Basal leptin concentrations in women with normal and dysfunctional ovarian conditions. *Int J Gynaecol Obstet* 69, 127-33, 2000.
 41. Tsutsumi O, Momoeda M, Takai Y, Ono M and Taketani Y. Breast-fed infants, possibly exposed to dioxins in milk, have unexpectedly lower incidence of endometriosis in adult life. *Int J Gynaecol Obstet* 68, 151-3, 2000.
 42. Fujimoto A, Osuga Y, Tsutsumi O, Fujii T, Okagaki R and Taketani Y. Successful laparoscopic treatment of ileo-cecal endometriosis producing bowel obstruction. *J Obstet Gynaecol Res* 27, 221-3, 2001.
 43. Morita Y, Tsutsumi O and Taketani Y. Regulatory mechanisms of female germ cell apoptosis during embryonic development. *Endocr J* 48, 289-301, 2001.
 44. Osuga Y, Tsutsumi O, Fujiwara T, Kugu K, Fujimoto A and Taketani Y. Usefulness of long-jaw forceps in laparoscopic cornual resection of interstitial pregnancies. *J Am Assoc Gynecol Laparosc* 8, 429-32, 2001.
 45. Takai Y, Tsutsumi O, Ikezuki Y, Kamei Y, Osuga Y, Yano T and Taketani Y. Preimplantation exposure to bisphenol A advances postnatal development. *Reprod Toxicol* 15, 71-4, 2001.
 46. Ikezuki Y, Tsutsumi O, Takai Y, Kamei Y and Taketani Y. Determination of bisphenol A concentrations in human biological fluids reveals significant early prenatal exposure. *Hum Reprod* 17, 2839-41, 2002.
 47. Kurosawa T, Hiroi H, Tsutsumi O, Ishikawa T, Osuga Y, Fujiwara T, Inoue S, Muramatsu M, Momoeda M and Taketani Y. The activity of bisphenol A depends on both the estrogen receptor subtype and the cell type. *Endocr J* 49, 465-71, 2002.
 48. Nakagawa S, Koga K, Kugu K, Tsutsumi O and Taketani Y. The evaluation of the sentinel node successfully conducted in a case of malignant melanoma of the vagina. *Gynecol Oncol* 86, 387-9, 2002.
 49. Osuga Y, Koga K, Tsutsumi O, Yano T, Maruyama M, Kugu K, Momoeda M and Taketani Y. Role of laparoscopy in the treatment of endometriosis-associated infertility. *Gynecol Obstet Invest* 53 Suppl 1, 33-9, 2002.
 50. Takeuchi T and Tsutsumi O. Serum bisphenol A concentrations showed gender differences, possibly linked to androgen levels. *Biochem Biophys Res Commun* 291, 76-8, 2002.

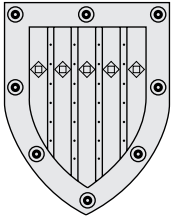

Department of Pediatrics / Developmental Pediatrics

Outline and Research Objectives

Department of Pediatrics was founded in 1889 and continued its activity for 113 years. This is the oldest Pediatrics and has been the leader of Pediatrics in Japan. Many pediatricians received the training in our department and went to all over and out of Japan and worked as a leader of pediatrician in a lot of Japanese Medical School in the University, central and local hospitals and clinics.

The health problems of children and youth have changed historically in Japan. In the late 19th century, one of five children died as infectious diseases such as dysentery, pneumonia, diphtheria, and whooping cough. Now, few children die due to the diseases. The leading causes of death for children are perinatal problems for babies, injuries, congenital anomalies, malignant neoplasms, and congenital heart diseases. Many of these diseases have genetic background in their pathogenesis. Thus, the research objectives have greatly changed. Now, they are to clarify the molecular pathogenesis of these difficult diseases and to find safe and effective therapies for them and to find the way to promote the body and heart health of children in our Pediatrics.

Pediatrics covers all the issues in children and youth. Thus, our department studies almost all the issues about children and youth. Now, we have six active study groups such as Nephrology, Hematology and Oncology, Cardiology, Immunology and Allergy, Endocrinology and Metabolism, and Neurology. The main subjects of the research are 1) Identification of the molecular pathogenesis of renal tubular disorders, 2) Clarification and characterization of the genes which cause leukemia and neuroblastoma, 3) Role of hemodynamic factors on pulmonary hypertension complicated with congenital heart diseases, 4) Epidemiological survey and nationwide registry of primary immunodeficiency diseases and the efficacy of immunotherapy for cancer using peripheral dendritic cells, 5) Molecular and functional analysis of the genes for inherited endocrine and metabolic diseases, and 6) Pathogenesis of peroxisome biogenesis disorders. The details of the research projects are described below.

We have been the local registration center for children's cancer in Kantou-district. This helps and promotes the basic research in the fields of Hematology and Oncology in our Pediatrics.

Faculties and Students

Professor and Chair	Takashi Igarashi, M.D., Ph.D. (2000-)
Associate Professors	Tsutomu Iwata, M.D., Ph.D.
Lecturers	Yasuhide Hayashi, M.D., Ph.D. Masaru Takamizawa, M.D., Ph.D. Hitoshi Kato, M.D., Ph.D. Takashi Sekine, M.D., Ph.D. Yoichi Sakakihara, M.D., Ph.D.

Associates	15
Postdoctoral Fellow	4
Graduate student	18
Research student.....	3
Secretary	3

Past Research and Major Accomplishments

Nephrology

- 1) Molecular pathogenesis of Dent's disease, proximal renal tubular acidosis and renal hypouricemia: feedback from bench to clinics.
- 2) The mechanisms of post-diarrheal hemolytic uremic syndrome (HUS).
- 3) Molecular identification of the proximal tubular transporters that excrete drugs from the kidney.

Hematology and Oncology

- 1) Identification of *HOXD11*, *HOXA13* and *HOXC11* genes as partner genes of *NUP98* in t (2;11)-, t (7;11)- and t (11;12)- acute myeloid leukemias.
- 2) Molecular analysis of tumor suppressor genes in neuroblastoma.

Cardiology

- 1) Role of hemodynamic factors on pulmonary hypertension complicated with congenital heart diseases.
- 2) Development of coronary artery from cardiac neural crest cells.
- 3) Effect of epoprostenol on severe port pulmonary hypertension complicated with biliary atresia.
- 4) Historical review of Kawasaki disease: When Kawasaki disease started in Japan?

Immunology and Allergy

- 1) Epidemiological survey and nationwide registry of primary immunodeficiency diseases.
- 2) The efficacy of immunotherapy for cancer using peripheral dendritic cells.
- 3) The effective and safe simultaneous administration of several vaccines in a short period of time before liver transplantation and their administration under immunosuppressive conditions after transplantation.
- 4) Prospective study of atopic status in infants of the cohort in Tokyo, Japan.
- 5) Epidemiology of bronchial asthma among children in rural and urban area in Bangladesh.

Endocrinology and Metabolism

- 1) Molecular and functional analysis of the genes for several inherited endocrine and metabolic diseases including the glutamate dehydrogenase gene in congenital hyperinsulinism hyperammonemia syndrome, glucose-6-phosphatase gene in glycogen storage disease type 1a, CREB-binding protein in Rubinstein-Taybi syndrome, hepatocyte nuclear factor-1b in maturity-onset diabetes of the young type 5.

Neurology

- 1) Pathogenesis of peroxisome biogenesis disorders: Altered lipid metabolism in peroxisome-defective cells.
- 2) The genetic analysis of Japanese patients with spinal muscular atrophy.
- 3) The analysis of pathophysiology of epileptic syndrome and higher brain function in children by magnetoencephalography.
- 4) Development of communication tool for patients with spinal muscular atrophy.

Current Research

Nephrology

- 1) Molecular and functional analysis of various ion transporters such as Cl channels, Na⁺/HCO₃⁻ cotransporter, URAT1, barttin, and H⁺-ATPase.

- 2) Molecular and functional analysis of LMX1B in nail patella syndrome and hepatocyte nuclear factor-1 β in MODY5.
- 3) The mechanisms of post-diarrheal HUS.

Hematology and Oncology

- 1) Identification of *HOXD11*, *HOXA13* and *HOXC11* genes as partner genes of *NUP98* in t (2;11)-, t (7;11)- and t (11;12)- acute myeloid leukemias.
- 2) Molecular analysis of tumor suppressor genes in neuroblastoma.

Cardiology

- 1) Role of hemodynamic factors on pulmonary hypertension complicated with congenital heart diseases.
- 2) Development of coronary artery from cardiac neural crest cells.

Immunology and Allergy

- 1) Epidemiological survey and nationwide registry of primary immunodeficiency diseases.
- 2) The efficacy of immunotherapy for cancer using peripheral dendritic cells.
- 3) Prospective study of atopic status in infants of the cohort in Tokyo, Japan.
Epidemiology of bronchial asthma among children in rural and urban area in Bangladesh.
- 5) Analysis of the function of basophils in allergic diseases.

Endocrinology and Metabolism

- 1) Molecular and functional analysis of the genes for several inherited endocrine and metabolic diseases including the glutamate dehydrogenase gene in congenital hyperinsulinism hyperammonemia syndrome, glucose-6-phosphatase gene in glycogen storage disease type 1a, CREB-binding protein in Rubinstein-Taybi syndrome, hepatocyte nuclear factor-1b in maturity-onset diabetes of the young type 5.

Neurology

- 1) Pathogenesis of peroxisome biogenesis disorders- Altered lipid metabolism in peroxisome-defective cells.
- 2) The analysis of pathophysiology of epileptic syndrome and higher brain function in children by magnetoencephalography.
- 3) Development of communication tool for patients with spinal muscular atrophy.

Future Prospects

Nephrology

- 1) Molecular and functional analysis of various renal transporter disorders.
- 2) Identification of the genes for minimal change nephrotic syndrome.

Hematology and Oncology

- 1) Identification and characterization of *HOXD11*, *HOXA13* and *HOXC11* genes as partner genes of *NUP98* in t (2;11)-, t (7;11)- and t (11;12)- acute myeloid leukemias.
- 2) Molecular analysis of tumor suppressor genes in neuroblastoma.

Cardiology

- 1) Role of hemodynamic factors on pulmonary hypertension complicated with congenital heart diseases.
- 2) Development of coronary artery from cardiac neural crest cells.

Immunology and Allergy

- 1) Epidemiological survey and nationwide registry of primary immunodeficiency diseases.
- 2) The efficacy of immunotherapy for cancer using peripheral dendritic cells.
- 3) Prospective study of atopic status in infants of the cohort in Tokyo, Japan.
- 4) Epidemiology of bronchial asthma among children in rural and urban area in Bangladesh.
- 5) Analysis of the function of basophils in allergic diseases.

Endocrinology and Metabolism

- 1) Mutational and functional analysis of the genes for several inherited endocrine and metabolic diseases.

Neurology

- 1) Pathogenesis of peroxisome biogenesis disorders- Altered lipid metabolism in peroxisome-defective cells.
- 2) The analysis of higher brain function by magnetoencephalography.
- 3) Development of communication tool for patients with spinal muscular atrophy.

Research Grants (5 selections)

- 1) Igarashi T: Early diagnosis, management and treatment of intractable kidney and urinary tract diseases (Kodomokatei-H13-011). Ministry of Health, Labor and Welfare, 16,000,000 yen in 2001-2002.

- 2) Iwata T: The association between Urbanization and Childhood Asthma in Bangladesh. Nissan Science Foundation, 4,500,000 yen in 2000-2001, 3,600,000 yen in 2002-2003.
- 3) Hayashi Y: Analysis of molecular mechanism of cancer formation due to translocation gene by using genome information and expression profile (B-2-14370242). Ministry of Education Science, 8,800,000 yen in 2002-2004.
- 4) Hayashi Y: Gene analysis and diagnosis of intractable childhood leukemia and secondary leukemia and their application to the clinics. Ministry of Health, Labor and Welfare, 7,400,000 yen in 1996-2002.
- 5) Kato H: Role of hemodynamic factors on pulmonary hypertension complicated with congenital heart diseases (No. 09470177). Ministry of Health, Labor and Welfare, 5,300,000 yen in 1999-2001.

Select Publications

Nephrology

1. Sekine T, Cha SH, Hosoyamada M, Kanai Y, Watanabe N, Huruta Y, Hukuda K, Igarashi T, Endou H: Cloning, functional characterization and localization of a rat renal Na⁺-dicarboxylate transporter. *Am J Physiol* 275 (*Renal Physiol*. 44): F298-F305, 1998
2. Igarashi T, Günter W, Sekine T, Inatomi J, Shiraga H, Takahashi S, Suzuki J, Tsuru N, Yanagihara T, Shimazu M, Jentsch TJ, Thakker RV: Functional characterization of renal chloride channel, *CLCN5*, mutations associated with Dent's_{Japan} disease. *Kidney Int* 54:1850-1856, 1998
3. Igarashi T, Inatomi J, Sekine T, Cha SH, Kanai Y, Kunimi M, Tsukamoto K, Satoh H, Shimadzu M, Tozawa F, Mori T, Shiobara M, Seki G, Endou H: Mutations in *SLC4A4* cause permanent isolated proximal renal tubular acidosis with ocular abnormalities. *Nature Genet* 23:264-266, 1999
4. Igarashi T, Inatomi J, Wake A, Takamizawa M, Katayama H, Iwata T: Failure of pre-diarrheal antibiotics to prevent hemolytic uremic syndrome in serologically-proven *Escherichia coli* 0157:H7 gastrointestinal infection. *J Pediatr* 135: 768-769, 1999
5. Igarashi T, Inatomi J, Ohara T, Kuwahara T, Shimadzu M, Thakker RV: Clinical and genetic studies of *CLCN5* mutations in Japanese families with Dent's disease. *Kidney Int* 58: 520-527, 2000
6. Igarashi T, Inatomi J, Sekine T, Seki G, Shimadzu M, Tozawa F, Takeshima Y, Takumi T, Takahashi T, Yoshikawa N, Nakamura H, Endou H: Novel non-sense mutation in the Na⁺/HCO₃⁻ cotransporter gene (*SLC4A4*) in a patient with permanent isolated proximal renal tubular acidosis and bilateral glaucoma. *J Am Soc Nephrol* 12: 713-718, 2001
7. Usui T, Hara M, Satoh H, Moriyama N, Kagaya H, Amano S, Oshika T, Ishii Y, Ibaraki N, Hara C, Kunimi M, Noiri E, Tsukamoto K, Inatomi J,

- Kawakami H, Endou H, Igarashi T, Goto A, Fujita T, Araie M, Seki G: Molecular basis of ocular abnormalities associated with proximal renal tubular acidosis. *J Clin Invest* 108: 107-115, 2001
8. Kuwahara M, Iwai K, Ooeda T, Igarashi T, Ogawa E, Katsushima Y, Shinbo I, Uchida S, Terada Y, Fujiwara TM, Arthus MF, Lonergan M, Bicher DG, Marumo F: Three families with autosomal dominant nephrogenic diabetes insipidus caused by aquaporin-2 mutations in the C-terminus. *Am J Human Genetics* 69: 738-748, 2001
 9. Norden AGW, Lapsley M, Christensen EI, Igarashi T, Matsuyama T, Shiraga H, Kelleher CL, Lee P, Scheinman SJ, Thakker RV, Unwin RJ, Verroust P, Wrong O, Moestrup S: Urinary megalin deficiency implicates abnormal tubular endocytic receptor trafficking in the Fanconi syndrome. *J Am Soc Nephrol* 13: 125-133, 2002
 10. Chandler WL, Jelacic S, Boster D, Ciol M, Watkins S, Igarashi T, Tarr PI: Prothrombotic coagulation abnormalities preceding the hemolytic uremic syndrome. *New Eng J Med* 246: 23-32, 2002
 11. Enomoto A, Kimura H, Chairoungdua A, Shigeta Y, Jutabha P, Cha SH, Hosoyamada M, Takeda M, Sekine T, Igarashi T, Matsuo H, Kikuchi Y, Oda T, Ichida K, Hosoya T, Shimokata K, Niwa T, Kanai Y, Endou H: Molecular identification of a renal/urate/anion exchanger that regulates blood urate levels. *Nature* 417: 447-452, 2002

Hematology and Oncology

12. Futatani T, Miyawaki T, Tsukada S, Hashimoto S, Kunikata T, Arai S, Kurimoto M, Niida Y, Matsuoka H, Sakiyama Y, Iwata T, Tsuchiya S, Tatsuzawa O, Yoshizaki K, Kishimoto T: Deficient expression of Bruton's tyrosine kinase in monocytes from X-linked agammaglobulinemia as evaluated by a flow cytometric analysis and its clinical application to carrier detection. *Blood* 15:595-602, 1998
13. Ishiguro A, Ishikita T, Shimbo T, Matsubara K, Baba K, Hayashi Y, Naritaka S, Nakahata T: Elevation of serum thrombopoietin precedes thrombocytosis in Kawasaki disease. *Thromb Haemost* 79:1096-1100, 1998
14. Kitabayashi I, Ida K, Morohoshi F, Yokoyama A, Mitsuhashi N, Shimizu K, Nomura N, Hayashi Y, Ohki M: The AML1-MTG8 leukemic fusion protein forms a complex with a novel member of the MTG8 (ETO/CDR) family, MTGR1. *Mol Cell Biol* 18:846-858, 1998
15. Miyagawa K, Kent J, Moore A, Charlier JP, Little MH, Williamson KA, Kelsey A, Brown KW, Hassam S, Briner J, Hayashi Y, Hirai H, Yazaki Y, van Heyningen V, Hastie ND: Loss of WT1 function leads to ectopic myogenesis in Wilms' tumour. *Nat Genet* 18:15-17, 1998
16. Taki T, Shibuya N, Taniwaki M, Hanada R, Morishita K, Bessho F, Yanagisawa M, Hayashi Y: ABI-1, a human homolog to mouse Abl-interactor 1, fuses the MLL gene in acute myeloid leukemia with t(10;11)(p11.2;q23). *Blood* 92:1125-1130, 1998
17. Takita J, Hayashi Y, Nakajima T, Adachi J, Tanaka T, Yamaguchi N, Ogawa Y, Hanada R, Yamamoto K, Yokota J: The p16 (CDKN2A) gene is involved in the growth of neuroblastoma cells and its expression is associated with prognosis of neuroblastoma patients. *Oncogene* 17:3137-3143, 1998
18. Yamamoto K, Hanada R, Kikuchi A, Ichikawa M, Aihara T, Oguma E, Moritani T, Shimanuki Y, Tanimura M, Hayashi Y: Spontaneous regression of localized neuroblastoma detected by mass screening. *J Clin Oncol* 16:1265-1269, 1998
19. Bessho F: Incidence of neuroblastoma. *The Lancet* 353: 70, 1999
20. Kawa K, Ohnuma N, Kaneko M, Yamamoto K, Etoh T, Mugishima H, Ohira M, Yokoyama J, Bessho F, Honna T, Yoshizawa J, Nakada K, Iwafuchi M, Nozaki T, Mimaya J, Sawada T, Nakamura T, Miyata H, Yamato K, Tsuchida Y: Long-term survivors of advanced neuroblastoma with MYCN amplification; a report of 19 patients surviving disease-free for more than 66 months. *J Clin Oncol* 17:3216-3220, 1999
21. Taki T, Ohnishi H, Shinohara K, Sako M, Bessho F, Yanagisawa M, Hayashi Y: AF17q25, a putative septin family gene, fuses the MLL gene in acute myeloid leukemia with t(11;17)(q23;q25). *Cancer Res* 59: 4261-4265, 1999
22. Taki T, Kano H, Taniwaki M, Sako M, Yanagisawa M, Hayashi Y: AF5q31, a newly identified AF4-related gene, is fused to MLL in infant acute lymphoblastic leukemia with ins(5;11)(q31;q13q23). *Pro Nat Acad Sci USA* 96: 14535-14540, 1999
23. Hayashi Y, Honma Y, Niitsu N, Taki T, Bessho F, Sako M, Mori T, Yanagisawa M, Tsuji K, Nakahata T: SN-1, a novel leukemic cell line with t(11;16)(q23;p13): Myeloid characteristic and resistance to retinoids and vitamin D3. *Cancer Res* 60:1139-1145, 2000
24. Toyoda Y, Manabe A, Tsuchida M, Hanada R, Ikuta K, Okimoto Y, Ohara A, Ohkawa Y, Mori T, Ishimoto K, Satoh T, Kaneko T, Maeda M, Koike K, Shitara T, Hoshi Y, Hosoya R, Tsunematsu Y, Bessho F, Nakazawa S, Saito T for the Acute Lymphoblastic Leukemia Committee of the Tokyo Children's Cancer Study Group: Six months of maintenance chemotherapy after intensified treatment for acute lymphoblastic leukemia of childhood. *J Clin Onco* 18:1508-1516, 2000
25. Chen YZ, Soeda E, Yang HW, Takita J, Chai L, Horii A, Inazawa J, Ohki M, Hayashi Y: Homozygous deletion in a neuroblastoma cell line defined by a high density STS map spanning human chromosome band 1p36. *Genes Chromosomes & Cancer* 31:326-332, 2001
26. Jamal R, Taketani T, Taki T, Bessho F, Hongo T, Hamaguchi H, Horiike S, Taniwaki M, Hanada R, Nakamura H, Hayashi Y: Co-duplication of the MLL and FLT3 gene in patients with acute myeloid

- leukemia. *Genes Chromosomes & Cancer* 31: 187-190, 2001
27. Niitsu N, Hayashi Y, Honma Y: Downregulation of MLL-CBP fusion gene expression is associated with differentiation of SN-1 cells with t (11;16)(q23;p13). *Oncogene* 20: 375-384, 2001
 28. Shibuya N, Taki T, Mugishima H, Chin M, Tsuchida M, Sako M, Kawa K, Ishii E, Miura I, Yanagisawa M, Hayashi Y: t (10; 11)-acute leukemias with MLL-AF10 and MLL-ABI1 chimeric transcripts; specific expression patterns of ABI1 gene in leukemia and solid tumor cell lines. *Genes Chromosomes & Cancer* 32:1-10, 2001
 29. Takita J, Yang HW, Chen YY, Hanada R, Yamamoto K, Teitz T, Kidd V, Hayashi Y: Allelic imbalance on chromosome 2q and alterations of the caspase 8 gene in neuroblastoma. *Oncogene* 19:4424-4432, 2001
 30. Tatsumi K, Taki T, Taniwaki M, Nakamura H, Taguchi J, Chen YZ, Bessho F, Yanagisawa M, Hayashi Y: The CDCREL1 gene fused to MLL in de novo acute myeloid leukemia with t (11;22)(q23;q11.2) and its frequent expression in myeloid leukemia cell lines. *Genes Chromosomes & Cancer* 30:230-235, 2001
 31. Yang HW, Chen YZ, Takita J, Soeda E, Piao HY, Hayashi Y: Genomic structure and mutational analysis of the human KIF1B gene which is homozygously deleted in neuroblastoma at chromosome 1p36.2. *Oncogene* 16:5075-5083, 2001
 32. Zhao C, Takita J, Tanaka Y, Setou M, Nakagawa T, Takeda S, Yang HW, Terada S, Nakata T, Takei Y, Saito M, Tsuji S, Hayashi Y, Hirokawa N: Charcot-Marie-Tooth disease type 2A caused by mutation in a microtubule motor KIF1B β . *Cell* 105:587-597, 2001
 33. Ono R, Taki T, Taketani T, Kawaguchi H, Taniwaki M, Okamura T, Kawa K, Hanada R, Kobayashi M, Hayashi Y: SEPTIN6, a human homologue to mouse Septin6, is fused to MLL in infant acute myeloid leukemia with complex chromosomal abnormalities involving 11q23 and Xq24. *Cancer Res* 62:333-337, 2002
 34. Ono R, Taki T, Taketani T, Taniwaki M, Kobayashi H, Hayashi Y: LCX, leukemia-associated protein with a CXXC domain, is fused to MLL in acute myeloid leukemia with trilineage dysplasia having t (10;11)(q22;q23). *Cancer Res* 62:4075-80, 2002
 35. Taketani T, Taki T, Shibuya N, Ito E, Kitazawa J, Terui K, Hayashi Y: The HOXD11 gene is fused to the NUP98 gene in acute myeloid leukemia with the t (2;11)(q31;p15). *Cancer Res* 62:33-37, 2002
 36. Taketani T, Taki T, Ono R, Kobayashi Y, Ida K, Hayashi Y: The t (7;11)(p15;p15) in acute myeloid leukemia results in fusion of the NUP98 gene with a HOXA cluster gene, HOXA13, but not HOXA9. *Genes Chromosomes & Cancer* 34:437-443, 2002
 37. Uno K, Takita J, Yokomori K, Tanaka Y, Ohta S, Shimada H, Gilles FH, Sugita K, Abe S, Sako M, Hashizume K, Hayashi Y: Aberrations of the hSNF5/INI1 gene are Restricted to malignant rhabdoid tumors or atypical teratoid/rhabdoid tumors in pediatric solid tumors. *Genes Chromosomes & Cancer* 34:33-41, 2002
- Cardiology**
38. Shibuya K, Bigras JL, McCrindle BW, Newman A, Smallhorn JF: Normal values in children for myocardial ultrasonic tissue characterization by integrated backscatter. *Echocardiography* 15:353-361, 1998
 39. Ishiguro A, Ishikita T, Shimbo T, Matsubara K, Baba K, Hayashi Y, Naritaka S, Nakahata T: Elevation of serum thrombopoietin precedes thrombocytosis in Kawasaki disease. *Thromb Haemo* 79:1096-1100, 1998
 40. Shibuya N, Shibuya K, Kato H, Yanagisawa M: Kawasaki disease before Kawasaki at Tokyo University Hospital. *Pediatrics* 110: e17, 2002
- Immunology and Allergy**
41. Takamizawa M, Rivas A, Fagnoi F, Benike C, Kosek J, Hayakawa H, Engleman EG: Dendritic cells that process and present nominal antigens to naïve T lymphocytes are derived from CD2⁺ precursors. *J Immunol* 158: 2134-2142, 1997
 42. Cui SH, Tanabe F, Terunuma H, Iwatani Y, Nunoi H, Agematsu K, Komiyama A, Nomura A, Hara T, Onodera T, Iwata T, Ito M: A thiol proteinase inhibitor, E-64-d, corrects the abnormalities in concanavalin-A cap formation and the lysosomal enzyme activity in leucocytes from patients with Chediak-Higashi syndrome by reversing the down-regulated protein kinase C activity. *Clin Exp Immunol* 125:283-290, 2001
 43. Yoshimura C, Yamaguchi M, Iikura M, Izumi S, Kudo K, Nagase H, Ishii A, Walls AF, Ra C, Iwata T, Igarashi T, Yamamoto K, and Hirai K: Activation markers of human basophils: CD69 expression is strongly and preferentially induced by IL-3. *J Allergy Clin Immunol* 109: 817-823, 2002
- Endocrinology and Metabolism**
44. Goto M, Taki T, Sugie H, Miki Y, Kato H, Hayashi Y: A novel mutation in the glucose-6-phosphatase gene in Korean twins with glycogen storage disease type 1a. *J Inherit Metab Dis* 23:851-852, 2000
 45. Miki Y, Taki T, Ohura T, Kato H, Yanagisawa M, Hayashi Y: Novel missense mutations in the glutamate dehydrogenase gene in the congenital hyperinsulinism hyperammonemia syndrome. *J Pediatr* 136:69-72, 2000
- Neurology**
46. Kobayashi K, Nakahori Y, Miyake M, Matsunuma K, Kondo-Iida, E, Nomura Y, Segawa M, Yoshioka M, Saito K, Osawa M, Hamano K, Sakakihara Y, Nonaka I, Nakagome Y, Kanazawa I, Nakamura Y, Tokunaga K, Toda T: An ancient retrotransposal insertion causes Fukuyama-type congenital muscular dystrophy. *Nature* 394:388-392, 1998

47. Kubota M, Takeshita K, Sakakihara Y, Yanagisawa M: Magnetoencephalographic study of giant somatosensory evoked responses in patients with rolandic epilepsy. *J Child Neurol* 15: 370-379, 2000
48. Kurachi Y, Oka A, Itoh M, Mizuguchi M, Hayashi M, Takashima S: Distribution and development of CLN2 protein, the late-infantile neuronal ceroid lipofuscinosis gene product. *Acta Neuropathol* 102:20-26, 2001
49. Tatsumi K, Saito M, Lin B, Iwamori M, Ichiseki H, Shimozawa N, Kamoshita S, Igarashi T, Sakakihara Y: Enhanced expression of a-series gangliosides in fibroblasts of patients with peroxisome biogenesis disorders. *Biochim Biophys Acta* 1535:285-293, 2001
50. Saito M, Fukushima Y, Tatsumi K, Bei L, Fujiki Y, Iwamori M, Igarashi T: Molecular cloning of Chinese hamster ceramide glucosyltransferase and its enhanced expression in peroxisome-defective mutant Z65 cells. *Arch Biochem Biophys* 403:171-178, 2002

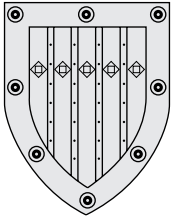

Department of Pediatric Surgery / Department of Pediatric Oncology

Outline and Research Objectives

The history of Department of Pediatric Surgery is not long in University of Tokyo. It first started as a clinical department of University of Tokyo Hospital in 1971. In 1989 it became a department in The Faculty of Medicine and then transferred to The Graduate School of Medicine as a part of the change of the system. So the duration of research in our department is not long. Also we have only few staff in our department. However, we have continued research very intensively by collaboration with other departments in The Graduate School of Medicine, University of Tokyo, and other institutes in Japan and abroad.

Our main themes of research are in three areas, namely transplantation medicine, developmental biology of congenital anomalies and fetal surgery, and immunology of intestine.

Department of Pediatric Oncology was separated from Department of Pediatric Surgery when the system changed, and Graduate School of Medicine became the major. Before that, studies concerning pediatric oncology was done in the Department of Pediatric Surgery and also in the Department of Pediatrics. Now as a system, Department of Pediatrics is separated from the Department of Pediatric Oncology, the group of pediatric oncology in the Department of Pediatrics actually works with the Department of Pediatric Oncology, and constitutes a part of the department.

Pediatric malignancies are very special and consist only a very small part of all the malignancies considering the number of patients. However, because of their peculiarities, they have some privileges and advantages. For example, about the theory of oncogenesis, famous "two-hit theory" by Knudson was first proposed for pediatric malignancies, retinoblastoma and neuroblastoma. It is because that the mechanism of oncogenesis in these tumors is very simple compared to that of adult malignancies. Also the "multi-disciplinary treatment" of malignant diseases first successfully introduced to malignant solid tumors in infancy and children. So the study of pediatric oncology is very important and it has possibility of break-through in the study of oncology general. Now we mainly study oncogenes related to pediatric malignancies especially neuroblastoma, and immuno-therapy of cancer using dendritic cells.

Faculties and Students

Professor and Chair	Kohei Hashizume, M.D.,Ph.D. (since 1997)
Lecturer	Yutaka Kanamori, M.D.,Ph.D.. (Yasuhide Hayashi, M.D.,Ph.D.)
Associates	3
Graduate Students	4
Secretary	2

Past Research and Major Accomplishments

In the area of transplantation medicine, we started clinical living-related liver transplantation with the Department of Artificial Organ and Transplantation and have operated about 100 pediatric cases. Associate Professor Kawarasaki in our department who was in charge in liver transplantation moved to Jichi Medical School in 2001. So we stopped clinical

liver transplantation in pediatric cases. But we continue research in this area now. We studied immunological tolerance using rat heart transplantation model, and found that donor specific transfusion induce immunological tolerance. Then we analyzed rat serum after donor specific transfusion using liquid chromatography. We found three kinds of proteins that have a function of immunosuppression. Especially one of those 3 protein, MAY-1 is a completely new protein with 234 amino acid and has a possibility of usage as a immunosuppression drug in clinical transplantation.

We studied small bowel transplantation using a model of small bowel transplantation with a free graft of newborn intestine into the recipient's omentum. In this model we showed good neovascularization and histologically mature intestine after the transplantation. We also showed the near normal motility and absorption in this transplanted intestine. In short-boweled rats, transplantation of newborn intestine

could restore the weight loss and could save the lives of these short-boweled rats. Also cryopreserved newborn intestine could function as good as fresh intestine after transplantation.

We also studied warm ischemia-reperfusion injury of the liver in rat model. We showed that pretreatment of the liver with cyclosporine reduce damage to the liver, but pretreatment with FTY720 rather prolong damage to the liver. So pretreatment with immuno-suppressive drugs of the liver does not universally beneficial for the prevention of warm ischemia-reperfusion injury.

In the area of developmental biology of congenital anomalies and fetal surgery, we very intensively studied congenital diaphragmatic hernia (CDH) using rat model induced by a drug nitrofen. CDH is one of the most difficult to treat congenital anomalies with high mortality. Until recently its experimental study was done using only sheep model that is made by fetal surgery. The problem is that the fetal surgery can be done only in late phase of pregnancy, many features of this model is quite different from that of human CDH. We noticed rat CDH induced by administration of nitrofen to pregnant rat. The CDH by this method develop at very early stage of fetal development and very similar to human CDH. First we showed clearly that hypoplasia of the lungs develop by CDH, and spreading of surfactant phospholipids in the alveolar cells to the lumen of alveoli is strongly impaired in fetuses with CDH. Then we studied the effects of fetal surgery to lung hypoplasia in CDH. We developed experimental model of tracheal ligation in rat CDH model. Using this model, we showed that tracheal ligation can overcome the hypoplasia of the lungs induced by CDH. By ligation of the trachea the lungs grow very rapidly, and the weight, contents of protein and DNA of the lungs, and histological structure normalize. By this experiment we clearly showed that tracheal ligation can overcome the hypoplasia of the lungs in CDH, and that this simple fetal surgery can same the lives of babies with CDH and severe hypoplasia of the lungs whom it is very difficult to treat after birth.

We also developed another new model of congenital anomaly in a species of amphibian, *Cynopus pyrrhogaster*. We succeeded to produce split cord malformation in *Cynopus* embryos experimentally incising a part of neural plate and notochord. With this procedure, fistulae developed between endoderm and ectoderm, and in some cases endodermal or neural cysts developed. This experiment shed light to the cause of split notochord syndrome and also duplication of intestine.

In the area of immunology of intestine, Kanamori first described novel lymphoid tissues, cryptopatch in murine intestinal mucosa in 1996. Then we studied human intestinal mucosa for the existence of lymphoid tissues corresponding to the cryptopatch in

mouse. We could not show the existence of such lymphoid tissues in human. So we turned to study the functions of already known lymphoid tissues in human if they have functions corresponding to cryptopatch in mouse and compensate the absence of that. Using surgical specimens of jejunum of infants, we looked for lymphoid tissues in the mucosa of the jejunum, and examined the distribution of these tissues. We found Peyer's patches and isolated lymphoid follicles. Peyer's patches distributed in antimesenteric area, but isolated lymphoid follicles distributed irregularly all through the surface of the mucosa, and in these isolated lymphoid follicles CD19 positive and CD3 positive lymphoid cells are distributed.

We introduced new synbiotics therapy to various intestinal conditions in children, namely short bowel syndrome, inflammatory bowel diseases, and pseudo-Hirschsprung disease. We administered two types of probiotics (*Bifidobacterium brevis* and *Lactobacillus casei*) together with prebiotic (galactooligosaccharides) to these patients. After the introduction of this therapy, the patients' clinical conditions dramatically improved. Feces became more solid and less foul-smelling, the patients got weight, abnormal dilatation of the intestine improved, and frequency of bacterial translocation decreased. We also showed change of bacterial flora of feces. Those two types of probiotics became the main flora, and the number of pathogenic bacteria dramatically decreased.

In the area of pediatric oncology, we started our study of pediatric oncology in the field of histochemistry. We studied expression of multi-drug resistance related protein, P-glycoprotein in neuroblastoma cells. Surprisingly, it was shown that high expression of P-glycoprotein was related to better prognosis of patients. It looks paradoxical, but we also found in normal adrenal medulla cells, P-glycoprotein is expressed. So high expression of P-glycoprotein in neuroblastoma means rather well-differentiation of these tumors, and consequently better prognosis. Our result was confirmed later by other publications.

Recently we are concentrated in the study of oncogene in pediatric malignancies, especially neuroblastoma and Wilms tumor. It is well known that neuroblastomas whose cells show chromosome 1p deletion have poor prognosis. We intensively looked for probable oncogene in this region, but it has not yet discovered. There was one great side product of this project. In this region we found kinesin superfamily motor protein KIF1B, and it was shown loss-of-function mutation in the motor domain of the KIF1B gene causes Charcot-Marie-Tooth disease type 2A. We studied expression, LOH, and mutation of p73 gene that is mapped to 1p36. We found aberrant expression of p73 is significantly higher in advanced-stages neuroblastoma, but no homozygous deletion of p73 was

found in any of the sample. So we conclude p73 is less involved in the development but involved in the progression of neuroblastoma. We also studied other genes mapped in other chromosomes because other chromosome anomalies other than 1p deletion are related to prognosis of neuroblastoma. For example, 17q gain is known to relate to poor prognosis. We studied survivin mapped to 17q25, which is a member of inhibitor of apoptosis proteins (IAPs). We found high expression of survivin is a strong prognostic indicator for the advanced stage neuroblastomas, and there is a possibility that it is one of the candidate genes for the 17q gain.

In the study of Wilms tumor, we found a novel WT1 gene mutation in a patient with Wilms tumor, male hermaphroditism, but without renal disease. The mutation was at intron 7 in tumor cells and also germ line cells. This mutation is thought to produce truncated WT1 protein, and it is related to the genitourinary anomalies and genesis of Wilms tumor in this patients. Also the clinical course of this patient was rather atypical for Wilms tumor in general, and we think this peculiar mutation should influence the course of the disease.

Other than neuroblastoma and Wilms tumor, we studied hepatoblastoma. We examined mutation of beta-catenin in the tumors of 68 cases of hepatoblastoma. We found mutation of beta-catenin in 44 (65%) tumors. In these 44, 9 was point mutation, 35 was deletion mutation. We also studied the expression of beta-catenin by histochemistry. We found beta-catenin is accumulated in the nuclei of tumor cells, and in these cases with beta-catenin accumulation, cyclin D1 was also accumulated in the nuclei. We conclude that in hepatoblastoma because of frequent mutation of beta-catenin gene, beta-catenin protein accumulates in the nuclei and cause activation of cyclin D1, that results growth or progression of the tumor. We also found beta-catenin accumulation in the nuclei of two cases of hepatic adenoma. In one of these 2 cases, mutation of beta-catenin gene was found. This is the first report of beta-catenin mutation in the case of hepatic adenoma, and we think it shed light to the genesis of hepatic adenoma and its relation to hepatoblastoma.

Current Research

In the area of transplantation medicine, our main themes are prevention of ischemia-reperfusion injury in liver transplantation, and development of safer method in transplantation of small bowel. In the former theme, we developed partial liver transplantation model in rat, and studying the effect of gene introduction to the graft. In the preliminary study, we got promising effect of gene introduction. In transplan-

tation of small intestine, we have succeeded in the transplantation of cryopreserved newborn intestine, but found cryopreservation had no effect on antigenicity of the graft. So we are studying methods to reduce the antigenicity of the intestinal graft to improve the survival of intestinal transplantation.

In the area of developmental biology of congenital anomalies and fetal surgery, we are doing experimental fetal surgery of tracheal obstruction using lambs. We developed new laryngoscope specially designed for the obstruction of trachea of fetal lambs using balloon. We have successfully introduced balloon into fetal trachea, and have shown growth of the lungs after the introduction of balloon.

In the area of immunology of intestine, we are studying the cells found in isolated lymphoid follicles in the mucosa of infants, their characters, development, and migration. We are considering of using probiotics in wider varieties of diseases, for example patients in PICU who receive rather intensive antibiotics therapy and are prone to develop bacterial translocation and sepsis.

In Pediatric Oncology Department, we continue the search of tumor suppressor gene of neuroblastoma suspected to reside in chromosome 1p. We have established cell line of Wilms tumor with WT1 mutation. This cell line has morphological features of stromal cell and epithelial cell. Using this cell line, we are considering to do a study concerning the factors that determine the differentiation of the tumor. Wilms tumor shows a very wide variety of histology. In some tumors, histology is almost universally epithelial, but in other tumors, they show stroma-dominant histology with only small part of epithelium. Because the histological type relate to the prognosis of the tumor, we can know the factors related to prognosis, if we can find out factors that determine the histological features of the tumor.

Concerning the therapy of malignant tumors in children, we are doing a research of immunotherapy using dendritic cells. Immunotherapy using dendritic cells is not studied fully in malignant tumors in children. However, it is well known that neuroblastoma cells show strong tumor-specific antigen, and spontaneous regression of neuroblastoma is well documented. So we think immunotherapy of neuroblastoma is promising. We found using OK-432, dendritic cells can be activated, and CTL can be induced. We want to test this method using target of neuroblastoma cells.

Compared to neuroblastoma and Wilms tumor, genetic and molecular study of hepatoblastoma is retarded. It is necessary to examine genes related to genesis and progression of hepatoblastoma. To examine many kind of genes, gene chip is very effective method, and we are collaborating with Research Center for Advanced Science and Technology of University of Tokyo. Using this method and compar-

ing gene expression profiles of hepatoblastoma, normal liver, and cirrhotic liver, we have found some genes that specifically expressed in hepatoblastoma.

Future Prospects

One very important aspect of study in our department is establishment of new area of medicine "fetology". To know and to treat patients with various congenital anomalies, it is mandatory to know fetal development of normal baby and babies with congenital anomalies. Development of imaging methods in these ten years is enormous. However, we need not only information of structures of fetuses, but also functions of various organs during fetal life. With the development of new technology which will make it possible, we can know the physiology of fetus and the effects of fetal conditions to the health after birth in children and adults.

In this 20 years, prognosis of pediatric malignancies in general has improved dramatically. However there are small fraction of patients whose tumors are very resistant to standard treatment, and are apt to recur after a short period of remission. These tumors probably has some genetic characteristics, and if we can find out some of these characteristics, we can improve the method of therapy and also can improve the prognosis of these patients.

Select Publications

1. Yoshida Y, Kobayashi E, Nozawa M, Uchida H, Fujimura A, Yamanaka T, Miyata M, Hepatic lymphocyte transplantation in hyperbilirubinemic guinea pigs. *Eur Surg Res* 32 (4) : 223-227, 2000
2. Kitano Y, Ruchelli E, Weiner S, Adzick N S. Hepatic Mesenchymal Hamartoma associated with mesenchymal stem villous hyperplasia of the placenta. *Fetal Diagn Therap* 15 : 134-138, 2000
3. Oida T, Suzuki K, Nanno M, Kanamori Y, Saito H, Kubota E, Kato S, Itoh M, Kaminogawa S, Ishikawa H. Role of gut cryptopatches in early extrathymic maturation of intestinal intraepithelial T cells. *J Immunol* 164 : 3616-3626, 2000
4. Kitano Y, Flake AW, Quinn T M, Kanai M, Davies P, Sablich T J, Schneider C, Adzick N S, von Allmen DLung growth induced by tracheal occlusion in the sheep is augmented by airway pressurization. *J Pediatr Surg* 35 : 216-222, 2000
5. Komuro H, Makino S, Tahara K. Choledochal cyst associated with duodenal obstruction. *J Pediatr Surg* 35(8) : 1259-62, 2000
6. Milner R, Kitano Y, Olutoye O, Flake A W, Adzick N S. Radiofrequency thermal ablation (RTA): a potential treatment for hydropic fetuses with a large chest mass. *J Pediatr Surg* 35 : 386-389, 2000
7. A K, Kitano Y, Kriss A, Hensley H, Bergery P, Flake A, Hubbard A, Leigh Jr J S. In vivo, in utero microscopic magnetic resonance imaging: application in a rat model of diaphragmatic hernia. *Magn Reson Med* 44 : 331-335, 2000
8. Islam A, Kageyama H, Hashizume K, Kaneko Y, Nakagawara A. Role of Survivin, whose gene is mapped to 17q25, in human and identification of a novel dominant-negative isoform, Survivin $\beta/2B$. *Med Pediatr Oncol* 35 : 550-553, 2000
9. Kanamori Y, Suzuki K, Oida T, Ishikawa H. Gut-associated lymphoid tissue "Cryptopatches" and intraintestinal development of murine T cells. *Mucosal Immunology Update* 3-5, 2000
10. Islam A, Kageyama H, Takada N, Kawamoto T, Takayasu H, Isogai E, Ohira M, Hashizume K, Kaneko Y, Nakagawara A. High expression of Survivin, mapped to 17q25, is significantly associated with poor prognostic factors and promotes cell survival in human neuroblastoma. *Oncogene* 19 : 617-623, 2000
11. Ohira M, Kageyama H, Mihara M, Furuda S, Machida Y, Takayasu H, Islam A, Nakamura Y, Takahashi M, Shishikra T, Kaneko Y, Toyota A, Sattori S, Sakaki Y, Ohki M, Horri A, Hayashi Y, Soeda E, Inazawa J, Seki N, Kuma H, Nozawa I, Nakagawara A. Identification and characterization of a 500-kb homozygously deleted region at chromosome 1p36.2 in a human neuroblastoma cell line. *Oncogene* 19 : 4302-4307, 2000
12. Emura T, Asashima M, Hashizume K. An Experimental Animal Model of Split Cord Malformation. *Pediatr Neurosurg* 33:283-292, 2000
13. Komuro H, Makino S, Tahara K. Laparoscopic resection of an adrenal neuroblastoma detected by mass screening that grew in size during the observation period. *Surg Endosc* 14(3) : 297, 2000
14. Kawarasaki H, Hashizume K, Makuuchi M. Live Related Pediatric Liver Transplantation. In DK Gupta (Ed.). *Textbook of Neonatal Surgery*, New Delhi, Modern Publishers, 202-206, 2000
15. Uchida H, Tanaka H, Kitoh Y, Yanagisawa K, To H, Tago K, Mizuta K, Fujimura A, Tominaga S, Hashizume K, Kobayashi E. Mechanisms of immunomodulation induced by bloodtransfusion: identification of humoral factors. *Transplant Proc* 32 (2) : 255-256, 2000
16. Ohmori M, Miyashita F, Uchida H, Kitoh Y, Tsuruoka S, Harada K, Sugimoto K, Fujimura A, Kobayashi E. Effect of erythromycin on ischemia-reperfusion injury of liver in rats. *Transplant Proc* 32 (4) : 811-814, 2000
17. Harihara Y, Makuuchi M, Kawasaki S, Hashikura Y, Kawarasaki H, Takayama T, Kubota K, Ito M, Mizuta K, Yoshino H, Hirata M, Kita Y, Sano K, Hisatomi S, Kusaka K, Hashizume K. Influence of HLA compatibility on living-related liver transplantation. *Transplant Proc* 32 : 2107, 2000
18. Harihara Y, Makuuchi M, Kawarasaki H, Takayama T, Kubota K, Ito M, Mizuta K, Yoshino H, Hirata M, Kita Y, Sano K, Hisatomi S, Kusaka K, Miura Y, Taniai N, Asato H, Nakatsuka T, Hashizume K. Living-related liver transplantation in adults compared with children. *Transplant Proc* 32 : 2160-2161, 2000

19. Harihara Y, Sano K, Makuuchi M, Kawarasaki H, Takayama T, Kubota K, Ito M, Mizuta K, Yoshino H, Hirata M, Kita Y, Hisatomi S, K, Miura Y, Hashizume K. Influence of donor age on the graft function after living-related liver transplantation. *Transplant Proc* 32 : 2164-2165, 2000
20. Harihara Y, Sano K, Makuuchi M, Kawarasaki H, Takayama T, Kubota K, Ito M, Mizuta K, Yoshino H, Hirata M, Kita Y, Hisatomi S, Kusaka K, Miura Y, Hashizume K. Correlation between graft size and necessary tacrolimus dose after living-related liver transplantation. *Transplant Proc* 32 : 2166-2167, 2000
21. Hirata M, Harihara Y, Kita Y, Hisatomi S, Miura Y, Yoshino H, Mizuta K, Ito M, Sano K, Kusaka K, Kawarasaki H, Kubota K, Takayama T, Hashizume K, Makuuchi M. Impact of HLA matching in living-related liver transplantation. *Transplant Proc* 32 : 2108-2109, 2000
22. Hirata M, Harihara Y, Hisatomi S, Miura Y, Yoshino H, Mizuta K, Ito M, Sano K, Taniyai N, Kusaka K, Kita Y, Kawarasaki H, Kubota K, Takayama T, Hashizume K, Makuuchi M. Living-related liver transplantation for patients with primary biliary cirrhosis. *Transplant Proc* 32 : 2208-2209, 2000
23. Hirata M, Harihara Y, Hisatomi S, Miura Y, Yoshino H, Mizuta K, Ito M, Sano K, Taniyai N, Kusaka K, Kita Y, Kawarasaki H, Kubota K, Takayama T, Makuuchi M. A case of esophageal variceal rupture following acute portal vein thrombosis three days after living-related liver transplantation. *Transplant Proc* 32 : 2266-2268, 2000
24. Tahara K, Uchida H, Yasunaru S, Hakamata Y, Kobayashi E. Chimeric patterns after organ transplants using green fluorescent protein-transgenic rat. *American J transplant* 1: 336, 2001
25. Kawase E, Tanaka K, Honna T, Azuma N. A case of atypical WAGR syndrome with anterior segment anomaly and microphthalmos. *Arch Ophthalmol* 119: 1855-1856, 2001
26. Utsuki T, Hashizume K, Iwamori M. Impaired spreading of surfactant phospholipids in the lungs of newborn rats with pulmonary hypoplasia as a model of congenital diaphragmatic hernia induced by nitrofen
27. Hakamata Y, Tahara K, Uchida H, Sakuma Y, Nakamura M, Kume A, Murakami T, Takahashi M, Takahashi R, Hirabayashi M, Ueda M, Miyoshi I, Kasai N, Kobayashi E. Green fluorescent protein-transgenic rat: a tool for organ transplantation research. *Biochem Biophys Res Commun* 286 (4) : 779-85, 2001
28. Takayasu H, Horie H, Hiyama E, Matsunaga T, Hayashi Y, Watanabe Y, Suita S, Kaneko M, Sasaki F, Hashizume K, Ozaki T, Furuuchi K, Tada M, Ohnuma N, Nakagawara A. Frequent deletions and mutations of the beta-catenin gene are associated with overexpression of cyclin D1 and fibronectin and poorly differentiated histology in childhood hepatoblastoma. *Clin Cancer Res* 7(4): 901-8, 2001
29. Kanamori Y, Hashizume K, Sugiyama M, Morotomi M, Yuki N. Combination therapy with *Bifidobacterium breve*, *Lactobacillus casei*, and galactooligosaccharides dramatically improved the intestinal function in a girl with short bowel syndrome. A novel synbiotics therapy for intestinal failure. *Dig Dis Sci* 46: 2010-2016, 2001
30. Sugawara Y, Makuuchi M, Takayama T, Mizuta K, Kawarasaki H, Imamura H, Hashizume K. Liver transplantation using a right lateral sector graft from a living donor to her granddaughter. *Hepatogastroenterology* 48: 261-63, 2001
31. Sugawara Y, Makuuchi M, Takayama T, Imamura H, Dowaki S, Mizuta K, Kawarasaki H, Hashizume K. Small-for-size grafts in living-related liver transplantation. *J Am Coll Surg* 192: 510-13, 2001
32. Tahara K, Uchida H, Kawarasaki H, Hashizume K, Kobayashi E. Experimental small bowel transplantation using newborn intestine in rats: III. Long-term cryopreservation of rat newborn intestine. *J Pediatr Surg* 36 (4) : 602-4, 2001
33. Uchida H, Tahara K, Takizawa T, Inose K, Yashiro T, Hashizume K, Ikeda H, Takahashi M, Kobayashi E. Experimental small bowel transplantation using newborn intestine in rats: IV. Effect of cold preservation on graft neovascularization. *J Pediatr Surg* 36 (12) : 1805-10, 2001
34. Sugawara Y, Mizuta K, Kawarasaki H, Takayama T, Imamura H, Makuuchi M. Risk factors for acute rejection in pediatric living related liver transplantation: The impact of HLA matching. *Liver Transpl* 7: 769-73, 2001
35. Sugawara Y, Makuuchi M, Takayama T, Yoshino H, Mizuta K, Kawarasaki H. Liver transplantation from situs inversus to situs inversus. *Liver Transpl* 7: 829-30, 2001
36. Mizuta K, Kita Y, Harihara Y, Takayama T, Kubota K, Hirata M, Inoue K, Sugawara Y, Sakamoto Y, Ito M, Tanaka H, Inoue Y, Oka T, Kawarasaki H, Hashizume K, Kawasaki S, Makuuchi M. Colectomy for uncontrolled hemorrhagic cecal ulcers due to primary cytomegalovirus infection in living-related liver transplantation. *Medicine of the Americas* 2: 135-138, 2001
37. Nakao A, Ogino Y, Tahara K, Uchida H, Kobayashi E. Orthotopic intestinal transplantation using the cuff method in rats: a histopathological evaluation of the anastomosis. *Microsurgery*. 21 (1) : 12-5, 2001
38. Sakamoto J, Takata A, Fukuzawa R, Kikuchi H, Sugiyama M, Kanamori Y, Hashizume K, Hata J. A Novel WT1 Gene Mutation Associated with Wilms' Tumor and Congenital Male Genitourinary Malformation. *Pediatric Research* 50 : 337-344, 2001
39. Komuro H, Makino S, Momoya T, Uehara Y, Tahara K, Momoi M: Cholangitis associated with cystic dilatation of the intrahepatic bile ducts after antireflux valve construction in biliary atresia. *Pediatr Surg Int* 17 (2-3) : 108-10, 2001
40. Hirata M, Harihara Y, Kitamura T, Hisatomi S, Kato M, Dowaki S, Mizuta K, Sugawara Y, Kita Y, Kubota K, Takayama T, Kawarasaki H, Hashizume K, Makuuchi M: The influence of donor age to graft vol-

- ume increase rate in living donor Liver transplantation. *Transplant Proc* 33: 1416-17, 2001
41. Kanamori Y, Hashizume K, Kawarasaki H, Kitano Y, Sugiyama M, Tanaka Y: Single vaginal ectopic ureter and renal hypoplasia associated with urogenital sinus and abdominal muscular hypoplasia-a novel subtype of prune-belly syndrome in a female child? *Urology* 57: 975vi-ix, 2001
 42. Komuro H, Makino S, Yasuda Y, Ishibashi T, Tahara K, Nagai H. Pancreatic complications in choledochal cyst and their surgical outcomes. *World J Surg* 25 (12) : 1519-23, 2001
 43. Tatsumi K, Taki T, Taniwaki M, Nakamura H, Taguchi J, Chen YZ, Bessho F, Yanagisawa M, Hayashi Y: The CDCREL1 gene fused to MLL in de novo acute myeloid leukemia with t(11;22)(q23;q11.2) and its frequent expression in myeloid leukemia cell lines. *Genes Chromosomes Cancer* 30:230-235, 2001
 44. Murata T, Kurokawa R, Kronen A, Tatsumi K, Ishii M, Taki T, Masuno M, Ohashi H, Yanagisawa M, Rosenfeld MG, Glass CK, Hayashi Y: Defect of histone acetyltransferase activity of the nuclear transcriptional coactivator CBP may cause Rubinstein-Taybi syndrome. *Hum Mol Genet* 10: 1071-1076, 2001
 45. Jamal R, Taketani T, Taki T, Bessho F, Hongo T, Hamaguchi H, Horiike S, Taniwaki M, Hanada R, Nakamura H, Hayashi Y: Co-duplication of the MLL and FLT3 gene in patients with acute myeloid leukemia. *Genes Chromosomes Cancer* 31: 187-190, 2001
 46. Niitsu N, Hayashi Y, Sugita K, Honma Y: Sensitization by 5-aza-2'-deoxycytidine of leukaemia cells with MLL abnormalities to induction of differentiation by all-trans retinoic acid and 1 α , 25-dihydroxyvitamin D $_3$. *Br J Haematol* 112:315-326, 2001
 47. Niitsu N, Hayashi Y, Honma Y: Downregulation of MLL-CBP fusion gene expression is associated with differentiation of SN-1 cells with t(11;16)(q23;p13). *Oncogene* 20: 375-384, 2001
 48. Ohnishi H, Hayashi Y, Okamura T, Tabuchi K, Kobayashi M, Bessho F: An infant with t(4;11)(q21;q23) acute lymphoblastic leukemia successfully treated using immunomagnetically purged autologous bone marrow transplantation. *Med Pediatr Oncol* 36: 388-389, 2001
 49. Shibuya N, Taki T, Mugishima H, Chin M, Tsuchida M, Sako M, Kawa K, Ishii E, Miura I, Yanagisawa M, Hayashi Y: t(10;11)-acute leukemias with MLL-AF10 and MLL-ABI1 chimeric transcripts; specific expression patterns of ABI1 gene in leukemia and solid tumor cell lines. *Genes Chromosomes Cancer* 32:1-10, 2001.
 50. Liu M, Taketani T, Li R, Takita J, Taki T, Yang HW, Kawaguchi H, Ida K, Matsuo Y, Hayashi Y: Loss of p73 gene expression in lymphoid leukemia cell lines is associated with hypermethylation. *Leuk Res* 25:441-447, 2001

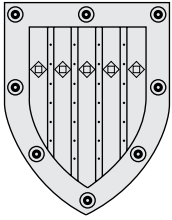

Department of Geriatric Medicine / Department of Aging Research

Outline and Research Objectives

The Department of Geriatrics was established in 1962, as the first geriatric department in Japan.

Since elderly patients usually have multiple organ disorders, we have to take care of the patients as whole from multiple points of view. In addition, in the elderly patients, symptoms and signs, responses to the treatment are sometimes quite different from the young. We have to have a broad knowledge on the physiological and metabolic changes with aging when we treat the elderly patients. Quality of life of the patients is another point of view which should be emphasized.

Our sub-specialty includes respiratory, cardiology, neurology, hematology, bone metabolism, besides the general geriatric internal medicine. We are trying to elucidate the pathophysiology of aging process and elderly patients from viewpoints of basic aging science using molecular biology technique and clinical aspects using the recent advancement of technology and geriatric assessment.

There are 19 plus additional beds about 6 in the clinical ward, which are under the supervision of the residents and assistant staff members. An assistant staff member with more than 10 years experience teams up with the resident on a man-to-man basis, giving instruction as to actual clinical decision making and procedures. The final decision making is performed during the weekly Professor's rounds.

We have also developed new geriatric scale such as vitality index. This is a unique index for assessment of energy and vitality in frail elderly patients. Comprehensive geriatric assessment and critical path applied for the treatment and care of the patients. Based on these comprehensive approaches, both staffs of medical social service and welfare division of Tokyo University Hospital and we develop the new system which bridge between in-patients and out-patients in terms of maintaining a constant level of quality of life of patients and caregivers.

Specialized services are provided to out-patients on a daily in all areas internal medicine. Approximately 300 new and a total of 16,000 patients visit the out-patients clinic in a year.

Faculties and Students

Professor and Chair	Yasuyoshi Ouchi, M.D. (1995-)
Lecturer	Yoshio Namba, M.D. Takahide Nagase, M.D. Satoshi Inoue, M.D. Koichi Kozaki, M.D.
Associate	6
Postdoctoral Fellow	4
Graduate Student	8
Research Student	5
Secretary	6

Past Research and Major Accomplishments

Lung diseases including pneumonia are major causes of death in the elderly. In respiratory diseases, there are several inflammatory disorders to which no pharmaceutical agents are currently effective. For

example, adult respiratory distress syndrome (ARDS) is an acute lung injury and the mortality rate for ARDS ranges from 40-70% despite of intensive care using currently available drugs. Idiopathic pulmonary fibrosis (IPF) is a progressive and fatal disease, while current medical intervention for IPF is only oxygen therapy except for lung transplantation. However, their mechanisms still remain to be elucidated. Therefore, we have aimed to elucidate the pathophysiological and molecular mechanisms underlying inflammatory diseases. Our recent studies have shown that various mediators including cytokines, eicosanoids or adhesion molecules are involved in the development of inflammatory lung disorders. Especially, platelet-activating factor (PAF) and metabolites of arachidonic acid, i.e., eicosanoids, are lipid mediators that have various biological effects. PAF is a proinflammatory phospholipid mediator that exerts its action via activation of G-protein-coupled PAF

receptor (PAFR). A key enzyme for the production of these inflammatory mediators including eicosanoids and PAF is cytosolic phospholipase A2 (cPLA2). To perform this study, we used mutant mice, i.e., PAFR transgenic mice, PAFR gene-disrupted mice, and cPLA2 gene-disrupted mice, in collaboration with Department of Biochemistry. Our observations suggest that both PAF and cPLA2 are involved in the pathogenesis of acute lung injury and pulmonary fibrosis. The inhibition of these pathways might provide a novel therapeutic approach to ARDS and IPF. We have also examined the host-defense system, especially antimicrobial peptides including defensins. Recently, we have discovered a novel mouse beta-defensin, mBD-6, predominantly expressed in skeletal muscle. In humans and mice, we have also identified multiple novel epididymis-specific beta-defensin isoforms. These findings suggest novel physiological roles of this peptide family.

Cardiovascular research laboratory has been performing research of atherosclerosis. It is generally accepted that premenopausal women are protected from atherosclerotic diseases because female hormone, especially estrogen, appears to have a beneficial effect on vascular wall. We have identified that vascular smooth muscle cells (VSMC) express estrogen receptor (ER) and these cells respond to estrogen from the evidence that estrogen inhibits endothelin-1 production and c-fos gene expression in rat aorta and estrogen inhibits migration and proliferation of vascular smooth muscle cells. We also found estrogen exerts beneficial effect *in vivo* by showing that estrogen inhibits intimal thickening of rat femoral artery induced by cuff-placement around the artery. With respect to endothelial cells (EC), another major component constituting the vascular wall, we found that estrogen attenuates endothelin-1 production in bovine endothelial cells via estrogen receptor and that estrogen prevents oxidative stress-induced endothelial cell apoptosis in rats.

Besides estrogen, we have revealed that red wine polyphenols (RWPs) have inhibitory roles in VSMC function. RWPs inhibit VSMC proliferation, which is mediated by cyclin A downregulation. RWPs also inhibit VSMC migration via two distinct signaling pathways, phosphatidylinositol-3' kinase and p38 mitogen-activated protein kinase. We also showed potential involvement of various vasoactive substances, calcitonin gene-related peptide, parathyroid hormone-related protein, vasopressin, and activin-A, in the pathogenesis of atherosclerosis.

From the clinical perspective, our laboratory has a useful technique to evaluate vascular function, flow-mediated vasodilatation (FMD). With this approach, we have shown that endothelium-dependent vasodilatation of the brachial artery is increased in the follicular and luteal phase of women's menstrual cycle

when serum estradiol level is high, indicating that endogenous estradiol is involved in menstrual cycle-related vasodilatation. We also found that FMD is impaired in obese men with visceral fat accumulation, FMD negatively correlates with intima-media thickness in the carotid artery in men, long-term reduced-dose hormone replacement therapy improves FMD and intima-media thickness in the carotid artery in postmenopausal women.

Currently, most of the research activities in neurological laboratory focus on the molecular aspects of Alzheimer's disease (AD). The main research topics are elucidating the molecular mechanism underlying the accumulation of amyloid β -protein, determining the implications of apolipoprotein E (apoE ϵ 4) genotype and various risk factors in AD.

Endocrine/Metabolism Research Laboratory focuses on the clinical and basic research concerning endocrine and metabolic diseases. We are particularly interested in the pathophysiological mechanisms in osteoporosis and hormone-dependent cancers. Regarding osteoporosis, we have shown that genetic factors are very important to develop the disease by analyzing polymorphisms of the genes relating bone metabolism. On the other hand, we recently have revealed that an estrogen responsive RING finger protein Efp takes a critical role in estrogen-dependent growth control of breast tumor, by proteolysis of a cell-cycle checkpoint 14-3-3 sigma (Nature 2002, 417, 871). This finding may provide a new tool for diagnosis and treatment of breast tumor, especially of tumor that is resistant to anti-estrogenic drugs.

We have also studied disuse syndrome as well as the program of prevention and treatment of that. Now we are investigating many aspects of elderly patients by using newly developed geriatric scale.

Current Research

To further investigate the pathophysiological and molecular mechanisms underlying inflammatory diseases, we continue to study the roles of various mediators including cytokines, eicosanoids, adhesion molecules, and CGRP family in the development of inflammatory lung disorders. Especially, CGRP family peptides including CGRP and adrenomedullin are neuropeptides that have various biological actions such as responses to sensory stimuli, cardiovascular regulation and vasodilation. Based on their physiological roles, it is assumed that CGRP family might be involved in the pathogenesis of inflammatory diseases including bronchial asthma. Currently, in collaboration with Department of Cardiovascular Medicine, we are studying the pathophysiological role of CGRP family using mutant mice deficient in either CGRP or

adrenomedullin.

High incidence of respiratory infection including pneumonia is a major characteristic of geriatric disease, while little is known about its mechanism. We currently hypothesize that ageing process might affect the expression pattern of defensins, leading to the susceptibility to infection in the elderly. To address this question, we are studying the ageing effects on the expression pattern of defensins using mice. In addition, to better understand the pathophysiological roles of defensins, we are now developing the mutant mice deficient in defensins.

We are currently pursuing the differential role of estrogen receptors, ER α and β , in VSMC function and in other cell types utilizing adenoviral overexpression system, because we have previously shown that estrogen has anti-proliferative and anti-migratory effects in VSMC (Atherosclerosis. 1997). We are also trying to overexpress each ER subtype in the aorta of laboratory animals to identify the differential role of ER in estrogen's action. We are studying the role of selective estrogen receptor modulator such as raloxifene to explore the usefulness of this new estrogen-modifying drug.

Our laboratory has been investigating vascular calcification, one of the hallmarks of vascular aging. We have thus far found that VSMC calcify when cultured in the presence of high inorganic phosphate, the phenomenon augmented by the addition of vitamin D₃, dexamethasone and advanced glycation end products, attenuated by bisphosphonate and HMG CoA reductase inhibitor. We are currently studying the mechanism how VSMC calcification is regulated.

It is well known that flow-mediated vasodilatation (FMD) is under much influence by nitric oxide (NO). Because it has been shown that an endogenous inhibitor of NO synthase, asymmetric dimethylarginine (ADMA), and its hydrolyzing enzyme, NG,NG-dimethylarginine dimethylaminohydrolase (DDAH), are circulating in human blood, we are interested in the role of ADMA and DDAH in such pathophysiological conditions as pre- and post-female hormone replacement therapy and pre- and post-treatment of sleep apnea syndrome using nasal continuous positive airway pressure.

The ϵ 4 allele of apoE is a major risk factor for both sporadic and late-onset familial AD. The apoE receptor family consists of cell-surface receptors that recognize extracellular ligands and internalize them for degradation by lysosomes. In order to gain insight about these receptors in the CNS, we raised a rabbit polyclonal antibody and examined immunohistochemically human brain tissue. The immunoreactivity was found in senile plaque in AD. These results may suggest a role of apoE receptor in amyloid formation.

As estrogen is one of the key factors that can

determine the stages and prognosis of osteoporosis and hormone-dependent cancers, we are particularly studying the molecular mechanism of estrogen in its target organs. Biochemical and genetic approaches are utilized for the project, including analysis using osteoblasts and tumor cell lines, characterization of animal models targeting estrogen receptors and estrogen-responsive genes, genetic analysis using clinical samples from patients.

Future Prospects

Major causes of death in the elderly include respiratory diseases including pneumonia, especially aspiration pneumonia. Furthermore, there are fatal inflammatory disorders such as ARDS and IPF, to which no useful drugs are currently available. We expect that the inhibition of PAF and cPLA2 pathways might provide a novel therapeutic approach to ARDS and IPF, leading to the development of a revolutionary medicine.

Genetic features including single nucleotide polymorphism (SNP) are potentially associated with the etiology of asthma. The current study may suggest that CGRP family genes could be targets for SNP research. High incidence of respiratory infection including pneumonia in the elderly might be explained by the mechanism that ageing process might alter the expression pattern of defensins, leading to the immunosuppression and the susceptibility to infection. We expect that our ongoing study related to defensins could make a contribution to the innate-immunity researches. Furthermore, novel roles of defensins might potentially provide a novel therapeutic approach to infectious diseases.

Because the aging process and age-related diseases are closely associated with vascular aging, to prevent atherosclerosis is a way to improve physical activity in the elderly. Our laboratory keeps pursuing the mechanism of atherosclerosis, especially how hormone and its receptor regulate vascular function. We will keep performing research as to how sex hormones or their related biological materials modulate vascular function in vitro and in vivo. We will also try to elucidate the mechanism how we can reduce vascular calcification, because vascular calcification appears tightly linked with vascular aging, which is one of our interests.

We are studying the genetic and environmental risk factors and prevalence, and incidence of Alzheimer's disease among the elderly in Japan.

Because estrogen is one of the key factors that can determine the stages and prognosis of osteoporosis, hormone-dependent cancers, and age-related changes of females, we are pursuing prevention and new treatment of osteoporosis and cancer. It may contribute

to maintain the constant level of physical and social activity in elderly peoples. Furthermore, our basic research focuses on novel findings of new molecular targets for drug development concerning osteoporosis and hormone-dependent cancers.

Based on these clinical and basic science data, we are pursuing prevention of a variety of age-related diseases and geriatric syndrome. We also propose standards for facilitation of care across the health service continuum, care of the nursing home resident, and palliative and hospice care.

Research Grants

Yasuyoshi Ouchi

1. Grant-in Aid (No.13557062) for Scientific Research from the Ministry of Education, Science and Culture of Japan. Elucidation of the differential role of estrogen receptor α and β in vascular lesion formation. 1999-2001 (three year research foundation grant B2).
2. Funds for Comprehensive Research on Aging and Health, Japan Foundation for Aging and Health. Hormone replacement therapy for elderly women. Yasuyoshi Ouchi 1998-2000 (three year grant, H10-tyojyu-007).

Nagase Takahide

1. Grant-in Aid (No. 12470134) for Scientific Research from the Ministry of Education, Science, Sports and Culture of Japan. The study of molecular mechanisms underlying ARDS using genetically-engineered mice to develop a novel treatment (three year research foundation grant B).
2. Health Science Research Grant-in Aid for Comprehensive Research on Aging and Health from the Ministry of Health, Labour and Welfare of Japan. The study of pathophysiological mechanisms underlying inflammatory/intractable lung diseases in the elderly: a strategic development of novel therapeutic approaches (H14).

Yoshio Namba

1. Health Science Research Grant-in Aid for Brain Science from the Ministry of Health and Welfare of Japan. Genetic and environmental risk factors for Alzheimer's disease (three year grant, H10-H12).

Select Publications

1. Urano T, Saito T, Tsukui T, Fujita M, Hosoi T, Muramatsu M, Inoue S: Efp targets 14-3-3 σ for proteolysis and promotes breast tumour growth. *Nature* 417, 871-875, 2002.
2. Nagase T, Uozumi N, Ishii S, Kita Y, Yamamoto H, Ohga E, Ouchi Y, Shimizu T. A pivotal role of cytosolic phospholipase A2 in bleomycin-induced pulmonary fibrosis. *Nature Med* 8: 480-484, 2002.

3. Nagase T, Ishii S, Shindou H, Ouchi Y, Shimizu T. Airway hyperresponsiveness in transgenic mice over-expressing platelet activating factor receptor is mediated by an atropine sensitive pathway. *Am J Respir Crit Care Med* 165: 200-205, 2002.
4. Hashimoto M, Miyao M, Akishita M, Hosoi T, Toba K, Kozaki K, Yoshizumi M, Ouchi Y. Effects of long-term and reduced-dose hormone replacement therapy on endothelial function and intima-media thickness in postmenopausal women. *Menopause*. 9:58-64, 2002.
5. Iijima K, Yoshizumi M, Hashimoto M, Akishita M, Kozaki K, Ako J, Watanabe T, Ohike Y, Son B, Yu J, Nakahara K, Ouchi Y. Red wine polyphenols inhibit vascular smooth muscle cell migration through two distinct signaling pathways. *Circulation*. 105:2404-2410, 2002.
6. Kageyama A, Hirano T, Kageyama H, Osaka T, Namba Y, Tsuji M, Adachi M, Inoue S. Distinct role of adiposity and insulin resistance in glucose intolerance: studies in ventromedial hypothalamic-lesioned obese rats. *Metabolism*. 51:716-23, 2002.
7. Kaneki M, Hedges SJ, Hosoi T, Fujiwara S, Lyons A, Crean SJ, Ishida N, Nakagawa M, Takechi M, Sano Y, Mizuno Y, Hoshino S, Miyao M, Inoue S, Horiki K, Shiraki M, Ouchi Y, Orimo H: Japanese fermented soybean food as the major determinant of the large geographic difference in circulating levels of vitamin K2: possible implications for hip-fracture risk. *Nutrition* 17, 315-21, 2001.
8. Sudoh N, Toba K, Akishita M, Ako J, Hashimoto M, Iijima K, Kim S, Liang YQ, Ohike Y, Watanabe T, Yamazaki I, Yoshizumi M, Eto M, Ouchi Y. Estrogen prevents oxidative stress-induced endothelial cell apoptosis in rats. *Circulation*. 103:724-729, 2001.
9. Yamaguchi Y, Fukuhara S, Nagase T, Tomita T, Hitomi S, Kimura S, Kurihara H, Ouchi Y. A novel mouse beta-defensin, mBD-6, predominantly expressed in skeletal muscle. *J Biol Chem* 276: 31510-31514, 2001.
10. Ishikawa M, Akishita M, Kozaki K, Toba K, Namiki A, Yamaguchi T, Orimo H, Ouchi Y. Expression of parathyroid hormone-related protein in human and experimental atherosclerotic lesions: functional role in arterial intimal thickening. *Atherosclerosis*. 152:97-105, 2000.
11. Inoue S, Ogawa S, Horie K, Hoshino S, Goto W, Hosoi T, Tsutsumi O, Muramatsu M, Ouchi Y: An estrogen receptor beta (ER beta) Isoform that lacks exon 5 has dominant negative activity on both ER alpha and ER beta. *Biochem Biophys Res Commun* 279, 814-819, 2000.
12. Miyao M, Hosoi T, Emi M, Nakajima T, Inoue S, Hoshino S, Shiraki M, Orimo H, Ouchi Y: Association of bone mineral density with a dinucleotide repeat polymorphism at the calcitonin (CT) locus. *J Hum Genet* 45: 346-350, 2000.
13. Ogawa S, Emi M, Shiraki M, Hosoi T, Ouchi Y, Inoue S: Association of estrogen receptor beta (ESR2) gene

- polymorphism with blood pressure. *J Hum Genet* 45: 327-330, 2000.
14. Ogawa S, Fujita M, Ishii Y, Tsurukami H, Hirabayashi M, Ikeda K, Orimo A, Hosoi T, Ueda S, Nakamura T, Ouchi Y, Muramatsu M, Inoue S: Impaired estrogen sensitivity in bone by inhibiting both estrogen receptor alpha and beta pathways. *J Biol Chem* 275: 21372-21379, 2000.
 15. Hoshino S, Hosoi T, Miyao M, Shiraki M, Orimo H, Ouchi Y, Inoue S: Identification of a novel polymorphism of estrogen receptor alpha gene that is associated with calcium excretion in urine. *J Bone Miner Metab* 18: 153-157, 2000.
 16. Urano T, Hosoi T, Shiraki M, Toyoshima H, Ouchi Y, Inoue S: Possible involvement of p57Kip2 gene in the bone metabolism. *Biochem Biophys Res Commun* 269: 422-426, 2000.
 17. Miyao M, Morita H, Hosoi T, Kurihara H, Inoue S, Hoshino S, Shiraki M, Yazaki Y, Ouchi Y: Association of methylenetetrahydrofolate reductase (MTHFR) polymorphism with bone mineral density in postmenopausal Japanese women. *Calcif Tissue Int* 66: 190-194, 2000.
 18. Nagase T, Uozumi N, Ishii S, Kume K, Izumi T, Ouchi Y, Shimizu T. Acute lung injury by sepsis and acid aspiration: a key role for cytosolic phospholipase A2. *Nature Immunol* 1: 42-46, 2000.
 19. Iijima K, Yoshizumi M, Hashimoto M, Kim S, Eto M, Ako J, Liang YQ, Sudoh N, Hosoda K, Nakahara K, Toba K, Ouchi Y. Red wine polyphenols inhibit proliferation of vascular smooth muscle cells and down-regulate expression of cyclin A gene. *Circulation*. 101:805-811, 2000.
 20. Nagano K, Toba K, Akishita M, Watanabe T, Kozaki K, Eto M, Hashimoto M, Sudoh N, Ako J, Yoshizumi M, Ouchi Y. Prostanoids regulate proliferation of vascular smooth muscle cells induced by arginine vasopressin. *Eur J Pharmacol*. 389:25-33, 2000.
 21. Hashimoto M, Eto M, Akishita M, Kozaki K, Ako J, Iijima K, Kim S, Toba K, Yoshizumi M, Ouchi Y. Correlation between flow-mediated vasodilatation of the brachial artery and intima-media thickness in the carotid artery in men. *Arterioscler Thromb Vasc Biol*. 19:2795-2800, 1999.
 22. Motoi Y, Aizawa T, Haga S, Nakamura S, Namba Y, Ikeda K. Neuronal localization of a novel mosaic apolipoprotein E receptor, LR11, in rat and human brain. *Brain Res*: 833:209-215, 1999.
 23. Namba Y, Ouchi Y, Takeda A, Ueki A, Ikeda K. bleomycin hydrolase immunoreactivity in senile plaque in the brains of patients with Alzheimer's disease. *Brain Res*: 830:200-202, 1999.
 24. Namba Y, Ouchi Y, Asada T, Ueki A and Ikeda K. Lack of association between bleomycin hydrolase gene polymorphism and Alzheimer's disease in Japanese people. *Ann Neurol*, 46:136-137, 1999.
 25. Nagase T, Kurihara H, Kurihara Y, Aoki-Nagase T, Nagai R, Ouchi Y. Disruption of ET-1 gene enhances pulmonary responses to methacholine via functional mechanism in knockout mice. *J Appl Physiol* 87:2020-2024, 1999.
 26. Nagase T, Ishii S, Kume K, Uozumi N, Izumi T, Ouchi Y, Shimizu T. Platelet-activating factor mediates acid-induced lung injury in genetically engineered mice. *J Clin Invest* 104: 1071-1076, 1999.
 27. Ohga E, Nagase T, Tomita T, Teramoto S, Matsuse T, Katayama H, Ouchi Y. Increased levels of circulating ICAM-1, VCAM-1, and L-selectin in obstructive sleep apnea syndrome. *J Appl Physiol* 87: 10-14, 1999.
 28. Nagase T, Kurihara H, Kurihara Y, Aoki T, Fukuchi Y, Yazaki Y, Ouchi Y. Airway hyperresponsiveness to methacholine in mutant mice deficient in endothelin-1. *Am J Respir Crit Care Med* 157: 560-564, 1998.
 29. Hashimoto M, Akishita M, Eto M, Kozaki K, Ako J, Sugimoto N, Yoshizumi M, Toba K, Ouchi Y. The impairment of flow-mediated vasodilatation in obese men with visceral fat accumulation. *Int J Obes Relat Metab Disord*.22:477-484, 1998.
 30. Akishita M, Kozaki K, Eto M, Yoshizumi M, Ishikawa M, Toba K, Orimo H, Ouchi Y. Estrogen attenuates endothelin-1 production by bovine endothelial cells via estrogen receptor. *Biochem Biophys Res Commun*. 251:17-21, 1998.
 31. Ishikawa M, Akishita M, Kozaki K, Toba K, Namiki A, Yamaguchi T, Orimo H, Ouchi Y. Amino-terminal fragment (1-34) of parathyroid hormone-related protein inhibits migration and proliferation of cultured vascular smooth muscle cells. *Atherosclerosis*. 136:59-66, 1998.
 32. Kozaki K, Akishita M, Eto M, Yoshizumi M, Toba K, Inoue S, Ishikawa M, Hashimoto M, Kodama T, Yamada N, Orimo H, Ouchi Y. Role of activin-A and follistatin in foam cell formation of THP-1 macrophages. *Arterioscler Thromb Vasc Biol*. 17:2389-2394, 1997.
 33. Akishita M, Ouchi Y, Miyoshi H, Kozaki K, Inoue S, Ishikawa M, Eto M, Toba K, Orimo H. Estrogen inhibits cuff-induced intimal thickening of rat femoral artery: effects on migration and proliferation of vascular smooth muscle cells. *Atherosclerosis*. 130:1-10, 1997.
 34. Shiraki M, Shiraki Y, Aoki C, Hosoi T, Inoue S, Kaneki M, Ouchi Y: Association of Bone mineral density with apolipoprotein E phenotype. *J Bone Miner Res*12: 1438-1445, 1997.
 35. Nagano K, Toba K, Akishita M, Kozaki K, Eto M, Hashimoto M, Sudoh N, Yoshizumi M, Ouchi Y. Identification of arginine vasopressin mRNA in rat aortic smooth muscle cells. *Biochem Biophys Res Commun*. 231:831-834, 1997.
 36. Nagase T, Ishii S, Katayama H, Fukuchi Y, Ouchi Y, Shimizu T. Airway responsiveness in transgenic mice overexpressing platelet activating factor receptor: roles of thromboxanes and leukotrienes. *Am J Respir Crit Care Med* 156: 1621-1627, 1997.
 37. Nagase T, Aoki T, Oka T, Fukuchi Y, Ouchi Y. ET-induced bronchoconstriction is mediated via ETB receptor in mice. *J Appl Physiol* 83: 46-51, 1997.

38. Uozumi N, Kume K, Nagase T, Nakatani N, Ishii S, Tashiro F, Komagata Y, Maki K, Ikuta K, Ouchi Y, Miyazaki J, Shimizu T. Role of cytosolic phospholipase A2 in allergic response and parturition. *Nature* 390: 618-622, 1997.
39. Akishita M, Ouchi Y, Miyoshi H, Orimo A, Kozaki K, Eto M, Ishikawa M, Kim S, Toba K, Orimo H. Estrogen inhibits endothelin-1 production and c-fos gene expression in rat aorta. *Atherosclerosis*. 125:27-38, 1996.
40. Inoue S, Hoshino S, Miyoshi H, Akishita M, Hosoi T, Orimo H, Ouchi Y: Identification of a novel isoform of estrogen receptor, a potential inhibitor of estrogen action, in vascular smooth muscle cells. *Biochem Biophys Res Commun* 219: 766-772, 1996.
41. Kobayashi S, Inoue S, Hosoi T, Ouchi Y, Shiraki M, Orimo H: Association of bone mineral density with polymorphism of the estrogen receptor gene. *J Bone Miner Res* 11: 306-311, 1996.
42. Nagase T, Ohga E, Katayama H, Sudo E, Aoki T, Matsuse T, Ouchi Y, Fukuchi Y. Roles of calcitonin gene-related peptide (CGRP) in hyperpnea-induced constriction in guinea pigs. *Am J Respir Crit Care Med* 154: 1551-1556, 1996.
43. Hashimoto M, Akishita M, Eto M, Ishikawa M, Kozaki K, Toba K, Sagara Y, Taketani Y, Orimo H, Ouchi Y. Modulation of endothelium-dependent flow-mediated dilatation of the brachial artery by sex and menstrual cycle. *Circulation*. 92:3431-3435, 1995.
44. Okuizumi K, Onodera O, Namba Y, Ikeda K, Yamamoto T, Ueki A, Nanko S, Tanaka H, Takahashi H, Oyanagi S, Tsuji S. Genetic association of the very low density lipoprotein (VLDL) receptor gene with sporadic Alzheimer's disease. *Nature Genet*, 11:207-209, 1995.
45. Ishikawa M, Ouchi Y, Akishita M, Kozaki K, Toba K, Namiki A, Yamaguchi T, Orimo H. Immunocytochemical detection of parathyroid hormone-related protein in vascular endothelial cells. *Biochem Biophys Res Commun*. 199:547-551, 1994.
46. Ishikawa M, Ouchi Y, Han SZ, Akishita M, Kozaki K, Toba K, Namiki A, Yamaguchi T, Orimo H. Parathyroid hormone-related protein reduces cytosolic free Ca²⁺ level and tension in rat aortic smooth muscle. *Eur J Pharmacol*. 269:311-317, 1994.
47. Orimo A, Inoue S, Ikegami A, Hosoi T, Akishita M, Ouchi Y, Muramatsu M, Orimo H. Vascular smooth muscle cells as target for estrogen. *Biochem Biophys Res Commun*. 195:730-736, 1993.
48. Ishikawa M, Ouchi Y, Orimo H. Effect of calcitonin gene-related peptide on cytosolic free Ca²⁺ level in vascular smooth muscle. *Eur J Pharmacol*. 246:121-128, 1993.
49. Namba Y, Tomonaga M, Kawasaki H, Otomo E, Ikeda K. Apolipoprotein E immunoreactivity in cerebral amyloid deposits and neurofibrillary tangles in Alzheimer's disease and kuru plaque amyloid in Creutzfeldt-Jakob disease. *Brain Res*, 541:163-166, 1991.

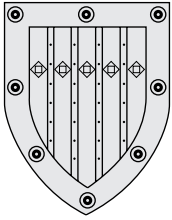

Department of Cardiothoracic Surgery

Outline and Research Objectives

Our department specializes in all areas of cardiothoracic surgery including congenital and acquired cardiac diseases, thoracic and abdominal aortic diseases, and benign and malignant diseases of respiratory and mediastinal organs, except for diseases of the esophagus and mammary glands. The Department of Cardiothoracic Surgery, University of Tokyo, was established in December 15, 1964 as the first department of this field in the Japanese national universities. Since then it has played an internationally leading role and contributed to development of the field. Professors and Chairs in the history of the department are as follows; Seiji Kimoto (1964.12.15 ~ 1968.3.31), Masahiro Saigusa (1968.4.1 ~ 1981.3.31), Ken-ichi Asano (1981.4.1 ~ 1986.3.31), Akira Furuse (1986.4.1 ~ 1997.3.31) and Shinichi Takamoto (1997.6.1 ~). The cardiothoracic department of the University of Tokyo has created highly active research programs in the every field of cardiothoracic surgery. Recently, most of the basic research activities are focused in the fields of brain and spinal cord protection during aortic surgery, homo- and xeno-transplantation of the heart, lung, heart valves and trachea, and surgical oncology of the pulmonary and thymic neoplasms. Although, there are many other active research projects such as stent-graft repair for thoracic aortic aneurysm, minimally invasive cardiac surgery, and intraoperative real-time 3-D echocardiography.

Faculties and Students

Professor and Chair Shinichi Takamoto, M.D. (1997-)
 Associate Professors Yutaka Kotsuka, M.D.
 Jun Nakajima, M.D.
 Lecturer Arata Murakami, M.D. and
 Toshiya Ohtsuka, M.D.
 Associate8
 Graduate Students10
 Research Students.....1

Past Research and Major Accomplishments

Dr. Takamoto invented a new method of brain protection during surgery of a distal arch aneurysm under deep hypothermia (Fig 1). The new method is a kind of retrograde cerebral perfusion, which simplify the retrograde perfusion system for patients of distal aortic arch aneurysm. This new method has been accepted as a standard procedure of a distal arch replacement in all over the world. The method has been applied to many patients, and it was clarified that the method provides a prolongation of safety limits of circulatory arrest and a beneficial effect in prevention of brain embolism.

Allograft tissue has several advantages in that anti-infection, softness, and less compliance mismatching. Cell viability of the tissue can be maintained for more than hundred years if properly preserved under the liquid nitrogen. We started basic study on homografts

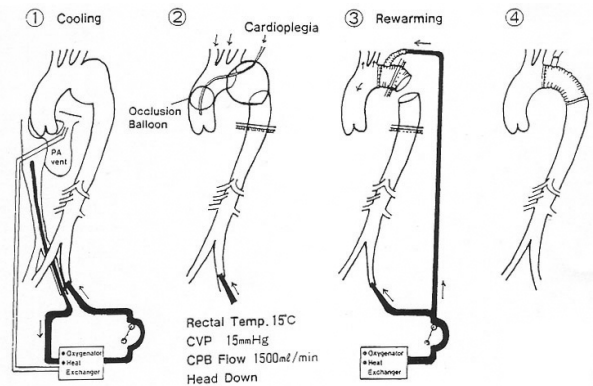

Fig 1

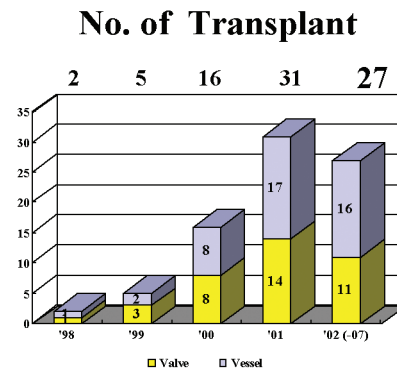

Fig 2

tissue transplantation including the cardiac valve, aorta and trachea 8 years ago. We founded the University of Tokyo Tissue Bank (UTTB) in 1999, where human cardiac valves, vessels and tracheas

obtained from non-brain dead donors are cryopreserved. Cardiac valves are used for the patients of infective endocarditis, congenital heart disease. Vessels are used for artificial graft infection, liver transplant recipients. The number of donor and usage of these allograft tissues are increasing every year, and more and more patients are being saved with these allograft tissues (Fig 2).

As for clinical activities, surgical cases are remarkably increasing as shown in the table below.

Table 1: Patients who underwent surgery in the department

	1997	1998	1999	2000	2001
Cardiovascular	152	157	179	225	272
General Thoracic	178	202	170	197	185
Total	330	359	349	422	457

Current Research

Thirteen staff members including professors and lecturers all participate not only in surgeries but also patient care on both in-patient and out-patient bases. They are all engaged in research activities for clinical and experimental subjects. As the subjects of cardiothoracic surgical fields are so close one another, we do not have sectioned research groups within our department. Instead, we make a project team for each research subject with most appropriate staff members and residents. Every associate takes part in at least one to several project teams. Main subjects of current research includes brain and spine protection during aortic surgery, homo- and xeno-transplantation of the heart, lung, heart valves and and trachea, surgical oncology of the pulmonary and thymic neoplasms, stent-graft repair for thoracic aortic aneurysm, minimally invasive cardiac surgery, and intraoperative 3-D echocardiography.

Spinal cord protection: Paraplegia remains one of the most serious complications after thoracoabdominal aortic aneurysm repair. In order to prevent paraplegia, it is important to identify and preserve critical segmental arteries. We developed new method to identify critical segmental artery. The ultrasonographic evaluation of the hemodynamics of intercostal arteries was the key to identify critical segmental artery (Fig 3).

Cryopreserved allotransplantation: Cryopreserved allogeneic heart valves and vessels have come to be widely utilized in cardiothoracic surgery because of their excellent durability. We have studied the allogenicity of the cryopreserved tissues using cell cultures of the airway epithelium, vascular endothelium, and fibroblasts. We have investigated whether cryopreserved tracheal allotransplantation is applicable. Experimental cryopreserved tracheal allotransplanta-

tion was performed in primates, which have a closer anatomical and immunological relation with humans than other animals, to confirm the possible clinical feasibility of cryopreserved tracheal allotransplantation. Immunogenicity was attenuated by cryopreservation, and cryopreserved tracheal allografts were incorporated in all animals (Fig 4).

Stent-graft repair: We developed ultrathin-wall vascular grafts with a wall thickness of 42 to 137 μ m for endovascular surgery. We studied the physical properties of the ultrathin-wall grafts in in vitro experiments. We conclude that the newly developed ultrathin-wall grafts are suitable for endovascular surgery (Table 2).

After animal experiments, we applied the grafts to clinical patients with good results. We also developed auto-swelling vascular grafts, using ultrathin-wall Dacron vascular grafts and superabsorbent polymer. These grafts were designed to prevent endoleak following stent-graft repair of aortic aneurysm. Stent-grafts covered with auto-swelling grafts are expected to have beneficial effects in preventing endoleak.

Minimally invasive cardiac surgery: We have been using minimally invasive techniques in various procedures of thoracic and cardiac surgery. We have employed video-assisted thoracoscopic surgery (VATS) for pulmonary or mediastinal surgery since 1992. We have made retrospective studies on feasibility and surgical outcome of VATS for diagnosis and treatment of lung neoplasms. We have concluded that VATS for diagnosing pulmonary indeterminate nodules and

fig3

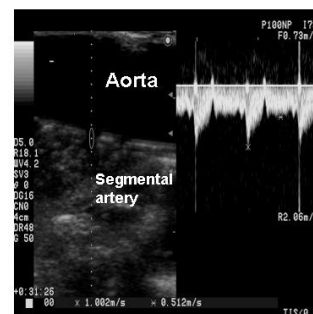

Fig.1: Segmental arteries are clearly identified with a 5MHz epiaortic scanning probe. The flow velocities of segmental arteries are measured with pulsed Doppler ultrasonography

fig4



Table 2

Wall thickness (μm)	137	117	95	85	75	64	50	42
Transverse Microscopic Porosity (μm)	0	0	0	0	0	11.3 \pm 13.6	57.4 \pm 25.0	75.9 \pm 18.8
Longitudinal Microscopic Porosity (μm)	0	0	0	0	0	36.9 \pm 7.8	39.0 \pm 7.9	132.3 \pm 7.8
Planimetric Porosity (μm^2)	0	0	0	0	0	416 \pm 494	2,238 \pm 1193	>10,000
Longitudinal Tensile Strength (Kg)	22.5 \pm 2.0	19.4 \pm 1.2	15.3 \pm 0.8	14.1 \pm 1.8	13.1 \pm 0.9	9.5 \pm 0.9	7.4 \pm 0.5	–
Water Permeability (ml/min/cm ²)	330 \pm 17	220 \pm 20	250 \pm 36	180 \pm 17	380 \pm 53	1,700 \pm 361	2,960 \pm 443	3,840 \pm 668

fig5

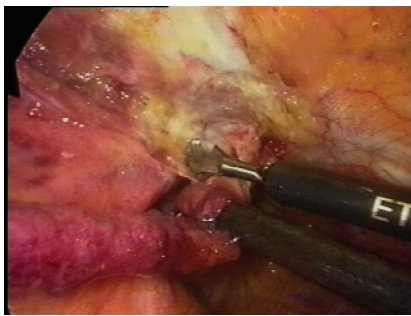

VATS for pulmonary metastasectomy are justified as a standard therapeutics. Off-pump coronary artery bypass is achieved without hemodynamic assistance by cardiopulmonary bypass, and it has been applied to increasing number of patients with multi-vessel ischemic heart disease. A single bypass from the internal mammary artery (IMA) to the left anterior descending coronary artery has been accomplished via a mini-thoracotomy approach. Valvular disease or atrial septal defect have been repaired via a limited sternotomy using a special retractor and port-accessible heart-lung machine. Video-endoscopy has been positively used for minimally invasive approach. Thoracoscopy has been used for mobilization of IMA graft (Fig 5), and cardioscopy has been used in valvular repair, correction of intra-cardiac anomaly, and left-atrial cryo-ablation.

Real-time 3-D echocardiography: We have developed real-time three-dimensional echocardiography (RT3DE) and applied it to monitoring heart operations, especially ASD closure, as a means of assisting treatment (Fig 6). In the animal experiment, ASD was successfully closed by RT3DE monitoring, and examination of the excised heart showed that all sutures were located, and the reliability of the images obtained by RT3DE was confirmed.

Surgical oncology of the thymic neoplasms: To classify the thymic epithelial neoplasms, the maturation stage of T-lineage lymphoid cells infiltrating thymic neoplasms (TIL) was examined by flow-

fig6

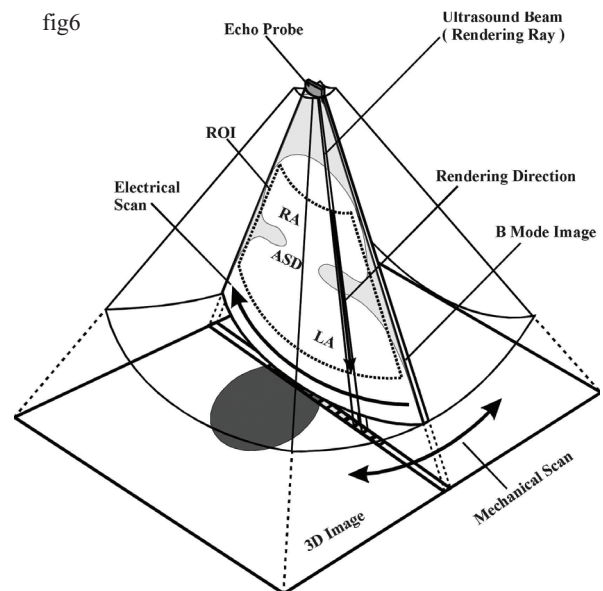

cytometry to associate it with the degree of tumor malignancy. CD4⁺CD8⁺ or CD10⁺ T-lineage cells were the most reliable markers of the benignancy of thymic epithelial tumors. CD4 / CD8 single positive cells or CD20-positive cells were characteristic in thymic carcinoma. Flow-cytometry on the maturity of lymphoid cells infiltrating thymic epithelial tumors was feasible for determining their degree of malignancy. Recently we have investigated T-cell receptor (TCR) gene rearrangement of the TIL. We have observed the appearance of clonal bands in TCR-beta and gamma, suggesting that partial gene rearrangement occurred in the TIL.

Future Prospects

Cardiac Transplantation is established treatment in the world. However, this treatment has not been well developed in Japan due to domestic reasons. We are now preparing clinical cardiac transplantation. We are going to develop basic and clinical research on cardiac transplantation as well as clinical application.

Research Grants

1. Grant-in Aid for Scientific Research from the Japanese Ministry of Education, Science, Sports and Culture (A)(1): Studies on management of heart transplant recipients and maintenance of donor organs. 1998-2000
2. Grant-in-Aid for Publication of Scientific Research Results: Japan Adult Cardiovascular Surgery Database. 2002
3. Grant-in-Aid for University and Society Collaboration: Establishment of Tissue Banking System on the basis of regional linkage. 2000-2002
4. Grant-in Aid for Scientific Research from the Japanese Ministry of Education, Science, Sports and Culture (B)(2): Basic and clinical study on percutaneous endovascular surgery with ultrathin-wall vascular grafts. 1997-1998
5. Grant-in Aid for Scientific Research from the Japanese Ministry of Education, Science, Sports and Culture (B)(2): Development of auto-swelling vascular grafts using super-absorbent polymer. 1999-2001

Select Publications

1. Imanaka, K., Takamoto S, Furuse A. Mitral regurgitation late after Manouguian's anulus enlargement and aortic valve replacement. *J Thorac Cardiovasc Surg* 115, 727-9, 1998.
2. Ono, M, Takamoto S, Ohtsuka T. Right ventricular rupture in a minimally invasive direct coronary artery bypass grafting. *Eur Journal Cardiothorac Surg* 14, 536-537, 1998.
3. Imanaka K, Shimizu S, Matsumoto J, Hashizume K, Tsuchiya K, Takemura T. Unilateral absence of pulmonary artery and ventricular defect in an infant. *Ann Thorac Surg* 66, 251-2, 1998.
4. Kawauchi M, Nakajima J, Takeda M, Oka T, Takamoto S. Aortic valves are antigenic but less so than myocardium. *J Thorac Cardiovasc Surg* 116, 532, 1998.
5. Miyaji K, Sugiura S, Omata S, Kaneko Y, Ohtsuka T, Takamoto S. Myocardial tactile stiffness: A variable of regional myocardial function. *J Am Coll Cardiol* 31, 1165-1173, 1998.
6. Kubota H, Takamoto S, Takeshita M, Miyaji K, Kotsuka Y, Furuse A. Atrial ablation with an IRK-151 infrared coagulator. *Ann Thorac Surg* 66, 95-100, 1998.
7. Ohtsuka T, Takamoto S, Endoh M, Ono M, Minami M. Ultrafast computed tomography for minimally invasive coronary artery bypass grafting. *J Thorac Cardiovasc Surg* 116, 173-4, 1998.
8. Ohtsuka T, Endoh M, Takamoto S. Minimally invasive left anterior descending coronary artery bypass with right gastroepiploic artery graft. *J Thorac Cardiovasc Surg* 116, 528-9, 1998.
9. Ohtsuka T. How high should mammary artery be harvested for the minimally invasive approach? *Ann Thorac Surg* 66, 985-6, 1998.

10. Kotsuka Y, Tanaka O, Takamoto S, Furuse A. Intravalvular implantation technique for aortic valve replacement in aortitis syndrome. *Ann Thorac Surg* 67, 89-92, 1999.
11. Imanaka K, Takamoto S, Murakami A, Kaneko Y. Minimally invasive extracardiac conduit replacement via a left anterior small thoracotomy. *J Thorac Cardiovasc Surg* 118, 1124-5, 1999.
12. Imanaka, K, Takamoto S, Kaneko Y, Murakami A, Shibuya K. Extracardiac conduit replacement with autologous tissue only, via a left anterior small thoracotomy. *Thorac Cardiovasc. Surg* 47, 251-2, 1999.
13. Imanaka, K, Takamoto S, Murakami A, Kaneko Y. Right ventricular thrombosis early after bidirectional Glenn shunt. *Ann Thorac Surg* 68, 563-5, 1999.
14. Ohtsuka T, Imanaka K, Endoh M, Kohno T, Nakajima J, Kotsuka Y, Takamoto S. Hemodynamic effects of carbon dioxide insufflation under single-lung ventilation during thoracoscopy. *Ann Thorac Surg* 68, 29-33, 1999.
15. Nakajima J, Poindexter NJ, Hillemeier PB, Trulock EP, Cooper JD, Patterson GA, Mohanakumar T, Sundaresan RS. Cytotoxic T lymphocytes directed against donor HLA class I antigens on airway epithelial cells are present in bronchoalveolar lavage fluid from lung transplant recipients during acute rejection. *J Thorac Cardiovasc Surg* 117, 565-71, 1999.
16. Nakajima J., Furuse A, Kohno T, Ohtsuka T, Matsumoto J, Oka T. Transthoracoscopic needle biopsy for indeterminate lung nodules. *Surgical Endoscopy* 13, 386-9, 1999.
17. Tanaka K, Takamoto S, Ohtsuka T, Kotsuka Y. Advaseal for acute aortic dissection: experimental study. *Eur J Cardio-thorac Surg* 15, 114-115, 1999.
18. Tanaka K, Takamoto S, Ohtsuka T, Kotsuka Y, Kawauchi M. Application of Advaseal for acute aortic dissection: experimental study. *Ann Thorac Surg* 68, 1308-1313, 1999.
19. Murakawa T, Nakajima J, Ono M, Murakami A, Suematsu Y, Takamoto S.: Allogenicity of cryopreserved human fibroblasts: cryopreservation does not downregulate the allogenicity of fibroblasts making up the matrices of allografts. *J Thorac Cardiovasc Surg* 120, 712-9, 2000.
20. Murakawa T, Nakajima J, Kohno T, Tanaka M, Matsumoto J, Takeuchi E, Takamoto S. Results from surgical treatment for thymoma: 43 years of experience. *Jpn J Thorac Cardiovasc Surg* 48, 89-95, 2000.
21. Kubota H, Furuse A, Kotsuka Y, Ninomiya M, Miyaji K, Endo M, & Takamoto S: Cardiac function evaluated by transesophageal echocardiography during cardiopulmonary bypass. *Jpn J Thorac Cardiovasc Surg* 48, 261-266, 2000.
22. Kubota H, Takamoto S, Kotsuka Y, & Furuse A: Successful treatment of massive pulmonary tumor embolism from renal cell carcinoma. *Ann Thorac Surg* 69, 972-3, 2000.
23. Kubota H, Takamoto S, Takeshita M, Miyaji K, Kotsuka Y, & Furuse A: Atrial ablation using an IRK-

- 151 infrared coagulator in canine model. *J Cardiovasc Surg* 4, 835-47, 2000.
24. Nakajima J, Takamoto S, Oka T, Tanaka M, Takeuchi E, Murakawa T : Flow cytometric analysis of lymphoid cells in thymic epithelial neoplasms. *Eur J Cardiothorac Surg* 18, 287-92, 2000.
 25. Nakajima J, Takamoto S, Tanaka M, Takeuchi E, Murakawa T : Thoracoscopic resection of the pulmonary aspergilloma - Report of two cases. *Chest* 118, 1490-2, 2000.
 26. Nakajima J, Takamoto S, Kohno T, Ohtsuka T: Costs of videothoracoscopic surgery versus open resection for patients with of lung carcinoma. *Cancer* 89, 2497-2501, 2000.
 27. Kotsuka Y, Ezure M, Kawauchi M, Takamoto S: Swinging motion of intimal flap through the aortic valve in acute aortic dissection. *J Cardiovasc Surg* 41, 395-397, 2000.
 28. Ono M., Takamoto S., Kawauchi M., Egami M., Kotsuka Y.: Aortobronchial fistula late after transverse arch replacement. *Ann Thorac Surg* 70, 964-6, 2000.
 29. Suematsu Y. Ohtsuka T. Miyaji K. Murakami A. Miyairi T. Eyleten Z. Kotsuka Y. Takamoto S. Right heart mini-pump bypass for coronary artery bypass grafting: experimental study. *Eur J Cardio-Thoracic Surg* 18, 276-81, 2000.
 30. Murakawa T, Nakajima J, Tanaka M, Karita M, Takamoto S.: Primary low-grade B-cell lymphoma in mucosa-associated lymphoid tissue of the lung. *Jpn J Thorac Cardiovasc Surg* 49, 621-4, 2001.
 31. Ohtsuka T, Suematsu Y, Kubota H, Takamoto S, Makuuchi M. Salvage of right gastroepiploic artery graft before pancreatoduodenectomy. *J Thorac Cardiothorac Surg* 121, 1013-4, 2001.
 32. Ohtsuka T, Kubota H, Motomura N, Takamoto S. Thoracoscopy for minimally invasive axillo-coronary artery bypass. *Eur J Cardiothorac Surg* 20, 856-7, 2001.
 33. Ohtsuka T, Nakajima J, Kotsuka Y, Takamoto S. Hemodynamic responses to intra-pleural insufflation with hemipulmonary collapse. *Surg Endosc* 15, 1327-30, 2001.
 34. Ohtsuka T, Takamoto S, Ono M, Motomura N. Aortic root replacement and coronary Interposition using a cryopreserved allograft and its branch. *Eur J Cardiothorac Surg* 20, 631-2, 2001.
 35. Mikio Ninomiya, Jun Nakajima, Makoto Tanaka, Eriho Takeuchi, Tomohiro Murakawa, Takeshi Fukami, Shinichi Takamoto: Effects of lung metastasectomy on respiratory function. *Jpn J Thorac Cardiovasc Surg* 49, 17-20, 2001.
 36. Mikio Ninomiya, Shinichi Takamoto, Yutaka Kotsuka, Takeshi Miyairi, Munemoto Endo: Stent-graft implantation through partial sternotomy. *J Thorac Cardiovasc Surg* 121: 992-993, 2001.
 37. Mikio Ninomiya, Shinichi Takamoto, Yutaka Kotsuka, Toshiya Ohtsuka: Indication and perioperative management for cardiac surgery in patients with liver chirrrosis: Our experience with 3 patients. *Jpn J Thorac Cardiovasc Surg* 49, 391-394, 2001.
 39. Mikio Ninomiya, Haruo Makuuchi, Toshiya Ohtsuka, Shinichi Takamoto: Ischemic heart disease associated with protein C deficiency. *Eur J Cardiothorac Surg* 20, 883-885, 2001.
 40. Mikio Ninomiya, Shinichi Takamoto, Yutaka Kotsuka, Takeshi Miyairi, Tetsuro Morota, Hiroshi Kubota: Midterm results after aortic valve-sparing operation. *Jpn J Thorac Cardiovasc Surgery* 49, 706-710, 2001.
 41. Ono M., Takamoto S., Miyairi T., Kubota H.: An extended repair of thoracic aorta through left thoracotomy after aortic root replacement. *Ann Vasc Surg* 15, 488-90, 2001.
 42. Ono M., Wolf R.K.: Heart injury and endocarditis caused by a needle migrated from the left arm. *Eur J Cardiothorac Surg* 20, 1073-4, 2001.
 43. Ueno K, Takamoto S, Miyairi T, Morota T, Shibata K, Murakami A, Kotsuka Y: Arterial blood gas management in retrograde cerebral perfusion: the importance of carbon dioxide. *Eur J Cardiothorac Surg.* 20, 979-85, 2001.
 44. Takeshi Miyairi, Yutaka Kotsuka, Tetsuro Morota, Hiroshi Kubota, Ko Shibata, Yorinobu Ikeda, Tadashi Kitamura, Takeshi Kashima, Shinichi Takamoto: Paraplegia after open surgery using endovascular stent grafting for aortic arch. *J Thorac Cardiovasc Surg* 122: 1240-3, 2001.
 45. Takeshi Miyairi, Shinichi Takamoto, Yutaka Kotsuka, Arata Murakami, Hiroshi Kubota, Toshiya Ohtsuka: Strategy for redo surgery on the thoracic aorta. *Keio University International Symposia for Life Science and Medicine*, Ed by S. Kawada, Vol. 7: 90-98, 2001. Tokyo.
 46. Suematsu Y. Takamoto S. Ohtsuka T. Intraoperative echocardiographic imaging of coronary arteries and graft anastomoses during coronary artery bypass grafting without cardiopulmonary bypass. *J Thorac Cardiovasc Surg* 122, 1147-54, 2001.
 47. Murakawa T, Nakajima J, Motomura N, Murakami A, Takamoto S.: Successful allotransplantation of cryopreserved tracheal grafts with preservation of the pars membranacea in nonhuman primates. *J Thorac Cardiovasc Surg* 123, 153-60, 2002.
 48. Kubota H, Takamoto S, Murakami A, Kotsuka Y, & Furuse A: Biologic glue-molded "bio-mini-paddle" electrode used for atrial and ventricular pacing and defibrillation. *Ann Thorac Surg* 322-4, 2002.
 49. Kotsuka Y, Ezure M, Tanaka K, Takamoto S, Kuwahara K, Ikeda H. Ultrathin-wall vascular grafts for endovascular surgery. *J Art Org* 5: 108-112, 2002.
 50. Suematsu Y. Ohtsuka T. Miyairi T. Motomura N. Takamoto S. Ultrasonic evaluation of graft anastomoses during coronary artery bypass grafting without cardiopulmonary bypass. *Ann Thorac Surg* 74, 273-5, 2002.

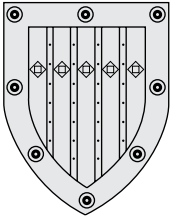

Department of Gastrointestinal Surgery / Department of Surgical Metabolism and Nutrition and Endocrine Surgery

Outline and Research Objectives

Since 2001, the former Third Department of Surgery, which was located in a branch hospital of the University of Tokyo, has been divided into two departments, the Department of Gastrointestinal Surgery and the Department of Surgical Metabolism and Nutrition and Endocrine Surgery, in line with the integration of the main and branch hospitals the elevation to a department in the graduate school of medicine at our university. Our research activities in both departments have been well organized and ultimately successful by maintaining a close connection.

The main research activities of the department of Gastrointestinal Surgery are focused on diagnosis and therapy for gastrointestinal diseases and clinical and basic research for gastrointestinal carcinogenesis. A historical and outstanding achievement of the department of Gastrointestinal Surgery is the successful innovation of the "Gastrocamera" a half century ago. Thereafter, we have been active in the diagnosis and treatment of gastric cancer and established the feasibility of extended gastrectomy with intraoperative chemotherapy for advanced cancer, and limited lymph node dissection for early gastric cancer. With a view to further development of research for gastrointestinal carcinogenesis, we established the Japanese Society for Gastroenterological Carcinogenesis in 1989, and have been studying the underlying mechanisms of development, progression and prevention of digestive cancer.

The department of Surgical Metabolism and Nutrition and Endocrine Surgery has been studying one of the most fundamental issues in surgery, i.e., "surgical stress," which indicates postoperative physiological and endocrinological internal reaction, and nutritional support for the postoperative patients. Our department is a pioneer in this area in Japan, and we established the Japanese Society for Surgical Metabolism and Nutrition in 1965. In addition, we have been studying endocrine issues, i.e., surgical therapy for breast, thyroid and parathyroid diseases.

Faculties and Students

Professor and Chairman Michio Kaminishi, MD., Ph.D.
(since 1997)
Associate Professor Ken-ichi Mafune, MD., Ph.D.
(Yoshikazu Mimura, M.D., Ph.D.
from Division of Surgical
Operation Center)
Lecturer Shouji Shimoyama, MD., Ph.D.
Toshihisa Ogawa, MD., Ph.D.,
Mitsue Saito MD., Ph.D.,

Associate12
Postdoctor Fellow8
Graduate Student.....9
Secretary4

Past Research and Major Accomplishments

In research on gastrointestinal carcinogenesis, we have established experimental models of gastric carcinogenesis and looked closely at the important roles of repetition of injury and regeneration of gastric mucosa. In particular, we demonstrated that infection of *Helicobacter pylori* acts not only in promotion but also in co-initiation of gastric carcinogenesis. This was the first report in the world to show the direct relationship between H.p. infection and gastric carcinogenesis using experimental models. Furthermore, we verified that duodenogastric reflux and denervation of the gastric mucosa enhance gastric mucosal injury, resulting in development of gastric remnant cancer.

Based on these results, we have adopted new operations for gastric cancer and obtained better results in terms of postoperative QOL and outcome. Our detailed histopathological analysis of colon carcinogenesis revealed de novo carcinogenesis other than adenoma-carcinoma sequence, leading to the current hypothesis of the dysplasia-carcinoma sequence.

In research on surgical metabolism and nutrition, we clearly showed the importance of nutritional support under condition of postoperative hypoxia and endotoxemia. Fatty acids reduced the morbidity and mortality due to panperitonitis, and glutamine attenuated acute lung injury after the organism was challenged with endotoxin. Research on the metabolism of phosphate, calcium and sodium is one of the most important means to clarify the mechanism of the postoperative physiological reaction. We demonstrated the close relationship between these metabolites and catecholamine after surgical stresses such as hypoxia, endotoxemia and ischemic reperfusion injury. These studies aim to reduce the intra- and post-operative stresses that would be risky for patients.

Current Research

The main focus of our current research in the field of Gastrointestinal Surgery is the tailor-made treatment of cancer based on its stage and characteristics. We try to establish the optimal limited surgery for early cancer by application of sentinel node navigation system and molecular analysis of lymph node micrometastasis. For advanced cancer, multimodal therapy combined with extended surgery and perioperative chemotherapy is required. In regard to chemotherapy, a new strategy using apoptosis-related and/or cell differentiation-related agents is likely to achieve better prognosis in advanced cases.

Current research topics in the department of Gastrointestinal Surgery are the followings.

1) Carcinogenesis of gastrointestinal cancer

- Roles of *Helicobacter pylori* infection in gastric carcinogenesis
- Roles of Trefoil Peptides in gastric metaplasia
- Clinical and experimental studies on Barrett esophagus

2) Molecular mechanisms of gastrointestinal cancer

- Effects of hypoxia and nutritional deprivation on cancer development and progression
- Roles of PPAR α in gastric carcinogenesis and treatment of gastric cancer by PPAR α ligands
- Angiogenic factors in gastrointestinal cancer
- Telomerase activity in gastrointestinal tumors
- Lymph node micrometastasis of gastric cancer

3) Minimally invasive treatment of upper GI cancers

- Indication and results of laparoscopic surgery
- Sentinel node navigation surgery for early gastric cancer
- Evaluation of results of PPG and jejunal interposition after gastrectomy in terms of postoperative QOL

4) Multimodal treatment for esophageal and gastric cancers

- Neoadjuvant or definitive chemoradiation therapy for esophageal cancer
- Apoptosis induced by TRAIL
- Prediction of gastric cancer recurrence by molecular analysis of samples of peritoneal washes
- Mechanisms of adverse effects of chemotherapy for gastrointestinal cancer on the intestinal mucosa and its preventive therapy

5) Gastrointestinal motility

- Mechanism of peppermint oil solution on relaxation of digestive tract
- Role of cytokine and COX-2 in gastrointestinal motility
- Effects of intra- and extra-abdominal environments on gastrointestinal motility
- Gastric motility after gastrectomy

The main focus of our current research in the field of Surgical Metabolism and Nutrition is "adaptive response to surgical stresses". In particular, "cross tolerance among different stresses" is a very challenging and important phenomenon to be elucidated, and the clinical application of findings will lead to reduction of morbidity and mortality due to severe surgical stresses and endotoxin shock. On the other hand, there is a definite difference in adaptive response to surgical stress between genders. We have clearly demonstrated the gender difference in cytokine secretion after endotoxin challenge.

In the field of Endocrine Surgery, we have introduced minimally invasive surgery for breast cancer and thyroid tumors through the application of laparoscopic procedures. In terms of differential diagnosis of thyroid tumors, we established a method for the immunohistochemical detection of telomerase reverse transcriptase (hTERT) by in situ hybridization, providing a good marker for distinction between follicular adenoma and follicular cancer.

Current research topics in the department of Surgical Metabolism and Nutrition and Endocrine Surgery are the followings

1) Surgical metabolism and nutrition

- Mechanisms of cross tolerance among different stresses (endotoxin-hypoxia/ hypoxia-endotoxin) after surgery
- Role of catecholamines in adaptation to surgical stress such as endotoxemia
- Bacterial translocation after major surgery and anti-cancer chemotherapy
- Gender difference is a modulation factor for post-operative morbidity
- Parathyroid function after surgical stress
- Ischemic preconditioning and its underlying mechanism (NO, HSP, metallothionein)

2) Endocrine surgery

- Cytology of breast and thyroid tumors by in situ hybridization of telomerase reverse transcriptase (hTERT)
- Effects of preoperative endocrine therapy of breast cancer
- Detection of breast cancer cell in the drainage vein from the breast by using RT-PCR
- Molecular analysis of heterogeneity in breast and thyroid cancers
- Development of QOL questionnaire for breast cancer patients

Future Prospects (Figure 1)

Our main theme in basic and clinical research is "Surgery and Inflammation". There are 2 phases of

inflammation, acute and chronic. Under acute inflammation or acute stress, injured tissue recovers to normal promptly after subsidence of the acute causes. In that case, the organ represses apoptosis and maintains or restores the normal tissue. Many factors such as cytokines, NO, NF- κ B, and HSP play important roles in development and progression of the inflammatory process. Conversely, these molecular factors play a key role in the attenuation of morbidity through across tolerance mechanism. Clinical application of therapy based on cross tolerance leads to a better prognosis for morbid patients after severe surgical stress.

Under chronic inflammation, for, example, In cases of chronic gastritis, however repetition of injury and subsequent regeneration is observed regardless of the causes. The accelerated regeneration of the gastric mucosa induces a newly developed tissue that is adapted for chronic injury by balancing cell proliferation and apoptosis. This phenomenon is widely recognized as metaplasia and all metaplastic change in the human organ is considered to be a result of adaptive reaction. Furthermore, the metaplastic cells and/or the cells departing from the adaptive process have potential for malignant transformation.

The relation between chronic inflammation and carcinogenesis is commonly observed not only in the stomach, but also in the esophagus, colon, liver and other tissues. Examples include reflux esophagitis and Barrett's cancer, ulcerative colitis and colitic cancer, viral hepatitis and hepatoma. Some key factors such

Figure 1. Surgery and Inflammation

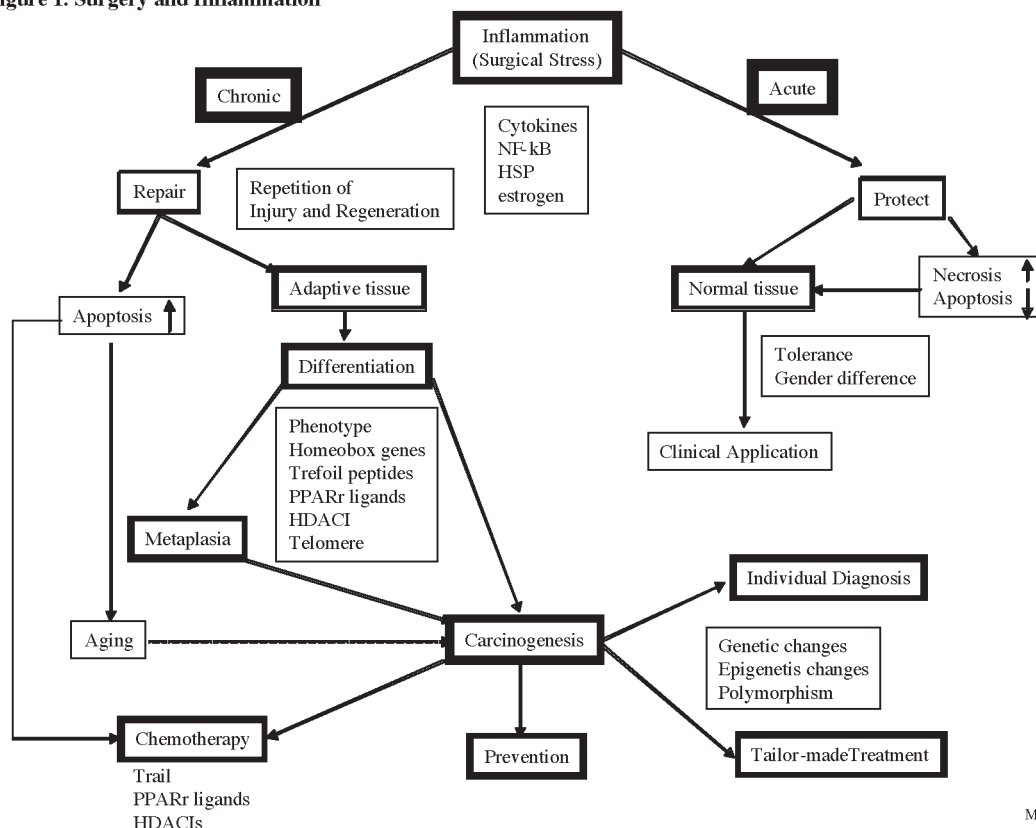

as NF- κ B, COX, NO, PPAR α , HSP, and trefoil peptides play important roles in the process of chronic inflammation. In addition, those factors are also expressed in breast and thyroid tumors.

The development of molecular biology-based diagnosis for cancers and the tailor-made treatment for cancer patients depending on the properties of each cancer and each patient's genetic background, are urgent issues. Further analysis of the relevant factors may contribute to advances in diagnosis, treatment and prevention of not only gastrointestinal cancers but also breast and thyroid cancers. In particular, PPAR α , trefoil peptide and histone deacetylase inhibitors (HDACs) modulate not only cell proliferation but also cell differentiation. We are trying to develop a new strategy of molecular targeting therapy for gastrointestinal, breast and thyroid cancers by application of these cell-differentiating factors.

Research Grants

- Clonal analysis of isolated intestinal metaplastic glands of stomach using X linked polymorphism
- Quantitative detection of micrometastases in the lymph nodes of gastric cancer patients with real-time RT-PCR
- Histopathological change and expression of genes and proteins in chief cells through gastric carcinogenesis in rodent models
- Sublethal endotoxin administration evokes super-resistance to systemic hypoxia.
- Telomeres and telomerase activity in digestive and endocrine organs: Clinical application to the diagnosis and therapy.

Select Publications

1. Kaminishi M, Sadatsuki H, Johjima Y, Oohara T, Kondo Y. A new model for production of chronic gastric ulcer by duodenogastric reflux in rats. *Gastroenterology* 92, 1913-1918,1987.
2. Mimura Y, Yamakawa M, Furuya K, Oohara T. Effect of oxygen supply on protein metabolism in surgically injured rats-oxygen as a nutrient. *Ann Surg* 212,228-233,1990.
3. Maeda J, Dudrick SJ. Rapid spectrophotometric determination of plasma carnitine concentrations. *JPEN* 14, 527-532,1990.
4. Mimiura Y, Khraibi AA, Heublein DM, Knox FG. Acute hypoxia blunts natriuretic and diuretic effects of atrial natriuretic factor in rats. *Am J Physiol* 266, 103-1509,1994.
5. Shimoyama S, Kaminishi M, Joujima Y, Oohara T, Hamada C, Teshigawara W. Lymph node involvement correlation with survival in advanced gastric carcinoma: Univariate and multivariate analysis. *Journal of Surgical Oncology* 57, 164-170,1994.

6. Kaminishi M, Shimizu N, Shimoyama S, Yamaguchi H, Ogawa T, Sakai S, Kuramoto S, Oohara T. Etiology of gastric remnant cancer with special reference to the effects of denervation of the gastric mucosa. *Cancer* 75, 1490-1496,1995.
7. Hiki N, Berger D, Buttenschoen K, Boelke E, Seidelmann M, Strecker W, Kind L, Beger HG. Endotoxemia and specific antibody behavior against different endotoxins following multiple injuries. *J Trauma* 38, 794-801,1995.
8. Kaminishi M, Shimizu N, Nomura S, Ohkura F, Shimoyama S, Yamaguchi H, Hashimoto M, Ogawa T, Sakai S, Oohara T. Different carcinogenesis in the gastric remnant following gastrectomy for gastric cancer. *Cancer* 77, 1646-1653, 1996.
9. Nomura S, Kaminishi M, Sugiyama K, Oohara T, Esumi H. Clonal analysis of isolated single fundic and pyloric gland of stomach using X-linked polymorphism. *Biochem Biophys Res Commun* 226,385-390,1996.
10. Nakamura T, Yamakawa M, Maeda J, Mimura Y, Yamada H, Ogawa T, Kanauchi H, Oohara T. Effect of glutamin on acute lung injury in rats with endotoxemia. *Clinical Nutrition* 16,79-83,1997.
11. Kanauchi H, Mimura Y. Adrenalectomy overcomes the blunted natriuretic response to atrial natriuretic peptide during hypocapnia in rats. *Clin Exp Pharmacol Physiol* 24,850-855,1997.
12. Kuramoto S, Mimura T, Yamazaki K, Kobayashi K, Hashimoto M, Sakai S, Kaminishi M, Oohara T. Flat cancers do develop in the polyp-free large intestine. *Dis Colon Rec* 40,534-542,1997.
13. Shimizu N, Kuramoto S, Mimura T, Kobayashi K, Kobayashi M, Sakai S, Kaminishi M, Oohara T. Helicobacter pylori promotes development of pepsinogen altered pyloric glands, a preneoplastic lesion of glandular stomach. *Cancer Letter* 27, 546-549,1997.
14. Kaminishi M, Yamaguchi H, Shimizu N, Nomura S, Yoshikawa A, Hashimoto M, Sakai S, Oohara T. Stomach-partitioning gastrojejunostomy for unresectable gastric carcinoma. *Arch Surg* 132,184-187,1997.
15. Nomura S, Kaminishi M, Sugiyama K, Oohara T, Esumi H. Clonal analysis of isolated intestinal metaplastic gland of stomach using X-linked polymorphism. *Gut* 42. 663-668, 1997.
16. Hiki N, Beger D, Boelke E, Nussler A, Seidelmann M, Braumueller HD, Oohara T, Beger HG. Endotoxin elimination by human monocytes-endotoxin is neutralized via CD14? *Shock* 7,22-23,1997.
17. Mimura Y, Yamakawa M, Maeda J, Tateno I, Araki S, Fujita T, Sugizaki K, Furuya K, Oohara T. Efficacy of amino acid infusion for improving protein metabolism after surgery-A prospective randomized study in patients undergoing subtotal gastrectomy. *J Am Coll Surg* 185,163-171,1997.
18. Hiki N, Berger D, Boelke CPE, Wiedeck H, Seidelmann M, Staib L, Oohara T, Kaminishi M, Beger HG. Endotoxin binding and elimination by

- monocytes: the secretion of soluble CD14 represents an inducible mechanism counteracting reduced expression of membrane CD14 during sepsis and in a patient with paroxysmal nocturnal hemoglobinuria. *Infect Immun* 66, 1135-1141, 1998.
19. Kanauchi H, Yamasaki K, Ogawa T, Mimura Y. Endoscopic thyroidectomy in a porcine. *Endocrine J* 45,135-136,1998.
 20. Sugiyama A, Maruta F, Ikeno T, Ishida K, Kawasaki S, Katsuyama T, Shimizu N, Tatematsu M. *Helicobacter pylori* infection enhances MNU (N-methyl-N-nitrosourea)-induced stomach carcinogenesis in the Mongolian Gerbil. *Cancer Res* 58, 2067-2069, 1998.
 21. Zhang D, Shimoyama S, Kaminishi M. Feasibility of pylorus-preserving gastrectomy with a wider scope of lymphadenectomy. *Arch Surgery* 133,993-997,1998.
 22. Shimizu N, Inada K, Nakanishi H, Tsukamoto T, Ikehara Y, Kaminishi M, Kuramoto S, Sugiyama A, Katsuyama T, Tatematsu M. *Helicobacter pylori* infection enhances glandular stomach carcinogenesis in Mongolian gerbils treated with chemical carcinogens. *Carcinogenesis* 20, 669-676, 1999.
 23. Shimoyama S, Shimizu N, Kaminishi M. Type-oriented intraoperative and adjuvant chemotherapy and survival after curative resection of advanced gastric cancer. *World J Surg* 23,284-292, 1999.
 24. Shimoyama S, Yamasaki K, Kawahara M, Kaminishi M. Increased angiogenin concentration in colorectal cancer is correlated with cancer progression. *Clinical Cancer Res* 5,1125-1130, 1999.
 25. Mafune K, Tanaka Y. Influence of multimodality therapy on the cellular immunity of patients with esophageal cancer. *Ann Surg Oncol* 7,609-616, 2000.
 26. Nakamura K, Furugori E, Esaki Y, Arai T, Sawabe M, Okayasu I, Fujiwar M, Kammori M, Mafune K, Kato M. Correlation of telomere lengths in normal and cancers tissue in the large bowel. *Cancer Lett* 158,179-184, 2000.
 27. Shimizu N, Ikehara Y, Inaba K, Nakanishi H, Tsukamoto T, Nozaki K, Kaminishi M, Kuramoto S, Sugiyama A, Katsuyama T. Eradication Diminishes Enhancing Effects of *Helicobacter pylori* Infection on Glandular Stomach Carcinogenesis in Mongolian Gerbils. *Cancer Res* 60, 1512-1514, 2000.
 28. Shimoyama S, Kaminishi M. Increased angiogenin expression in gastric cancer correlated with cancer progression. *J Cancer Res Clin Oncol* 126, 468-474, 2000.
 29. Seto Y, Takenoue T, Nariko H, Kaminishi M. Influence of gastrectomy on the distribution of intravenously administered 5-fluorouracil to regional lymph nodes in an animal model. *Cancer* 88,2443-2446, 2000.
 30. Shimoyama S, Aoki F, Murakami T, Toyoda K, Kaminishi M. The feasibility of daily concurrent chemoradiation therapy as a nonsurgical management for esophageal cancer: Our experience and theoretical backgrounds. *J Surg Oncol* 74, 134-137, 2000.
 31. Shimoyama S, Seto Y, Yasuda H, Kaminishi M. Wider indications for the local resection of gastric cancer by adjacent lymphadenectomy. *J Surg Oncol* 75, 157-164, 2000.
 32. Takahashi K, Saito M, Makita M, Tada T, Uchida Y, Yoshimot M, Kasumi F, Akiyama F, Sakamoto G. Surgery for ductal carcinoma in situ. *Breast Cancer* 7,337-340, 2000.
 33. Hiki N, Berger D, Mimura Y, Frick J, Dentener MA, Buurman WA, Seidelmann M, Kaminishi M, Beger HG. Endotoxin binding proteins during major elective surgery: role of sCD14 for phagocytic activation. *World J Surg* 24,499-506, 2000.
 34. Kanauchi H, Mimura Y, Hiki N, Kaminishi M. Catecholamine and cytokine response to laparoscopic adrenalectomy in patients with pheochromocytoma. *Biomed Pharmacother* 54,191-193, 2000.
 35. Kammori M, Takubo K, Nakamura K, Furugori E, Endo H, Kanauchi H, Mimura Y, Kaminishi M. Telomerase activity and telomere length in benign and malignant human thyroid tissues. *Cancer Lett* 159,175-181, 2000.
 36. Ogawa T, Mimura Y, Hiki N, Kanauchi H, Kaminishi M. Ischaemic preconditioning ameliorates functional disturbance and impaired renal perfusion in rat ischaemia-reperused kidneys. *Clin Experimental Pharmacol Physiol* 27,997-1001, 2000.
 37. Ogawa T, Nussler AK, Tuzuner E, Neuhaus P, Kaminishi M, Mimura Y, Beger HG. Contribution of nitric oxide to the protective effects of ischemic preconditioning in ischemia-reperused rat kidneys. *J Lab Clin Med* 138, 50-58, 2001.
 38. Imamura K, Ogura T, Kishimoto A, Kaminishi M, Esumi H. Cell Cycle Regulation via p53 Phosphorylation by a 5'-AMP Activated Protein Kinase Activator, 5-Aminoimidazole-4-Carboxamide-1- β -Ribofuranoside, in a human Hepatocellular Carcinoma Cell Line. *Biochem Biophys Res Commun* 287, 562-567, 2001.
 39. Kammori M, Kanauchi H, Nakamura K, Kawahara M, Weber T, Mafune K, Kaminishi M, Takubo K. Demonstration of human telomerase reverse transcriptase in human colorectal carcinomas by in situ hybridization. *Int J Oncol* 20,15-21, 2001.
 40. Seto Y, Yamaguchi H, Shimoyama S, Shimizu N, Aoki F, Kaminishi M. Results of local resection with regional lymphadenectomy for early gastric cancer. *Am J Surgery* 182, 498-501, 2001.
 41. Kawahara M, Kammori M, Kanauchi H, Noguchi, C, Kuramoto S, Kaminishi M. Immunohistochemical prognostic indicators of gastrointestinal carcinoid tumors. *Eur J Surg Oncol* 28, 140-146, 2001.
 42. Asai K, Hiki N, Mimura Y, Ogawa T, Unou K, Kaminishi M. Gender differences in cytokine secretion by human peripheral blood mononuclear cell:role of estrogen in modulating lps-induced cytokine secretion in an EX VIVO septic model. *Shock* 16, 340-343, 2001.

43. Kammori M, Mafune K, Kawahara M, Mimura Y, Kaminishi M, Takubo K. Telomere shortening with aging in human thyroid and parathyroid tissue. *Experiment Gerontol* 37,513-521, 2002.
44. Kammori M, Nakamura K, Kamnauchi H, Obara T, Kawahara M, Mimura Y, Kaminishi M, Takubo K. Consistent decrease in telomere length in parathyroid tumors but alteration in telomere activity limited to malignancies: Preliminary report. *World J Surg* 26,1083-1087, 2002.
45. Nozaki K, Shimizu N, Tsukamoto T, Inada K, Cao X, Ikehara Y, Kaminishi M, Sugiyama A, Tatematsu M. Reversibility of Heterotopic Proliferative Glands in Glandular Stomach of Helicobacter pylori-infected Mongolian Gerbils on Eradication. *Jpn J Cancer Res* 93,374-381, 2002.
46. Li QL, Ito K, Sakakura C, Fukumachi H, Inoue K, Chi XZ, Kaneda A. Causal relationship between the loss of RUNX3 expression and gastric cancer. *Cell* 109,113-124, 2002.
47. Kaneda A, Kaminishi M, Nakanishi, Y Sugimura T, Ushijima T. Reduced Expression of the Insulin-Induced Protein 1 and p41 ARP2/3 Complex Genes in Human Gastric Cancers. *Int J Cancer* 100, 57-62, 2002.
48. Yamaguchi H, Goldenring JR, Kaminishi M, Lee JR. Identification of Spasmolytic Polypeptide Expressing Metaplasia(SPEM) in Remnant Gastric Cancer and Surveillance Postgastrectomy Biopsies. *Dig Dis Science* 47,573-578, 2002.
49. Shimoyama S, Kaminishi M. Supra-additive antitumor activity of 5FU with tumor necrosis factor related apoptosis inducing ligand on gastric and colon cancers in vitro. *Int J Oncol* 21,643-648, 2002.
50. Yamaguchi H, Goldenring JR, Kaminishi M, Lee JR. Association of spasmolytic polypeptide-expressing metaplasia with carcinogen administration and oxyntic atrophy in rats. *Lab Invest* 82:1045-1052, 2002

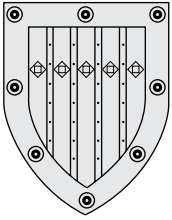

Department of Hepato-Biliary-Pancreatic Surgery / Department of Artificial Organ and Transplantation

Outline and Research Objectives

In September 1893, Professor Sankichi Satoh founded "the Second Department of Surgery, University of Tokyo". He was a pioneer of visceral surgery in Japan and he also founded the Japanese Society of Surgery in 1899. His pupils, professor Waichiroh Okada, professor Keizo Doi, professor Hisashi Ishihara founded departments of otorhinolaryngology, dermatology, and dental surgery, respectively at University of Tokyo Hospital.

In May 1952, professor Seiji Kimoto became the 5th chairman of our department. He was a pioneer of cardiovascular surgery in Japan, and founded the department of thoracic surgery in 1964. In the same year, he also performed the first case of kidney transplantation in Japan.

In July 1971, professor Shigeru Hatano, the 6th chairman, founded the department of Pediatric Surgery.

In April 1994, I (professor Masatoshi Makuuchi) became the 10th chairman. I started living donor liver transplantation on January 31st, 1996 and has done 191 cases by the end of September 2002. As the result of the shift to the Graduate School of Medicine, the three Departments of Surgery were transformed to one Department and 6 divisions in April 1998. Our second Department of Surgery took charge of "Hepato-Biliary-Pancreatic Surgery Division, and Artificial Organ and Transplantation Division".

Our current main research objectives are surgical treatment of hepato-biliary-pancreatic cancer, liver transplantation, and development of artificial liver.

Faculties and Students

Professor and Chairman	Masatoshi Makuuchi, MD, PhD (1994-)
Associate Professors	Norihiro Kokudo, MD Yasuhiko Sugawara, MD
Lecturer	Hiroshi Imamura, MD
Associate	11
Postdoctoral Fellow	5
Graduate student	9
Research student	2
Secretary	4

Past Research and Major Accomplishments

Between late 1970's and early 1980's, I have developed the application of ultrasound to the various treatment modalities of hepatobiliary diseases. First, I have developed the percutaneous transhepatic cholangiography (PTC) and the percutaneous transhepatic biliary drainage (PTBD) method under ultrasound guidance. With these methods, intrahepatic biliary tract was punctured selectively and drained directly by real-time guidance. Ultrasound-guided PTC and

PTBD methods are simple and easy to perform and now are widely used over the world. I also investigated precisely the anatomy and its variation of the intrahepatic portal branches for the first time by the ultrasound examination. Before this work, information on its anatomy was obtained mainly by the study of the cadaveric liver which was somewhat mal understood or by the angiographic studies which by itself does not allow a precise evaluation on each patients. I then developed an intraoperative ultrasound probe and it was facilitated liver surgery for the first time in the world. By its usage, the positional relationship between the tumor and intrahepatic vasculobiliary structure can be understood during the hepatic parenchymal transection. This is particularly important in liver resection in cirrhotic liver because the examination of the tumor by bimanual palpation is difficult in such cases. Further, I developed the method to resect anatomically the Couinaud's segment by the aid of ultrasound and so-called staining technique of the intrahepatic portal branch. This small but anatomical resection is now accepted as a standard procedure for the patients with hepatocellular carcinoma de facto and called also as 'Makuuchi's

procedure'. Based on the findings of the liver anatomy, I have developed and performed, besides the above described anatomical resection, central bisectorectomy or right paramedian sectorectomy. This can be considered a remarkable advance in the era when solely the right or left hepatectomy was performed as anatomical hepatic resections.

Development and application of intermittent hemihepatic or total inflow occlusion technique is also a fruit of my effort in this period. In 1980's, total inflow occlusion was sporadically carried out over the world. But it was used always as a continuous manner and maximum length of the occlusion was considered 60 minutes. Moreover, it was almost a central dogma that the cirrhotic liver could not tolerate the inflow ischemia. Since intermittent ischemia was a recycle of ischemia/reperfusion injury it was believed to be worse than continuous ischemia. In these circumstances, I, for the first time, proved the inflow occlusion can be applied to cirrhotic liver and intermittent inflow occlusion can be applied safely and better than continuous occlusion technique.

The development of various operative procedures preserving the thick short hepatic vein as a drainage vein of right lateral sector and scarifying the right hepatic vein is the achievement of this period. In addition, I first demonstrated the right hepatic vein can be safely divided and ligated extrahepatically if the inferior vena cava ligament was divided and cut prior to the dissection. These vein and ligament are now called as 'Makuuchi's vein' and 'Makuuchi's ligament' worldwide.

Extended right hemihepatectomy is often necessary in the surgical treatment of hilar cholangiocarcinoma. Such a procedure may lead to the increased risk of postoperative liver insufficiency. I have developed and applied the preoperative portal vein embolization (PVE) to induce the atrophy of the liver to be resected and thus induce the compensatory hypertrophy of the liver part to be preserved after the resection. In 1982, I performed the first case of PVE in the world. This method is simple to apply and now is widely applied all over the world.

By virtue of the development of these procedures and improvement in the technical skill, the operative mortality of liver resection in my institute is almost zero including that for the cirrhotic liver and for the hilar cholangiocarcinoma compromised with obstructive jaundice.

In June 1990, I started living donor liver transplantation (LDLT). Based on my own experience of LDLT, I have proposed a formula that allows the calculation of the ideal liver volume to the recipient or the donor used the preoperative decision of what kind of donor hepatectomy should be performed. This formula is now called as 'Makuchi's formula'. In 1993, I per-

formed successfully for the first time in the world the adult-to-adult LDLT using left hemiliver. Following this success, I have carried out adult-to-adult LDLT including emergency transplantation for patients with fulminant hepatic failure. The number of patients undergoing LDLT until now exceeds 200 cases with less than 10 % overall mortality. Recent my contribution to this field is the establishment of the feasibility of the right lateral sector graft and the establishment of the criteria for reconstruction of the middle hepatic venous tributaries in case of right hemiliver graft.

Current Research

I have established a safe and effective hepatic resection techniques based on the liver anatomy and challenged repeated hepatic resections for recurrent liver tumors including hepatocellular carcinoma (HCC) and metastatic tumors. As one of the top institutes of hepato-biliary surgery in the world, we have achieved no mortality and minimum morbidity hepatic resection in recent series of patients, and we have encouraged surgeons worldwide. The accumulated clinical data will reveal the long-term results that demonstrate the advantages of surgical treatment for liver tumors. The molecular biological investigations of liver tumors will elucidate the biological behaviors and prognostic factors of these malignant diseases. However, there are a number of patients with HCC who are not candidates for hepatic resection because of the limited liver functional mass. Since Milan group reported promising results of orthopic liver transplantation for HCC in selected cases, I have started living donor liver transplantation (LDLT) for recurrent HCC. As one of the treatment options for HCC, LDLT will be commonly performed in Japan. The indications for cadaveric liver transplantation for HCC have been limited because of donor shortage. I am trying to expand the indications of LDLT for HCC beyond the Milan criteria. The long-term results may clarify the indications for LDLT for HCC.

Strong and co-workers reported the first successful transplantation from a living donor (LDLT). LDLT is mainly conducted in an attempt to alleviate the shortage of donor organs and to decrease mortality among children awaiting transplants. I started the LDLT program in 1990 when I was in Shinshu University. The indications of LDLT expanded to the adults and I performed the first successful case in 1994. After I moved to University of Tokyo, I started the program in 1996. Until September 2002, I accumulated 191 cases. The mortality rate of the patients is less than 10%, which is much superior to the world standard.

The major limitation for LDLT for adults is the adequacy of the graft size. To overcome this problem, I devised the left liver plus caudate lobe graft with its

venous reconstruction. The caudate lobe can provide about a 7% increase in graft weight, which contributed the less frequent cholestasis after the operation. The right liver graft is now most commonly used graft in LDLT for adults. The right liver graft is usually harvested without the trunk of the middle hepatic vein. However, this type of grafts can cause severe congestion of the right paramedian sector because middle hepatic vein often drains the considerable part of this sector. Middle hepatic vein drainage into the recipient's venous system can be reconstructed using vein grafts. This provides a functioning liver mass comparable to an extended right liver graft. I firstly proposed reconstruction criteria.

Right liver harvesting from living donors is sometimes dangerous when the volume ratio of right liver is large. Some donors have larger right lateral sector compared with left liver. I firstly performed LDLT using this type of graft.

List of On-going Research Projects

1) Hepato-pancreato-biliary surgery

- Extended hemihepatectomy for hilar bile duct carcinoma
- Development of ultrasonic diossector equipped with electrocautery
- Liver resection of liver metastases from GIST
- Long-term evaluation of two-staged pancreaticoduodenectomy
- Intraoperative ultrasound-guided direct pancreatography
- Liver hypertrophy after hepatopancreatoduodenectomy
- Resection of S4inf during hepaticojejunostomy
- Reconstruction of superior mesenteric vein using cryopreserved homograft vein
- Repeated hepatic resection for colorectal metastases
- Risk factors for biliary leakage after liver resection
- Arterial buffer response in cirrhotic patients
- Evaluation of hepatic functional reserve using GSA scintigraphy
- Resection of IVC wall and/or root of hepatic vein in colorectal metastasis
- Effect of cimetidine on the postoperative recurrence in HCC patients
- Disruption of pRb-p16^{INK4} pathway: a common event in ampullary carcinogenesis
- Qualitative and quantitative analysis of des-gamma-carboxy prothrombin (DCP) in cancerous and non-cancerous liver tissue of patients with HCC
- Protein induced by Vitamin K absence or antagonist II absence (PIVKA-II) in cancerous and non-

- cancerous liver tissue of patients with HCC
- Serum anandamide levels in infection

2) Transplantation

- Diagnostic criteria for fungal infection in post-transplant patients
- Quality of life in donors for LDLT
- Argorythms for the timing of liver biopsy after LDLT
- Effect of hANP in post-transplant oliguria
- Serological marker for early detection of carinii pneumonia
- Reconstruction of venous tributaries in right liver graft (long-term outcome)
- Re-evaluation of the Milan's criteria for the indication of cadaveric liver transplantation to patients with hepatocellular carcinoma
- Donor inflow occlusion technique in living donor liver transplantation
- Liver regeneration in donors
- Development of anti-septic biliary drainage tube for LDLT

3) Artificial Organ

- Artificial liver for xeno-cross circulation and clinical application
- Artificial liver and transgenic pig for clinical application
- Development of artificial erythrocyte for liver support system
- Reconstruction of liver tissue using bone marrow transplantation

Future Prospects

Beyond the technical challenges are various medical issues that perhaps need to be given greater attention in the future. LDLT has come to address a health concern of epidemiologic dimension in Japan, namely hepatitis B and C and consequently occurred hepatocellular carcinoma. Recurrent disease after liver transplantation remains a major threat and efforts aimed at prevention and cure have to continue.

Issues related to immunosuppression have to be tackled and induction or facilitation of graft tolerance, which may not be as elusive in LDLT, is yet to be achieved. Management of infection in the immunosuppressed transplant patient is a peculiar challenge that transplant specialists must face in the near future.

Research project of artificial liver device is almost close to clinical use for the bridge to liver transplantation for the patients with liver failure. Recent advance of research about the regeneration medicine has demonstrated the possibility of hepatocyte differenti-

ation from bone marrow or embryonic stem cells. For the treatment of fulminant liver failure, the human hepatocytes cultured and expanded from bone marrow will be used in the future.

Research Grants

- 1999-2001 Improvement of surgical treatment for biliary cancer.
Grant for the prevention of cancer, the ministry of health and labor
4,800,000 yen
- 1999-2001 Artificial liver for xeno-cross circulation and clinical application
Grant from the ministry of education and science (A)(2)
35,800,000yen
- 2000-2001 Clinical improvement and development of organ transplantation
Grant for the human genome and regeneration, the ministry of health and labor
4,500,000 yen
- 2000-2001 Research on intractable liver disease
Grant for intractable diseases, the ministry of health and labor
1,000,000 yen
- 2001-2002 Artificial liver and transgenic pig for clinical application
Grant for advanced medicine (A), the ministry of health and labor
196,840,000 yen

Select Publications

- Makuuchi M, Bandai Y, Ito T, Wada T: Ultrasonically guided pancreatography. *Radiology* 134:767-770, 1980.
- Makuuchi M, Bandai Y, Ito T, Watanabe G, Wada T, Abe H, Muroi T: Ultrasonically guided percutaneous transhepatic bile drainage: A single step procedure without cholangiography. *Radiology* 136:165-169,1980.
- Makuuchi M, Hasegawa H, Yamazaki S, Bandai Y, Watanabe G, Ito T: The inferior right hepatic vein : ultrasonic demonstration. *Radiology* 148:213-217, 1983.
- Makuuchi M, Hasegawa H, Yamazaki S, Moriyama N, Takayasu K, Okazaki M: Primary Budd-Chiari syndrome: ultrasound demonstration. *Radiology* 152:775-779, 1984.
- Makuuchi M, Sukigara M, Mori T, Kobayashi J, Yamazaki S, Hasegawa H, Moriyama N, Takayasu K, Hirohashi S: Bile duct necrosis: complication of transcatheter hepatic arterial embolization. *Radiology* 156:331-334, 1985.
- Makuuchi M, Hasegawa H, Yamazaki S: Ultrasonically guided subsegmentectomy. *Surgery, Gynecology & Obstetrics* 161:346-350, 1985.
- Gunven P, Makuuchi M, Takayasu K, Moriyama N, Yamasaki S, Hasegawa H: Preoperative imaging of

- liver metastases - comparison of angiography CT scan and ultrasonography. *Annals of Surgery* 202:573-579, 1985.
- Makuuchi M, Hasegawa H, Yamazaki S, Takayasu K: Four new hepatectomy procedures for resection of the right hepatic vein and preservation of the inferior right hepatic vein. *Surgery, Gynecology & Obstetrics* 164:68-72, 1987.
 - Makuuchi M, Mori T, Gunvén P, Yamazaki S, Hasegawa H: Safety of hemihepatic vascular occlusion during resection of the liver. *Surgery, Gynecology & Obstetrics* 164:155-158, 1987.
 - Makuuchi M, Hasegawa H, Yamazaki S, Takayasu K, Moriyama N: The use of operative ultrasound as an aid to liver resection in patients with hepatocellular carcinoma. *World Journal of Surgery* 11:615-621, 1987.
 - Sakamoto M, Hirohashi S, Tsuda H, Ino Y, Shimosato Y, Yamazaki S, Makuuchi M, Hasegawa H, Terada M, Hosoda Y: Increasing incidence of hepatocellular carcinoma possibly associated with Non-A, Non-B hepatitis in Japan, disclosed by hepatitis B virus DNA analysis of surgically resected cases. *Cancer Research* 48:7294-7297, 1989.
 - Makuuchi M, Takayama T, Gunven P, Kosuge T, Yamazaki S, Hasegawa H: Restrictive versus liberal blood transfusion policy for hepatectomies in cirrhotic patients. *World Journal of Surgery* 13:644-648, 1989.
 - Makuuchi M, Thai B.L, Takayasu K, Takayama T, Kosuge T, Gunven P, Yamazaki S, Hasegawa H, Ozaki H: Preoperative portal embolization to increase safety of major hepatectomy for hilar bile duct carcinoma: a preliminary report. *Surgery* 107:521-527, 1990.
 - Takayama T, Makuuchi M, Hirohashi S, Sakamoto M, Okazaki N, Takayasu K, Kosuge T, Motoo Y, Yamazaki S, Hasegawa H: Malignant transformation of adenomatous hyperplasia to hepatocellular carcinoma. *Lancet* 33:1153-1155, 1990.
 - Kitahara S, Makuuchi M, Kawasaki S, Ishizone S, Matsunami H, Kamada N, Kawarazaki H, Imanaka T: Lymphoproliferative disorders after FK 506. *Lancet* 337:1234, 1991.
 - Kawasaki S, Makuuchi M, Ishizone S, Matsunami H, Terada M, Kawarazaki H: Liver regeneration in recipients and donors after transplantation. *Lancet* 339:580-581, 1992.
 - Takayasu K, Wakao F, Moriyama N, Muramatsu Y, Yamazaki S, Kosuge T, Takayama T, Okada S, Okazaki N, Makuuchi M: Postresection recurrence of hepatocellular carcinoma treated by arterial embolization: Analysis of prognostic factors. *Hepatology* 16:906-911, 1992.
 - Matsunami H, Makuuchi M, Kawasaki S, Ishizone S, Mizusawa Y, Kawarazaki H, Takayama T: Living-related liver transplantation in fulminant hepatic failure. *Lancet* 340:1411-1412, 1992.
 - Makuuchi M, Kawasaki S, Noguchi T, Hashikura Y, Matsunami H, Hayashi K, Harada H, Kakazu T,

- Takayama T, Kawarazaki H: Donor hepatectomy for living related partial liver transplantation. *Surgery* 113:395-402, 1993.
20. Makuuchi M, Hashikura Y, Kawasaki S, Tan D, Kosuge T, Takayama T: Personal experience of right anterior segmentectomy (segments V and VIII. for hepatic malignancies. *Surgery* 114:52-58, 1993.
 21. Kawasaki S, Makuuchi M, Matsunami H, Hashikura Y, Ikegami T, Chisuwa H, Ikeno T, Noike T, Takayama T, Kawarazaki H: Preoperative measurement of segmental liver volume of donors for living related liver transplantation. *Hepatology* 18:1115-1120, 1993.
 22. Hashikura Y, Makuuchi M, Kawasaki S, Matsunami H, Ikegami T, Nakazawa Y, Kiyosawa K, Ichida T: Successful living-related partial liver transplantation to an adult patient. *Lancet* 343:1233-1234, 1994.
 23. Matsushita K, Kawasaki S, Makuuchi M: Arterial ketone body ratio in liver surgery. *Hepatology* 20:331-335, 1994.
 24. Hui A-M, Kawasaki S, Makuuchi M, Nakayama J, Ikegami T, Miyagawa S: Liver injury following normothermic ischemia in steatotic rat liver. *Hepatology* 20:1287-1293, 1994.
 25. Urata K, Kawasaki S, Matsunami H, Hashikura Y, Ikegami T, Ishizone S, Momose Y, Komiyama A, Makuuchi M: Calculation of child and adult standard liver volume for liver transplantation. *Hepatology* 21:1317-1321, 1995.
 26. Ichida T, Matsunami H, Kawasaki S, Makuuchi M, Harada T, Itoh S, Asakura H: Living related-donor liver transplantation from adult to adult for primary biliary cirrhosis. *Annals of Internal Medicine* 122:275-276, 1995.
 27. Miyagawa S, Kawasaki S, Makuuchi M: Carcinoma between hepatitis B and C viral infection : Tumor multicentricity in cirrhotic liver with hepatic C. *Hepatology* 24:307-310, 1996.
 28. Nagai M, Kubota K, Kawasaki S, Takayama T, Bandai Y, Makuuchi M: Are left-sided gallbladders really located on the left side? *Annals of Surgery* 225:274-280, 1997.
 29. Kubota K, Makuuchi M, Kusaka K, Kobayashi T, Miki K, Hasegawa K, Harihara Y, Takayama T: Measurement of liver volume and hepatic functional reserve as a guide to decision-making in resectional surgery for hepatic tumors. *Hepatology* 26:1176-1181, 1997.
 30. Kawasaki S, Makuuchi M, Matsunami H, Hashikura Y, Ikegami T, Nakazawa Y, Chisuwa H, Terada M, Miyagawa S: Living related liver transplantation in adults. *Annals of Surgery* 227:269-274, 1998.
 31. Abe H, Yamada N, Kamata K, Kumaki T, Shimada M, Osuga J, Shionoiri F, Yahagi N, Kadowaki T, Tamemoto H, Ishibashi S, Yazaki Y, Makuuchi M: Hypertension, hypertriglyceridemia and impaired endothelium-dependent vascular relaxation in mice lacking insulin receptor substrate-1. *Journal of Clinical Investigation* 101:1784-1788, 1998.
 32. Takayama T, Makuuchi M, Hirohashi S, Sakamoto M, Yamamoto J, Shimada K, Kosuge T, Okada S, Takayasu K, Yamazaki S: Early hepatocellular carcinoma as an entity with a high rate of surgical cure. *Hepatology* 28(5) :1241-1246, 1998.
 33. Takayama T, Sekine T, Kondo Y, Kakizoe T, Makuuchi M: Adjuvant adoptive immunotherapy against hepatocellular carcinoma. *Hepatology* 28:1436-1437, 1998.
 34. Hui AM, Cui X, Makuuchi M, Li X, Shi YZ, Takayama T: Decreased p27 (Kip1. expression and cyclin D1 overexpression, alone and in combination, influence recurrence and survival of patients with resectable extrahepatic bile duct carcinoma. *Hepatology* 30:1167-1173, 1999.
 35. Tanaka S, Mori M, Sakamoto Y, Makuuchi M, Sugimachi K, Wands JR: Biologic significance of angiopoietin -2 expression in human hepatocellular carcinoma. *Journal of Clinical Investigation* 1103:341-345, 1999.
 36. Imamura H, Shimada R, Kubota M, Matsuyama Y, Nakayama A, Miyagawa S, Makuuchi M, Kawasaki S: Preoperative portal vein embolization : An audit of 84 patients. *Hepatology* 229:1099-1105, 1999.
 37. Torzilli G, Minagawa M, Takayama T, Inoue K, Hui AM, Kubota K, Ohtomo K, Makuuchi M: Accurate preoperative evaluation of liver mass lesions without fine-needle biopsy. *Hepatology* 330:889-893, 1999.
 38. Kosuge T, Yamamoto J, Shimada K, Yamasaki S, Makuuchi M: Improved surgical results for hilar cholangiocarcinoma with procedures including major hepatic resection. *Annals of Surgery* 230:663-671, 1999.
 39. Sugawara Y, Makuuchi M, Kato N, Shimotohno K, Takada K: Enhancement of hepatitis C virus replication by Epstein-Barr virus-encoded nuclear antigen 1. *The EMBO (European Molecular Biology Organization) Journal* 18: 5755-5760, 1999.
 40. Hui AM, Li X, Shi YZ, Torzilli G, Takayama T, Makuuchi M p27(kip) Expression in normal epithelia, precancerous lesions, and carcinomas of the gallbladder: association with cancer progression and prognosis. *Hepatology* 31:1068-1072, 2000.
 41. Kogure K, Kuwano H, Fujimaki N, Makuuchi M: Relation among portal segmentation, proper hepatic vein, and external notch of the caudate lobe in the human liver. *Annals of Surgery* 231:223-228, 2000.
 42. Minagawa M, Makuuchi M, Torzilli G, Takayama T, Kawasaki S, Kosuge T, Yamamoto J, Imamura H: Extension of the frontiers of surgical indications in the treatment of liver metastases from colorectal cancer. *Annals of Surgery* 231:487-499, 2000.
 43. Miki K, Al-Refaie W, Xu M, Jiang P, Tan Y, Bouret M, Zhao M, Gupta A, Chishima T, Shimada H, Makuuchi M, Moossa AR, Hoffman RM: Methioninase gene therapy of human cancer cells is synergistic with recombinant methioninase treatment. *Cancer Research* 60:2696-2702, 2000.
 44. Takayama T, Sekine T, Makuuchi M, Yamasaki S, Kosuge T, Yamamoto J, Shimada K, Sakamoto M,

- Hirohashi S, Ohashi Y, Kakizoe T: Adoptive immunotherapy to lower postsurgical recurrence rates of hepatocellular carcinoma: a randomised trial. *The Lancet* 356(9232):802-807, 2000.
45. Arii S, Yamaoka Y, Futagawa S, Inoue K, Kobayashi K, Kojiro M, Makuuchi M, Nakamura Y, Okita K, Yamada R, For The Liver Cancer Study Group of Japan: Results of surgical and nonsurgical treatment for small-sized hepatocellular carcinomas : A Retrospective and Nationwide Survey in Japan. *Hepatology* 32:1224-1229, 2000.
 46. Torzilli G, Makuuchi M, Midorikawa Y, Sano K, Inoue K, Takayama T, Kubota K: Liver resection without total vascular exclusion hazardous or beneficial? *Annals of Surgery* 233:167-175, 2001.
 47. Minagawa M, Makuuchi M, Takayama T, Ohtomo K: Selection criteria for hepatectomy in patients with hepatocellular carcinoma and portal vein tumor thrombus. *Annals of Surgery* 233:379-384, 2001.
 48. Saiura A, Sato M, Hirata Y, Nagai R, Makuuchi M: letter to the editor: Cirulating smooth muscle progenitor cells contribute to atherosclerosis. *Nature Medicine* 7(4): 382-383, 2001.
 49. Kubota K, Takayama T, Sano K, Hasegawa K, Aoki T, Sugawara Y, Makuuchi M: Small bile duct reconstruction of the caudate lobe in living-related liver transplantation. *Annals of Surgery* 235(2):174-177, 2002.
 50. Sano K, Makuuchi M, Miki K, Maema A, Sugawara Y, Imamura H, Matsunami H, Takayama T: Evaluation of hepatic venous congestion proposed indication criteria for hepatic vein reconstruction. *Annals of Surgery* 236:241-247, 2002.

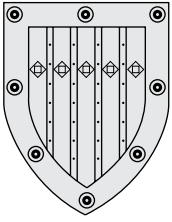

Department of Urology

Outline and Research Objectives

Originally, our department had been attached to Department of Dermatology since 1890, later in 1926, the current department of urology was founded. Initially, urology dealt with urinary tract infection, especially gonorrheal urethritis. Subsequently, its scope has been expanded dramatically and now is covering the diseases of the adrenal gland, the kidney, the urinary tract and the male genital system by means of surgical and non-surgical procedures. Its subspecialty includes pediatric urology, neurourology, female urology, renal transplantation, vascular surgery, endocrine surgery and geriatric urology. For this reason, urology in these days is beyond a section of surgery.

During these progresses, we have been taking national and international leadership in developing and applying the new or minimally invasive treatment modalities. They are exemplified by endoscopic management of the diseases in the upper urinary tract, extracorporeal shock wave lithotripsy (ESWL), laser therapies for prostatic hypertrophy and laparoscopic adrenalectomy or nephrectomy substituting open procedures. Nowadays we are expanding the frontier by introducing less invasive surgeries or more sophisticated treatment modalities to urology. This expansion is supported by incorporating updated cellular and molecular biology to clinical medicine.

Faculties and Students

Professor and Chair	Tadaichi Kitamura, M. D., Ph. D. (1998-)
Associate Professors	Yukio Homma, M. D., Ph. D., Nobutaka Ohta, M. D., Ph. D.
Lecturers	Takumi Takeuchi, M. D., Ph. D., Satoru Takahashi, M. D., Ph. D. Kyoichi Tomita, M. D., Ph. D., Makoto Suzuki, M. D., Ph. D.
Associate	12
Graduate student	11
Research student.....	3
Secretary	5

Past Research and Major Accomplishments

1) Clinical accomplishment

We have been applying endoscopic procedures to clinical practice as less invasive treatment modalities. For example, we are the pioneers of pyeloureteroscopy, by which the upper urinary tract diseases are endoscopically managed.

We have developed new prognostic predictors such as fluorescence in-situ hybridization analysis of exfoliated urothelial cells for bladder cancer recurrence. We examined accuracy of diagnostic procedures for voiding dysfunctions and detected anatomical and electrophysiological abnormalities of the striated urethral sphincter in stress urinary incontinent

women.

As the new treatment modalities, dendritic cell immunotherapy was successfully performed in patients with metastatic renal cell carcinoma. Magnetic stimulation of the sacral roots was developed to improve urinary incontinence.

2) Basic research

In oncology field, we found that hepatocyte growth factor, IL4, Fas ligand or caspase-1 enhanced the invasiveness of renal cell carcinoma, and that anti-apoptotic Bcl-2 proto-oncogene expression increased resistance of human prostatic cancer cells to various apoptotic stimuli. For bladder cancer we detected frequent agreement of genetic alternations (loss of heterozygosity at 10 microsatellite loci and methylation of p16^{INK4} CpG-island) in cancerous mucosa and "normal" bladder mucosa, suggesting morphologically normal epithelium possesses genetic or epigenetic aberrations common with cancer.

In nephrology we produced a knockout mouse model of autosomal dominant polycystic kidney disease (ADPKD) with a targeted deletion of *Pkd1*. Homozygote embryos developed hydrops, cardiac conotruncal defects and renal cystogenesis partly through the E-cadherin-b-catenin-c-MYC pathway and tyrosine phosphorylation of EGFR and Gab1. Maternally-administered pioglitazone, a thiazolidinedione compound, improved survival of knockout embryos, the degree of renal cystogenesis and endothelial dysfunction, suggesting thiazolidine-

diones as a new therapeutic for ADPKD.

Other basic investigations include transplantation research to improve graft survival by expressing IL4 or Fas ligand in the graft, and pharmacologic researches to examine adrenoceptor expression in the prostate or to apply adrenomedullin, a vasorelaxant peptide, to erectile dysfunction and nephron sparing surgery.

3) Investigation in urinary virology

Over these 15 years, we have been investigating the mode of infection in urinary polyomavirus JC virus (JCV) that causes progressive multifocal leukoencephalopathy in immuno-compromized patients. It has long been known since 1970's that JCV is ubiquitous in the human population and infects children asymptotically. However, other characteristics of JCV had not been elucidated further. From our long-run study for about 15 years, many facts have been elucidated. JCV persists and replicates in renal tissue throughout life and is shed frequently into urine after late adolescent and the excretion rate exceeds 60% after around age 50.

The main mode of transmission of JCV is from parents to children through long term cohabitation. During the course of study, we have identified 3 major types of JCV, types A, B and C, according to their DNA sequence variance. A distinct relationship was demonstrated between JCV genotypes and human races. Type A is predominant in Caucasian and type B predominates in Asian, while most Africans have type C, which is verified by phylogenetic tree analysis. Recently Japanese-Americans have shown to reserve their original or Japanese type of JC virus, which supports the hypothesis that JCV is transmitted mostly within the family through long-term cohabitation. As of the end of September in 2002, many urine samples have been collected from across the world more than 50 different countries. In a result, JCV can be classified into at least 12 JCV genotypes that occupy unique domains in the world. Each of 12 JCV genotypes has a special association with distinct human population. Those results have been published in 20 papers of PNAS, J of Virology, Virology, J of Infectious Diseases, and so on.

Current Research

We are more and more concentrating on prostate cancer as the target disease. The expression level of estrogen receptor and its responsive genes are analyzed to further understand molecular mechanisms of responsiveness of prostate cancer cells to estrogens. The expression level of these molecules in human specimens is investigated for predictability of clinical progression of the prostate cancer. Cadherin and its variant forms are also investigated for its predictability

of invasion and metastasis of the prostate cancer, urinary bladder cancer and renal pelvic cancer. Genetic variant of metabolic activation of estramustine phosphate is analyzed for individual patients with hormone refractory prostate cancer to minimize adverse events associated with the agent. Laparoscopic surgery has been established for adrenalectomy, and now being used for prostatectomy, nephrectomy and nephroureterectomy. Treatment for advanced cancer is a challenge in oncology. A new combination chemotherapy regime including paclitaxel and cis-platinum is attempted for metastatic prostate and bladder cancers. Tissue oxidative stress, which is measured by the ratio of reduced-to-total coenzyme Q contents, is now investigated in relation to carcinogenesis, invasion and metastasis of prostate cancer in rats.

Apart from prostate cancer we are developing instruments to measure symptoms and quality of life to assess the efficacy of treatment for voiding dysfunction. As an innovative treatment modality for benign prostatic hyperplasia, high-intensity-focused ultrasound that evaporates prostatic tissue is being applied to reduce the urethral obstruction. Alpha-adrenoceptor is known to mediate tonus of bladder outlet. Knock out mice of the receptors are being investigated for their voiding habits and physiological characteristics of the prostate and bladder. We are exploring genetic abnormality in recurrent stone formers with special interest in genes related to sodium dicarboxylate cotransporter, which transports citrate in renal tubules. For virology we are now examining the offspring of mixed marriages to address the issue of whether JCV has a paternal or maternal bias to its transmission to children. JC virus genotypes in *AINU* people and Antarctic people are analyzed to obtain further information on migration of human-beings in the history..

Future Prospect

Of clinical relevance, improving skills for endoscopic surgeries, especially for laparoscopic procedures are mandatory.

In the field of basic research, tailor-made medicine for advanced prostate cancer will be mainly pursued hereafter, as well as elucidating the pathogenesis of urological malignancies. Besides oncology, clinical and basic research will be performed in the fields of neurogenic bladder, female urology, geriatric urology, urolithiasis, erectile dysfunction and urinary virology.

Research Grants

1. Grant source Grant-in-Aid for Scientific Research (A) from the Ministry of Education, Science, Sports and

- Culture, Japan Research title Application of gene therapy in urologic oncology Principle investigator Tadaichi Kitamura Fund amount 28,800,000 Yen Term 1999-2002
2. Grant source Grant-in-Aid for Scientific Research (C) from the Ministry of Education, Science, Sports and Culture, Japan Research title Prevention of prostate carcinogenesis by suppressing tissue oxidative stress Principle investigator Yukio Homma Fund amount 3,200,000 Yen Term 2001-2004
 3. Grant source Grant-in-Aid for Scientific Research (B) from the Ministry of Education, Science, Sports and Culture, Japan Research title Functional role of adrenoceptor subtype in lower urinary tract obstruction in knockout mice Principle investigator Nobutaka Ohta Fund amount 14,700,000 Yen Term 2001-2002
 4. Grant source Grant-in-Aid for Scientific Research (C) from the Ministry of Education, Science, Sports and Culture, Japan Research title Estrogen receptors and estrogen receptor responsive genes in prostate cancer and benign hyperplasia Principle investigator Satoru Takahashi Fund amount 4,000,000 Yen Term 2002-2003
 5. Grant source Grant-in-Aid for Scientific Research (C) from the Ministry of Education, Science, Sports and Culture, Japan Research title Role of cadherins in invasion and metastasis of prostate cancer Principle investigator Kyoichi Tomita Fund amount 3,600,000 Yen Term 2001-2002

Select Publications

1. Guo J, Sugimoto C, Kitamura T, Ebihara H, Kato A, Guo Z, Liu J, Zheng SP, Wang YL, Na YQ, Suzuki M, Taguchi F and Yogo Y. Four geographically distinct genotypes of JC virus are prevalent in China and Mongolia: implications for the racial composition of modern China. *J. Gen. Virol.* 79, 2499-2505, 1998.
2. Hara K, Sugimoto C, Kitamura T, Aoki N, Taguchi F and Yogo Y. Archetype JC virus efficiently replicates in COS-7 Cells, simian cells constitutively expressing simian virus 40 T antigen. *J. Virol.* 72, 5335-5342, 1998.
3. Homma Y, Gotoh M, Takei M, Kawabe K and Yamaguchi T. Predictability of conventional tests for bladder outlet obstruction assessment in benign prostatic hyperplasia. *Int. J. Urol.* 5, 61-66, 1998.
4. Homma Y, Kawabe K and Hayashi K. Urological morbidity and its influence on global satisfaction with treatment outcome after radical prostatectomy for prostate cancer. *Int. J. Urol.* 5, 556-561, 1998.
5. Kitamura T, Sugimoto C, Ebihara H, Kato A, Guo J, Taguchi F, Tominaga T, Ogawa Y, Ohta N, Kizu N, Imamura K, Funaki H, Kurosawa T, Ichikawa S, Suzuki T, Chiba K, Nagashima K, Yasumoto S and Yogo Y. Peopling of Japan as revealed by genotyping of urinary JC virus DNA. *Anthropol. Sci.* 4, 311-325, 1998.
6. Aoki N, Kitamura T, Tominaga, T, Fukumori N, Sakamoto Y, Kato K and Mori M. Immunohistochemical detection of JC virus in Nontumorous renal tissue of a patient with renal cancer but without progressive multifocal leukoencephalopathy. *J. Clin. Microbiol.* 37, 1165-1167, 1999.
7. Homma Y, Akaza H, Okada K, Yokoyama M, Moriyama N, Usami M, Hirao Y, Tsushima T, Sakamoto A, Ohashi Y, Aso Y and Prostate Cancer Study Group. Early results of radical prostatectomy and adjuvant endocrine therapy for prostate cancer with or without preoperative androgen deprivation. *Int. J. Urol.* 6, 229-237, 1999.
8. Horie S, Aruga S, Kawamata H, Okui N, Kakizoe T and Kitamura T. Biological role of HGF/MET pathway in renal cell carcinoma. *J. Urol.* 161, 990-997, 1999.
9. Kajiwara T, Takeuchi T, Ueki T, Moriyama N, Ueki K, Kakizoe T and Kawabe K. Effect of Bcl-2 overexpression in human prostate cancer cells in vitro and in vivo. *Int. J. Urol.* 6, 520-525, 1999.
10. Nishimatsu H, Takeuchi T, Ueki T, Kajiwara T, Moriyama N, Ishida T, Li B, Kakizoe T and Kitamura T. Fas ligand expression enhances growth of murine renal cell carcinoma in vivo. *Cancer Immunol. Immunother.* 48, 56-61, 1999.
11. Nishimatsu H, Moriyama N, Hamada K, Ukai Y, Yamazaki S, Kameyama S, Konno N, Ishida Y, Ishii Y, Murayama T and Kitamura T. Contractile responses to alpha1- adrenoceptor agonists in isolated human male and female urethra. *BJU Int.* 84, 515-520, 1999.
12. Suzuki M, Hosaka Y, Matsushima H, Goto T, Kitamura T and Kawabe K. Butyrolactone I induced cyclin B1, G2/M arrest, and skipping of mitosis in human prostatic cell Lines. *Cancer Lett.* 57, 121-130, 1999.
13. Takeuchi T, Ueki T, Nishimatsu H, Kajiwara T, Ishida T, Jishage K, Ueda O, Suzuki H, Li B, Moriyama N and Kitamura T. Accelerated rejection of Fas-ligand expressing heart grafts. *J. Immunol.* 162, 518-522, 1999.
14. Aruga S, Wehrli S, Kaissling B, Moe O W, Preisig P A, Pajor A M, and Alpern R J. Chronic metabolic acidosis increases NaDC-1 mRNA and protein abundance in rat kidney. *Kidney Int.* 58, 206-215, 2000.
15. Fujishiro T, Enomoto H, Ugawa Y, Takahashi S, Ueno S and Kitamura T. Magnetic stimulation of the sacral roots in the treatment of stress incontinence: an investigational study and a placebo controlled trial. *J. Urol.* 164, 1277-1279, 2000.
16. Homma Y, Yamaguchi O, Kageyama S, Nishizawa O, Yoshida M and Kawabe K. Nocturia in the adult: Classification on the basis of the largest voided volume and nocturnal urine production. *J. Urol.* 163, 777-781, 2000.
17. Homma Y, Hamada K, Nakayama Y, Tsujimoto G and Kawabe K. Effects of castration on contraction and alpha1-adrenoceptor expression in rat prostate. *Brit. J. Pharmacol.* 131, 1454-1460, 2000.

18. Homma Y, Kondo Y, Takahashi S, Kitamura T and Kawabe K. Reproducibility of cystometry in overactive detrusor. *Eur. Urol.* 38, 681-685, 2000.
19. Kato A, Sugimoto C, Zheng HY, Kitamura T and Yogo Y. Lack of disease-specific amino acid changes in the viral proteins of JC virus isolates from the brain with progressive multifocal leukoencephalopathy. *Arch. Virol.* 145, 2173-2182, 2000.
20. Kume H, Oda H, Nakatsuru Y, Shimizu Y, Takahashi Y, Matsumoto T, Inoue S, Kameyama S, Kitamura T and Ishikawa T. Genetic identification of bilateral primary or metastatic nonpapillary renal cell carcinoma. *BJU Int.* 86, 208-212, 2000.
21. Muto S, Horie S, Takahashi S, Tomita K and Kitamura T. Genetic and epigenetic alteration in normal bladder epithelium in patients with metachronous bladder cancer. *Cancer Res.* 60, 4021-4025, 2000.
22. Takahashi S, Homma Y, Fujishiro T, Hosaka Y, Kitamura T and Kawabe K. Electromyographic study of the striated urethral sphincter in type 3 stress incontinence: evidence of myogenic-dominant damages. *Urology* 56, 946-950, 2000.
23. Takeuchi T, Nishimatsu H, Ueki T, Kajiwara T, Fukuhara H, Ishida T, Moriyama N and Kitamura T. Differentially expressed mRNAs in androgen-independent but not androgen-dependent Shionogi carcinoma. *Urol. Res.* 28, 82-85, 2000.
24. Tomita K, van Bokhoven A, van Leenders GJ, Ruijter ET, Jansen CF, Bussemakers MJ, Schalken JA. Cadherin switching in human prostate cancer progression. *Cancer Res.* 60, 3650-3654, 2000.
25. Tomita K, van Bokhoven A, Jansen CF, Bussemakers MJ and Schalken JA. Coordinate recruitment of E-cadherin and ALCAM to cell-cell contacts by alpha-catenin. *Biochem Biophys. Res. Commun.* 267, 870-874, 2000.
26. Akiyama H, Kurosu T, Sakashita C, Inoue T, Mori S, Ohashi K, Tanikawa S, Sakamaki H, Onozawa Y, Chen Q, Zheng H and Kitamura K. Adenovirus is a key pathogen in hemorrhagic cystitis associated with bone marrow transplantation. *Clin. Infect. Dis.* 32, 1325-1330, 2001.
27. Fukuhara H, Maruyama T, Nomura S, Oshimura M, Kitamura T, Sekiya T and Murakami Y. Functional evidence for the presence of tumor suppressor gene on chromosome 10p15 in human prostate cancers. *Oncogene* 20, 314-319, 2001.
28. Fujimura T, Takahashi S, Urano T, Ogawa S, Ouchi Y, Kitamura T, Muramatsu M and Inoue S. Differential expression of estrogen receptor beta (ERbeta) and its C-terminal truncated splice variant ER betacx as prognostic predictors in human prostatic cancer. *Biochem. Biophys. Res. Commun.* 289, 692-695, 2001.
29. Guo Z, Zheng SP, Sugimoto C, Wang YL, Zheng HY, Takasaka T, Kitamura T, Guo J and Yogo Y. JC virus genotypes in Northwestern China: Implications for its population history. *Anthropol. Sci.* 3, 203-212, 2001.
30. Ishiwata S, Takahashi S, Homma Y, Tanaka Y, Kameyama S, Hosaka Y and Kitamura T. Noninvasive detection and prediction of bladder cancer by fluorescence in situ hybridization analysis of exfoliated urothelial cells in voided urine. *Urology* 57, 811-815, 2001.
31. Kamiyo T, Sato T, Nagatomi Y and Kitamura T. Induction of apoptosis by cyclooxygenase-2 inhibitors in prostate cancer cell lines. *Int. J. Urol.* 8, 35-39, 2001.
32. Kanda H, Kubo K, Hamasaki K, Kanda Y, Nakao A, Kitamura T, Fujita T, Yamamoto K and Mimura T. Influence of various hemodialysis membranes on the plasma (1-3)-beta-D-glucan level. *Kidney Int.* 60, 319-323, 2001.
33. Kuramochi M, Fukuhara H, Nobukuni T, Kanbe T, Maruyama T, Ghosh Hara P, Pletcher M, Isomura M, Onizuka M, Kitamura T, Sekiya T, Reeves RH and Murakami Y. TSLC1 is tumor-suppressor gene in human non-small-cell lung cancer. *Nature Genetics* 27, 427-430, 2001.
34. Kondo Y, Homma Y, Takahashi S, Kitamura T and Kawabe K. Transvaginal ultrasonography of urethral sphincter in continent and incontinent women. *J. Urol.* 165, 149-152, 2001.
35. Nishimatsu H, Suzuki E, Nagata D, Moriyama N, Satonaka H, Walsh K, Sata M, Kangawa K, Matsuo H, Goto A, Kitamura T and Hirata Y. Adrenomedullin induces endothelium-dependent vasorelaxation via the phosphatidylinositol 3-kinase/akt-dependent pathway in rat aorta. *Circul. Res.* 89, 63-70, 2001.
36. Nishimatsu H, Hirata Y, Hayakawa H, Nagata D, Satonaka H, Suzuki E, Horie S, Takeuchi T, Ohta N, Homma Y, Minowada S, Nagai R, Kawabe K and Kitamura T. Effects of intracavernous administration of adrenomedullin on erectile function in rats. *Peptides* 22, 1913-1918, 2001.
37. Ueki T, Takeuchi T, Nishimatsu H, Kajiwara T, Moriyama N, Narita Y, Ueki K and Kitamura T. Silencing of caspase-1 gene occurs in murine and human renal cancer cells and confers solid tumor growth in vivo. *Int. J. Cancer* 91, 673-679, 2001.
38. Yanai Y, Horie S, Yamamoto K, Yamauchi H, Ikegami H, Kurimoto M and Kitamura T. Characterization of the anti-tumor activities of IFN-alfa8 in renal cell carcinoma cells. *J. Interferon Cytokine Res.* 21, 1129-1136, 2001.
39. Azuma T, Horie S, Tomita K, Takahashi T, Tanaka Y, Kashiwase K, Nieda M, Takeuchi T, Ohta N, Shibata Y, Hirai H and Kitamura T. Dendritic cell immunotherapy for patients with metastatic renal cell carcinoma: University of Tokyo experience. *Int. J. Urol.* 9, 340-346, 2002.
40. Fujishiro T, Takahashi S, Enomoto H, Ugawa Y, Ueno S and Kitamura T. Magnetic stimulation of the sacral roots in the treatment of urinary frequency and urge incontinence: an investigational study and a placebo controlled trial. *J. Urol.* 168, 1036-1039, 2002.

41. Homma Y, Yamaguchi T, Kondo Y, Horie S, Takahashi S and Kitamura T. Significance of nocturia in the international prostate symptom score for benign prostatic hyperplasia. *J. Urol.* 167, 172-176, 2002.
42. Homma Y, Ando T, Yoshida M, Kageyama S, Takei M, Kimoto K, Ishizuka O, Gotoh M and Hashimoto T. Voiding and incontinence frequencies - variability of diary data and required diary length. *Neurourol. Urodynam.* 21, 204-209, 2002.
43. Kitamura T, Nishimatsu H, Hamamoto T, Tomita K, Takeuchi T and Ohta N. EMP combination chemotherapy and low-dose monotherapy in advanced prostate cancer. *Expert Rev. Anticancer Ther.* 2, 59-71, 2002.
44. Matsushima H, Kawabe K, Fujime M, Kitamura T, Homma Y, Kishi H, Kawamura T, Umeda, T, Ohishi, Y, Murai M, Kawai T, Yoshida H and Fukuda T. Treatment of patients with superficial bladder cancer by intravesical instillation of anticancer drugs plus oral chemotherapy following TUR- Bt: A randomized controlled trial. *Oncol. Rep.* 9, 283-288, 2002.
45. Muto S, Aiba A, Saito Y, Nakao K, Nakamura K, Tomita K, Kitamura T, Kurabayashi M, Nagai R, Higashihara E, Harris PC, Katsuki M and Horie S. Pioglitazone improves the phenotype and molecular defects of a targeted Pkd1 mutant. *Hum. Mol. Genet.* 15, 1731- 1742, 2002.
46. Nishimatsu H, Hirata Y, Shindo T, Kurihara H, Kakoki M, Nagata D, Hayakawa H, Satonaka H, Sata M, Tojo A, Suzuki E, Kangawa K, Matsuo H, Kitamura T and Nagai R. Role of endogenous adrenomedullin in the regulation of vascular tone and ischemic renal injury: studies on transgenic/knockout mice of adrenomedullin gene. *Circul. Res.* 90, 657-663, 2002.
47. Saruwatari L, Sugimoto C, Kitamura T, Ohno N, Sakai E, Shrestha P, Hoa BK, Phi PTP, An HPH, Tuyet NTA, Honjo T, Kobayashi N, Zheng HY, Takasaka T and Yogo Y. Asian domains of four major genotypes of JC virus, Af2, B1-b, CY and SC. *Arch. Virol.* 147, 1-10, 2002.
48. Sugimoto C, Hasegawa, M, Kato A, Zheng HY, Ebihara H, Taguchi F, Kitamura T, Yogo Y. Evolution of human polyomavirus JC: Implications for the population history of humans. *J.Mol.Evol.* 54, 285-297, 2002.
49. Suzuki M, Zheng H-Y, Takasaka T, Sugimoto C, Kitamura T, Beutler E and Yogo Y. Asian genotypes of JC virus in Japanese-Americans suggests familial transmission. *J. Virol.* 2002, in press.
50. Nishimatsu H, Hirata Y, Shindo T, Kurihara H, Suzuki E, Sata M, Satonaka H, Tanaka R, Nagata D, Kakoki M, Hayakawa H and Nagai R. Epithelial responses of the aorta from adrenomedullin transgenic mice and knock-out mice. *Hypertens. Res.* 2002, in press.

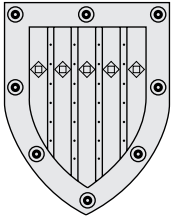

Department of Surgical Oncology

Outline and Research Objectives

The Department of Surgical Oncology was taken over from the First Department of Surgery, which was established in 1893. Dr. Tetsuichiro Muto, who was the ninth Professor of the First Department of Surgery, was appointed as the first Professor of the Department of Surgical Oncology in 1997 based on the introduction of a new system for postgraduate education. Dr. Hirokazu Nagawa was appointed as the second Professor of this department in 1999.

The main research objective in this department is to augment quality of life in patients with malignant disorders by applying knowledge of radiology, molecular biology, cell biology and immunology to clinical setting as well as surgical techniques.

The Department of Surgical Oncology provides comprehensive evaluation, diagnosis, treatment and management for adult patients with both general and oncologic surgical problems, in the ambulatory as well as inpatient setting. Additionally, surgical specialities in the department include the treatment of benign and malignant disorders of the breast and management of malignancies of the gastrointestinal tract (esophageal, gastric, and colorectal). The department is also well known for its innovative therapy for inflammatory bowel disease. Department specialists have expertise in biological cancer immunotherapy, chemotherapy for a variety of malignancies, and radiotherapy for rectal cancer. The department was responsible for 309 inpatients and 18,845 outpatients in the 2000 fiscal year, and 402 inpatients and 16,663 outpatients in the 2001 fiscal year.

Faculties and Students

Professor and Chair	Hirokazu NAGAWA, M.D., Ph.D. (1999-)
Associate Professors	Toshiaki WATANABE, M.D., Ph.D.
Lecturer	Joji KITAYAMA, M.D., Ph.D.
Associate.....	9
Postdoctoral Fellow	5
Graduate Students	16
Research Students.....	7
Secretaries	5

Past Research and Major Accomplishments

1. Preoperative radiotherapy for lower rectal cancer

Preoperative radiation therapy for advanced rectal cancer has been reported to reduce local recurrence in studies in Western countries, but its effectiveness has not yet found wide acceptance in Japan. The reason for this seems to be that although the local recurrence rate is lower in the irradiated group than that in the non-irradiated group in studies in Western countries, the rate shows values around 10% (7.8% to 12.4%), which is almost equal to or somewhat higher than the rate after surgical treatment alone in Japan. This

might be due to the difference between Western countries and Japan in terms of surgical procedure in that the importance of regional lymphadenectomy including lateral node dissection has been emphasized for advanced lower rectal cancer in Japan. Thus, extended lymphadenectomy including lateral node dissection (EXT-L) contributes to a low incidence of local recurrence of lower rectal cancer. However, EXT-L is frequently associated with impairment of sexual and urinary functions. We therefore compared the effectiveness of preoperative radiotherapy with that of EXT-L in a prospective, randomized, controlled study as well as a retrospective analysis. Our studies have suggested that lateral node dissection is not necessary in terms of curability for patients with advanced carcinoma of the lower rectum who undergo preoperative radiotherapy (**reprint numbers 1 and 2**).

Thus, preoperative radiotherapy reduces the rate of local recurrence and improves the chance of survival in patients with resectable, advanced rectal carcinoma. However, because not all tumors respond similarly to radiation, sorting out suitable patients is required to irradiate tumors rationally. Therefore, we investigated the predicting values of radiosensitivity in human rectal carcinoma. Specifically, p53, p21/WAF1 and Ku protein expressions in preradiation

biopsy specimens from patients with primary rectal carcinoma were analyzed immunohistochemically. The proteins of p53 and p21 are those related to cell cycle and apoptosis pathways, and Ku protein is related to the repair of damaged DNA. Our studies have indicated that immunohistochemistry detection of p53, p21 and Ku expressions may be useful parameters for selecting patients with rectal carcinoma for preoperative radiotherapy (reprint numbers 3 and 4).

2. Appropriate application of chemotherapy to patients with colon carcinoma

A combined administration of 5-fluorouracil (5-FU) and leucovorin is regarded as a standard chemotherapy for patients with colon carcinoma. Not all tumors, however, respond similarly to the regimen of chemotherapy. Therefore, we investigated the predicting values of chemosensitivity in patients with colon carcinoma from viewpoints of metabolism and apoptotic effects of 5-FU on the tumors. Specifically, we investigated the effects of thymidylate synthase (TS) and dihydropyrimidine dehydrogenase (DPD) from metabolic aspects and Bcl-2 family from apoptotic aspects on the colon carcinoma. Our studies have indicated that TS is a prognostic factor for colon carcinoma, and that 5-FU adjuvant chemotherapy is appropriate for colon carcinoma with high expression of TS and low expression of DPD (reprint number 5). Our studies have also suggested that the ratio of Bcl-X_L (apoptosis inhibitor) to Bax (apoptosis inducer) is related to chemosensitivity to 5-FU (reprint number 6).

3. Analysis of cell functions from the viewpoint of anti-tumor immunity

Immunotherapy using dendritic cells (DCs) is a modality for cancer patients. We have analyzed characteristics of DCs for the purpose of applying effective DCs to clinical setting. We have demonstrated for the first time the direct activation of human natural killer (NK) cells by DC-NK cell interaction in vitro, suggesting that DCs may have a central role linking the innate and adaptive immune responses. Moreover, in stimulating NK cell function, peripheral blood DCs appear to have a different potential from monocyte-derived DCs. Furthermore, the function of dendritic cells (DCs), antigen-presenting cells that can initiate and regulate cellular and humoral responses, is highly influenced by their level of maturation. Immature DCs may be harmful in anti-tumor immunotherapy, because they can induce immunotolerance rather than immunostimulation. With respect to this issue, we have demonstrated that DC culture in an anti-CD40 monoclonal antibody-immobilized plate in medium supplemented with interferon-gamma has a positive impact on DC maturation and may be optimal for elic-

iting an antigen-specific T-cell response without the need for CD4+ T-helper epitopes (reprint number 7).

Another candidate of effector cells on the anti-tumor immunity is a subset of natural killer (NK) cells in the liver, which are enhanced by alpha-glycosylceramides. Alpha-glycosylceramides induce antitumor immunity in various murine cancer models. Our observations have strongly suggested the potential usefulness of alpha-glycosylceramides for immunotherapy of liver cancer in humans based on their ability to activate CD3-CD56+ NK cells in the liver (reprint number 8).

4. Experimental analysis of hematogenous and lymphatic metastasis on gastrointestinal cancers

We have made efforts to elucidate the mechanism of hematogenous and lymphatic metastasis on gastrointestinal cancers using a flow adhesion system. With respect to hematogenous metastasis, cultured colon cancer cells bound to laminin (LM), but not to fibronectin or vitronectin under the physiological shear condition. Most of the tethered cells did not roll, but arrested immediately and spread within 10-30 min on LM under the continuous presence of shear flow. Our data have suggested that LM can mediate from tethering to spreading of colon cancer cells under the blood flow and plays an essential role in hematogenous metastasis. Our studies have also suggested that E-selectin alone can mediate colon cancer cell lodgment and subsequent metastasis without the contribution of integrin molecules and that the different distribution of E-selectin ligands may affect the adhesion behavior of colon cancer cells in flow conditions (reprint number 9).

With respect to lymphatic metastasis, our studies have indicated high affinity between cancer cells and lymphatic endothelial cells (LEC), and suggested that lymph node metastasis arises from cancer cells adherent to LEC, which can be augmented by an inflammatory stimulus.

5. Projects on upper gastrointestinal tract

Although our study is mainly focused on colorectal cancer, we have also investigated and achieved gastric and esophageal cancers in terms of scientific research as well as surgical techniques. Recently, we identified X-chromosome-linked inhibitor of apoptosis protein (XIAP) and the gene was designated as hRFI, standing for human Ring Finger homologous to IAP type. Northern blot analysis showed that in 70% (14 out of 20) of esophageal cancer patients, expression of hRFI in cancerous regions was two or more times higher than in the corresponding normal tissues (reprint number 10). The other major accomplishment in this field is listed as follows.

1. p21 Waf1/Cip1 expression is a prognostic marker in curatively resected esophageal squamous cell carcinoma, but not p27Kip1, p53, or Rb
2. Local resection with lymphadenectomy for early gastric cancer
3. Quantitative analysis of the cyclin expression in human esophageal cancer cell lines
4. Extended lymph node dissection for gastric cancer cases with N2 lymph node metastasis
5. Microvascular anastomosis for additional blood flow in reconstruction after intrathoracic esophageal carcinoma surgery
6. Prognostic significance of non-gastric malignancy after treatment of early gastric cancer

The relationship of macroscopic shape of superficial esophageal carcinoma to depth of invasion and regional lymph node metastasis.

Current Research

The clinical and academic interests of our department are the upper and lower gastrointestinal tract. We have begun to apply the techniques used in molecular and cellular biology to our research based on the past research and major accomplishment mentioned above. The following are the major themes under research.

1. Cancer therapy targeting to the tumor vessels
2. Immunotherapy with dendritic cells
3. Modulated chemotherapy in association with gene therapy
4. Genetic analysis of colorectal cancer and adenoma
5. Carcinogenesis in superficial early colorectal cancer
6. Prognostic factor of early colorectal cancer
7. Genetic alterations in synchronous and metachronous multiple colorectal cancers
8. Microsatellite instability and a risk of developing multiple colorectal cancers
9. Surveillance program following colectomy for colorectal cancer
10. The mechanism of liver metastasis of colorectal cancer
11. Genetic alterations in ulcerative colitis
12. Association study of candidate genes in ulcerative colitis
13. Carcinogenesis in ulcerative colitis
14. Cancer surveillance in ulcerative colitis
15. Association study of candidate genes in Crohn's disease
16. Angiogenesis inhibition in peritoneal metastasis of gastric cancer

Future Prospects

Research projects described in the past research and the current research are continuously pursued in our department. More specifically, we are interested in cancer therapy targeting angiogenesis resulting from tumor development, immunotherapy with dendritic cells and effective chemotherapy for patients with cancer. We are also interested in investigating what mechanism is involved in metastasis, and how the metastasis is inhibited or suppressed in cancer patients.

It is considered that the need for appropriate clinical and psychological care for outpatients is increasing due to the rising number of patients with intractable malignant diseases. The number of major operations for elderly patients is also increasing. Taking all these trends into account, we need to make greater endeavors in our clinical practice and research in order to meet the demands of today's society.

Research Grant

1. Grant-in-Aid for Scientific Research from the Ministry of Education, Culture, Sports, Science and Technology of Japan, 1997-2001, ¥112,800,000
2. Grant-in-Aid for Scientific Research from the Ministry of Health, Labor and Welfare of Japan, 1997-2001, ¥45,500,000
3. Grant-in-Aid for Scientific Research from the Ministry of Public Management, Home Affairs, Posts and Telecommunications of Japan, 1997-2001, ¥140,600,000

Select Publications (50 papers)

Colorectum

1. Komuro Y, Watanabe T, Hosoi Y, Matsumoto Y, Nakagawa K, Tsuno N, Kazama S, Kitayama J, Suzuki N, Nagawa H. The expression pattern of Ku correlates with tumor radiosensitivity and disease free survival in patients with rectal carcinoma. *Cancer* 95, 1199-1205, 2002.
2. Watanabe T, Tsurita G, Muto T, Sawada T, Sunouchi K, Higuchi Y, Komuro Y, Kanazawa T, Iijima T, Miyaki M, Nagawa H. Extended lymphadenectomy and preoperative radiotherapy for lower rectal cancers. *Surgery* 132, 27-33, 2002.
3. Nagawa H, Muto T, Sunouchi K, Higuchi Y, Tsurita G, Watanabe T, Sawada T. Randomized, controlled trial of lateral node dissection vs. nerve-preserving resection in patients with rectal cancer after preoperative radiotherapy. *Dis Colon Rectum* 44, 1274-1280, 2001.
4. Kyo K, Muto T, Nagawa H, Lathrop GM, Nakamura Y. Association of distinct variants of the intestinal

mucin gene MUC3A with ulcerative colitis and Crohn's disease. *J Hum Genet* 46, 5-20, 2001.

5. Masaki T, Sugiyama M, Atomi Y, Matsuoka H, Abe N, Watanabe T, Nagawa H, Muto T. The indication of local excision for T2 rectal carcinomas. *Am J Surg* 181, 133-7, 2001.
6. Shinozaki M, Watanabe T, Kubota Y, Sawada T, Nagawa H, Muto T: High proliferative activity is associated with dysplasia in ulcerative colitis. *Dis Colon Rectum* 43(Suppl), S34-S39, 2000.
7. Kyo K, Parkes M, Takei Y, Nishimori H, Nagawa H, Baba S, Muto T, Lathrop GM, Nakamura Y. Association of ulcerative colitis with rare VNTR alleles of the human intestinal mucin gene, MUC3. *Human Molecular Genetics* 8, 307-311, 1999.
8. Shinozaki M, Muto T, Suzuki K, Matsuda K, Yokoyama T, Watanabe T, Masaki T, Sato H, Araki S, Nagawa H. Chronic active disease reflects cancer risk in ulcerative colitis. *Jpn J Cancer Res* 90, 1066-1070, 1999.
9. Fu CG, Tominaga O, Nagawa H, Nita ME, Masaki T, Ishimaru G, Higuchi Y, Tsuruo T, Muto T. Role of p53 and p21/WAF1 detection in patient selection for preoperative radiotherapy in rectal cancer patients. *Dis Colon Rectum* 41, 68-74, 1998.
10. Tominaga O, Nita ME, Nagawa H, Muto T. Screening for APC mutation based on detection of truncated APC proteins. *Dig Dis Sci* 43, 306-310, 1998.
11. Muto T, Nagawa H, Watanabe T, Masaki T, Sawada T. Colorectal carcinogenesis. *Dis Colon Rectum* 40(Suppl), S80-S85, 1997.
12. Tominaga O, Nita ME, Nagawa H, Fujii S, Tsuruo T, Muto T. Expression of cell cycle regulators in human colorectal cancer cell lines. *Jpn J Cancer Res* 88, 855-860, 1997.

Chemotherapy

13. Nozawa H, Tsukui H, Nishida K, Yakumar K, Nagawa H, Sekikawa T. Dihydropyrimidine dehydrogenase expression in preoperative biopsy and surgically resected specimens of gastric carcinoma. *Cancer Chemother Pharmacol* 49, 267-73, 2002.
14. Takenoue T, Nagawa H, Matsuda K, Fujii S, Nita ME, Hatano K, Kitayama J, Tsuruo T, Muto T. Relation between thymidylate synthase expression and survival in colon carcinoma, and determination of appropriate application of 5-fluorouracil by immunohistochemical method. *Annals of Surgical Oncology* 7, 193-198, 2000.
15. Nita ME, Ono-Nita SK, Tsuno N, Tominaga O, Takenoue T, Sunami E, Kitayama J, Nakamura Y, Nagawa H. Bcl-X_L antisense sensitizes human colon cancer cell line to 5-fluorouracil. *Jpn J Cancer Res* 91, 825-832, 2000.
16. Saito S, Tsuno N, Nagawa H, Sunami E, Zhengxi J, Osada T, Kitayama J, Shibata Y, Tsuruo T, Muto T. Expression of platelet-derived endothelial cell growth factor correlates with good prognosis in patients with colorectal carcinoma. *Cancer* 88, 42-49, 2000.

17. Seto Y, Nagawa H, Mori M, Tsuruo T, Muto T. Effect of 5-fluorouracil on gastrointestinal carcinogenesis induced by N-methyl-N'-nitro-N-nitrosoguanidine in rats. *Dig Dis Sci* 44, 75-78, 1999.
18. Nita ME, Nagawa H, Tominaga O, Tsuno N, Fujii S, Sasaki S, Fu CG, Takenoue T, Tsuruo T, Muto T. 5-fluorouracil induces apoptosis in human colon cancer cell lines with modulation of Bcl-2 family proteins. *Br J Cancer* 78, 986-992, 1998.
19. Tsai WS, Nagawa H, Muto T. Differential effects of polyunsaturated fatty acids on chemosensitivity of NIH3T3 cells and its transformants. *Int J Cancer* 70, 357-361, 1997.

Immunology

20. Osada T, Nagawa H, Takahashi T, Tsuno NH, Kitayama J, Shibata Y. Dendritic cells cultured in anti-CD40 antibody-immobilized plates elicit a highly efficient peptide-specific T-cell response. *J Immunother* 25, 176-84, 2002.
21. Hasebe H, Sato K, Yanagie H, Takeda Y, Nonaka Y, Takahashi TA, Eriguchi M, Nagawa H. Bcl-2, Bcl-X_L and c-FLIP (L) potentially regulate the susceptibility of human peripheral blood monocyte-derived dendritic cells to cell death at different developmental stages. *Biomed Pharmacother* 56, 144-51, 2002.
22. Osada T, Nagawa H, Kitayama J, Tsuno NH, Ishihara S, Takamizawa M, Shibata Y. Peripheral Blood Dendritic Cells, but Not Monocyte-Derived Dendritic Cells, Can Augment Human NK Cell Function. *Cellular Immunology* 213, 14-23, 2001.
23. Nakayama H, Kitayama J, Muto T, Nagawa H. Characterization of intracellular cytokine profile of CD4(+) T cells in peripheral blood and tumor-draining lymph nodes of patients with gastrointestinal cancer. *Jpn J of Clin Oncology* 30, 301-305, 2000.
24. Kitayama J, Hidemura A, Saito H, Nagawa H. Shear stress affects migration behaviour of polymorphonuclear cells arrested on endothelium. *Cell Immunology* 203, 39-46, 2000.
25. Kitayama J, Ikeda S, Kumagai K, Saito H, Nagawa H. Alpha-6-beta-1 integrin (VLA-6) mediates leukocytes tether and arrest on laminin under physiological shear flow. *Cell Immunology* 199, 97-103, 2000.
26. Ishihara S, Nieda M, Kitayama J, Osada T, Yabe T, Kikuchi A, Koezuka Y, Porcelli SA, Tadokoro K, Nagawa H, Juji T. Alpha-glycosylceramides enhance the antitumor cytotoxicity of hepatic lymphocytes obtained from cancer patients by activating CD3-CD56+ NK cells in vitro. *J Immunol* 165, 1659-1664, 2000.
27. Ishihara S, Nieda M, Kitayama J, Osada T, Yabe T, Ishikawa Y, Nagawa H, Muto T, Juji T. CD8+NKR-P1A+ T cells preferentially accumulate in human liver. *Eur J Immunol* 29, 2406-2413, 1999.

Metastasis

28. Nakayama H, Kitayama J, Nagawa H. Rat gastric adenocarcinoma cell line BV9 avidly adheres to lymphat-

- ic endothelium under lymphatic flow condition. *J Exp Clin Cancer Res* 21, 289-94, 2002.
29. Yano H, Kitayama J, Hatano K, Tsuno N, Osada T, Watanabe T, Tsuruo T, Muto T, Nagawa H. Clustered cancer cells show a distinct adhesion behavior from single cell form under physiological shear conditions. *J Exp Clin Cancer Res* 20, 407-12, 2001.
 30. Sunami E, Tsuno N, Osada T, Saito S, Kitayama J, Tomozawa S, Tsuruno T, Shibata Y, Muto T, Nagawa H. MMP-1 is a prognostic marker for hematogenous metastasis of colorectal cancer. *Oncologist* 5, 108-114, 2000.
 31. Kitayama J, Tsuno N, Sunami E, Osada T, Muto T, Nagawa H. E-selectin can mediate the arrest type of adhesion of colon cancer cells under physiological shear flow. *Eur J Cancer* 36, 121-127, 2000.
 32. Tomozawa S, Nagawa H, Tsuno N, Hatano K, Osada T, Kitayama J, Sunami E, Nita ME, Ishihara S, Yano H, Tsuruo T, Shibata Y, Muto T. Inhibition of haematogenous metastasis of colon cancer in mice by a selective COX-2 inhibitor, JTE-522. *Br J Cancer* 81, 1274-1279, 1999.
 33. Kitayama J, Nagawa H, Tsuno N, Osada T, Hatano K, Sunami E, Saito H, Muto T. Laminin mediates tethering and spreading of colon cancer cells in physiological shear flow. *Br J Cancer* 80, 1927-1934, 1999.
 34. Maeda M, Nagawa H, Maeda T, Koike H, Kasai H. Alcohol consumption enhances liver metastasis in colorectal carcinoma patients. *Cancer* 83, 1483-1488, 1998.
- Molecular biology**
35. Sasaki S, Nakamura T, Arakawa H, Mori M, Watanabe T, Nagawa H, Croce CM. Isolation and characterization of a novel gene, hRFI, preferentially expressed in esophageal cancer. *Oncogene*, 21, 5024-30, 2002.
 36. Uchida H, Shinoura N, Kitayama J, Watanabe T, Nagawa H, Hamada H. Caspase-8 gene transduction augments radiation-induced apoptosis in DLD-1 cells. *Biochem Biophys Res Commun* 292, 347-54, 2002.
 37. Kazama S, Ajioka Y, Watanabe H, Watanabe T, Nagawa H. Not infrequent K-ras mutations in depressed-type early colorectal carcinomas larger than 10 mm. *Jpn J Cancer Res* 93, 178-83, 2002.
 38. Kato M, Yano K, Matsuo F, Saito H, Katagiri T, Kurumizaka H, Yoshimoto M, Kasumi F, Akiyama F, Sakamoto G, Nagawa H, Nakamura Y, Miki Y. Identification of Rad51 alteration in patients with bilateral breast cancer. *J Hum Genet* 45, 133-137, 2000.
 39. Umetani N, Sasaki S, Watanabe T, Ishigami H, Ueda E, Nagawa H. Diagnostic primer sets for microsatellite instability optimized for a minimal amount of damaged DNA from colorectal tissue samples. *Annals Surg Oncol* 7, 276-280, 2000.
 40. Ishiguro T, Nagawa H, Naito M, Tsuruo T. Analysis of novel metastasis-associated gene TI-227. *Jpn J Cancer Res* 91, 390-394, 2000.
- Stomach and esophagus**
41. Ishiguro T, Ishiguro C, Ishiguro G, Nagawa H. Midazolam sedation for upper gastrointestinal endoscopy: comparison between the states of patients in partial and complete amnesia. *Hepatogastroenterology* 49, 438-40, 2002.
 42. Nita ME, Nagawa H, Tominaga O, Tsuno N, Hatano K, Kitayama J, Tsuruo T, Domene CE, Muto T. p21 Waf1/Cip1 expression is a prognostic marker in curatively resected esophageal squamous cell carcinoma, but not p27Kip1, p53, or Rb. *Annals Surg Oncol* 6, 481-488, 1999.
 43. Seto Y, Nagawa H, Muto Y, Kaizaki S, Kitayama J, Muto T. Preliminary report on local resection with lymphadenectomy for early gastric cancer. *Br J Surg* 86, 526-528, 1999.
 44. Fujii S, Tominaga O, Nagawa H, Tsuno N, Nita ME, Tsuruo T, Muto T. Quantative analysis of the cyclin expression in human esophageal cancer cell lines. *J Exp Clin Cancer Res* 17, 491-496, 1998.
 45. Seto Y, Nagawa H, Muto T. Results of extended lymph node dissection for gastric cancer cases with N2 lymph node metastasis. *Int Surg* 82, 257-261, 1997.
 46. Nagawa H, Seto Y, Kobori O, Muto T. An experience of treatment for patients with thoracic esophageal cancer invading adjacent organs. *Jpn J Clin Oncol* 27, 248-250, 1997.
 47. Nagawa H, Seto Y, Muto T. Recent advances in gastric cancer. *Digestion* 58(Suppl 1), 62-64, 1997.
 48. Nagawa H, Seto Y, Nakatsuka T, Kaizaki S, Muto T. Microvascular anastomosis for additional blood flow in reconstruction after intrathoracic esophageal carcinoma surgery. *Am J Surg* 173, 131-133, 1997.
 49. Seto Y, Nagawa H, Muto T. Prognostic significance of non-gastric malignancy after treatment of early gastric cancer. *Br J Surg* 84, 418-421, 1997.
 50. Seto Y, Nagawa H, Muto T. Impact of lymph node metastasis on survival in early gastric cancer. *World J Surg* 21, 186-190, 1997.

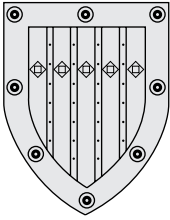

Department of Dermatology

Outline and Research Objectives

Department of Dermatology has been chaired by Kunihiko Tamaki M.D.Ph.D. since 1994. The Department of Dermatology celebrated its 100th anniversary in 1990. Originally it was founded as the Department of Dermatology and Urology, which also encompassed venereology. In 1946 the Department of Dermatology was separated from that of Urology. Department of Dermatology had its branch department in Branch Hospital for about 50 years until these two departments joined last year. A professor, two associate professors, four lecturers and nine associates take part in in-patient and out-patient cares as well as research and teaching activities. We usually have around 10 residents and 8 students of doctoral Ph.D. course. Thirty doctors who basically belong to our department are currently out in affiliated hospitals mainly engaged in clinical works there. Additionally there are four staff members abroad in the US and involved in advanced research activities in cell biology and molecular biology as postdoctoral fellow.

We have specialized out-patient clinic in which some of doctors who are in affiliated hospitals also participate and each specialized service reflects its own research field in a disease oriented manner.

Of course these specialized groups performing their clinical and research activities are not exclusive, and there are increasing communications in our department as well as with other departments. Specialized out-patient clinic include the following; atopic dermatitis, psoriasis, collagen diseases including systemic sclerosis, SLE and dermatomyositis, skin surgery and laser surgery including malignant melanoma, squamous cell carcinoma and basal cell carcinoma, and infection especially fungal infection. These clinical groups are divided into three main research groups;

1) Immunology and allergology group, 2) collagen disease group and 3) skin surgery group. Immunology and allergology group engaged in atopic dermatitis and psoriasis clinic and focuses on Langerhans cell and keratinocyte biology research including cytokine and chemokine. Collagen group engaged in collagen disease clinic and focuses mechanisms TGF- β and collagen. Skin surgery group engaged in skin surgery and laser surgery clinic and focuses of tumor growth, metastasis, fibrosis and dermatoscopic clinical study. Research groups are maintained by associate professor or lecturer. These senior investigators have ten to fifteen year experience as dermatologist and more than seven year experience of research in Japan as well as in U.S.A. They have one to three associates and students of Ph.D. course to extend their research. Professors participate and understand the research activities in this department through conferences which are usually held once to twice a month by each research group.

Faculties and Students

Professor and Chairman	Kunihiko Tamaki M.D. Ph.D.(1994-)
Associate Professors	Kanako Kikuchi M.D. Ph.D. Akihiko Asahina M.D. Ph.D.
Lecturer	Mayumi Komine M.D. Ph.D. Hironobu Ihn M.D. Ph.D. Hidehisa Saeki M.D. Ph.D. Takahiro Watanabe M.D. Ph.D.
Associate	9
Graduate student	8
Secretary	3

Past Research and Major Accomplishments

1) Immunology and allergology group:

We established a method to purify murine Langerhans cells (LC), which comprise from one to three percentage of epidermal cells, over 95% purity in each experiment and conducted a series of experiments. We found that murine LC produced IL-12 which is a key cytokine for Th1 induction and that IL-12 production was inhibited by GM-CSF and enhanced by TGF- β 1. Furthermore we found prion-related protein was expressed in LC as well as ker-

atinocytes. Prion-related protein is maintained on LC after culture suggesting its participation of LC in peripheral inoculation of prion disease. With regards to atopic dermatitis (AD) we found that lesional skin of NC/Nga mice, which exhibit AD like skin lesion, shows enhanced expression of Th2 chemokine TARC/CCL17 and MDC/ CCL22 and their receptor CCR4. We extended this to human AD and other skin diseases such as bullous pemphigoid, an autoimmune blistering disease and mycosis fungoides, cutaneous T cell lymphoma, all exhibit hypereosinophilia and high serum IgE and found that TARC, MDC and CCR4 are involved in these diseases.

2) Collagen disease group:

TGF- β has been implicated in the pathogenesis of fibrosis. In collaboration with skin surgery group we showed upregulated expression of TGF- β receptors in lesional skin of fibrosis such as systemic sclerosis and localized scleroderma and that upregulated expression of TGF- β receptors is implicated in fibrosis. Fibroblast proliferation is also important in fibrosis as well as wound healing. We demonstrated that fibroblast proliferation is mediated via extracellular signal related kinase (ERK)-dependent pathway. We also studied the expression of tissue inhibitor of metalloproteinases (TIMPs) and showed that TIMP2 was upregulated by IL-4 via p-38 mitogen-activated protein kinase dependent pathway. With regards to clinical research we investigated the prevalence and clinical significance of various autoantibodies in collagen diseases. We also studied the levels of various cytokines and adhesion molecules and their significance.

3) Skin surgery group:

We investigated progressive and metastatic factors in malignant melanoma and other skin tumors. We found dysregulated expression of TGF- β and its receptor in basal cell carcinoma and also found that pattern of basal cell keratin 14 expression is a possible marker for tumor progression in Bowen's disease. We also reported TIMP-1 and TIMP-2 differently regulate the growth of human melanoma cell lines. With regards to clinical research we established criteria for the diagnosis of pigmented plantar nevi which is useful to differentiate pigmented nevi from early acral lentiginous melanoma. We also proposed criteria to differentiate Hutchinson's sign seen in malignant melanoma from subungual nevus.

Current Research

1) Immunology and allergology group:

Using the TGF- β primed LC we are trying to induce Th1 instead of Th2. We succeeded in inducing

Th1 in vitro and trying to induce Th1 in vivo. We continue to characterize murine LC and found LC express Toll-like receptor (TLR)-2 3 4 and 9. We are trying to induce Th1 using these receptors. From the results of mouse and human study we are trying to establish K14-TARC transgenic mice to further characterize the significance of TARC expression in the epidermis. With regards to clinical research we are analyzing gene polymorphism of AD and proriasis such as Eotaxin, TARC, IL-13 and IL-12. We are also investigating the CTACK/CCL27 expression of AD and psoriasis. We are analyzing the human peripheral blood dendritic cells (DC) for the expression of cutaneous lymphocyte associated antigen (CLA), fucosyltransferase VII, CCR4 and CCR10, and their function.

2) Collagen disease group:

We are studying the interaction of transcription factors Sp 1, Smad 3 and p300/CBP and the significance of these transcriptional factors in TGF- β induced collagen gene upregulation. PKC is important in collagen accumulation, thus we are studying the regulation of collagen deposition by PKC especially PKC α and PKC δ . The regulation of TGF- β receptors by various cytokines such as EGF and TNF- α are now being studied. We found overexpression of α V β 5 and β 3 integrin on fibroblasts from fibrotic tissue. The function of this is under investigation using stable transfectants of integrins. We also are studying the regulation of tenascin gene expression by IL-13, PDGF and TGF- β .

3) Skin surgery group:

We are now trying to establish the significance of sentinel lymph node biopsy in the clinic and trying to find the metastatic factors in malignant melanoma. We are analyzing chemokine and chemokine receptor expression of primary and metastatic melanoma. We also are studying the effect of narrow band UVB on human melanocytes in order to understand the enhanced pigmentation seen in patients receiving narrow band UVB therapy.

Future Prospects

Immunology and allergology group: We will continue the murine LC study to further clarify the characteristics of LC and their participation in skin diseases. We will also study the possibility to use LC for therapy as well as DC from human peripheral blood. We will try to find novel gene products using purified LC and analyze their function. We will establish other transgenic mice such as K-14- CTACK to further analyze the participation of chemokine in skin diseases. With regards to clinical research we will further examine other cytokine and chemokine in skin dis-

eases such as AD and psoriasis and try to use their antagonist for therapy.

Collagen disease group: To further analyze the molecular mechanisms of TGF- β induced collagen gene expression, the cross talk of PI3 kinase and Smad pathway will be determined. Significance of integrin expression in fibrosis will be determined. The mechanisms of EGF and FK506 on the expression of collagen gene expression will be studied in conjunction with the therapeutic approach.

Skin surgery group: DC therapy for malignant tumors using DC from peripheral blood and skin resident LC will be investigated. We will also analyze chemokine / chemokine receptor expression in growth and metastasis of skin tumors.

Research Grants from

1. The Ministry of Education, Science and Culture (A,2002-2005)
"Study on the dendritic cells and chemokine in the pathogenesis of skin diseases"
2. The Health Science Research Grants from the Ministry of Health, Welfare and Labor (2002-)
"Study to identify organ specific molecules in the pathogenesis of skin diseases"
3. The Health Science Research Grants from the Ministry of Health, Welfare and Labor (2001-2002)
"Basic Research for Atopic Dermatitis using Dendritic cells as a tool"
4. The Ministry of Education, Science and Culture (B, 1157063 1999-2000)
"The study of skin specific T cells in the pathogenesis of skin diseases"
5. The Ministry of Education, Science and Culture (B,11470179,1999-2001)
"The study to establish Langerhans cell cell line and its use for treatment"

Select Publications

1. Kakinuma T, Wakugawa M, Nakamura K, Hino H, Matsushima K, Tamaki K. High level of TARC (thymus and activation-regulated chemokine/CCL17) in blister fluid and sera of patients with bullous pemphigoid. *Br J Dermatol*, in press.
2. Sugaya M, Nakamura K, Watanabe T, Asahina A, Yasaka N, Koyama Y, et al: Expression of cellular prion-related protein by murine Langerhans cells and keratinocytes. *Journal of Dermatology Sci*. 28:126-134,2002
3. Hattori N, Komine M, Yano S, Kaneko T, Hanakawa Y, Hashimoto K, Tamaki K.: Interferon-g, a strong suppressor of cell proliferation, induces upregulation of keratin K6, one of the inflammatory- and proliferation-associated keratins. *J Invest Dermatol* 119: 403-10, 2002.
4. Kakinuma T, Nakamura K, Wakugawa M, Mitsui H, Tada Y, Saeki H, Torii H, Komine M, Asahina A,

Tamaki K. Serum macrophage-derived chemokine (MDC) levels are closely related with the disease activity of atopic dermatitis. *Clin Exp Immunol*. 127: 270-3, 2002.

5. Ihn H, Yamane K, Asano Y, Kubo M, Tamaki K. IL-4 upregulates the tissue inhibitor of metalloproteinase-2 in dermal fibroblasts via the p38 mitogen-activated protein kinase-dependent pathway. *J Immunol* 168: 1895-902, 2002.
6. Tamaki K, Nakamura K: The role of lymphocyte in healthy and eczematous skin. *Curr Opinion Allergy Clin. Immunol* 1:455-60,2001
7. Kubo M, Ihn H, Yamane K, Asano Y, Jinnin M, Tamaki K: Differential expression of transforming growth factor-beta receptors in squamous cell carcinoma. *Br J Dermatol*. 145: 840-2, 2001
8. Kubo M, Ihn H, Kuwana M, Yamane K, Yazawa N, Tamaki K: Prevalence in myositis of antibodies recognizing anti-U3 RNA probably in a novel complex with 22/25 kD protein and not fibrillar. *Clin Exp Immunol*. 126: 339-44, 2001
9. Yazawa N, Ihn H, Yamane K, Kubo M, Fujimoto M, Kikuchi K, Soma Y, Tamaki K: Elevated circulating soluble CD30 levels in patients with polymyositis/dermatomyositis. *Br J Dermatol*. 145: 676-8, 2001
10. Hoashi T, Kadono T, Kikuchi K, Etoh T, Tamaki K: Differential growth regulation in human melanoma cell lines by TIMP-1 and TIMP-2. *Biochem Biophys Res Commun*. 288: 371-9, 2001
11. Komine M, Okinaga M, Takeda F, Nashiro K, Kikuchi K, Murakami T, Soma Y, Tamaki K: Patterns of basal cell keratin 14 expression in Bowen's disease: a possible marker for tumour progression. *Br J Dermatol*. 145: 223-8, 2001
12. Wakugawa M, Nakamura K, Kakinuma T, Onai N, Matsushima K, Tamaki K: CC chemokine receptor 4 expression on peripheral blood CD4+ T cells reflects disease activity of atopic dermatitis. *J Invest Dermatol*. 117: 188-96, 2001
13. Tamaki K, Sugaya M, Tada Y, Uasaka N, Uehira M, Nishimoto H, Nakamura K: Epidermal and dermal gamma-delta T cells. *Chem Immunol* 79:43-51,2001
14. Asano Y, Ihn H, Yamane K, Yazawa N, Kubo M, Fujimoto M, Tamaki K: Clinical significance of surfactant protein D as a serum marker for evaluating pulmonary fibrosis in patients with systemic sclerosis. *Arthritis Rheum*. 44: 1363-9, 2001
15. Asahina A, Tada Y, Nakamura K, Tamaki K: Griseofulvin has a potential to modulate the expression of cell adhesion molecules on leukocytes and vascular endothelial cells. *Int Immunopharmacol*. 1: 75-83, 2001
16. Kubo M, Ihn H, Yamane K, Tamaki K: Up-regulated expression of transforming growth factor beta receptors in dermal fibroblasts in skin sections from patients with localized scleroderma. *Arthritis Rheum*. 44: 731-4, 2001
17. Tada Y, Asahina A, Nakamura K, Miyazono K, Tomura M, Fujiwara H, Tamaki K: Transforming

- growth factor-beta up-regulates CD40-engaged IL-12 production of mouse Langerhans cells. *Eur J Immunol.* 31: 294-300, 2001
18. Kakinuma T. Nakamura K. Wakugawa M. Mitsui H. Tada Y. Saeki H. Torii H. Asahina A. Onai N. Matsushima K. Tamaki K: Thymus and activation-regulated chemokine in atopic dermatitis: Serum thymus and activation-regulated chemokine level is closely related with disease activity. *J Allergy Clin Immunol.* 107: 535-41, 2001
 19. Yazawa N. Ihn H. Yamane K. Etoh T. Tamaki K: The successful treatment of prurigo pigmentosa with macrolide antibiotics. *Dermatology.* 202: 67-9, 2001
 20. Ihn H. Yamane K. Kubo M. Tamaki K: Blockade of endogenous transforming growth factor beta signaling prevents up-regulated collagen synthesis in scleroderma fibroblasts: association with increased expression of transforming growth factor beta receptors. *Arthritis Rheum.* 44: 474-80, 2001
 21. Kawabata Y. Ohara K. Hino H. Tamaki K: Two kinds of Hutchinson's sign, benign and malignant. *J Am Acad Dermatol.* 44: 305-7, 2001
 22. Wakugawa M. Hayashi K. Nakamura K. Tamaki K: Evaluation of mite allergen-induced Th1 and Th2 cytokine secretion of peripheral blood mononuclear cells from atopic dermatitis patients: association between IL-13 and mite-specific IgE levels. *J Dermatol Sci.* 25: 116-26, 2001
 23. Asahina A. Tada Y. Nakamura K. Tamaki K: Colchicine and griseofulvin inhibit VCAM-1 expression on human vascular endothelial cells - evidence for the association of VCAM-1 expression with microtubules. *J Dermatol Sci.* 25: 1-9, 2001
 24. Watanabe T. Nakamura K. Wakugawa M. Kato A. Nagai Y. Shioda T. Iwamoto A. Tamaki K: Antibodies to molluscum contagiosum virus in the general population and susceptible patients. *Arch Dermatol.* 136: 1518-22, 2000
 25. Ihn H. Tamaki K: Increased phosphorylation of transcription factor Sp1 in scleroderma fibroblasts: association with increased expression of the type I collagen gene. *Arthritis Rheum.* 43: 2240-7, 2000
 26. Ihn H. Tamaki K: Oncostatin M stimulates the growth of dermal fibroblasts via a mitogen-activated protein kinase-dependent pathway. *J Immunol.* 165: 2149-55, 2000
 27. Wakugawa M. Nakamura K. Hino H. Toyama K. Hattori N. Okochi H. Yamada H. Hirai K. Tamaki K. Furue M: Elevated levels of eotaxin and interleukin-5 in blister fluid of bullous pemphigoid: correlation with tissue eosinophilia. *Br J Dermatol.* 143: 112-6, 2000
 28. Nakamura K. Imakado S. Takizawa M. Adachi M. Sugaya M. Wakugawa M. Asahina A. Tamaki K: Exacerbation of pustulosis palmaris et plantaris after topical application of metals accompanied by elevated levels of leukotriene B4 in pustules. *J Am Acad Dermatol.* 42: 1021-5, 2000
 29. Ihn H. Tamaki K: Competition analysis of the human alpha2(I) collagen promoter using synthetic oligonucleotides. *J Invest Dermatol.* 114: 1011-6, 2000
 30. Tada Y. Asahina A. Nakamura K. Tomura M. Fujiwara H. Tamaki K: Granulocyte/macrophage colony-stimulating factor inhibits IL-12 production of mouse Langerhans cells. *J Immunol.* 164: 5113-9, 2000
 31. Ihn H. Sato S. Fujimoto M. Igarashi A. Yazawa N. Kubo M. Kikuchi K. Takehara K. Tamaki K: Characterization of autoantibodies to endothelial cells in systemic sclerosis (SSc): association with pulmonary fibrosis. *Clin Exp Immunol.* 119: 203-9, 2000
 32. Yazawa N. Kikuchi K. Ihn H. Fujimoto M. Kubo M. Tamaki T. Tamaki K: Serum levels of tissue inhibitor of metalloproteinases 2 in patients with systemic sclerosis. *J Am Acad Dermatol.* 42: 70-5, 2000
 33. Yamane K. Ihn H. Kubo M. Yazawa N. Kikuchi K. Soma Y. Tamaki K: Increased serum levels of soluble vascular cell adhesion molecule 1 and E-selectin in patients with localized scleroderma. *J Am Acad Dermatol.* 42: 64-9, 2000
 34. Salgado CG, Nakamura K, Sugaya M, Tada Y, Asahina A, Fukada S, Koyama Y, Irie S, Tamaki K. Differential effects of cytokines and immunosuppressive drugs on CD40, B7-1, and B7-2 expression on purified epidermal Langerhans cells. *J Invest Dermatol* 113: 1021-7, 1999.
 35. Kanda N, Tamaki K. Ganglioside GD1b suppresses immunoglobulin production by human peripheral blood mononuclear cells. *Exp Hematol* 27: 1487-93, 1999.
 36. Sugaya M, Nakamura K, Tamaki K. Interleukins 18 and 12 synergistically upregulate interferon-gamma production by murine dendritic epidermal T cells. *J Invest Dermatol* 113: 350-4, 1999.
 37. Salgado CG, Nakamura K, Sugaya M, Tada Y, Asahina A, Koyama Y, Irie S, Tamaki K. Functional CD40 ligand is expressed on epidermal Langerhans cells. *J Leukocyte Biol* 66: 281-5, 1999.
 38. Kubo M, Ihn H, Sato S, Kikuchi K, Tamaki K. Prevalence and antigen specificity of anti-histone antibodies in patients with polymyositis/dermatomyositis. *J Invest Dermatol* 112: 711-5, 1999.
 39. Watanabe T, Tsuchida T, Kanda N, Mori K, Hayashi Y, Tamaki K. Anti-a-fodrin antibodies in Sjogren syndrome and lupus erythematosus. *Arch Dermatol* 135: 535-9, 1999.
 40. Kanda N, Tamaki K. Estrogen enhances immunoglobulin production by human PBMCs. *J Allergy Clin Immunol* 103: 282-8, 1999.
 41. Kanda N, Tsuchida T, Tamaki K. Estrogen enhancement of anti-double-stranded DNA antibody and immunoglobulin G production in peripheral blood mononuclear cells from patients with systemic lupus erythematosus. *Arthritis Rheum* 42: 328-37, 1999.
 42. Kubo M, Kikuchi K, Nashiro K, Kakinuma T, Hayashi N, Nanko H, Tamaki K. Expression of fibrogenic cytokines in desmoplastic malignant melanoma. *Br J Dermatol* 139: 192-7, 1998.

43. Kanda N, Tamaki K. Ganglioside CQ1b enhances Ig production by human PBMCs. *J Allergy Clin Immunol* 102: 813-20, 1998.
44. Kubo M, Kikuchi K, Fujimoto M, Tamaki K. Serum concentration of carboxyterminal propeptide of type 1 procollagen and tissue inhibitor of metalloproteinase 1 in patients with dermatomyositis. *Arch Dermatol Res* 290: 253-7, 1998.
45. Kawabata Y, Tamaki K. Distinctive dermatoscopic features of acral lentiginous melanoma in situ from plantar melanocytic nevi and their histopathologic correlation. *J Cutan Med Surg* 2: 199-204, 1998.
46. Kikuchi K, Kubo M, Kadono T, Yazawa N, Ihn H, Tamaki K. Serum concentrations of vascular endothelial growth factor in various collagen diseases. *Br J Dermatol* 139: 1049-51, 1998.
47. Watanabe T, Tsuchida T, Ito Y, Kanda N, Ueda Y, Tamaki K. Annular erythema associated with lupus erythematosus / Sjogren's syndrome. *J Am Acad Dermatol* 36: 214-8, 1997.
48. Kanda N, Tsuchida T, Tamaki K. Testosterone suppresses anti-DNA antibody production in peripheral mononuclear cells from patients with systemic lupus erythematosus. *Arthritis Rheum* 40: 1703-11, 1997.
49. Kikuchi K, Kadono T, Furue M, Tamaki K. Tissue inhibitor of metalloproteinase-1 (TIMP-1) may be an autocrine growth factor in scleroderma fibroblasts. *J Invest Dermatol* 108: 281-4, 1997.
50. Furue M, Kato M, Nakamura K, Nashiro K, Kikuchi K, Okochi H, Miyazono K, Tamaki K. Dysregulated expression of transforming growth factor β and its type I and II receptors in basal cell carcinoma. *Int J Cancer* 71: 505-9, 1997.

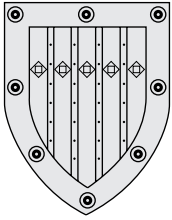

Department of Plastic and Reconstructive Surgery

Outline and Research Objectives

The Department of Plastic and Reconstructive Surgery was established in 1960 as the first independent clinical department in Japan. Clinical activities were initially focused on congenital anomalies and skin surgery. In the 1970's, however, surgical techniques such as microsurgery, craniofacial surgery, tissue expansion, etc. were developed, and our activities were significantly expanded so that could lead the world in the field of the free tissue transfers, head and neck cancer reconstruction, hand surgery, craniomaxillofacial surgery, etc. Recently, cosmetic surgery and aesthetic dermatology were also added to our clinical field, and now we have the greatest number of patients for cosmetic purposes among all universities in Japan. Current research objectives are tissue and cell engineering from somatic stem cells, hair regeneration, anti-aging effects of hormones on skin, embryonic development of congenital anomaly, and application of retinoids to skin and keloids.

Faculties and Students:

- Professor and Chair Kiyonori Harii, M.D. (1989-)
- Associate Professors Hirotaka Asato, M.D. (1998-)
- Lecturer Kotaro Yoshimura, M.D. (1998-)
- Associates4
- Postdoctoral Fellows.....5
- Graduate Students4
- Secretaries2

Past Research and Major Accomplishments

Professor Harii has developed a number of surgical techniques in reconstructive microsurgery such as muscle transplantation for facial reanimation in facial-paralyzed patients, and microsurgical reconstruction of head and neck cancer patients. These activities were published in various international medical journals and textbooks. He accepted a number of trainees from countries all over the world, who studied and mastered microsurgery in our laboratory.

Current Research

We have several research projects, both basic and clinical. In basic research, molecular and cellular approaches to reveal the mechanism of congenital anomalies, such as cleft lips and palates, ear deformities, and craniofacial deformities, are ongoing. We are seeking genes which can cause those anomalies. In addition, influences of hormones, especially estrogen, on skin aging are being investigated. Genes, which can be upregulated or downregulated by estrogen in dermal fibroblasts, are being investigated by microarray technique. We are trying to determine the mechanism by which estrogen affects the chronological

aging of skin. The third one is on hair regeneration. We harvest and culture dermal papilla cells from hair follicles, which can transform epidermal stem cells into hair follicles. We have tried to determine critical factors released by dermal papilla cells in order to apply to a practical treatment of alopecia. The last one is mesenchymal stem cells extraction from lipoaspirates. We are trying to transform the stem cells into adipocytes, chondrocytes, osteoblasts, dermal fibroblasts, and others for clinical use. The optimal protocols to culture and transform the stem cells have been investigated.

Clinically, we have attempted to establish a classification of pigmented skin lesions. Also, the mechanism of hyperpigmentation and rational therapies are currently being established. Clinical effects of a chemopreventional therapy for keloids using retinoids are now under estimation.

Future Prospects

Our research projects will be more focused on tissue and cell engineering using somatic (mesenchymal) stem cells in the future. Cosmetic augmentation of soft tissue such as breasts, cheek, and eyelids may be clinically available using adipose cells or tissues produced by mesenchymal stem cells extracted from lipoaspirates. The stem cells could be applied to therapies of a wide variety of diseases such as hepatic dysfunction, arterial sclerosis, joint cartilage problems, myocardial infarction, leukemia, etc.

Research Grants

- 1) Kotaro Yoshimura, Grants-in aid for scientific research (B) 2002-2003, Molecular biological research on MMPs and TIMPs expression of human keloids.
- 2) Hirotaka Asato, Grants-in aid for scientific research (B) 2002-2003, Study on a specific skeletogenic potential of the cranial neural crest cells.
- 3) Kiyonori Harii, Grants-in aid for scientific research (A), 2000-2001, Evaluation of rejection at the transplantation of cultured cell and induction of local tolerance without systemic immunosuppression.
- 4) Kotaro Yoshimura, Grants-in aid for scientific research (B), 2000-2001, Molecular biological research on actions of retinoids on wound healing and pigmentation in skin.
- 5) Shinichi Wakita, Grants-in aid for scientific research (B), 1999-2000, Mesenchymal stem cells; actions in wound healing and application to tissue engineering.

Select Publications

1. Takushima A, Asato H, Harii K, Masashi S. Simultaneous harvest of intercostal nerves and elevation of rectus abdominis musculocutaneous flap for facial nerve cable grafting. *Plast Reconstr Surg* 110, 541-544, 2002.
2. Yoshimura K, Asato H, Jejurikar SS, Cederna PS, Urbanek MG, Kuzon WM Jr. The effect of two episodes of denervation and reinnervation on skeletal muscle contractile function. *Plast Reconstr Surg* 109, 212-219, 2002.
3. Takushima A, Harii K, Asato H, Yamada A. Neurovascular free-muscle transfer to treat facial paralysis associated with hemifacial microsomia. *Plast Reconstr Surg* 109, 1219-1227, 2002.
4. Kimata Y, Uchiyama K, Sakuraba M, Ebihara S, Hayashi R, Haneda T, Onitsuka T, Asakage T, Nakatsuka T, Harii K. Velopharyngeal function after microsurgical reconstruction of lateral and superior oropharyngeal defects. *Laryngoscope* 112, 1037-1042, 2000.
5. Harii K., Asato H.: Facial reanimation. *The Unfavorable Result in Plastic Surgery*, 3rd Ed. (ed. by Goldwyn, R.M., Cohen, M.N.), Lippincott, Williams and Wilkins, Philadelphia, 2001
6. Kitano Y, Yoshimura K, Uchida G, Sato K, Harii K. Pretreatment with topical all-trans-retinoic acid is beneficial for wound healing in genetically diabetic mice. *Arch Dermatol Res* 293, 515-521, 2001.
7. Ichioka S, Nakatsuka T, Ohura N, Sato Y, Harii K. Clinical use of amrinone (a selective phosphodiesterase III inhibitor) in reconstructive surgery. *Plast Reconstr Surg* 108, 1931-1937, 2001.
8. Nagase T, Nakamura S, Harii K, Osumi N. Ectopically localized HNK-1 epitope perturbs migration of the midbrain neural crest cells in Pax6 mutant rat. *Dev Growth Differ* 13, 683-692, 2001.
9. Takushima A, Harii K, Asato H, Nakatsuka T, Kimata Y. Mandibular reconstruction using microvascular free flaps: a statistical analysis of 178 cases. *Plast Reconstr Surg* 108, 1555-1563, 2001.
10. Yoshimura K, Tsukamoto K, Okazaki M, Virador VM, Lei TC, Suzuki Y, Uchida G, Kitano Y, Harii K. Effects of all-trans retinoic acid on melanogenesis in pigmented skin equivalents and monolayer culture of melanocytes. *J Dermatol Sci* 27, S68-75, 2001.
11. Nakagawa M, Miyagoe-Suzuki Y, Ikezoe K, Miyata Y, Nonaka I, Harii K, Takeda S. Schwann cell myelination occurred without basal lamina formation in laminin alpha2 chain-null mutant (dy3K/dy3K) mice. *Glia* 35, 101-110, 2001.
12. Yoshimura K, Harii K, Masuda Y, Takahashi M, Aoyama T, Iga T. Usefulness of a narrow-band reflectance spectrophotometer in evaluating effects of depigmenting treatment. *Aesthetic Plast Surg* 25, 129-133, 2001.
13. Nagase T, Shimoda Y, Sanai Y, Nakamura S, Harii K, Osumi N.: Differential expression of two glucuronyltransferases synthesizing HNK-1 carbohydrate epitope in the sublineages of the rat myogenic progenitors. *Mech Dev* 98, 145-149, 2000.
14. Kimata Y, Uchiyama K, Ebihara S, Saikawa M, Hayashi R, Haneda T, Ohyama W, Kishimoto S, Asai M, Nakatsuka T, Harii K.: Postoperative complications and functional results after total glossectomy with microvascular reconstruction. *Plast Reconstr Surg* 106, 1028-1035, 2000.
15. Kimata Y, Uchiyama K, Ebihara S, Sakuraba M, Iida H, Nakatsuka T, Harii K. Anterolateral thigh flap donor-site complications and morbidity. *Plast Reconstr Surg* 106, 584-589, 2000.
16. Ichioka S, Nakatsuka T, Ohura N, Sato Y, Harii K.: Topical application of amrinone (a selective phosphodiesterase III inhibitor) for relief of vasospasm. *J Surg Res* 93, 149-155, 2000.
17. Gonda K, Nakaoka T, Yoshimura K, Otawara-Hamamoto Y, Harii K. Heterotopic ossification of degenerating rat skeletal muscle induced by adenovirus-mediated transfer of bone morphogenetic protein-2 gene. *J Bone Miner Res* 15, 1056-1065, 2000.
18. Yoshimura K, Harii K, Aoyama T, Iga T. Experience with a strong bleaching treatment for skin hyperpigmentation in Orientals. *Plast Reconstr Surg* 105, 1097-1108, 2000.
19. Yoshimura K, Ouchi K, Wakita S, Uda K, Harii K. Surgical correction of cryptotia with superiorly based superficial mastoid fascia and skin paddle. *Plast Reconstr Surg* 105, 836-841, 2000.
20. Kimata Y, Uchiyama K, Ebihara S, Kishimoto S, Asai M, Saikawa M, Ohyama W, Haneda T, Hayashi R, Onitsuka T, Nakatsuka T, Harii K. Comparison of innervated and noninnervated free flaps in oral reconstruction. *Plast Reconstr Surg* 104, 1307-1313, 1999.
21. Shimoda Y, Tajima Y, Nagase T, Harii K, Osumi N, Sanai Y. Cloning and expression of a novel galactoside beta1, 3-glucuronyltransferase involved in the biosynthesis of HNK-1 epitope. *J Biol Chem* 274, 17115-17122, 1999.

22. Kimata Y, Uchiyama K, Sekido M, Sakuraba M, Iida H, Nakatsuka T, Harii K. Anterolateral thigh flap for abdominal wall reconstruction. *Plast Reconstr Surg* 103, 1191-1197, 1999.
23. Nakatsuka T, Harii K, Takushima A, Yoshimura K, Ichioka S, Sugawara M, Ichimura K, Seto Y, Nagawa H. Prefabricated free jejunal transfer: a new reconstructive technique for high pharyngeal defects. *Plast Reconstr Surg* 103, 458-64, 1999.
24. Harii K, Asato H, Nakatsuka T, Ebihara S. Reconstructive plastic surgery in cancer treatment: surgery for quality of life. *Jap Soc Clin Oncol* 4, 193-201, 1999.
25. Yoshimura K, Harii K. A regenerative change during muscle adaptation to denervation in rats. *J Surg Res* 81, 139-146, 1999.
26. Gonda K, Okamoto H, Takuwa N, Yatomi Y, Okazaki H, Sakurai T, Kimura S, Sillard R, Harii K, Takuwa Y. The novel sphingosine 1-phosphate receptor AGR16 is coupled via pertussis toxin-sensitive and -insensitive G-proteins to multiple signalling pathways. *Biochem J* 337, 67-75, 1999.
27. Harii, K. : Free groin flap reconstruction of severe burn neck constructure. *Grabb's encyclopedia of flaps second edition* (eds. Strauch, B. et al.) vol.1, pp.478-480, Lippincott-Raven, Philadelphia, 1998.
28. Harii, K. Asato, H. : Microneurovascular free gracilis muscle transfer for facial reanimation. *Grabb's encyclopedia of flaps second edition* (eds. Strauch, B. et al.) vol.1, pp.521-524, Lippincott-Raven, Philadelphia, 1998.
29. Harii, K. : Microvascular free transfer of the groin skin flap. *Grabb's encyclopedia of flaps second edition* (eds. Strauch, B. et al.) vol.II, pp.1110-1111, Lippincott-Raven, Philadelphia, 1998.
30. Harii, K. : Microvascular free transfer of a groin skin flap. *Grabb's encyclopedia of flaps second edition* (eds. Strauch, B. et al.) vol.III, pp.1328-1330, Lippincott-Raven, Philadelphia, 1998.
31. Hirabayashi S, Sugawara Y, Sakurai A, Harii K, Park S. Frontoorbital advancement by gradual distraction. Technical note. *J Neurosurg* 89, 1058-61, 1998.
32. Kimata Y, Uchiyama K, Ebihara S, Nakatsuka T, Harii K. Anatomic variations and technical problems of the anterolateral thigh flap: a report of 74 cases. *Plast Reconstr Surg* 102, 1517-1523, 1998.
33. Yoshimura K, Harii K, Asato H, Ueda K, Yamada A. Immunohistochemical analysis of clinically transplanted muscles. *J Surg Res* 79, 31-38, 1998.
34. Harii K, Asato H, Yoshimura K, Sugawara Y, Nakatsuka T, Ueda K. One-stage transfer of the latissimus dorsi muscle for reanimation of a paralyzed face: a new alternative. *Plast Reconstr Surg* 102, 941-951, 1998.
35. Takushima A, Kitano Y, Harii K. Osteogenic potential of cultured periosteal cells in a distracted bone gap in rabbits. *J Surg Res* 78, 68-77, 1998.
36. Yoshimura K, Kuzon WM, Harii K. Myosin heavy chain expression in skeletal muscle autografts under neural or aneural conditions. *J Surg Res* 75, 135-147, 1998.
37. Ueda K, Harii K, Asato H, Yamada A. Neurovascular free muscle transfer combined with cross-face nerve grafting for the treatment of facial paralysis in children. *Plast Reconstr Surg* 101, 1765-1773, 1998.
38. Ichioka S, Nakatsuka T, Sato Y, Shibata M, Kamiya A, Harii K. Amrinone, a selective phosphodiesterase III inhibitor, improves microcirculation and flap survival: a comparative study with prostaglandin E1. *J Surg Res* 75, 42-48, 1998.
39. Kitano Y, Kurihara H, Kurihara Y, Maemura K, Ryo Y, Yazaki Y, Harii K. Gene expression of bone matrix proteins and endothelin receptors in endothelin-1-deficient mice revealed by in situ hybridization. *J Bone Miner Res* 13, 237-244, 1998.
40. Nakaoka T, Gonda K, Ogita T, Otawara-Hamamoto Y, Okabe F, Kira Y, Harii K, Miyazono K, Takuwa Y, Fujita T. Inhibition of rat vascular smooth muscle proliferation in vitro and in vivo by bone morphogenetic protein-2. *J Clin Invest* 100, 2824-2832, 1998.
41. Ichioka S, Shibata M, Kosaki K, Sato Y, Harii K, Kamiya A. Effects of shear stress on wound-healing angiogenesis in the rabbit ear chamber. *J Surg Res* 72, 29-35, 1997.
42. Ueda K, Harii K, Yamada A. Free vascularized double muscle transplantation for the treatment of facial paralysis. *Plast Reconstr Surg* 95, 1288-1296, 1995.
43. Yamada A, Harii K, Ueda K, Asato H, Tanaka H. Versatility of a cross-leg free rectus abdominis flap for leg reconstruction under difficult and unfavorable conditions. *Plast Reconstr Surg* 95, 1253-1257, 1995.
44. Kimata Y, Uetake M, Tsukada S, Harii K. Follow-up study of patients treated for ingrown nails with the nail matrix phenolization method. *Plast Reconstr Surg* 95, 719-724, 1995.
45. Ueda K, Harii K, Yamada A. Electromyographic study of functional recovery of free vascularized muscles grafted to the face. *Plast Reconstr Surg* 95, 296-304, 1995.
46. Kawashima T, Yamada A, Ueda K, Asato H, Harii K. Tissue expansion in facial reconstruction. *Plast Reconstr Surg* 94, 944-950, 1994.
47. Ueda K, Harii K, Yamada A. Free neurovascular muscle transplantation for the treatment of facial paralysis using the hypoglossal nerve as a recipient motor source. *Plast Reconstr Surg* 94, 808-817, 1994.
48. Komuro Y, Takato T, Harii K, Yonehara Y. The histologic analysis of distraction osteogenesis of the mandible in rabbits. *Plast Reconstr Surg* 94, 152-159, 1994.
49. Ueda K, Harii K, Yamada A. Long-term follow-up of nerve conduction velocity in cross-face nerve grafting for the treatment of facial paralysis. *Plast Reconstr Surg* 93, 1146-1149, 1994.
50. Nakatsuka T, Harii K, Yamada A, Asato H, Ebihara S. Versatility of a free inferior rectus abdominis flap for head and neck reconstruction: analysis of 200 cases. *Plast Reconstr Surg* 93, 762-769, 1994.

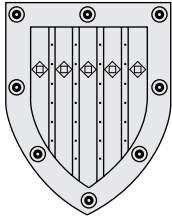

Department of Oral and Maxillofacial Surgery

Outline and Research Objectives

Department of Oral and Maxillofacial Surgery, commenced by Dr. Hisashi Ishihara in 1900, is one of the oldest departments in Graduate School of Medicine, University of Tokyo. Professor Takato is the 7th professor in our department. The department has been the center of the clinical and basic research in oral and maxillofacial region in Japan. Congenital anomalies, jaw deformities, benign and malignant oral tumors, facial bone fractures, temporomandibular joint diseases, and dental treatment in systemic diseases are mainly treated and researched in our department. Multidisciplinary treatment teamed by plastic surgeons, oral surgeons, orthodontists, prothodontists, etc. is characteristic and has performed excellent results in clinical works. In research fields, we have mainly performed the experimental studies on the regenerative capacity of tissues, especially bone, periosteum, cartilage, perichondrium, vessels, nerve, skin, etc. At present, we are focusing on tissue engineering in research works especially in bone, cartilage, vessels. Professor Takato has established Division of Tissue Engineering in Tokyo University Hospital and our department has two endowment departments: Department of Cartilage and Bone Regeneration (Menicon Co.,Ltd.) and Department of Clinical Vascular Regeneration (Daiichi Pharmaceutical Co., Ltd.) in Tissue Engineering Division. These departments have 1 associate professor, 1staff, and 4 graduate students in each. These staff are focusing on translational research works in maxillofacial regions.

Research Objectives

- 1) Multidisciplinary treatment of facial deformities in patients with cleft lip and palate or other congenital maxillofacial anomalies
- 2) Multidisciplinary treatment of dentomaxillofacial deformities, fractures and temporomandibular diseases
- 3) Multidisciplinary treatment of malignant tumors in head and neck region
- 4) Reconstruction using bone and cartilage grafts in maxillofacial region
- 5) Clinical and research works on distraction osteogenesis in maxillofacial region
- 6) Basic research of bone metabolism
- 7) Basic research on osteogenic capacity of periosteum
- 8) Basic research on capacity of perichondrial regeneration
- 9) Basic research on growth plate
- 10) Tissue engineering on bone, cartilage, and vessels, etc

Faculties and Students

Professor and Chair	Tsuyoshi Takato, M.D., PhD. (since 1996)
Associate Professor	Takafumi Susami, D.D.S., PhD.
Lecturer	Yoshiyuki Mori, D.D.S., PhD. Tomoaki Eguchi, M.D., PhD. Tetsuya Yoda, D.D.S., PhD. Hisako Hikiji, D.D.S., PhD.
Associate	10
Clinical Staff.....	7
Resident	9
Graduate student	12
Research student.....	1

Secretary2

Past Research and Major Accomplishments

1. Clinical research:

- 1) Multidisciplinary treatment of facial deformities in patients with cleft lip and palate or other congenital maxillofacial anomalies
- 2) Multidisciplinary treatment of dentomaxillofacial deformities, fractures and temporomandibular diseases
- 3) Multidisciplinary treatment of malignant tumors in head and neck region

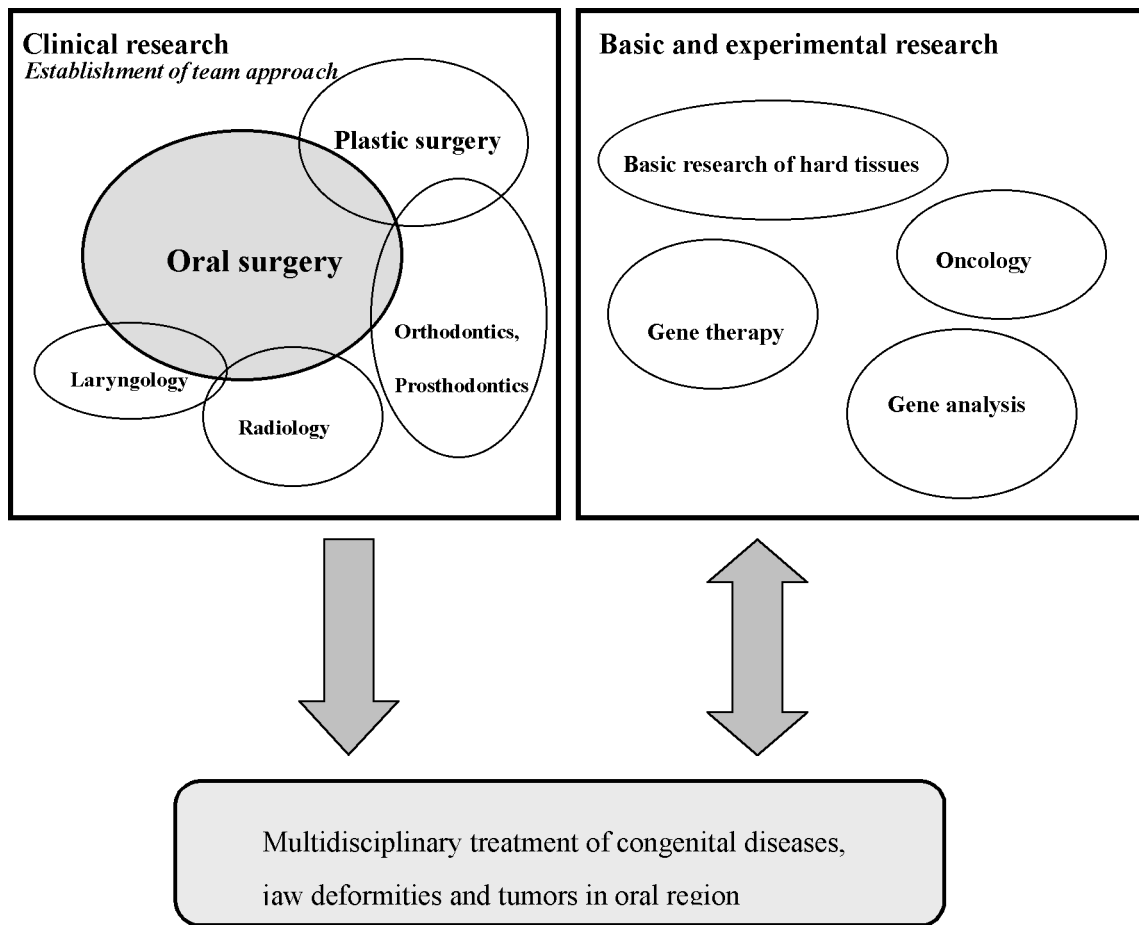

- 4) Facial bone lengthening by distraction osteogenesis
- 5) Correction of facial deformity in cleft lip and palate patients
- 6) Speech problems in cleft lip and palate patients
- 7) Facial growth in craniofacial anomalies
- 8) Evaluation of the treatment outcomes in patients with cleft lip and/or palate
- 9) Combined surgical-chemical-radiological treatment for malignant tumors
- 10) Development of dental implant
- 11) Surgical-orthodontic treatment of dentofacial deformities
- 12) Effects of arthrocentesis or therapeutic exercises for temporomandibular disorders
- 13) Effects of masticatory force on facial form
- 14) Non-surgical treatment system for facial bone fractures

2. Basic and experimental research:

- 1) Osteogenic capacity of periosteum
- 2) Capacity of perichondrial regeneration
- 3) Osteogenic capacity of growth plate
- 4) Development of various types of new skin flaps
- 5) Metabolism of poly ADP-ribose in DNA repair and cell differentiation
- 6) Gene analysis of congenital anomalies of oral and maxillofacial region

- 7) Effect of free radicals on bone metabolism
- 8) Intracellular calcium handling on osteoblasts
- 9) Differentiation mechanism of osteoblasts in terms of cell cycle molecule
- 10) Functional analysis on domains of P130Cas in actin cytoskeleton organization, cell migration, and Src transformation
- 11) Osteochondrogenic differentiation of bone marrow derived mesenchymal stem cells by spheroid culture
- 12) Cloning of the 5'Upstream Region of the Rat p16 Gene and Its Role in Silencing
- 13) Studies on relationship between dystrophin associated protein and advanced heart failure
- 14) Mandibular lengthening by floating bone method
- 15) Periodontal tissue regeneration on dental implants
- 16) Characterization of skin derived multipotent stem cells, especially differentiation mechanism into neuronal cell
- 17) Bone and cartilage repair in dentomaxillofacial region using tissue engineering technique

Current Research

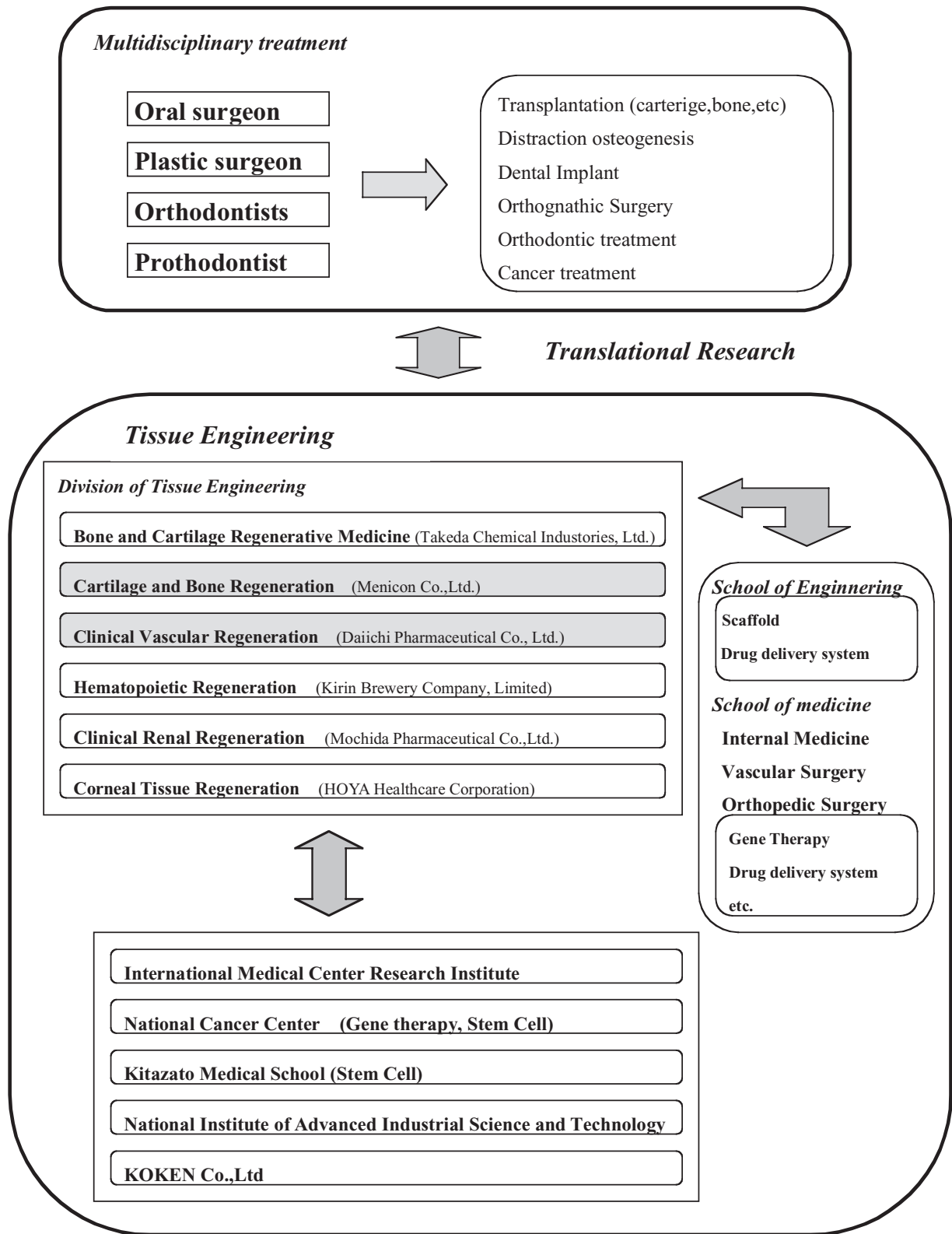

Future Prospects

Our department has been the center of the treatment and research in dentomaxillofacial diseases for the last century in Japan. For decade years, we established the system of the multidisciplinary treatment for diseases in dentaomaxillofacial region. We are now in the next step to develop the new treatment for deficiency of dentomaxillofacial region using tissue-engineering technique. For this purpose, Professor Takato established the Division of Tissue Engineering in Tokyo University Hospital in 2001. We have been researching the development of the materials, tissues and organs which are constructed with the tissue-engineering technique. Three-dimensional construction of cartilage and bone with neovascularization is our most important theme to investigate. These regenerated tissues would repair the deficiency of the dentomaxillofacial region without the harvest of grafted materials from the donor sites. To achieve this translational research, we are cooperating with several companies and Ministries.

Research Grants

The Ministry of Education, Science, Culture and Technology
Research Grant B2 (1995-1996)
Research Grant B1 (1997-1998)
Research Grant B2 (1997-1998)
Research Grant B2 (1999—2001)
Grant for development of advanced medicine (2002-2004)

Select Publications

1. Harii K., Ebihara S., Ono I., Saito H., Terui S., and Takato T.: Pharyngoesophageal reconstruction using a fabricated forearm free flap. *Annals of Plastic Surgery*, 85: 463-474, 1985
2. Takato T., Ono I., Ebihara S., and Saeki T.: Repair of stenosed tracheostoma. *Journal of Oto-Rhino-Laryngology & its Related Specialties*, 47: 299-302, 1985
3. Takato T., Ono I., Ebihara S., and Matsumoto T.: Reconstruction of the oral commissure. *Oral Surgery, Oral Medicine, Oral Pathology*, 62: 132-134, 1986
4. Takato T., Harii K., Nakatsuka T., Ueda K., and Ohtake T.: Vascularized periosteal graft : An experimental study using two different forms of tibial periosteum in rabbits. *Plastic and Reconstructive Surgery*, 78: 489-497, 1986
5. Takato T., Harii K., Ebihara S., Ono I., Yoshizumi T., and Nakatsuka T.: Oral and pharyngeal reconstruction using the free forearm flap. *Archives of Otolaryngology*, 113: 873-879, 1987
6. Takato T., Harii K., and Nakatsuka T.: The development of bone after perichondrial grafting : An experimental study using ear and rib perichondrium in rabbits. *British Journal of Plastic Surgery*, 40: 636-641, 1987
7. Takato T., Harii K., and Nakatsuka T.: The sequential evaluation of bone scintigraphy : an analysis of revascularised bone grafts. *British Journal of Plastic Surgery*, 41: 262-269, 1988
8. Takato T., Harii K., and Nakatsuka T.: Osteogenic capacity of vascularized periosteum : experimental study using rib periosteum in rabbits. *British Journal of Plastic Surgery*, 41: 528-532, 1988
9. Takato T., Harii K., Nakatsuka T., and Ohtake T.: Experimental study of vascularized bone : Quantitative analysis of bone scintigraphy and histology. *Journal of Reconstructive Microsurgery*, 4: 391-397, 1988
10. Takato T., Ohsone H., and Tsukakoshi H.: Treatment of severe microstomia by swallowing caustic soda. *Oral surgery, Oral medicine, Oral pathology*, 67: 20-24, 1989
11. Takato T., Kamei M., Kato K., and Kitano I.: Cleft palate in the Beckwith-Wiedemann syndrome. *Annals of Plastic Surgery*, 22: 347-349, 1989
12. Takato T., Itoh M., Yokota M., Kyoku I., Kitano M., Misuhara T., and Sakamoto K.: Delayed thoracic closure after cardiac surgery in infants. *British Journal of Plastic Surgery*, 44: 106-108, 1991
13. Takato T., Zuker R.M., and Turley C.B.: Prefabrication of skin flaps using vein graft : an experimental study in rabbits. *British Journal of Plastic Surgery*, 44: 593-598, 1991
14. Takato T., Nakai H., Yonehara Y., Takeda H., Susam P., Kitano Y., and Kato K.: Binder's syndrome : Peculiarities in Japanese patients. *Annals of Plastic Surgery*, 27: 371-381, 1991
15. Takato T., Zuker R.M., and Turley C.B.: Viability and versatility of arterialized venous perfusion flaps and prefabricated flaps : an experimental study in rabbits. *Journal of Reconstructive Microsurgery*, 8: 111-119, 1992
16. Takato T., Komuro Y., Yonehara Y., and Zuker R.M.: Viability and versatility of arterialized venous perfusion flaps and prefabricated flaps : an experimental study in rabbits. *British Journal of Plastic Surgery*, 48: 111-119, 1993
17. Takato T., Komuro Y., Yonehara Y., and Zuker R.M.: Prefabricated venous flaps : an experimental study in rabbits. *British Journal of Plastic Surgery*, 46: 122-126, 1993
18. Takato T., Harii K., Komuro Y., and Yonehara Y.: Experimental study on growth of epiphysial plate : free graft in rabbits. *British Journal of Plastic Surgery*, 46: 416-420, 1993
19. Komuro Y., Takato T., Yamada A., and Yonehara Y.: Experimental study of prefabricated flaps using vein grafts. *Journal of Reconstructive Microsurgery*, 9: 373-380, 1993
20. Takato T., Harii K., Komuro Y., Yonehara Y., and Susami T.: Mandibular lengthening by gradual distraction : analysis using accurate skull replicas. *British Journal of Plastic Surgery*, 46: 686-693, 1993

21. Komuro Y., Takato T., Harii K., and Yonehara Y.: The histological analysis of distraction osteogenesis of mandible in rabbits. *Plastic and Reconstructive Surgery*, 94: 152-159, 1994
22. Takato T., Harii K., Yonehara Y., Komuro Y., Susami T., and Uoshima K.: Correction of the cleft nasal deformity with an L-shaped iliac bone graft. *Annals of Plastic Surgery*, 33: 486-493, 1994
23. Komori Y., Takato T., and Akagawa T.: Use of a laser-hardened three dimensional replica for simulated surgery. *Journal of Oral and Maxillofacial Surgery*, 52: 516-521, 1994
24. Takato T., Yonehara Y., and Susami T.: Early correction of the nose in unilateral cleft lip patients using an open method : A 10-year review. *Journal of Oral and Maxillofacial Surgery*, 53: 28-33, 1995
25. Takato T., Yonehara Y., and Susami T.: Columella lengthening using a cartilage graft in the bilateral cleft lip-associated nose : Choice of cartilage according to age. *Journal of Oral and Maxillofacial Surgery*, 53: 149-157, 1995
26. Takato T., Yonehara Y., Mori Y., Sakamoto Y., and Susami T.: Use of Cantilever Iliac Bone Grafts for Reconstruction of Cleft Lip-Associated Nasal Deformities. *Journal of Oral and Maxillofacial Surgery*, 53: 757-762, 1995
27. Komori T., Takato T., and Yokoyama K.: Integration of dental models in a three-dimensional replica. *Journal of Oral and Maxillofacial Surgery*, 53: 621-624, 1995
28. Komori T., Matsumoto K., Yokoyama K., and Takato T.: A Morphological Study of Bone Cuts with Aluminium Oxide Particles. *Japanese Journal of Oral Diagnosis/ oral Medicine*. 8: 208-212, 1995
29. Takato T., Yonehara Y., Susami T., and Uoshima K.: Modification of the Abbe Flap for Reconstruction fo the Vermilion Tubercle and Cupid's Bow in Cleft Lip Patients. *Journal of Oral and Maxillofacial Surgery*, 54: 256-261, 1996
30. Komori T., Yokoyama K., Takato T., and Matsumoto K.: Clinical application of the erbium:YAG laser for apicoectomy. *Journal of Endodontics*, 23:748-750, 1997
31. Nozaki T., Masutani M., Sugimura T., Takato T., and Wakabayashi K.: Abrogation of G1 arrest after DNA damages is associated with constitutive expression of Mdm2, Cdk4, and Irf1 mRNAs in the BALB/c 3T3 A31 Variant 1-1 Clone. *Biochemical & Biophysical Research Communications*, 233: 1997
32. Hikiji H., Wee Soo Shin, Oida S., Takato T, Koizumi T, and Toyooka T: Direct action of nitric oxide on osteoblastic differentiation. *FEBS Letters*, 410:238-242, 1997
33. Yonehara Y., Takato T., Harii K., Hirabayashi S., Susami T., Komori T., Matsumoto S., Hikiji H., and Nakatsuka T.: Secondary lengthening of the reconstructed mandible using a gradual distraction technique-two case reports. *British Journal of Plastic Surgery*, 51: 356-358, 1998
34. Nakatsuka T., Harii K., Yamada A., Yonehara Y., Takato T., Kawahara N., Sakaki T., Yamasoba T., Nibu K., and Ebihara S.: Immediate Free Flap Reconstruction for Head and Neck Pediatric Malignancies. *Annals of Plastic Surgery*, 40(6): 594-599, 1998
35. Sakata Y., Tokunaga K., Yonehara Y., Bannai M., Tsuchiya N., Susami T., and Takato T.: Significant association of HLA-B and HLA-DRB1 alleles with cleft lip with or without cleft palate. *Tissue Antigens*, 53: 147-152, 1999
36. Takushima A., Susami T., Nakatsuka T., Harii K., and Takato T.: Multi-Bracket Appliance in Management of Mandibular Reconstr uction with Vascularized Bone Graft. *Japanese Journal of Clinical Oncology*, 29: 119-126, 1999
37. Yonehara Y., Takato T., Matsumoto S., Nakatsuka T.: Distraction of scarred soft tissue before secondary bone grafting. *International Journal of Oral Maxillofacial Surgery*, 28: 347-348, 1999
38. Yonehara Y., Nakatsuka T., Ichioka I., Takato T., Matsumoto S., and Yamada A.: Intramuscular haemangioma of the anterior chest wall. *British Journal of Plastic Surgery*, 53: 257-259, 2000
39. Yonehara Y., Takato T., Matsumoto S., Mori Y., Nakatsuka T., and Hikiji H.: Correction of cleft lip nasal deformity in Orientals with a cantilevered iliac bone graft. *Scandinavian Journal of Plastic and Reconstructive Surgery and Hand Surgery*, 34: 137-143, 2000
40. Yonehara Y., Takato T., Susami T., and Mori Y.: Correction of Micrognathia Attributable to Ankylosis of the Temporomandibular Joint Using a Gradual Distraction Technique: Case Report. *Journal of Oral and Maxillofacial Surgery*, 58:1415-1418, 2000
41. Chikazu D., Shindo M., Iwasaka T., Katagiri M., Manabe N., Takato T., Nakamura K., and Kawaguchi H.: A Novel Synthetic Triazolotriazepine Derivative JTT-606 Inhibits Bone Resorption by Down-Regulation of Action and Production of Bone Resorptive Factors. *Journal of Bone Miner Research*, 15(4):674-682, 2000
42. Hikiji H., Shin WS, Koizumi T., Takato T., Susami T., Koizumi Y., Okai-Matsuo Y., and Toyooka T.: Peroxynitrite production by TNF-alpha and IL-1beta: implication for suppression of osteoblastic differentiation. *American Journal of Physiology - Endocrinology & Metabolism*, 278: E1031-1037, 2000
43. Hikiji H., Takato T., Matsumoto S., and Mori Y.: Experimental Study of Reconstruction of the Temporomandibular Joint Using a Bone Transport Technique. *Journal of Oral and Maxillofacial Surgery*, 58: 1270-1276, 2000
44. Chikazu D., Hakeda Y., Nemoto K., Itabashi A., Takato T., Kumegawa M., Nakamura K., and Kawaguchi H.: Fibroblast growth factor-2 directly stimulates mature osteoclasts activity through autophosphorylation of FGF receptor 1. *Journal of Biological Chemistry*2000, 275: 31444-31450, 2000

45. Katagiri M., Hakeda Y., Chikazu D., Ogasawara T., Takato T., Kumegawa M., Nakamura K., and Kawaguchi H. :Mechanism of Stimulation of Osteoclastic Bone Resorption through Gas6/Tyro3, a Receptor Tyrosine Kinase Signaling in Mouse Osteoclasts. *Journal of Biological Chemistry*2001, 276(10):b7376-7382, 2001
46. Eguchi T., Asato H., Takushima A., Takato T., and Harii K. : Surgical repair for congenital macrostomia: A vermilion square flap method. *Annals of Plastic Surgery* 47:629-635, 2001
47. Chikazu D., Katagiri M., Ogasawara T., Ogata N., Shimoaka T., Takato T., Nakamura K., and Kawaguchi H.: Regulation of osteoclast differentiation by fibroblast growth factor 2: Stimulation of receptor activator of nuclear factor κ B ligand/osteoclast differentiation factor expression in osteoblasts and inhibition of macrophage colony-stimulating factor function in osteoclast precursors. *Journal of Bone & Mineral Research*, 16(11): 2074-2081, 2001
48. Sakai N., Tokunaga K., Yamazaki Y., Shida H., Sakata Y., Susami T., Takato T. and Uchinuma E. : Sequence analysis of fibroblast growth factor receptor 2 (FGFR2) in Japanese patients with craniosynostosis. *Journal of Craniofacial Surgery*, 12: 580-585, 2001
49. Nozaki T., Fujihara H., Kamada N., Ueda O., Takato T., Nakagama H., Sugimura T., M.J.A., Suzuki H., and Masutani M. : Hyperploidy of embryonic fibroblasts derived from *Parp-1* knockout mouse. *Proceeding of the Japan Academy*, 77B(6) : 121-124,2001
50. Jinhong Huang, Hamasaki H., Nakamoto T., Honda H., Hirai H., Saito M., Takato T., Sakai R. : Differential regulation of cell migration, actin stress fiber organization and cell transformation by functional domains of Cas *Journal of Biological Chemistry* 277(30): 27265-27272, 2002

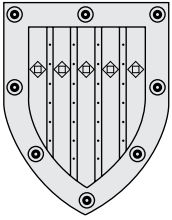

Department of Orthopaedic Surgery

Outline and Research Objectives

Our department was established in 1906 as the first department of orthopaedic surgery in Japan. Since then our efforts have been dedicated to responding to the needs of patients for orthopaedic care and to related research. We have pioneered handicapped children's care, developed new and innovative surgical techniques, and invented arthroscopy which is now used worldwide.

Our department seeks to elucidate the molecular and genetic backgrounds of bone and cartilage disorders including osteoporosis, osteoarthritis, and joint destruction in rheumatoid arthritis. To achieve this, we utilize the newest methodologies, and with the knowledge gained, we are working to develop groundbreaking treatments for these conditions, such as bone and cartilage regeneration. At the same time we are attempting to establish a non-invasive analyzing system to evaluate the mechanical property of the skeletal system and a computer-guided operating system to put to use our findings of the last half decade.

Faculty and Students

Professor and Chair	Kozo Nakamura, M.D., Ph.D. (1998-)
Associate Professor	Hiromi Oda, M.D., Ph.D. Yoshio Takatori, M.D., Ph.D.
Lecturer	Isao Ohnishi, M.D., Ph.D. Atsushi Seichi, M.D., Ph.D. Takahiro Goto, M.D., Ph.D. Hiroshi Kawaguchi, M.D., Ph.D. Hiroshi Okazaki, M.D., Ph.D.

Associate	12
Postdoctoral Fellow	1
Graduate student	25
Secretary	3

Past Research and Major Accomplishments

1. Regulation of anabolic and catabolic bone metabolism by fibroblast growth factor-2 (FGF-2)

We have had achieved notable advances in laboratory and clinical research on cytokines / growth factors in bone. Perhaps our most important contribution has been in defining the actions of FGF-2 on bone. We have reported the anabolic action of FGF-2 on bone formation using several physiological and pathological animal models of both rodents and primates. Our efforts in this area have led to studies of clinical application of FGF-2 to fracture healing and osteoporosis. The involvement of FGF-2 on bone resorption has also been investigated and this may possibly be involved in the joint destruction by rheumatoid arthritis.

2. Molecular mechanism of age-related bone loss (A novel aging suppressor gene: *klotho*)

Reverse genetic analysis revealed that mice deficient in the *klotho* gene exhibited bone loss with low turnover which is characteristic of human osteoporosis with aging. Using a forward genetic approach, we found that two polymorphisms at the human *klotho* locus are correlated with bone density in postmenopausal women, especially in their older years and independent of race, suggesting that the *klotho* gene may be involved in bone loss with aging.

3. Involvement of insulin signaling in bone anabolic action

Through clinical studies we found that the severity of ossification of the posterior longitudinal ligament of the spine (OPLL) is associated with insulin secretory response due to impairment of the response to insulin in its target tissues. The importance of insulin signaling in the anabolic bone metabolism was confirmed by reverse genetic approach on knock-out mice of the insulin receptor substrates IRS-1 and IRS-2, which are essential intracellular signaling molecules of insulin. It was shown that IRS-1 maintains bone turnover while IRS-2 is needed to maintain the predominance of bone formation over bone resorption; the integration of these two signalings causes a potent bone anabolic action by insulin.

4. Molecular mechanism of osteoclast differentiation in rheumatoid arthritis (RA)

Recent studies have revealed that a TNF- α superfamily cytokine, receptor activator of nuclear factor- κ B ligand (RANKL) plays a pivotal role in osteoclast differentiation and activation. We found that RANKL is

highly expressed in synovial fibroblasts obtained from RA patient synovial tissues, and critically implicated in the bone and joint destruction of RA.

5. Gene transfer to osteoclasts and gene therapy

We recently established a gene transduction system into mature osteoclasts using adenovirus vectors, and successfully regulated osteoclast function by introducing several genes that modulate the function and survival. Protooncogene product c-Src is a non-receptor type tyrosine kinase which is indispensable for osteoclast activation. The kinase activity of c-Src is regulated by another cytoplasmic tyrosine kinase Csk (C-terminal Src kinase). Introduction of *csk* gene into osteoclasts by the adenovirus vector completely disrupted the cytoskeletal organization of the cells, and strongly suppressed their bone-resorbing activity. Using the adenovirus vector-mediated gene transduction system, we also found that the Ras-ERK pathway is critical for the survival of osteoclasts.

6. Gene therapy of arthritic joint destruction using adenovirus vectors

Adenovirus vectors are effective not only *in vitro* but also *in vivo* gene delivery into osteoclasts. Local injection of Csk adenovirus reduced IL-1-induced bone destruction in calvarial bone. When injected into arthritic joints, adenovirus vectors efficiently transduce synovial fibroblasts as well as osteoclasts. Csk adenovirus inhibited proliferation of synovial fibroblasts and their proinflammatory cytokine production *in vitro*, and intraarticular injection of the virus significantly ameliorated joint destruction in adjuvant arthritis rats. These results demonstrate that the adenovirus vector system is a good therapeutic approach to arthritic bone destruction.

We also found that adenovirus vector-mediated *csk* gene transduction suppressed the tumor metastasis and constitutively active MEK1 gene recovered the paraplegia after spinal cord injury.

7. Regulation of bone homeostasis by RANKL and IFNs (interferons)

Investigation of the regulation of osteoclastogenesis by the immune system showed the critical involvement of IFNs in bone metabolism. Mice deficient in IFNGR1 (IFN- γ receptor) exhibited more severe bone damage accompanied by enhanced osteoclastogenesis when stimulated with lipopolysaccharide (LPS). Activated T cells strongly inhibited osteoclastogenesis via IFN- γ , and IFN- γ interfered with RANKL signaling by inhibiting expression of TRAF6 (TNF receptor associated factor 6). Thus, IFN- γ protects against T cell-mediated inflammatory bone loss. In contrast, mice deficient in IFNAR1 (IFN- α receptor, one of IFN- α/β receptor components) spontaneously develop

marked osteopenia accompanied by enhanced osteoclastogenesis. RANKL induces IFN- β gene in osteoclast precursor cells and IFN- β inhibits the differentiation by interfering with the RANKL-induced expression of c-Fos, an essential transcription factor for osteoclastogenesis. Thus, IFN- β acts as a negative feedback regulator of RANKL-induced osteoclastogenesis in physiological bone remodeling. Thus, IFN- γ and IFN- β , both of which play pivotal roles in the immune system, also function in the negative regulation of RANKL signaling via distinct mechanisms.

Current Research

1. Reverse and forward genetic approach to the pathophysiology of osteoarthritis

Osteoarthritis, a major skeletal disorder, is considered a collective result of heterogeneous etiopathologic factors affecting cartilage. We actually identified two novel genes associated with chondrocyte differentiation and degradation: *cystacin10* and *cgk2*. To further determine the molecular background of the disorder, we created an osteoarthritis model in mice by cutting ligaments in and around the knee joint. Several knock-out or transgenic mice were subjected to an operation to learn the involvement of the manipulated gene in the disorder. In addition, as a forward genetic approach, we are in the middle of the genome-wide association study on the human knee and hip osteoarthritis.

2. Genome-wide association study of OPLL

Based on a reverse genetic study, we have found that nucleotide pyrophosphate (*Npps*) gene is related to the incidence and progression of OPLL. Since OPLL is a polygenic disease, we are conducting a genome-wide association study of the condition in which more than 100,000 single nucleotide polymorphisms (SNPs) will be evaluated for their association with susceptibility to and severity of OPLL. DNA samples are now being collected in a national project headed by the presenter.

3. Molecular mechanism of age-related bone loss (PPAR- γ)

Considering that osteoblasts and adipocytes share origins in bone marrow mesenchymal cells, and that human aging is associated with a reciprocal increase in adipocytes and a decrease in osteoblasts in bone marrow, PPAR- γ may be clinically involved in the pathophysiology of bone loss with aging as a suppressor of osteoblastogenesis. To identify the role of endogenous PPAR- γ *in vivo*, we examined the bone of PPAR- γ hetero knock-out mice, and found that bone mass in these mice increases with stimulation of

osteoblastogenesis from bone marrow progenitors without affecting mature osteoblasts or osteoclast-lineage cells. The forward genetic approach beginning with the screening of polymorphisms of the human PPAR- γ gene is now underway.

4. Cloning master gene(s) of osteoclast differentiation

In an attempt to identify gene(s) that regulate osteoclast differentiation, we are utilizing a molecular indexing technique, and have found several genes that regulate osteoclast-specific promoter activity. We are currently working on the function of the genes in osteoclasts.

5. Treating arthritic bone destruction by targeting RANKL/RANK pathways

As mentioned above, RANKL/RANK pathways are critically involved in pathological bone resorption, and therefore can be a good therapeutic target. The effect of osteoprotegerin (OPG), a natural inhibitor of RANKL, on pathological bone resorption is currently being examined. In a preliminary study, local injection of recombinant human OPG into arthritic joints effectively ameliorated the bone destruction in adjuvant arthritis rats.

We are also trying to establish a technology of RANKL vaccination therapy, in which modified RANKL is utilized to induce anti-RANKL self-antibody, which has neutralizing activity against self RANKL, and therefore has a therapeutic effect on bone destruction.

6. Molecular mechanism of osteoclast apoptosis

Osteoclasts are terminally differentiated non-proliferating cells with a very short life span. We are now trying to identify molecule(s) that induce osteoclast apoptosis, and have found that a pro-apoptotic Bcl-2 family member Bim plays an essential role. In our studies on the role of small GTP-binding proteins on osteoclast survival, Rac1 transduction was found to prolong the survival.

7. Gene therapy of arthritic bone resorption

We recently found that adenovirus vectors carrying dominant negative Ras gene (AxRas^{DN}) strongly suppressed the proliferation and proinflammatory cytokine production of synovial fibroblasts. We are currently investigating the effect of AxRas^{DN} on arthritic bone destruction, and in a preliminary study, found that this virus could significantly suppress joint destruction in adjuvant arthritis rats.

8. Evaluation of mechanical properties of skeletal system

A system of analyzing mechanical properties of a

skeletal system has been required to clinically evaluate the efficacy of osteoporosis treatment and to decide on a method or term of fracture treatment. We are developing a non-invasive analyzing system *in vivo* using CT based finite element analyses which can make it possible to predict fracture load and location, which is based on the maximum principal stress failure theory.

9. Investigation of adult neural progenitors as a new therapeutic tool for damaged spinal cord

Seeking a therapeutic tool useful in the treatment of the damaged spinal cord, we have investigated adult endogenous neural progenitors, including stem cells. Their widespread occurrence and proliferation in response to injury have been demonstrated. One of their regulatory mechanisms *in vivo*, Notch signaling, is suggested from their molecular property. Thus, genetic manipulations of endogenous progenitors *in situ* may enable the recruitment of their latent regenerative potential. Further advances of such strategies may make possible significant structural repair of the damaged spinal cord.

10. Development of a joint prosthesis with less loosening

We are developing a new type of hip joint prosthesis whose surface is covered with a synthetic material, methacryloyloxyethyl phosphorylcholine (MPC), resembling the human membrane phospholipid. We have confirmed that the prosthesis successfully decreases the friction index up to 1/5 of the conventional one. Due to the similarity of the material to living membrane, this may possibly elicit a less rejective response causing loosening. This prosthesis will improve the outcome of joint replacement surgery and lead to a new era in osteoarthritis treatment.

11. Navigation robot for minimally invasive surgery

Image-guided surgery is gradually spreading with the advancement of pre-surgical simulation using X-ray CT or MR images to achieve minimally invasive and safer surgical procedures. In cervical bone fixation surgery, highly accurate positioning accuracy is required during drilling to avoid injuring the spinal cord and major blood vessels. However, when using an image-guided navigation system, we encounter difficulties in obtaining accurate "registration" between the navigation results and a device such as a needle, screw or drill; these difficulties arise mainly either from a surgeon's tremor or complicated spatial orientation relations. To overcome these problems, we have developed the first prototype of a simple robot having two degrees-of-freedom (2-DOF), which controls the orientation of a device. The characteristics of

the robot, low DOF, restricted range of movement, and light weight, make it possible to use it in a clinical setting.

Future Prospects

1. Bone and cartilage regeneration

We plan to introduce a new type of bone and cartilage regeneration based not only on tissue engineering, but also on molecular and genetic biology. Endochondral bone development is characterized by a process in which a cartilage mold is replaced by bone. During this process, cartilage induces bone in the adjacent tissue. We have found that a subgroup of cartilage containing hypertrophic chondrocytes plays an essential role in this induction. In addition, these chondrocytes induce vascular invasion. Based on these two findings, we came up with a new strategy to regenerate bone, which is a relatively well vascularized organ. Instead of separately regenerating bone and vasculature and subsequently combining and transplanting them to create viable bone tissue, we have proposed to graft hypertrophic chondrocytes to have them induce both bone and vasculature simultaneously. To realize this unique strategy, we are trying to improve methods to derive chondrocytes from various stem cells, differentiate them further into hypertrophic chondrocytes, and combine them with appropriate scaffolds to create new osteogenic-angiogenic biomaterial.

2. Control of pathological bone destruction

In the future, we will be able to establish novel treatments for pathological bone destruction, and the RANKL/RANK pathway can be a good therapeutic target. RANKL vaccination technology is a promising preventive therapy. By identifying the genes and signal transduction pathways that regulate osteoclast differentiation, activation, and survival, we will be able to regulate bone resorption much more precisely and meticulously. Adenovirus vector-mediated gene transduction will be a good means of gene therapy targeting osteoclasts by modulating intracellular signals.

3. Surgical navigation system with intuitive three-dimensional display and navigation robot

We are developing a new surgical navigation system which superimposes the real, intuitive three-dimensional (3-D) image of the patient's internal structure on the patient's body, and helps surgeons to perform surgery. The system consists of a personal computer, a lens array, a supporting stage, a liquid crystal display and a half-silvered mirror. The 3-D images are generated by real-time computer-generated integral photography, and superimposed on the patient's body via a half-silvered mirror, as if they were seen through the body. Because of the simplicity and the intuitiveness of the navigation image, this system will become applicable for clinical use in the near future in combination with the navigation robot system described above.

Research Grants (Figure 1)

Figure 1 Research Grants to the Dept. of Orthop. Surg., Univ. of Tokyo (1998-2002 (September))

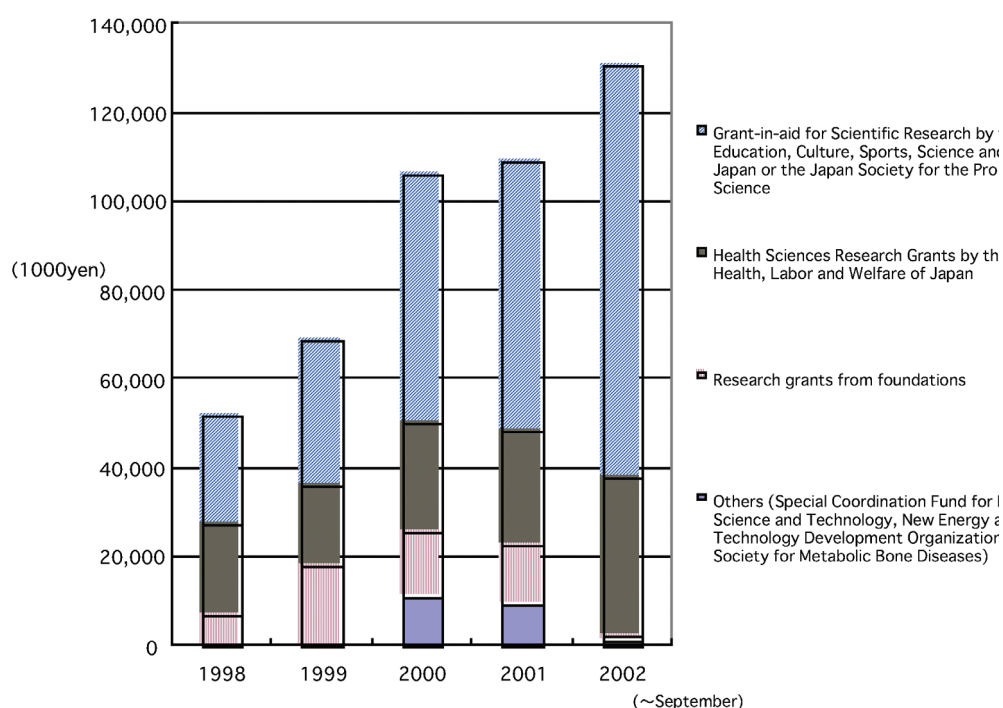

Select Publications (50)

1. Nakamura K, Kurokawa T, Aoyama I, Hanada K, Tamura M, Kawaguchi H: Stimulation of bone formation by intraosseous application of basic fibroblast growth factor in ovariectomized rats. *Int Orthop* 22: 49-54, 1998
2. Tanaka S, Takahashi T, Takayanagi H, Miyazaki T, Oda H, Nakamura K, Hirai H, Kurokawa T: Modulation of osteoclast function by adenovirus vector-induced epidermal growth factor receptor. *J Bone Miner Res* 13: 1714-1720, 1998
3. Nakamura K, Matsushita T, Mamada K, Okazaki H, Ou W, Okuma Y, Kurokawa T: Changes of callus diameter during axial loading and after fixator removal in leg lengthening. *Arch Orthop Trauma Surg* 117: 464-467, 1998
4. Kato T, Kawaguchi H, Hanada K, Aoyama I, Hiyama Y, Kuzutani T, Tamura M, Kurokawa T, Nakamura K: Single local injection of recombinant fibroblast growth factor-2 stimulates healing of segmental bone defects in rabbits. *J Orthop Res* 16: 654-659, 1998
5. Okazaki H, Kurokawa T, Nakamura K, Matsushita T, Mamada K, Kawaguchi H: Stimulation of bone formation by recombinant fibroblast growth factor-2 in callotasis bone lengthening of rabbits. *Calcif Tissue Int* 64: 542-546, 1999
6. Nakamura I, Ikegawa S, Okawa A, Okuda S, Koshizuka Y, Kawaguchi H, Nakamura K, Koyama T, Goto S, Toguchida J, Matsushita M, Ochi T, Takaoka K, Nakamura Y: Association of the human NPPS gene with ossification of the posterior longitudinal ligament of the spine (OPLL). *Hum Genet* 104: 492-497, 1999
7. Manabe N, Oda H, Nakamura K, Kuga Y, Uchida S, Kawaguchi H: Involvement of fibroblast growth factor-2 in joint destruction of rheumatoid arthritis patients. *Rheumatology* 38: 714-720, 1999
8. Takayanagi H, Juji T, Miyazaki T, Iizuka H, Takahashi T, Isshiki M, Okada M, Tanaka Y, Koshihara Y, Oda H, Kurokawa T, Nakamura K, Tanaka S: Suppression of arthritic bone destruction by adenovirus-mediated csk gene transfer to synoviocytes and osteoclasts. *J Clin Invest* 104: 137-146, 1999
9. Kawaguchi H, Manabe N, Miyaura C, Chikuda H, Nakamura K, Kuro-o M: Independent impairment of osteoblast and osteoclast differentiation in *klotho* mouse exhibiting low-turnover osteopenia. *J Clin Invest* 104: 229-237, 1999
10. Nishikawa T, Ogawa S, Kogita K, Manabe N, Katsumata T, Nakamura K, Kawaguchi H: Additive effects of combined treatment with etidronate and alfacalcidol on bone mass and mechanical properties in ovariectomized rats. *Bone* 27: 647-654, 2000
11. Takayanagi H, Iizuka H, Juji T, Nakagawa T, Yamamoto A, Miyazaki T, Koshihara Y, Oda H, Nakamura K, Tanaka S: Involvement of receptor activator of nuclear factor κ B ligand/osteoclast differentiation factor in osteoclastogenesis from synoviocytes in rheumatoid arthritis. *Arthritis Rheum* 43: 259-269, 2000
12. Kawaguchi H, Chikazu D, Nakamura K, Kumegawa M, Hakeda Y: Direct and indirect actions of fibroblast growth factor-2 on osteoclastic bone resorption in cultures. *J Bone Miner Res* 15: 466-473, 2000
13. Ogata N, Chikazu D, Kubota N, Terauchi Y, Tobe K, Azuma Y, Ohta T, Kadowaki T, Nakamura K, Kawaguchi H: Insulin receptor substrate-1 in osteoblast is indispensable for maintaining bone turnover. *J Clin Invest* 105: 935-943, 2000
14. Takayanagi H, Ogasawara K, Hida S, Chiba T, Murata S, Sato K, Takaoka A, Yokochi T, Oda H, Tanaka K, Nakamura K, Taniguchi T: T cell-mediated regulation of osteoclastogenesis by signaling cross-talk between RANKL and IFN- γ . *Nature* 40: 600-605, 2000
15. Nakagawa T, Tanaka S, Suzuki T, Takayanagi H, Miyazaki T, Nakamura K, Tsuruo T: Overexpression of the *csk* gene suppresses tumor metastasis in vivo. *Int J Cancer* 88: 384-391, 2000
16. Miyazaki T, Takayanagi H, Isshiki M, Takahashi T, Okada M, Fukui Y, Oda H, Nakamura K, Hirai H, Kurokawa T, Tanaka S: In vitro and in vivo suppression of osteoclast function by adenovirus vector-induced *csk* gene. *J Bone Miner Res* 15: 41-51, 2000
17. Miyazaki T, Katagiri H, Kanegae Y, Takayanagi H, Sawada Y, Yamamoto A, Pando MP, Asano T, Verma IM, Oda H, Nakamura K, Tanaka S: Reciprocal role of ERK and NF- κ B pathways in survival and activation of osteoclasts. *J Cell Biol* 148: 333-342, 2000
18. Miura T, Tanaka S, Seichi A, Arai M, Goto T, Katagiri H, Asano T, Oda H, Nakamura K: Partial functional recovery of paraplegic rat by adenovirus-mediated gene delivery of constitutively active MEK1. *Exp Neurol* 166: 115-126, 2000
19. Kawaguchi H, Manabe N, Chikuda H, Nakamura K, Kuro-o K: Cellular and molecular mechanism of low-turnover osteopenia in the *klotho*-deficient mouse. *Cell Mol Life Sci* 57: 731-737, 2000
20. Ohtsuka T, Ohnishi I, Nakamura K, Takamoto S: New instrumentation for video-assisted anterior spine release. *Surg Endosc* 14: 682-684, 2000
21. Manabe N, Kawaguchi H, Chikuda H, Miyaura C, Inada M, Nagai R, Nabeshima Y, Nakamura K, Sinclair AM, Scheuermann RH, Kuro-o M: Connection between B lymphocyte and osteoclast differentiation pathways. *J Immunol* 167: 2625-31, 2001
22. Yamamoto N, Yamamoto S, Inagaki F, Kawaichi M, Fukamizu A, Kishi N, Matsuno K, Nakamura K, Weinmaster G, Okano H, Nakafuku M: Role of Deltex-1 as a transcriptional regulator downstream of the Notch receptor. *J Biol Chem* 276: 45031-45040, 2001
23. Yamamoto S, Nagano M, Sugimori M, Kosako H, Nakatomi H, Yamamoto N, Takebayashi H, Nabeshima Y, Kitamura T, Weinmaster G, Nakamura K, Nakafuku M: Transcription factor expression and Notch-dependent regulation of neural progenitors in

- the adult rat spinal cord. *J Neurosci* 21: 9814-9823, 2001
24. Yamamoto S, Yamamoto N, Kitamura T, Nakamura K, Nakafuku M: Proliferation of parenchymal neural progenitors in response to injury in the adult rat spinal cord. *Exp Neurol* 172: 115-127, 2001
 25. Ikeda T, Mabuchi A, Fukuda A, Hiraoka H, Kawakami A, Yamamoto S, Machida H, Takatori Y, Kawaguchi H, Nakamura K, Ikegawa S: Identification of sequence polymorphisms in two sulfation-related genes, PAPSS2 and SLC26A2, and an association analysis with knee osteoarthritis. *J Hum Genet* 46: 538-543, 2001
 26. Kawaguchi H, Nakamura K, Tabata Y, Ikada Y, Aoyama I, Anzai J, Nakamura T, Hiyama Y, Tamura M: Acceleration of fracture healing in non-human primates by fibroblast growth factor-2. *J Clin Endocrinol Metab* 86: 875-880, 2001
 27. Koshizuka Y, Ikegawa S, Sano M, Nakamura K, Nakamura Y: Isolation of novel mouse genes associated with ectopic ossification by differential display method using *ttw*, a mouse model for ectopic ossification. *Cytogenet Cell Genet* 94: 163-168, 2001
 28. Seichi A, Takeshita K, Ohnishi I, Kawaguchi H, Akune T, Anamizu Y, Kitagawa T, Nakamura K: Long-term results of double-door laminoplasty for cervical stenotic myelopathy. *Spine* 26: 479-487, 2001
 29. Ogata N, Shiraki M, Koshizuka Y, Nakamura K, Kawaguchi H: A polymorphic variant at the Werner helicase (*WRN*) gene is associated with bone density, but not spondylosis, in postmenopausal women. *J Bone Miner Metab* 19: 296-301, 2001
 30. Nakajima S, Nakamura K, Masamura K, Sakuma I, Dohi T: Three-dimensional medical imaging display with computer-generated integral photography. *Comput Med Imaging Graph* 25: 235-241, 2001
 31. Nakajima S, Nakamura K, Masamura K, Sakuma I, Dohi T: Development of a tracking method for image analysis of time-lapse deformation of trabecular structure in a human bone. *Comput Med Imaging Graph* 25: 443-448, 2001
 32. Koshizuka Y, Ikegawa S, Sano M, Nakamura K, Nakamura Y: Isolation, characterization, and mapping of the mouse and human *WDR8* genes, members of a novel WD-repeat gene family. *Genomics* 72: 252-259, 2001
 33. Nishimura G, Manabe N, Kosaki K, Haga N, Ohashi H, Nakamura K, Ikegawa S: Spondylar dysplasia in Type X collagenopathy. *Pediatr Radiol* 31: 76-80, 2001
 34. Akune T, Ogata N, Seichi A, Ohnishi I, Nakamura K, Kawaguchi H: Insulin secretory response is positively associated with the extent of ossification of the posterior longitudinal ligament of the spine. *J Bone Joint Surg Am* 83-A: 1537-1544, 2001
 35. Mabuchi A, Ikeda T, Fukuda A, Koshizuka Y, Hiraoka H, Miyoshi K, Haga N, Kawaguchi H, Kawakami A, Yamamoto S, Takatori Y, Nakamura K, Ikegawa S: Identification of sequence polymorphisms of the COMP (cartilage oligomeric matrix protein) gene and association study in osteoarthritis of the knee and hip joints. *J Hum Genet* 46: 456-462, 2001
 36. Mabuchi A, Haga N, Ikeda T, Manabe N, Ohashi H, Takatori Y, Nakamura K, Ikegawa S: Novel mutation in exon 18 of the cartilage oligomeric matrix protein gene causes a severe pseudoachondroplasia. *Am J Med Genet* 104: 135-139, 2001
 37. Fukui N, Nakajima K, Tashiro T, Oda H, Nakamura K: Neutralization of fibroblast growth factor-2 reduces intraarticular adhesions. *Clin Orthop* 383: 250-258, 2001
 38. Fukui N, Fukuda A, Kojima K, Nakajima K, Oda H, Nakamura K: Suppression of fibrous adhesion by proteoglycan decorin. *J Orthop Res* 19: 456-462, 2001
 39. Ikeda T, Mabuchi A, Fukuda A, Kawakami A, Yamada R, Yamamoto S, Miyoshi K, Haga Y, Hiraoka H, Takatori Y, Kawaguchi H, Nakamura K, Ikegawa S: Association analysis of single nucleotide polymorphisms in cartilage-specific collagen genes with knee and hip osteoarthritis in the Japanese population. *J Bone Miner Res* 17: 1290-1296, 2002
 40. Yamamoto A, Miyazaki T, Kadono Y, Takayanagi H, Miura T, Nishina H, Katada T, Wakabayashi K, Oda H, Nakamura K, Tanaka S: Possible involvement of I κ B kinase 2 and MKK7 in osteoclastogenesis induced by receptor activator of nuclear factor κ B ligand. *J Bone Miner Res* 17: 612-621, 2002
 41. Takayanagi H, Kim S, Matsuo K, Suzuki H, Suzuki T, Sato K, Yokochi T, Oda H, Nakamura K, Ida N, Wagner EF, Taniguchi T: RANKL maintains bone homeostasis through c-Fos-dependent induction of interferon- β . *Nature* 416: 744-749, 2002
 42. Matsuda K, Yoshida K, Taya Y, Nakamura K, Nakamura Y, Arakawa H: p53AIP1 regulates the mitochondrial apoptotic pathway. *Cancer Res* 62: 2883-2889, 2002
 43. Koshizuka Y, Kawaguchi H, Ogata N, Ikeda T, Mabuchi A, Seichi A, Nakamura Y, Nakamura K, Ikegawa S: Nucleotide pyrophosphatase gene polymorphism associated with ossification of the posterior longitudinal ligament of the spine. *J Bone Miner Res* 17: 138-144, 2002
 44. Shimoaka T, Ogasawara T, Yonamine A, Chikazu D, Hirota H, Nakamura K, Itoh N, Kawaguchi H: Regulation of osteoblast, chondrocyte, and osteoclast functions by fibroblast growth factor (FGF)-18 in comparison with FGF-2 and FGF-10. *J Biol Chem* 277: 7493-7500, 2002
 45. Ogata N, Matsumura Y, Shiraki M, Kawano K, Koshizuka Y, Hosoi T, Nakamura K, Kuro-o M, Kawaguchi H: Association of *klotho* gene polymorphism with bone density and spondylosis of the lumbar spine in postmenopausal women. *Bone* 31: 37-42, 2002
 46. Ogata N, Koshizuka Y, Miura T, Iwasaki M, Hosoi T, Shiraki M, Seichi A, Nakamura K, Kawaguchi H: Association of bone metabolism regulatory factor gene polymorphisms with susceptibility to ossifica-

- tion of the posterior longitudinal ligament of the spine and its severity. *Spine*. 27: 1765-1771, 2002
47. Kawano K, Ogata N, Chiano M, Molloy H, Kleyn P, Spector TD, Uchida M, Hosoi T, Suzuki T, Orimo H, Inoue S, Nabeshima Y, Nakamura K, Kuro-o M, Kawaguchi H: Klotho gene polymorphisms associated with bone density of aged postmenopausal women. *J Bone Miner Res* (in press)
 48. Ikeda T, Junwei Z, Chano T, Mabuchi A, Fukuda A, Kawaguchi H, Nakamura K, Ikegawa S: Identification and characterization of the human long form of Sox5 (L-SOX5) gene. *Gene* (in press)
 49. Kotani H, Kawaguchi H, Ueno S, Shimoaka T, Iwasaka M, Ozawa H, Nakamura K, Hoshi K: Strong static magnetic field stimulates bone formation to a definite orientation in vitro and in vivo. *J Bone Miner Res* (in press)
 50. Akune T, Ogata N, Hoshi K, Kubota N, Terauchi Y, Tobe K, Takagi H, Azuma Y, Kadowaki T, Nakamura K, Kawaguchi H: Insulin receptor substrate-2 maintains predominance of anabolic function over catabolic function of osteoblasts. *J Cell Biol* (in press)

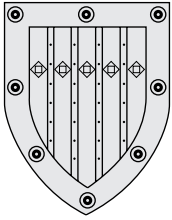

Department of Ophthalmology

Outline and Research Objectives

The Department of Ophthalmology University of Tokyo was established in 1889. Since then, over a century, our department has played a crucial role as a pioneer in every aspects of ophthalmology in Japan and delivered a lot of international leaders in both clinical and research fields of ophthalmology. The chairman Jujiro Komoto (1889-1922) introduced Western ophthalmology into Japan and established the basics in Japanese ophthalmologic society. The chairman Shinobu Ishihara (1922-1940) developed Ishihara test plate for color blindness, which is still a world-wide golden standard as a screening examination for color blindness. The chairman Yoshiharu Shoji (1940-1949) investigated on the pathogenesis of cataract and the chairman Hagiwara (1915-1964) conducted basic and clinical research on Behcet's disease, the cornea, and the extra-ocular muscles. The chairman Shinichi Shikano (1964-1971) performed research on Behcet's disease and autonomic nervous system in the eye. The chairman Saiichi Mishima (1971-1987) controlled comprehensive research on the physiology of the cornea, ocular pharmacology, and surgical biology, and served as a chief organizer of international congress of ophthalmology held in Kyoto in 1978. The chairman Kanjiro Masuda (1987-1997) conducted research on the pathogenesis and therapy of uveitis. The chairman Makoto Araie (1997-present) has organized thorough research on ocular pharmacology, ocular blood-flow, and clinical and basic aspects of glaucoma and cornea transplantation.

Faculties and Students:

Professor and Chair	Makoto Araie, MD., Ph.D. (1997~)
Associate Professor	Hidetoshi Kawashima, MD., Ph.D. Goji Tomita, MD., Ph.D.
Lecturer	Yasuyuki Suzuki, MD., Ph.D. Yasuhiro Tamaki, MD., Ph.D. Satoru Kato, MD., Ph.D. Miyuki Nagahara, MD., Ph.D.
Associate	10
Postdoctoral Fellow	1
Secretary	2

Past Researches and Major accomplishments

1) Evaluation of important parameters of ocular physiology by means of in vivo fluorophotometry or in vivo measurements of protein concentration in the aqueous humor:

Effects of various anti-glaucoma eye drops on both the aqueous flow rate and blood-aqueous-barrier (BAB) permeability were first and quantitatively determined in human eyes and anti-inflammatory effects of topical NSAID were first quantitatively determined in patients undergoing cataract surgery. Further, a method to non-invasively monitor the aqueous production reducing effects of anti-glaucoma drugs in human eyes or toxic effects of intra-ocular irrigating

solution in animal eyes have been first developed. The techniques thus establish were used in developing a new anti-glaucoma drug, which is now marketed.

2) Study of cornea:

Permeability to the cornea is the rate-limiting factor for intra-ocular penetration of topically instilled drugs. A pre-existing method for in vivo determination of corneal endothelial (CE) permeability was improved so that status of its barrier function can be estimated more systematically. A new in-vitro method for quantitative evaluation of CE permeability was established, which was world-wide used for comparing safety of various intra-ocular irrigating solutions, and the lowest Ca^{2+} concentration needed to maintain the CE integrity was first determined. Further, molecular biological features of corneal endothelial cells were investigated and the above studies are followed by the present investigation of regenerative medicine of corneal graft for corneal transplantation.

3) Study of ocular pharmacokinetics:

Using the 2-compartment computer model, ocular pharmacokinetics of topically instilled beta-blockers, one of the most important anti-glaucoma drug, were studied and binding of topically instilled beta-blockers to uveal pigment and its clinical implication were first

demonstrated. Trans-corneal and intravitreal kinetics of fluorophores were studied to determine factors to facilitate intra-ocular penetration of topically instilled and systemically administered drugs.

4) Clinical study of glaucoma:

Glaucoma is the leading cause of blindness in developed countries and open angle glaucoma represents 75% of all glaucomas in Japan. Surgical techniques of glaucoma were improved by introducing antimetabolites and basic features of adjunctive use of anti metabolites investigated. By computer analysis of visual field results, IOP-dependent damages in the visual field were elucidated, optimal sectorization of test points determined and it was also found that IOP is a risk factor for progression also in normal tension glaucoma. And, effects of glaucoma surgery or calcium antagonists on the visual field progression in normal tension glaucoma were first qualitatively determined. New image analysis techniques, psychophysical methods and new anti-glaucoma eye drops were evaluated and one anti-glaucoma eye drop could be successfully developed and marketed.

5) Basic study of glaucoma:

Clinical study of glaucoma demonstrated that IOP is not the only factor contributing to progression of glaucoma, which lead to experimental studies on neuroprotection. Conditioned medium from human amniotic epithelial cells was first found to have neurotrophic effects on cultured neurons including retinal ganglion cells (RGCs) and interaction between retinal glial cells or NO and isolated RGCs were determined. Novel gene mutation in Japanese glaucoma patients was found and MYOC, one of glaucoma genes, was cloned in the bovine eye.

6) Study of ocular blood flow:

Clinical studies of glaucoma revealed that local circulation is also involved in progression of glaucoma. Apparatuses which can non-invasively estimate the blood flow in the iris, retina, choroids or optic nerve head utilizing laser speckle phenomenon in living eyes were constructed, establishing the laser speckle method as an in-vivo, non-invasive peripheral blood flow measurement method which can be applied in human subjects. Using this method, effects of calcium antagonists, topical eye drops or surgical procedures on ocular circulation of various ocular tissues could be first systemically studied. It was first found that the ocular tissue most effectively affected is different depending on the Ca²⁺-antagonist used (nicardipine selectively affects choroidal circulation, lomerizine ONH circulation etc). The important new finding obtained by the ocular blood studies was, topically instilled drugs can influence the circulation in the pos-

terior parts of the eye through their direct penetration to the posterior part of the eye, which have been considered to be impossible. This finding not only has great clinical implication in ocular therapeutics, but also prompted the current study to confirm that topically instilled drugs penetrate to the posterior retina, choroids or retrobulbar tissues at pharmacological concentrations.

Current Researches and Future Prospects.

1) Study of Cornea:

To cope with very limited supply of donor corneas and allograft rejection in corneal transplantation, the reconstruction of artificial cornea has been attempted using the tissue engineering technology. A method to culture human corneal endothelial cells (HCEC) has been first established and, using cultured HCECs and human corneal stroma the cornea could be successfully reconstructed. Thus reconstructed cornea has 70-80% of cell density, pump function and barrier function of normal HCECs. The reconstructed cornea transplanted to rabbit eye stayed transparent during postoperative 6 months, showing transplanted HCEC normally functioning. Animal corneal stroma as a carrier of cultured HCECs is being investigated. The cornea reconstructed with porcine corneal stroma and HCECs showed average cell density pump function of about 60-70% of normal HCECs and bone marrow cells injected into rat anterior chamber were found to transform into CE-like cells, suggesting that self immature cells can transform into CEs. Possibility of utilizing cultured HCEC from fetus is now investigated. Antigen-specific T cell activation is a critical step in the rejection of transplanted allografts. To activate T cells, two kinds of signal are necessary: signal mediated by T cell receptor (TCR)/CD3 complex and the costimulatory signal by cell surface adhesion molecules such as CD80/86 and ICAM-1. As novel therapies for rejection after corneal transplantation, the feasibility of anti-CD80/86 antibodies is being investigated using murine corneal transplantation model with a complete mismatch at major and minor histocompatibility. Clinical usage of reconstructed cornea, first in high-risk corneal transplantation cases, is planned in 5 years, to resolve very limited supply of donor corneas in Japan. By incorporating gene technology, grafts much better functioning with much less chance to be rejected than the donor cornea may be constructed. To reduce allograft rejection, therapy with anti-CD 80/86 antibodies and chemokine receptor antagonist such as CCRI antagonist, which is also involved in induction of rejection, may be also possible.

2) Study of ocular pharmacokinetics:

Our new finding suggesting penetration of topically instilled drug to the posterior parts of the eye at pharmacological concentrations will be a breakthrough in medical treatment of diseases of posterior parts of the eye such as the retinal, choroidal or optic nerve disorders. Whole-head autoradiography and a new method of isolation of posterior ocular tissues are now being carried out and confirmed the above findings. Factors and routes contributing to the posterior penetration of instilled drugs will be elucidated, and systemically safe, local treatment of retinal, choroidal or optic nerve disorders is to be developed.

3) Clinical study of glaucoma:

As one of the three chief investigators, Makoto Araie conducted an epidemiological study of glaucoma and related ocular diseases in Tajimi area and now is analyzing the obtained results as a chief of data analysis committee. This is the first ophthalmological epidemiological study carried out in mongoloids and its result will have a great impact in the field of ophthalmology. Several longitudinal, some of them randomized and prospective, studies are being conducted by Makoto Araie as a chief investigator a) A 3-year prospective, randomized, multi-centered and comparative study of nipradilol and timolol on the progression of normal tension glaucoma. The result of this study will first elucidate if non-IOP dependent risk factors of glaucoma can be treated by topical drugs or not, and if a positive result is obtained, it will be a great breakthrough in the medical treatment of glaucoma. b) The multi-centered, randomized, placebo-controlled study on the effects lomerizine, a Ca^{2+} -blocker, on the retinal blood flow is the first to study if retinal blood flow can be selectively increased by systemically safe oral Ca^{2+} -antagonis, lomerizine, and if a positive result is obtained, it will be a breakthrough in the medical treatment of retinal diseases. Other longitudinal or cross-sectional studies now ongoing includes disk bleeding study to investigate whether myopic-type disc is associated less disc bleeding but more progression of damage as compared with non-myopic type disc, advanced stage glaucoma study where disability in daily life in the late stage of the disease is prospectively questioned, frequency doubling technology visual field study where this new psychophysical test is prospectively evaluated from view point of early detection of glaucoma progression and scanning laser ophthalmoscopy study where morphometry of the optic disc in Japanese patients is quantitatively estimated on multi-center-based protocol, development of visual disability questionnaire designed to evaluate visual disability in Japanese glaucoma patients who vertically read and write, analysis of filtering bleb characteristics after

trabeculectomy in Japanese patients to find contributing factors to the late stage bleb-related complications, the most vision-threatening complication of glaucoma surgery. The result obtained from the above studies in future will shed new light on the diagnosis, follow-up, treatment and rehabilitation of glaucoma, the second leading cause of blindness in Japan, of which prevalence in adults was found to be as high as 5% (unpublished result of the above mentioned Tajimi Study).

4) Basic study of glaucoma:

Makoto Araie is serving as a chairman of Glaucoma Optic Neuropathy Study Group and established monkey glaucoma model is used to study how glaucomatous damaging processes impair the optic nerve head (ONH) structure, ONH circulation and neural functions (visual field, receptor field of neurons in lateral geniculate body, etc) and how the potential drugs can modify them, which is impossible to study in humans. ONH is the tissue primarily involved in glaucomatous damage and ONH damage results in loss of retinal ganglion cells in retina. Using established system of culture of isolated retinal ganglion cells and isolated Müller cells, factors, affecting survival of these cells, including therapeutic agents, are now intensively studied. Mammalian retina is composed of seven major cell types, Müller glia, and six neural cell types, retinal ganglion cell (RGC), bipolar cell, horizontal cell, amacrine cell, rod and cone photoreceptor cell. Unlike amphibian or fish, adult mammalian retina has been considered to be devoid of stem or progenitor cells and that substantial regeneration dose not take place.

However, a recent study has unexpectedly demonstrated the presence of retinal stem cells in adult mice, suggesting the possibility that these cells can be utilized as a potential cell source of transplantation therapy for damaged retinal cells including RGCs. Animal model is pre-requisite for the realization of the transplantation therapy, and rabbit is one of the most suitable animals because of its relatively large-sized eyes, easiness in handling and reasonable price. Method to isolate retinal stem cells from ciliary epithelium using neurosphere-forming assay has been established not only in mice but also rabbits and monkeys. Ongoing studies address factors involved in differentiation of retinal stem cells and how these cells can be utilized as cell source of transplantation therapy of retinal degenerative disorders including glaucoma. In culturing isolated RGCs and retinal stem cells, and in providing substrate for transplantation, human amniotic epithelial cells and our experience on them should be of considerable use.

5) Study of Ocular blood flow:

In addition to the laser speckle method that were

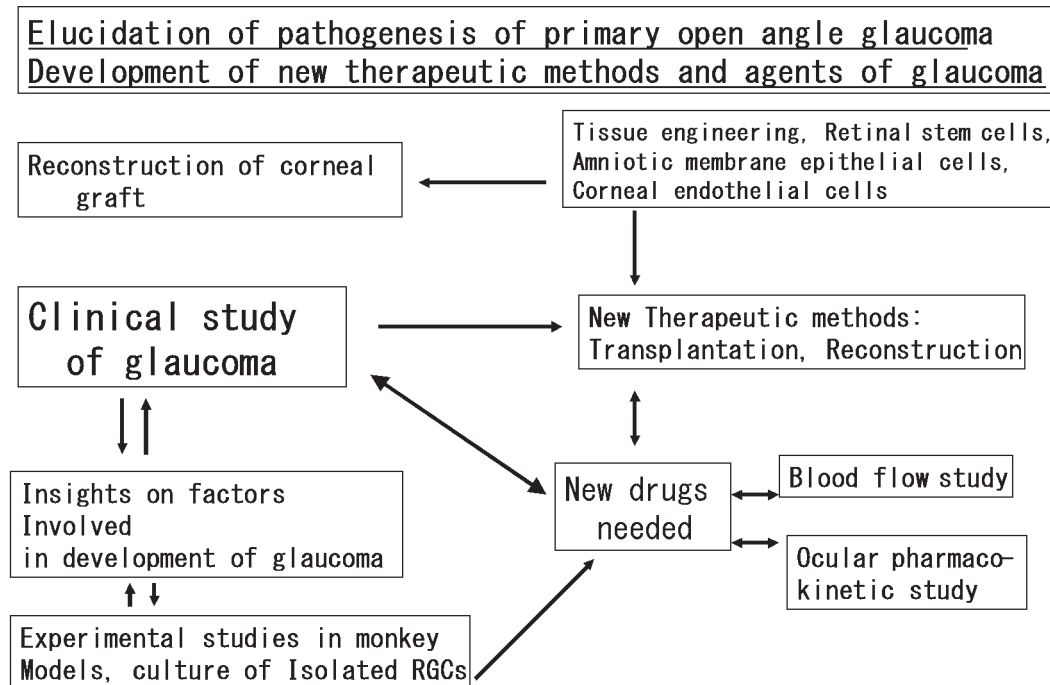

already developed for non-invasive measurement of peripheral blood flow in ocular tissues, an apparatus for Color Doppler Imaging and that for Laser Doppler Velocimetry have been recently introduced. The former measures the absolute blood velocity of vessels in the orbit (diameter > 100 μ) and the latter that of large retinal vessels (diameter \approx 100 μ). Our laboratory is the only one in the world that equipped with the above 3 apparatuses and using 3 apparatuses, physiology, pathology and pharmacology of ocular circulation from feeding vessels to peripheral circulation can be first systematically investigated. The subjects of the on-going studies are: Measurement of peripheral resistance in normal subjects with genetically high risk for systemic hypertension; Change in autoregulatory capacity of retinal and ONH circulation with aging, development of glaucoma or development of diabetic retinopathy; and Assessment of hemodynamic parameters most correctly and sensitively reflecting status of peripheral vascular bed. The results obtained by above studies will shed light not only on further understanding of pathophysiology of systemic hypertension and ocular disorders associated with circulatory abnormalities, but also lead to establishment of hemodynamic parameters most sensitively reflecting therapeutic effects of various drugs on retinal or ONH disorders including glaucoma.

Research Grants

Grant-in-aid for scientific research from Ministry of Education, Culture, Sports, Science and Technology:

1. Tenkai-Kenkyu (A)2, No.10357016, 1998-1999: Chief investigator, ¥19,500,000

2. Kiban-Kenkyu (A)1, No. 11307036, 1999-2001: Chief investigator, ¥41,010,000
3. Kiban-Kenkyu (B)2, No. 12557146, 2000-2001: Chief investigator, ¥19,700,000
4. Kiban-Kenkyu (A)1, No. 14207069, 2002-2004: Chief investigator, ¥49,998,000

Grant-in-aid for scientific research from Ministry of Health, Labour and Welfare

- H-10-Sensory Organ-005, 1998-2000: Chief investigator, ¥73,500,000

Select Publications

1. Makoto ARAIE, Masahiro TAKASE, Yasuo SAKAI, Yukihisa ISHII, Yukio YOKOYAMA & Masatoshi KITAGAWA: Beta-adrenergic blockers: ocular penetration and binding to the uveal pigment. *Japanese Journal of Ophthalmology* 26:248-263, 1982
2. Makoto ARAIE: A Reevaluation of corneal endothelial permeability to fluorescein. *Experimental Eye Research* 41: 383-390, 1985
3. Makoto ARAIE: Barrier function of the corneal endothelium and intraocular irrigating solutions. *Archives of Ophthalmology*, 104:435-438, 1986
4. Makoto ARAIE & David M MAURICE: The rate of diffusion of fluorophores through the corneal epithelium and stroma. *Experimental Eye Research* 44: 73-87, 1987
5. Chihiro SETO, Makoto ARAIE, Mitsuru SAWA, & Masahiro TAKASE: Human corneal endothelial permeability to fluorescein and fluorescein glucuronide. *Investigative Ophthalmology & Visual Science* 28: 1457-1463, 1987
6. Makoto ARAIE, Eiichi SHIRASAWA & Koji HIKITA: Effects of oxidized glutathione on the barrier function of the corneal endothelium. *Investigative*

- Ophthalmology & Visual Science 29: 1884-1887, 1988
7. Masami KONDO & Makoto ARAIE: Concentration change of 5-fluorouracil in the external segment of the eye after subconjunctival injection. Archives of Ophthalmology, 106: 1718-1721, 1988
 8. Masami KONDO & Makoto ARAIE: Iontophoresis of 5-fluorouracil into the conjunctiva and sclera. Investigative Ophthalmology & Visual Science 30: 583-585, 1989
 9. Tetsuro OSHIKA & Makoto ARAIE: Time course of changes in aqueous protein concentration and flow rate after oral acetazolamide. Investigative Ophthalmology & Visual Science 31: 527-534, 1990
 10. Makoto ARAIE, Eiichi SHIRASAWA & Tokie OHHASHI: Intraocular irrigating solutions and permeability of the blood-aqueous barrier. Archives of Ophthalmology, 108: 882-885, 1990
 11. Makoto ARAIE, Koichi HAMANO, Shuichiro EGUCHI & Shun MATSUMOTO: Effect of calcium ion concentration of the permeability of the corneal endothelium. Investigative Ophthalmology & Visual Science 31:2191-2193, 1990
 12. Makoto ARAIE & David M Maurice: The loss of fluorescein, fluorescein glucuronide and FITC-dextran from the vitreous by the anterior and retinal pathways. Experimental Eye Research 52: 27-39, 1991
 13. Mikiro MORI & Makoto ARAIE: A simple method of determining the time course of timolol's effects on aqueous flow in humans. Archives of Ophthalmology 109: 1099-1103, 1991
 14. Tetsuro OSHIKA, Makoto ARAIE, Tetsuya SUGIYAMA, Masayuki NAKAJIMA & Ikuo AZUMA: Effect of bunazosin hydrochloride on intraocular pressure and aqueous humor dynamics in normotensive human eyes. Archives of Ophthalmology 109: 1569-1574, 1991
 15. Mikiro MORI, Makoto ARAIE, Masahiro SKURAI & Tetsuro OSHIKA: Effects of pilocarpine and tropicamide on blood-aqueous barrier permeability in man. Investigative Ophthalmology & Visual Science 33: 416-423, 1992
 16. Yasuyuki SUZUKI, Makoto ARAIE & Yazuo OHASHI: Sectorization of central 30° visual field in glaucoma. Ophthalmology 100: 69-75, 1993
 17. Satoshi KOYANO, Makoto ARAIE & Shuichiro EGUCHI: Movement of fluorescein and its glucuronide across retinal pigment epithelium-choroid. Investigative Ophthalmology & Visual Science 34: 531-583, 1993
 18. Junkichi YAMAGAMI, Makoto ARAIE, Makoto AIHARA & Seiichiro YAMAMOTO: Diurnal variation in intraocular pressure of normal-tension glaucoma eyes. Ophthalmology 100: 643-650, 1993
 19. Makoto ARAIE, Junkichi YAMAGAMI & Yasuyuki SUZUKI: Visual field defects in normal-and high-tension glaucomas. Ophthalmology 100: 1808-1814, 1993
 20. Makoto ARAIE & Kiyoshi ISHII: Effects of apraclonidine on intraocular pressure and blood-aqueous barrier permeability after phacoemulsification and intraocular lens implantation. American Journal of Ophthalmology 116: 67-71, 1993
 21. Makoto ARAIE, Maki SEKINE, Yasuyuki SUZUKI & Nobuyuki KOSEKI: Factors contributing to the progression of visual field damage in eyes with normal-tension glaucoma. Ophthalmology 101: 1440-1444, 1994
 22. Yasuhiro TAMAKI, Makoto ARAIE, Eizo KAWAMOTO, Shuichiro EGUCHI & Hitoshi FUJII: Noncontact, two-dimensional measurement of retinal microcirculation using laser speckle phenomenon. Investigative Ophthalmology & Visual Science 35: 3825-3834, 1994
 23. Yasuhiro TAMAKI, Makoto ARAIE, Eizo KAWAMOTO, Shuichiro EGUCHI & Hitoshi FUJITA: Non-contact, two-dimensional measurement of tissue circulation in choroid and optic nerve head using laser speckle phenomenon. Experimental Eye Research 60: 373-384, 1995
 24. Minoru KIMURA, Makoto ARAIE & Satoru KOYANO: Movement of carboxyfluorescein across retinal pigment epithelium-choroid. Experimental Eye Research 63: 51-56, 1996
 25. Hiromu K MISHIMA, Kanjiro MASUDA, Yoshiaki KITAZAWA, Ikuo AZUMA & Makoto ARAIE: A comparison of latanoprost and timolol in primary open-angle glaucoma and ocular hypertension. A 12-week study. Archives of Ophthalmology 114: 929-932, 1996
 26. Nobuyuki KOSEKI, Makoto ARAIE, Shiroaki SHIRATO & Seiichiro YAMAMOTO: Effect of trabeculectomy on visual field performance in central 30° visual field in progressive normal tension glaucoma. Ophthalmology 104: 197-201;1997
 27. Makoto ARAIE, Mariko KITAZAWA & Nobuyuki KOSEKI : Intraocular pressure and central visual field of normal tension glaucoma. British Journal of Ophthalmology 81:852-856,1997
 28. Makoto ARAIE & Minoru KIMURA: Intraocular irrigating solutions and barrier function of retinal pigment epithelium. British Journal of Ophthalmology 81: 150-153;1997
 29. Mikiko KANNO, Makoto ARAIE, Ken TOMITA & Kimio SAWANOBORI. Effects of topical nipradilol, a β - blocking agent with α -blocking and nitroglycerin-like activities, on aqueous humor dynamics and fundus circulation. Investigative Ophthalmology & Visual Science 39:736-743,1998
 30. Atsuo TOMIDOKORO, Makoto ARAIE, Yasuhiro TAMAKI & Ken TOMITA. In vivo measurement of iridial circulation using laser speckle phenomenon. Investigative Ophthalmology & Visual Science 39:364-371,1998
 31. Nobuyuki KOSEKI, Makoto ARAIE, Junkichi YAMAGAMI, Shiroaki SHIRATO & Seiichiro YAMAMOTO. Effect of oral brovincamine on visual field damage in normal tension glaucoma with low-normal pressure. Journal of Glaucoma 8:117-123,1999

32. Ken TOMITA, Makoto ARAIE, Yasuhiro TAMAKI, Miyuki NAGAHARA & Tetuya SUGIYAMA. Effects of nilvadipine, a calcium antagonist, on rabbit ocular circulation and optic nerve head circulation in normal tension glaucoma subjects. *Investigative Ophthalmology & Visual Science*. 40: 1144-1151, 1999
33. Yasuhiro TAMAKI, Makoto ARAIE, Miyuki NAGAHARA & Ken TOMITA. Acute effects of cigarette smoking on tissue circulation in human optic nerve head and choroid-retina. *Ophthalmology* 106:564-569, 1999
34. Mikiko KANNO, Makoto ARAIE, Hiroshi KOIBUCHI & Kanjiro MASUDA. Effects of topical nipradilol, a β -blocking agent with α -blocking and nitroglycerin-like activities, on intraocular pressure and aqueous dynamics in humans. *British Journal of Ophthalmology* 84:293-299, 2000
35. Yuichi KAJI, Tomohiko USUI, Tetsuro OSHIKA, Masao MATUBARA, Hidetoshi YAMASHITA, Makoto ARAIE, Toshinori MURATA, Tetsuro ISHIBASHI, Ryoji NAGAI, Seikoh HORIUCHI & Shiro AMANO. Advanced Glycation end products in diabetic corneas. *Investigative Ophthalmology & Visual Science* 41:362-368, 2000
36. Fumiko TANIGUCHI, Yasuyuki SUZUKI, Hiroki KURIHARA, Yukiko KURIHARA, Hiroyoshi KASAI, Shiroaki SHIRATO & Makoto ARAIE. Molecular cloning of the bovine MYOC and induction of its expression in trabecular meshwork cells. *Investigative Ophthalmology & Visual Science* 41:2070-2075, 2000
37. Kenji INOUE, Shunichiro KUBOTA, Tadahiko TSURU, Makoto ARAIE & Yousuke SEYAMA. Cholesterol induces apoptosis of corneal endothelial and lens epithelial cells. *Investigative Ophthalmology & Visual Science* 41:991-997, 2000
38. Tomohiko USUI, Shiro AMINO, Kaori SUZUKI, Kazunori MIYATA, Makoto ARAIE, Paraskevi HELDIN & Hidetoshi YAMASHITA. Expression and regulation of hyaluronan synthase in corneal endothelial cells. *Investigative Ophthalmology & Visual Science* 41:3261-3267, 2000
39. Saiko UCHIDA, Yukiko INANAGA, Makiko KOBAYASHI, Shoei HURUKAWA, Makoto ARAIE & Norio SAKURAGAWA. Neurotrophic function of conditioned medium from human amniotic epithelial cells. *J Neuroscience Research* 62:585-590, 2000
40. Yasuhiro TAMAKI, Makoto ARAIE, Tomohiko HASEGAWA & Miyuki NAGAHARA. Optic nerve head circulation after intraocular pressure reduction achieved by trabeculectomy. *Ophthalmology* 108: 627-632, 2001
41. Ken MIZUNO, Takashi KOIDE, Mitsuo YOSHIMURA & Makoto ARAIE. Neuroprotective effect and intraocular penetration of nipradilol, a beta-blocker with nitric oxide donative action. *Investigative Ophthalmology & Visual Science* 42:688-694, 2001
42. Tomohiko USUI, Masumi HARA, Hiroaki SATOH, Nobuo MORIYAMA, Humie KAGAYA, Shiro AMANO, Tetsuro OSHIKA, Yasuo ISHII, Nobuhiro IBARAKI, Chiaki HARA, Motoei KUNIMI, Eisei Noiri, Kazuhisa TSUKAMOTO, Jun INATOMI, Hayato KAWAKAMI, Hitoshi ENDOU, Takashi IGARASHI, Astuo GOTO, Toshiro FUJITA, Makoto ARAIE, George SEKI. Molecular basis of ocular abnormalities associated with proximal renal tubular acidosis. *Journal of Clinical Investigation* 2001;108:107-115
43. Yukihiko MASHIMA, Yasuyuki SUZUKI, Yuri SERGEEV, Yuichiro OHTAKE, Tomihiko TANINO, Itaru KIMURA, Hiroshi MIYATA, Makoto AIHARA, Hidenobu TANIHARA, Masaru INATANI, Noriyuki AZUMA, Takeshi IWATA, Makoto ARAIE. Novel cytochrome P4501B1(CYP1B1) gene mutations in Japanese patients with primary congenital glaucoma. *Investigative Ophthalmology & Visual Science* 2001;42: 2211-2216
44. Kenji KASHIWAGI, Yoko IIZUKA, Makoto ARAIE, Yasuyuki SUZUKI, Shigeo TSUKAHARA. Effects of retinal glial cells on isolated rat retinal ganglion cells. *Investigative Ophthalmology & Visual Science* 2001;42:2686-2694
45. Saiko UCHIDA, Yasuyuki SUZUKI, Makoto ARAIE, Takashi SHIGEEDA, Takeshi HARA, Shiroaki SHIRATO. Long-term follow-up of initial 5-fluorouracil trabeculectomy in primary open-angle glaucoma in Japanese patients. *Journal of Glaucoma* 2001;10:458-465
46. Kiyoshi ISHII, Atsuo TOMIDOKORO, Miyuki NAGAHARA, Yasuhiro TAMAKI, Mikiko KANNO, Yasuhiro FUKAYA, Makoto ARAIE. The effects of topical latanoprost on optic nerve circulation in rabbits, monkeys and humans. *Investigative Ophthalmology & Visual Science* 2001;42:2957-2963
47. Takashi SHIGEEDA, Atsuo TOMIDOKORO, Makoto ARAIE, Nobuyuki KOSEKI, Seiichiro YAMAMOTO. Long-term follow-up of visual field progression after trabeculectomy in progressive normal-tension glaucoma. *Ophthalmology* 2002;109:766-770
48. Miyuki NAGAHARA, Atsuo TOMIDOKORO, Sawako SANDO, Makoto ARAIE, Sumiyoshi TANAKA. MD., Ph.D. MD., Ph.D. An apparatus for color Doppler imaging in seated subjects. *American Journal of Ophthalmology* 2002;133:270-272
49. Hiroshi MATSUO, Atsuo TOMIDOKORO, Yasuyuki SUZUKI, Shiroaki SHIRATO, Makoto ARAIE. Late-onset transconjunctival oozing and point leak of aqueous humor from filtering bleb after trabeculectomy. *American Journal of Ophthalmology* 2002; 133: 456-462
50. Chihiro MAYAMA, Yasuyuki SUZUKI, Makoto ARAIE, Kyoko ISHIDA, Akira TSUJI, Tetsuya YAMAMOTO, Yoshiaki KITAZAWA, Shigeo FUNAKI, Motohiro SHIRAKASHI, Haruki ABE, Hidetoshi TSUKAMOTO, Koji OKADA, Hiromu K MISHIMA. Myopia and advanced-stage open angle glaucoma. *Ophthalmology* (in press)

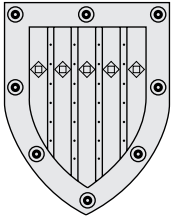

Department of Otorhinolaryngology, Head and Neck surgery

Outlines

The Department of Otorhinolaryngology was founded in 1899 by Prof. Waichiro Okada. This is the first department of otorhinolaryngology of the medical school and the university hospital in Japan. The first professor, Waichiro Okada (1902-1924), the 2nd, Taneji Masuda (1924-1946), the 3rd, Kotoji Satta, the 4th, Ichiro Kirikae (1947-1969), the 5th, Yasuo Sato (1970-1980), the 6th, Yasuya Nomura (1980-1991), the 7th, Kimitaka Kaga (1992-)

Research Objectives

Our department covers all of otorhinolaryngological diseases and associated systemic diseases, and has specialized clinical and basic research in middle ear and inner ear diseases, peripheral and central deafness in infant and children, adult and elderly, facial paresis, vertigo and balance disorders, olfactory disorders, paranasal diseases, voice and speech disorders, cleft palate, taste and swallowing disorders, head & neck cancer, psychosomatic medicine and medical education.

- 1) Hearing research; Morphology and neurophysiology of the inner ear focusing on sensory neural deafness: human temporal bone pathology, electron microscopic study in animal models with gene abnormality, clinical application of otoacoustic emissions and auditory brainstem responses. Hair cell physiology of synaptic transmission.
- 2) Facial nerve research; Morphology of the facial nerves focusing on degeneration and regeneration.
- 3) Head and neck cancer research; Molecular biology and gene therapy of head and neck cancers.
- 4) Evoked potential research; Generators of auditory evoked potentials in the central auditory system.
- 5) Auditory perception and cognition research; normal subjects and patients with central deafness and cochlear implant using event related potentials and MEG.
- 6) Voice research; Morphology and electrophysiology of the larynx and voice production.
- 7) Basic research on auditory brainstem implant.
- 8) Vestibular research; The oculomotor and balance system in the brainstem, cerebellum and cerebrum. Vestibular myogenic evoked potential and its origin and clinical application.
- 9) Taste research; Taste perception and disorders.
- 10) Olfactory research; Olfactory epithelium morphology and function of olfaction.
- 11) Language research; Development of hearing, speech and language in neonates and infants.
- 12) Artificial organ research; Development of artificial sensory and motor organs.

Faculties and Students

Professor	Kimitaka Kaga, MD,PhD (1992-)	Associate	10
Associate Professor	Masashi Sugawara, MD, Tatsuya Yamasoba, MD	Postdoctoral Fellow	2
Lecturer	Toshihisa Murofushi, MD,PhD, Naonobu Takeuchi, MD,PhD Ken Ito, MD,PhD, Kenichiro Ishio, MD Ryuzaburo Higo, MD,PhD	Graduate Student	6
		Research Student	4
		Secretary	3

Past Research and Major Accomplishments

Otology and neurotology

1. Development of new surgical procedure: total middle ear reconstruction and auricle, canal plasty and ossicular reconstruction for congenital microtia and atresia.
2. Comprehensive study on central auditory system and central auditory disorders.
3. Demonstration of origins of auditory evoked potentials in animal and human subjects: auditory brainstem response and middle latency.
4. Introduction of gene therapy into inner ear diseases.
5. Demonstration of sound lateralization of bone conduction hearing.
6. Invention of bilateral bone conduction hearing aid.
7. Discovery of a new hearing disorder of auditory nerve disease.
8. Proposal of new critical age of language development.
9. Mechanism of perception and cognition of music and environmental sounds.
10. Discovery of a new antibody of inner ear.

Head and Neck Cancer:

1. Long term follow up study on different treatment of maxillary cancer and proposal of the best treatment.
2. Identification of adeno virus in nasopharyngeal cancer.
3. Development of new chemotherapy of head and neck cancer.
4. Development of new surgical procedure for parathyroid tumor.

Rhinology:

Demonstration of developing and aging changes of olfactory neuroepithelium.

Laryngology:

Development of new artificial voice production system for patients after total laryngectomy.

Bronchoesophagology

Development of electrophysiological swallowing system.

Medical education:

1. Introduction of clinical counselling with head and neck cancer patients for medical students in bedside learning.
2. Evaluation system of teachers in medical school by medical students.

Current Research

Otology and neurotology

I. Clinical research

1. Early operation of cochlear implant around two years of age.
2. Music perception of children and adults with cochlear implant.
3. Sound lateralization perception and time-intensity trading ability in normal subjects with absolute pitch and patients with brain damage.
4. Development of super-low noise bone conduction hearing aid.
5. Cooperative reconstruction surgery of auricle and canal plasty for congenital microtia and atresia by plastic surgeons and otological surgeons.
6. New total middle ear reconstruction surgery for infectious radicalized ears.
7. Implantation of bone anchored hearing aid for children with Treacher Collins syndrome.
8. Early discovery of congenital deafness in neonates and early hearing aid fitting and education of speech and language.
9. Contribution to double handicapped children with hearing problem.
10. Perception and cognition of cortical deafness.

II. Basic study

1. Development of polyimide multiple-site surface microelectrode for epidural cortical recording of high spatial resolution evoked-potentials.
2. Development of independent component analysis of multiple-site auditory evoked potentials.
3. Molecular biology of inner ear hair cell differentiation.
4. Molecular biology of experimental noise induced deafness.
5. Regeneration mechanism of inner ear hair cells in chick.
6. Development of gene therapy for experimental inner ear diseases.
7. Origin of binaural interaction of hearing using midline section of brainstem and localized lesions of brainstem in animal models.
8. Plasticity of central auditory system.

Head and neck surgery

1. Development of a new procedure of skull base surgery.
2. Molecular biological study on hypopharyngeal cancer.
3. Development of a new procedure of partial laryngectomy.

4. Quality of life between conservative and surgical treatment.
5. Development of navigation to support safer head and neck surgery.

Rhinology

1. Olfaction change of human subjects under environment of modern society.
2. A study on distribution of histamine receptor in human nasal mucosa.
3. Application of navigation system for endoscopic nasal surgery.

Laryngology, Bronchoesophagology

1. Application of Botulinus toxin to treat spastic dysphonia.
2. A new procedure to treat hoarseness in elderly patients implanting fascia in the vocal cord.
3. Language development of children using tracheal canula in the first year of life.
4. Comparative study of vocal cords in differential species.
5. Measurements of pressure changes of swallowing system in patients with dysphagia.
6. Surgical procedures to treat dysphagia.

Medical education

1. How to teach humanity in medical education.
2. Development of assessment of teachers activity in lectures, seminars and bedside learning in medical education.

Future Prospects

New artificial sensory and motor organs and gene therapy will be new directions checked by gene analysis of each cancer individually and treated by

1. Otolaryngology: After present cochlear implant for profound sensory deafness, we will challenge to create a new cochlear implant for music perception, auditory brainstem implant for neural deafness and super low noise bilateral bone conduction hearing aids for conductive deafness.
2. Head and neck surgery: Head and neck cancer treatment will be checked by gene analysis of each cancer individually and treated by gene therapy due to philosophy based on tailored medicine.
3. Rhinology: Allergic rhinitis is incurable diseases but will be challenged by new immunotherapy. Sensory and neural anosmia is desperate to recover at present but will be challenged to innovate artificial sensory device for implantation in olfactory bulb.
4. Laryngology: Voice is very important in communication. Loss of vocal cord result from total laryngectomy because of surgical cancer treatment.

Now we are challenging to innovate new computerized devices for providing the same voice from the oral cavity before surgery which uses voice synthesis technology and orally fitted voice generating system.

Research Grants

- 1998 Hatamura Y, Ishii T, Kaga K: Advanced medical tools for clinicians and development of fine instruments. Ministry of Welfare. 1998-2001, Total ¥400,000,000.
- 1999 Kaga K, et al: Basic study on auditory brainstem implant. Ministry of Education. 1999-2001, Total ¥14,000,000.
- 2000 Kaga K, et al: Study on auditory space in higher brain. Ministry of Education. 2000-2001, Total ¥6,000,000.
- 2001 Kaga K: Identification of sound localization in human brain. Ministry of Education ¥2,100,000.
- 2002 Kaga K, et al: Neonatal universal screening and long term follow up. Ministry of Welfare and Labor ¥1,260,000.

Select Publications

1. Kaga K, Uebo K, Sakata H, Abe Y, Haebara H, Kosakai M: Auditory brainstem responses and temporal bone and brainstem pathology in brainstem death, with special reference to autolysis of red blood cells. *Acta Otolaryngol (Stockh)* 115:183-186,1995.
2. Kaga K, Tanaka Y: Auditory air and bone conduction brainstem responses and damped rotation test for young children with bilateral congenital atresia of the ears. *Int J Pediat Otorhinolaryngol* 32:13-21,1995.
3. Kaga K, Tamai F, Kitazumi E, Kodama K: Auditory brainstem responses in children with Cornelia de Lange syndrome. *Int J Pediat Otorhinolaryngol* 31:137-146,1995.
4. Kaga K, Nakamura M, Shinogami M, Tsuzuku T, Yamada K, Shindo M: Auditory nerve disease of both ears revealed by auditory brainstem responses, electrocochleography and otoacoustic emissions. *Scandinavian Audiol* 25:233-238,1996.
5. Ismail Noorhassim, Kaga K: Pure tones audiometry and auditory brainstem responses in noise-induced deafness. *American J Otolaryngol* 17:31-35,1996.
6. Suzuki M, Kaga K: Effect of cisplatin on the negative charge barrier in strial vessels of the guinea pig. A transmission electron microscopic study using polyethyleneimine molecules. *Eur Arch Otorhinolaryngol* 253:351-355,1996.
7. Yamada K, Kaga K, Uno A, Shindo M: Sound lateralization in patients with lesions including the auditory cortex: comparison of interaural time difference (ITD) discrimination and interaural intensity difference (IID) discrimination. *Hearing Research* 101:173-180,1996.

8. Yamasoba T, Oka Y, Tsukuda K, Nakamura M, Kaga K: Auditory findings in patients with maternally inherited diabetes and deafness harboring a point mutation in the mitochondrial transfer RNA^{Leu}(UUR) gene. *Laryngoscope* 106:49-53,1996.
9. Yamasoba T, Suzuki M, Kaga K: Influence of chronic kanamycin administration on basement membrane anionic sites in the labyrinth. *Hearing Research* 102:116-124,1996.
10. Kaga K, Shindo M, Tanaka Y: Central auditory information processing in patients with bilateral auditory cortex lesions. *Acta Otolaryngol (Stockh) Suppl* 532:77,82,1997.
11. Tanioka H, Kaga K, Zusho H, Araki T, Sasaki Y: MR of the endolymphatic duct and sac: findings in Meniere disease. *AJNR Am J Neuroradiol* 18:45-51,1997.
12. Suzuki M, Kaga K: Effect of cisplatin on the basement membrane anionic sites in the ampulla, macula, and strial vascularis of guinea pigs. *Ann Otol Rhinol Laryngol* 106:971-975,1997.
13. Nakamura M, Yamasoba T, Kaga K: Changes in otoacoustic emissions in patients with idiopathic sudden deafness. *Audiology* 36:121-135,1997.
14. Yamada K, Kaga K, Sakata H, Uno A, Tsuzuku T: Auditory evoked potentials under total spinal anesthesia in rats. *Ann Otorhinolaryngol* 108:1092,1997.
15. Suzuki Y, Kaga K, Sugiuchi Y, Ishii T, Suzuki J-I, Takiguchi T: Sudden bilateral hearing loss due to gastric carcinoma and its histological evidence. *J Laryngol Otol* 111:1142-1146,1997.
16. Kojima Y, Kaga K, Shindo M, Hirose A: Electromyographic examination of patients with unilateral cortical facial paralysis. *Otolaryng Head Neck Surg* 117:S121-124,1997.
17. Kaga K, Uebo K, Sakata H, Suzuki J: Auditory and vestibular pathology in brainstem death revealed by auditory brainstem response. *Acta Otolaryng (Stockh) Suppl* 503:95-103,1993
18. Uno A, Kaga K, Tsuzuku T, Kuroki M: Middle-latency responses of awake and anesthetized Japanese macaques. *Audiology* 32:302-307,1993.
19. Kim LS, Kaga K, Tsuzuku T, Uno A: Effects of primary auditory cortex lesions on middle latency responses in awake cats. *A.N.L. (Tokyo)* 20:155-165,1993.
20. Yamada K, Kaga K, Tsuzuku T, Uno A: Analysis of auditory brain stem response with lidocaine injection into the cerebrospinal fluid in rats. *Ann Otol Rhinol Laryng* 103:796-800,1994.
21. Yamada K, Kaga K, Suzuki J-I: Temporal bone pathology in patients without caloric response. *Acta Otolaryngol (Stockh)* 114:586-594,1994.
22. Iwasaki S, Kaga K: Chronological changes of auditory brainstem responses in Cockayne's syndrome. *Int J Pediatr Otolaryng* 30:211-221,1994.
23. Kaga K, Uebo K, Sakata H, Abe Y, Haebara H, Kosakai M: Auditory brainstem responses and temporal bone and brainstem pathology in brainstem death, with special reference to autolysis of red blood cells. *Acta Otolaryngol (Stockh)* 115:183-186,1995.
24. Kaga K, Ichimura K, Kitazumi E, Kodama K, Tamai F: Auditory brainstem responses in infants and children with anoxic brain damage due to near-suffocation or near-drowning. *Int J Pediatr Otorhinolaryngol* 36:231-239,1996.
25. Kaga K, Nakamura M, Shinogami M, Tsuzuku T, Yamada K, Shindo M: Auditory nerve disease of both ears revealed by auditory brainstem responses, electrocochleography and otoacoustic emissions. *Scandinavian Audiol* 25:233-238,1996.
26. Iwasaki S, Kaga K, Yagi M, Kuroda M: Vestibular findings syndrome. *ORL* 58:343-346,1996.
27. Kaga K, Shinoda Y, Suzuki J-I: Origin of auditory brainstem responses in cats: Whole brainstem mapping, and a lesion and HRP study of the inferior colliculus. *Acta Otolaryngol (Stockh)* 117:197-201,1997.
28. Kaga K, Ichimura K: A preliminary report clinical effects of otic solution of ofloxacin in infantile myringitis and chronic otitis media. *Int J Pediatric Otorhinolaryngol* 42:199-205,1998.
29. Suzuki M, Yamasoba T, Kaga K: Development of the blood-labyrinth barrier in the rat. *Hearing Research* 116:107-112, 19989.
30. Suzuki M, Yamasoba T, Kaga K: Effects of chronic administration of Kanamycin on the basement membrane anionic sites in the crista ampullaris of guinea pigs. *Laryngoscope* 108:81-86,1998j.
31. Sakamoto M, Sugawara M, Kaga K, Kamio T: Average thresholds in the 8 to 20 kHz range as a function of age. *Scand Audiol* 27:189-192,1998.
32. Kaga K, Ono M, Yakumaru K, Owada M, Mizutani T: Brainstem pathology of infantile Gaucher's disease with only wave I and II of auditory brainstem response. *J Laryngol Otol* 112:1069-1073,1998.
33. Kaga K, Takeuchi N, Sakurai H: Facial nerve pathology of two patients with herpes simplex encephalitis. A temporal bone study. *Facial Nerve*, pp 1-6, Proc VIII International Symposium on the Facial Nerve. Kugler Pub, The Netherlands, 1998.
34. Kaga K, Yamada K, Tsuzuku T, Uno A: The long-term effect of bilateral inferior colliculus ablation on auditory brainstem response in awake cats. *Acta Otolaryngol (Stockh)* 119:128-131m1999.
35. Kaga K: Vestibular compensation in infants and children with congenital and acquired vestibular loss in both ears. *Int J Pediatr Otorhinolaryngol* 49:215-224,1999.
36. Naito R, Murofushi T, Mizutani M, Kaga K: Auditory brainstem responses, electrocochleograms, and cochlear microphonics in the myelin deficient mutant hamster 'bt'. *Hearing Research* 136:44-48,1999.
37. Yamasoba T, Tsukuda K, Oka Y, Kobayashi T, Kaga K: Cochlear histopathology associated with mitochondrial transfer RNA^{Leu}(UUR) gene mutation. *Neurology* 52:1705-1707,1999.

38. Kaga K, Shindo M, Tanaka Y, Haebara H: Neuropathology of auditory agnosia following bilateral temporal lobe lesions: A case study. *Acta Otolaryngol* 120:259-262,2000.
39. Takegoshi H, Kaga K, Kikuchi S, Ito K: Mandibulofacial dysostosis: CT evaluation of the temporal bones for surgical risk assessment in patients of bilateral aural atresia. *Int J Pediatric Otorhinolaryngol* 54:33-40,2000.
40. Yamada K, Kaga K, Tsuzuku T, Uno A: Long-term changes in middle latency response and evidence of retrograde degeneration in the medial geniculate body after auditory cortical ablation in cats. *Acta Otolaryngol* 120:744-949,2000.
41. Itoh K, Yumoto M, Uno A, Kurauchi T, Kaga K: Temporal stream of cortical representation for auditory spatial localization in human hemispheres. *Neuroscience Letters* 292:215-219,2000.
42. Kaga K, Setou M, Nakamura M: Bone-conducted sound lateralization of interaural time difference and interaural intensity difference in children and a young adult with lateral microtia and atresia of the ears. *Acta Otolaryngol* 121:274-277,2001.
43. Setou M, Kurauchi T, Tsuzuki T, Kaga K: Binaural interaction of bone-conducted auditory brainstem responses. *Acta Otolaryngol* 121:486-489,2001.
44. Sheykholeslami K, Kaga K, Tsuzuku T, Mizutani M: Electrophysiological measures of auditory function in the neurofilament-deficient mutant quail (Quv). *Hearing Research* 153:115-122,2001.
45. Kaga K, Sakurai H, Ogawa Y, Mizutani T, Toriyama M: Morphological changes of vestibular ganglion cells in human fetuses and in pediatric patients. *Int J Pediatric Otorhinolaryngol* 60:11-20,2001.
46. Komura Y, Tamura R, Uwano T, Nishijo N, Kaga K, Ono T: Retrospective and prospective coding for predicted reward in the sensory thalamus. *Nature* 142:546-549,2001.
47. Sheykholeslami K, Kermany MH, Kaga K: Frequency sensitivity range of the saccule to bone-conducted stimuli measured by vestibular evoked myogenic potentials. *Hearing Research* 160:58-62,2001.
48. Kaga K, Yasui T, Yuge T: Auditory behaviors and auditory brainstem responses of infants with hypogenesis of cerebral hemispheres. *Acta Otolaryngol* 122:16-20,2002.
49. Kondo K, Sagara H, Hirosawa K, Kaga K, Matsushima S, Mabuchi K, Uchimura H, Watanabe T: Hair cell development in vivo and in vitro: analysis by using a monoclonal antibody specific to hair cell in the chick inner ear. *J Comp Neurol* 445:176-198,2002.
50. Ishimoto S, Ho K, Sasaki T, Shinogami M, Kaga K: Total middle ear reconstructive surgery for the radicalized ear. *Otol Neurotol* 23:262-266,2002.

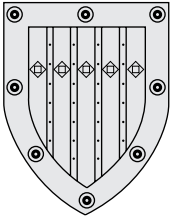

Department of Rehabilitation Medicine

Outline and Research Objectives

The Department of Rehabilitation Medicine was established by Ministry of Education, Culture, Sports, Science and Technology in April 2001. It is one of the newest fields in the University of Tokyo Graduate School of Medicine. It belongs to the Sensory and Motor System Medicine Course of the Surgical Sciences Study Major. Current staff is only one professor. We have accepted the graduate school student formally since fiscal year 2001 when the Rehabilitation Medicine Field was installed in. Two students of the first year class of graduate school and two of the second year class started some rehabilitation research. An activity of our department is at one with the Central Rehabilitation Service of the university hospital. As for the staff of the rehabilitation service of the university hospital, there are one lecturer, one associate and three part-time medical doctors. In addition, one temporary associate has accompanied in April 2002, and he takes charge of the day hospital in psychiatry rehabilitation.

The Central Rehabilitation Service derives from the establishment of the exercise therapy room in 1963 in the central medical service department. It aimed at the development of the medical rehabilitation in our country corresponding to needs of rehabilitation service that had become clear in the health care of the 20th century middle.

In the university hospital, the rehabilitation section increased and maintained a hydrotherapy room and the occupational therapy room, etc., and it was renamed the rehabilitation center in 1966. Then, it became an independent section by changing the title as the central rehabilitation service in 1970. Both were names by measures in the hospital. A formal name of the section was a department of physical therapy. The professor employment was set up as a full-time medical director in 1984. However, a formal name of the section was still a physical therapy department.

Rehabilitation medicine is a comprehensive medical management of disability including its diagnosis and treatment. It was born in the flow of the health care and medical service at modern ages by which it came to value the enhancement of not only extending years of patient's life but also adding life to years. In Declaration of Alma-Ata by World Health Organization (WHO) of 1978, it was described, "primary health care addresses the main health problems in the community, providing promotive, preventive, and curative and rehabilitative services". Regardless of rapid expansion of those needs, acknowledgment of medical rehabilitation was delayed in the frame of conventional diagnosis and treatment department. In our country, it was 1996 that the rehabilitation department was authorized as the formal clinical department in the health insurance system by the former Ministry of Health and Welfare. On the other hand, the professor of the physical therapy department was positioned as an assistance instructor in the sensory and motor system medicine course by the University of Tokyo Faculty of Medicine having shifted to the graduate school course system between fiscal year 1995 and fiscal year 1997.

In the university hospital, the name was changed from the physical therapy department to the rehabilitation medicine department by the budget measures in fiscal year 2001. Now we integrated related occupational categories, which had historically belonged to the orthopedic surgery department and the former physical medicine department, and started the maintenance of the department. The Central Rehabilitation Service includes 14 physical therapists (one person is a part-time) and 5 occupational therapists and 5 acupuncture therapists as a rehabilitation team staff other than current medical doctors.

Our mission is to provide exceptional rehabilitation for our patients through clinical excellence and compassionate care, all dedicated to helping patients achieve their maximum functional capacity and highest quality of life. Another significant focal point of the Department is research. The research objectives of the Department are to make clear configuration of disabilities and to develop measures to reduce the obstacles for patients' independent living as well as to promote reintegration in their society.

Faculties and Students

Professor and Chair	Eto, Fumio, MD, Ph. D (1998~)
Lecturer	Kodama, Yoshiaki, MD, Ph. D
Associate2
Visiting Fellow1
Graduate student4
Secretary1 (part-time employment)

Past Research and Major Accomplishments

The rehabilitation medicine field had not been admitted as an established course before reorganization of the graduate school course system. Therefore, there is still no own laboratory space. There is yet no space of doctor's medical office and other staff's duty rooms in the university hospital though the physical therapy department has been engaged in the medical service activity of rehabilitation since 1963. In our conventional research activity, a clinical research that adheres to a daily medical management in rehabilitation has been a major subject.

Research topics that have been executed so far are the following content.

1. The influence of the trouble in patient's daily life due to various diseases is analyzed, and an appropriate treatment program is developed. It is included to describe natural course of the disease and the trouble clearly in life cycle of physically handicapped person. A study to make clear a pattern of the disorder type change in cerebral palsy by the development process from infancy was done. Natural course of Werdnig-Hoffmann disease and congenital muscular dystrophy, which were a rare pediatric disease, was described, and the indication of rehabilitation was clarified.
2. Proper management of the factor disturbing rehabilitation process is important in everyday medical rehabilitation care. The pain management was a typical problem, and the pathophysiological study on shoulder-hand syndrome in poststroke patients was done.
3. Most of activities in daily life depend on walking and locomotion ability. Especially, a study about evaluation method of gait abnormalities and development of specific treatment of an abnormal gait is necessary for regain of useful mobility in physically disabled. The effect of various shoe insoles including arch support as apparatus for treatments was clarified by the gait analysis system.
4. We have studied on development of rehabilitation therapy to promote independent living of the patients with higher brain dysfunction due to cerebrovascular disorders, traumatic brain injury, Alzheimer's disease and so on. Such a study

included the development of assessment tools to evaluate the effectiveness of the rehabilitative intervention.

5. The ordering a bed rest is one of the treatment measures. We have clarified the meaning of disuse syndromes in the rehabilitation as the adverse effect, which includes the deconditioning state. Moreover, decreased activity in daily life after discharge from hospital may be a significant cause of disuse syndromes, especially in the older people. The research on risk factors of accidental fall has revealed that incidence of fall is higher in the older people with decreased daily activities.
6. The disuse syndromes and hypoactive daily life may be serious matter in the poststroke patients living in the community. We have examined the influence of daily activity on changes in the physical fitness of people with poststroke hemiplegia. Then, we have concluded that they can improve their physical fitness without formal supervised training by simply increasing their daily activities.
7. We have developed the comprehensive assessment tool of activities of daily living (ADL) for the elderly based on the hierarchical structure of the ADL. In rehabilitation of the dementia patients the usefulness of ADL measurement has been revealed for classification of the severity of dementia as well as for evaluation of the effect of rehabilitation program.
8. A basic research including animal experiment is also necessary to improve the rehabilitation management. In collaboration with some outside laboratories we have studied a causative mechanism of muscle atrophy, joint contracture and bone atrophy, which are main components of disuse syndromes. In addition, we have examined the effect of physical agents in such a condition; for example, effects of dietary calcium depletion and repletion on tibial bone volume, influences of exercise and mechanical loading on bone strength, effects of electrical stimulation for reducing the degree of joint contracture, and so on.

Current Research

The department's research interests are directed towards reduction of the major disabilities of the handicapped persons, namely immobility, instability and intellectual impairment. The approach is both theoretical, by seeking a better understanding of the baneful processes which produce disability in daily life of the handicapped persons; and practical by the introduction and evaluation of new methods of management. Research workers of variety of medical and non-medical backgrounds shall work together on these problems. Such a research policy is the future

directionality, but the present state is in extension of the past research activities.

Two or more equipment (force platform, video operation analysis system, surface electromyography, and ataxiometer, etc.) are usually combined for the evaluation of walking and motion disturbances. This combined operation analysis system is arranged for the synchronized determination. In addition, synchronous measurements such as the torque machines for the muscular power measurement and the surface electromyography are possible. We have been analyzing human locomotion activities, and also examining the effects of shoes with various insert or heel wedges for walking in normal subjects and physically impaired persons. The present research addresses examining the effects of heel elevation of shoes on walking of the patient with Parkinson's disease. Moreover, a biomechanical change in the walking pattern after surgical operation on the ligaments of the knee has been analyzed with those devices.

The accomplishment of human activities such as locomotion requires the functional integration of at least three major organic systems; the bone, joint, and muscular system that carries out various motions in daily activities; central and peripheral nervous system that controls musculoskeletal system organs; cardiopulmonary system that supplies oxygen and glucose to the former two system organs. Therefore, clinical research interests of rehabilitation medicine are in the development of integrated physical exercise program, the improvement of cardiopulmonary management during rehabilitation therapy, and restorative design for brain damage and nerve injuries. Now we are studying on the evaluation of higher brain dysfunction concerning everyday activities and also on the physical fitness measurement by using the ergometer for the development of an appropriate rehabilitation program.

The clinical practice of rehabilitation is characterized in the team approach by multidisciplinary cooperation. Because two or more specialized professionals work together in practice, the area of research needed is broad. There are a lot of necessary, but unsettled research topics for development and enhancement of rehabilitation practice. However, the physicians and non-medical staffs cannot afford to spend time in the research work because the needs of rehabilitation medical service nowadays increase rapidly in the university hospital. Our present research environment is under a poor condition, and therefore, more cooperation with the outside laboratory or organization including other faculty of the university may be recommended to accomplish the research plan in order to investigate a problem thoroughly.

Future Prospects

Rehabilitation medicine is an important task of primary health care. Theories of disability in health practice and research are area of a new frontier. A research on treatment and prevention of disability depends on the concept and the hypothesis of disability. In addition to an experimental study, a narrative based study in ethnography is important so that the subjective problems like disability experiences may be discussed. Then, not only a biological approach but also a sociological approach should promote it concurrently.

Our academic field has just started. We have requested a laboratory to accomplish experimental study, but it is not given yet. Since historical process and the financial situation of a current university, it is pessimistic to set up the research environment on the university campus. We should struggle with the matter connected directly with the activity of the university hospital, which is a training organization of a medical doctor, though there are an enormous number of unsolved research topics. We have entrusted the attending lecturer to the staff of outside institutions and the organization in order to support our clinical and educational tasks. We are now arranging the cooperation system with staffs of these external institutions for research and development of the welfare equipments to facilitate the independence of the disabled persons. This system may be of help to the research activity coherent to clinical practice in rehabilitation.

The physical therapist and the occupational therapist are new type of jobs in our country in the development process, and they are positioned as medical service staffs in the hospital. It is necessary to increase the chance that those co-medical professionals also participate in the research activity in order to activate a clinical research.

The research of rehabilitation medicine is a new field, internationally. There increases a number of inquiries to hope for studying at our department from several foreign researchers of other Asian nations. Unfortunately, our present environment is insufficient to accept them. Nevertheless, one Chinese doctor and one Mongolia doctor are working with us now. The former has already completed the doctor degree thesis, and the latter is about to start a study now. Professor Eto was invited to Chinese Rehabilitation Medicine Association Conference held in Beijing in China in October 2001 and gave a lecture, entitled "the current situation of rehabilitation medicine in Japan, from a viewpoint of medical education". In addition, he lectured several topics on stroke rehabilitation at the university hospitals in Wuhan city and Shijiazhuang city in China. International cooperation in the rehabilitation medicine research is the future matter.

Table 1. Representative subjects for research grants

Fiscal year	Resource	Subject (Author)	Amount of money (yen)
1998-1999	The MEXT Scientific Research Fund, Basic Research (C)	Study on effect of electric stimulation in prevention of disuse changes of bone and soft tissues (Dr. Akai, M)	1,500,000
2000-2002	The MEXT Scientific Research Fund, Basic Research (C)	Study on effect of heel elevation for Parkinsonian gait (Dr. Eto, F)	4,100,000
2000	The MEXT Scientific Research Fund, Basic Research (C)	Study on functional recovery and ADL of stroke patient's with higher brain dysfunction (Dr. Ohtsuru, I)	1,900,000
2000	The MEXT Scientific Research Fund, Basic Research (C)	Study on evaluation of joint lesion by using noninvasive measures such as vibration response (Dr. Akai M)	3,100,000
2001-2002	Ministry of Health, Labor and Welfare, Research Consignment Expense for Psychiatric and Neurological Disease	Study on functional recovery and ADL in higher brain dysfunction (Dr. Eto, F)	1,600,000

(Abbreviation, MEXT: Ministry of Education, Culture, Sports, Science and Technology)

Research Grants

The total of the competing research expense, which the doctor researcher who belonged to the Central Rehabilitation Service of the university hospital acquired, is 13,200,000 yen since 1998. Five representative research topics and the capital sources are as follows in table 1.

Select Publications

- Ueda S, Miura T, Eto F. Shoulder-Hand Syndrome as an important complication of hemiplegia. *J Jap Ass Phys Med Balneol Climatol* 38: 35-42, 1975.
- Eto F, Yoshikawa M, Morimatsu M, Hirai S, Ueda S. Shoulder-hand syndrome as a complication of hemiplegia. *Jpn J Geriat* 12: 245-251, 1975.
- Eto F, Ueda S. Long-term change of motor patterns in cerebral palsy. *Jpn J Rehabil Med* 14: 261-266, 1977.
- Eto F, Yoshikawa M, Ueda S, Hirai S. Posthemiplegic shoulder-hand syndrome, with special reference to related cerebral localization. *J Am Geriatr Soc* 28: 13-17, 1980.
- Eto F. Complications due to prolonged or excessive rest in rehabilitation medicine. *J Clinical and Experimental Medicine (Igaku no ayumi)* 116: 416-422, 1981.
- Eto F. Activities of daily living of the patients with dementia in the long-stay psychogeriatric wards. In: Flax HJ, Matta AA, eds. *New Frontiers that Influence Disease and Rehabilitation, IRMA IV, Puerto Rico, 1983*, pp.125-129.
- Watomori T, Eto F. A longitudinal study of linguistic and nonlinguistic functions in a patient with Alzheimer's disease. *Rinshou Seishin Igaku (Clin Psychiatry)* 12: 1155-1168, 1983.
- Eto F, Harasawa M, Hirai S. Hand dexterity related to age: Pegboard test as an indicator of aging and brain dysfunction. *Jpn J Geriat* 20: 405-409, 1983.
- Eto F, Yoshikawa M. A dose-response study of Dihydroergotoxine (DHET) Mesylate for cerebrovascular disturbances. In: Gaitz CM, Samorajski Y, eds. *Aging 2000: Our Health Care Destiny, vol 1: Biomedical Issues, Springer-Verlag, New York, 1985*, pp.421-431.
- Ueda S, Hasegawa T, Ando K, Sakuma A, Kusunoki T. Standardization of the finger function test and upper extremity ability test for hemiplegia. *Jpn J Rehabil Med* 22: 143-160, 1985.
- Okawa Y, Ueda S, Eto F, Kikuchi N. The analysis of the course of motor impairment in Fukuyama type congenital muscular dystrophy. *Jpn J Rehabil Med* 22: 197-202, 1985.
- Okawa Y, Eto F, Ueda S. The analysis of the course of disability in Werdnig-Hoffman disease (chronic type). *Jpn J Rehabil Med* 22: 115-120, 1986.
- Eto F. Treatment of degenerative neurological diseases in the elderly: a rehabilitation approach. *Jpn J Geriat* 23: 35-40, 1986.
- Eto F. Rehabilitation of post-stroke patients with cardiac disease. *J Clinical and Experimental Medicine (Igaku no ayumi)* 139: 691-695, 1986.
- Ueda S, Eto F, Okawa Y. Standardization of a functional test for hemiplegia for the evaluation of total body motion. *Scand J Rehabil Med* 17 (Suppl): 163, 1988.
- Eguchi K, Eto F, Ohkawa Y, Ueda S. Factors affecting return to work following stroke in youth and young adults. *Jpn J Stroke*. 10: 124-126, 1988.
- Eto F. Physical disability and dementia. *Jpn J Rehabil Med* 25: 85-86, 1988.
- Eto F. Rehabilitation of the elderly patients. In: Hsu C-J, Orimo H, eds. *Problems of the aged. Asia &*

- Pacific Council for Science & Technology, Taipei, 1989, pp64-88.
19. Majima M, Ueda S. Major factor of the deterioration of physical fitness in poststroke hemiplegics. *Jpn J Rehabil Med* 27: 53-57, 1990.
 20. Eto F. Activities of daily living and mental status in elderly patients with organic brain disorders. In: O'Neill D ed. *Carers, Professionals and Alzheimer's Disease*, John Libbey & Company, London, 1991, pp323-327.
 21. Eto F. Falls and immobilization: A vicious circle in the elderly. In: Orimo H, Fukuchi Y, Kuramoto K, Iriki M eds. *New Horizons in Aging*, Univ of Tokyo Press, Tokyo, 1992, pp.280-281.
 22. Eto F, Tanaka M, Mizoguchi T. Comprehensive activities of daily living (ADL) index for the elderly. In Beregi E, Gergely IA, Rajczi K, eds.: *Recent Advances in Aging Science*, vol.2, Monduzzi Editore, Bologna, 1993, pp.2183-2187.
 23. Obana M, Eto F. Progressive pes equinovarus complicated with Parkinson's disease. *J Clin Rehabil* 2: 78-80, 1993.
 24. Kakurai S, Akai M. Clinical experiences with a convertible thermoplastic knee-ankle-foot orthosis for post-stroke hemiplegic patients. *Prosthetics and Orthotics International* 20:191-194, 1996.
 25. Eto F, Saotome I, Akiya N, Furuichi T. Early intervention of rehabilitation service for acute stroke patients. *Eur J Neurol* 3(Suppl 2): 102, 1996.
 26. Akai M, Shirasaki Y, Tateishi T. Electrical stimulation on joint contracture; an experiment in rat model with direct current. *Arch Phys Med Rehabil* 78:405-409, 1997.
 27. Eto F. Rehabilitation of memory. *Jpn J Rehabil Med* 34: 395-399, 1997.
 28. Akai M, Usuba M, Maeshima T, Shirasaki Y, Yasuoka S. Laser's effect on bone and cartilage change induced by joint immobilization; An experiment with animal model. *Lasers in Surgery and Medicine* 21:480-484, 1997.
 29. Kodama Y, Nakayama K, Fuse H, Fukumoto S, Kawahara H, Takahashi H, Kurokawa T, Sekiguchi C, Nakamura T, Matsumoto T. Inhibition of bone resorption by pamidronate cannot restore normal gain in cortical bone mass and strength in tail-suspended rapidly growing rats. *J Bone Miner Res* 12: 1058-1067, 1997.
 30. Usuba M, Akai M, Shirasaki Y. Effect of Low-Level Laser Therapy (LLLT) on viscoelasticity of the contracted knee joint; Comparison with whirlpool treatment in rats. *Lasers in Surgery and Medicine* 22:81-85, 1998.
 31. Yokota K, Itsukaichi K, Kakurai S, Asakura K. Consideration of training for walker-assisted gait: From the investigation of the load under walker's tips. *Bull Jpn Soc Prosthetics Orthotics* 14: 76-81, 1998.
 32. Itsukaichi K, Kaneko H, Kakurai S, Tazawa E. Habilitation of the congenital limb deficient children. *Bull Jpn Soc Prosthetics Orthotics* 14: 88-94, 1998.
 33. Eto F, Saotome I, Furuichi T, Ogasawara M. Effects of long-term use of benzodiazepines on gait and standing balance in the elderly. *Annals of New York Academy of Sciences* 860: 543-545, 1998.
 34. Kodama Y, Takeuchi Y, Suzawa M, Fukumoto S, Murayama H, Yamato H, Fujita T, Kurokawa T, Matsumoto T. Reduced expression of interleukin-11 in bone marrow stromal cells of senescence-accelerated mice (SAMP6): relationship to osteopenia with enhanced adipogenesis. *J Bone Miner Res* 13: 1370-1377, 1998, 1999.
 35. Miyake N, Yanagihara K, Sindo N. House work of female stroke patients. *Jpn J Rehabil Med* 36: 644-648, 1999.
 36. Kodama Y, Dimai HP, Wergedal J, Sheng M, Malpe R, Kutilek S, Beamer W, Donahue LR, Rosen C, Baylink DJ, Farley J. Cortical tibial bone volume in two strains of mice: effects of sciatic neurectomy and genetic regulation of bone response to mechanical loading. *Bone* 25: 183-190, 1999.
 37. Linkhart TA, Linkhart SG, Kodama Y, Farley JR, Dimai HP, Wright KR, Wergedal JE, Sheng M, Beamer WG, Donahue LR, Rosen CJ, Baylink DJ. Osteoclast formation in bone marrow cultures from two inbred strains of mice with different bone densities. *J Bone Miner Res* 14: 39-46, 1999.
 38. Eto F. Recent advances in geriatric rehabilitation. *Jpn J Geriat* 36: 153-161, 1999.
 39. Xu H, Akai M, Kakurai S, Yokota K, Kaneko H. Effect of shoe modifications on center of pressure and in-shoe plantar pressures. *Am J Phys Med Rehabil* 78:516-524, 1999.
 40. Fujitani J, Ishikawa T, Akai M, Kakurai S. Influence of daily activity on changes in physical fitness for people with post-stroke hemiplegia. *Am J Phys Med Rehabil* 78:540-544, 1999.
 41. Akai M, Shirasaki Y, Tateishi T. The effect of electricity on joint contracture due to immobilization; Direct current stimulation in rat experiment. In: *Electricity and Magnetism in Biology and Medicine*. Bersani F ed., Kluwer Academic/Plenum Publishers, New York, 1999, p.883-886.
 42. Honda F, Akai M, Itsukaichi K, Kakurai S, Tazawa E. A report on progress of trainings and obtained activities about electronic prosthesis fitting for the congenital limbs deficient child. *Sagyo Ryoho (J Jpn Ass OT)* 18: 478-487, 1999.
 43. Nara A, Umishima M, Imase A, Mineshima T. Study on the effects of pulp-to-pulp distance in measuring the pinch strength - compare the young with the aged in a nursing home -. *Sagyo Ryoho (J Jpn Ass OT)* 19: 338-345, 2000.
 44. Hirose K, Eto F. Exercise training for internal disability in the elderly. *J Clin Rehabil* 9: 342-350, 2000.
 45. Eto F, Sakata T. Influential factors on health-related quality of life after cerebral vascular disease. *Jpn J Geriat* 37: 554-560, 2000.
 46. Kodama Y, Miyakoshi N, Linkhart TA, Wergedal J, Srivastava A, Beamer W, Donahue LR, Rosen C, Baylink DJ, Farley J. Effects of dietary calcium deple-

- tion and repletion on dynamic determinants of tibial bone volume in two inbred strains of mice. *Bone*. 27: 445-452, 2000.
47. Kodama Y, Umemura Y, Nagasawa S, Beamer WG, Donahue LR, Rosen CR, Baylink DJ, Farley JR. Exercise and mechanical loading increase periosteal bone formation and whole bone strength in C57BL/6J mice but not in C3H/HeJ mice. *Calcif Tissue Int*. 66: 298-306, 2000.
 48. Eto F. Causes of falls in the elderly. *Japan Medical Association Journal* 44: 299-305, 2001.
 49. Ohtsuru I, Eto F, Wada N, Saotome I, Furuichi T. New reliable and valid motor assessment scale for stroke patients: Hemiplegic motor behavior tests. *Geriatrics Gerontology Int* 1: 45-51, 2001.
 50. Kodama Y, Eto F. How to find out patients with a high risk for falls. *J Clin Rehabil* 10: 961-964, 2001.

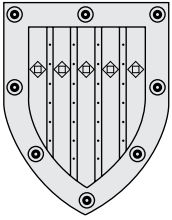

Department of Anesthesiology

Outline and Research Objectives

The department of Anesthesiology was established in 1952. Our department has residents and eight researchers from China. We give lectures and provide clinical education for postgraduate students and medical students.

We have pain clinic services in our department, which was established in 1962. It is provided for not only out-patients but also including patients in the ward of the other departments on a daily basis in all areas of painful diseases.

Anesthesia service including pre-and post-operative care is provided every day for elective and emergency surgical procedures. Recently, we have started acute pain service for postoperative pain relief and palliative medicine for cancer pain relief and terminal care.

Research activities:

There are eight laboratories in our department, which are investigating clinical and basic project of anesthesia research.

These themes of the research groups of our department are listed as below.

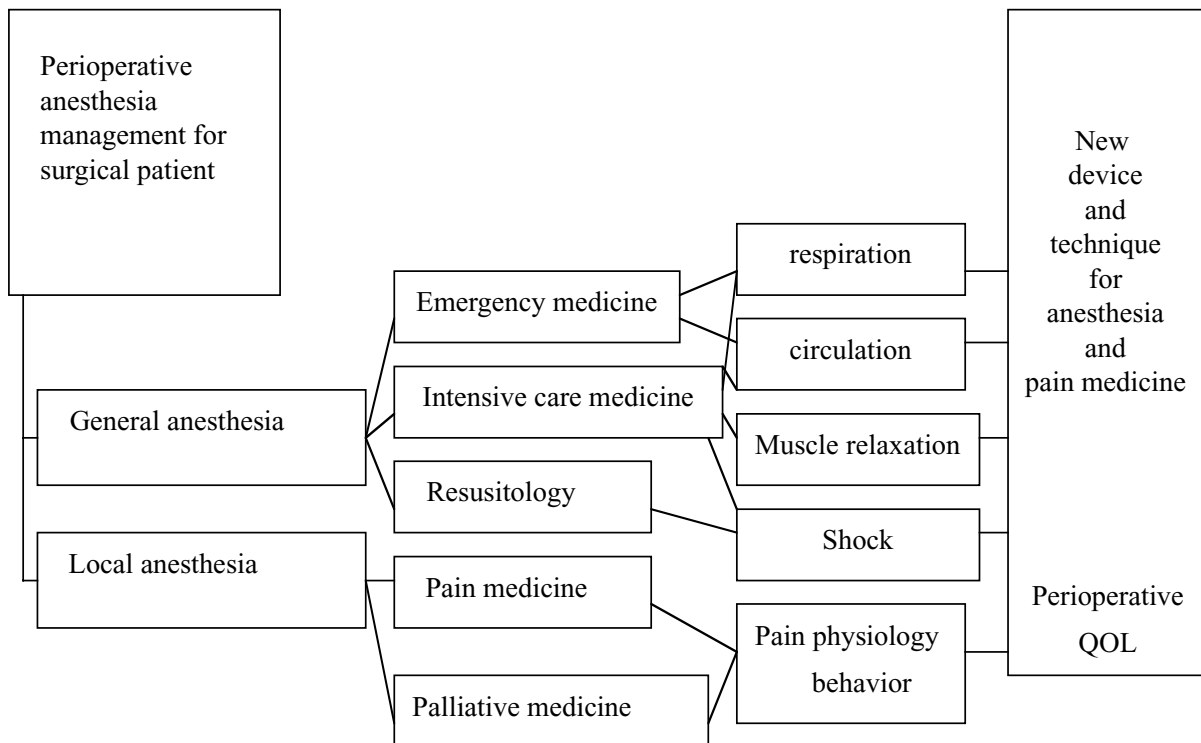

Anesthesiology, basic and clinical respiration

- Measurement of pulmonary vascular resistance of normal and pulmonary edema using rabbit
- The effect of anesthetics upon pulmonary function
- The model of neurogenic pulmonary edema of rabbit
- Basic research of lipopolysaccharide which interact with apoprotein from the lung of neonatal mouse
- Basic research of the changes in transmission and distribution of gas with pulmonary lesion
- Clinical assessment of pulse-oximeter

circulation

- Relationship between sympathetic nervous system and cardiac function
- Clinical assessment of anti-hypertensive agents during anesthesia
- Prostaglandins and tissue blood flow of the liver and kidney

pain mechanism (neurobiology, neuro-physiology, behavior investigation)

- Relationship between noxious stimuli and catecholamines in the anesthetized rat
- Physiology of pain and the mechanisms of analgesia using spinal rat
- The effect of midazolam upon the spinal analgesical mechanisms
- The effect of peripheral sensory nervous activities by acupuncture
- Basic and clinical assessment of benzodiazepine antagonist
- Basic and clinical assessment of enkephalinase inhibitor
- Analgesic mechanism of nociceptin in spinal rat
- Assessment of bispectral index monitor
- Clinical evaluation of drug challenge test
- Analgesic mechanism of laser treatment
- Analgesic mechanism of oriental medicine
- Clinical assessment of acupuncture

muscle relaxation

- Mechanism and the pharmacological analysis of non-depolarizing muscle relaxants in human
- Clinical assessment of malignant hyperthermia
- Basic and clinical assessment of non-depolarizing muscle relaxants

new devices and techniques for anesthesia

- Mechanism of H-type epidural-spinal anesthesia
- Development of skin surface anesthetics by lidocaine tape
- Clinical assessment of the induction by midazolam combined with barbiturates
- Anesthetic method by low dose buprenorphine with inhalational anesthetics
- The effect of epidural buprenorphine and morphine on post-operative pain control
- Clinical usefulness of patient-controlled analgesia (PCA)
- Clinical assessment of stellate ganglion block
- Assessment of anesthetic machines
- Development of device for intubation

mechanism of anesthesia

- Mechanism of anesthetics from auditory brainstem response and Fourier analysis of EEG
- Inhalational anesthetics and rate potential
- Analgesic mechanisms of hyperventilation
- The interaction of central analgesic and spinal analgesic mechanisms

shock

- Response to immunological system against the endotoxin in the blood
- The effect of poly-enzyme inhibitor upon tissue microcirculation
- Effects of anesthetics upon liver cell and Kupffer cell

QOL in surgical patients during perioperative period and chronic pain patients

- Perioperative QOL in case of surgical patient
- QOL of donor of blood
- QOL of intractable chronic pain patient such as post-herpetic neuralgia and low back pain

Faculty and Students

Professor and Chair	Kazuo Hanaoka, MD, Ph., D. (1991~)
Associate Professors	Hideko Arita, MD, Ph.,D. Tomoki Nishiyama MD, Ph., D
Lecturer	Cyoku Yajima, MD, Ph., D Yasuo Ide, MD, Ph.,D. Masakazu Hayasida MD, Ph.,D.
Associate	13
Postdoctoral Fellow	12
Graduate student	9
Research student.....	6
Secretary	3

Past Research and Major Accomplishments

In Anesthesiology, Respiration, Circulation, Pain, Muscle relaxation, New devices and techniques for anesthesia, Mechanism of anesthesia, Shock and Perioperative QOL are mainly involved.

For each project, we are investigating both basicly and clinically. The main purpose of these investigation is that the safety and quality of perioperative anesthesia care are sought, and also the treatments of patients with intractable pain as chronic pain and postoperative pain as acute pain are important field of pain management.

We investigated the effect of Drug Challenge Test (DCT) for chronic intractable pain patient and established the easy and accurate method of DCT. This DCT were applied to many chronic patients and got good results by the treatment of administered adequate drugs orally. Epidurascopy for chronic lumbar pain are investigated and developed clinically.

Postoperative pain management are also investigated and established guideline for the method using local anesthetics combined with narcotics via epidural catheter to the epidural space. Patient Controlled Analgesia (PCA) and pre-emptive analgesia are also investigated.

Current Research

Respiration, circulation, pain, muscle relaxation, new devices and techniques for anesthesia, mechanism of anesthesia, shock and perioperative QOL are being investigated. Each project is progressing well. Especially new devices for epiduroscopy with useful attachment such as manipulating device are being developed.

We are making of the animal model of post herpetic neuralgia (PHN), which is very useful for the investigation of PHN. The number of patients with PHN will increase because of large population of high aged people in the near future. Therefore, this is very important investigation.

Future Project

We are seeking the method of safe anesthesia including perioperative period. Also safe management of pain is really necessary in 21 century, because the population of aged people will be tremendously increased. Therefore, the investigated area of above mentioned will be continued. Palliative care medicine will be important field also in the near future. Therefore, we will investigate this field. Actually clinical investigation of palliative care medicine has started from this year as a field study.

Research Grants

1. 1998-2001 Research Grant (C2), #10671404 The Involvement of NMDA receptor in the intrinsic analgesia evoked by hyperventilation.
2. 1998-2001 Research project. Grant-in-aid for scientific research (B)#10470315 The effects of vasoactive drugs upon the spinal pain modulation.
3. 1999-2002 Research Grant (C2), #11671480 The effects of inhalational anesthetics and nitric oxide upon the activities of spinal dorsal horn neuron.
4. 2000-2002 Research Grant (C2), #12671453 Investigation of network by analgesic mechanisms of spinal cord
5. 2002-2004 Research Grant(C2), #14571422 The development and clinical application of cheeper and more accurate neuromuscular monitoring devices now in use.

Select Publications

respiration

1. Kitamura T, Uchida K, Tanaka N, Tsuchiya T, Watanabe J, Yamada Y, Hanaoaka K, Seymour JF, Schoch OD, Doyle I, Inoue Y, Sakatani M, Kudoh S, Azuma A, Nukiwa T, Tomita T, Katagiri M, Fujita A, Kurashima A, Kanagasaki S, Nakata K: Serological diagnosis of idiopathic pulmonary alveolar proteinosis. *American Journal of Respiratory & Critical Care Medicine* 162:658-662, 2000

circulation

2. Nishiyama T, Hanaoaka K.: Nicardipine did not activate rennin-angiotensin- aldosterone system during isoflurane or sevoflurane anesthesia. *Canadian Journal of Anaesthesia* 47(12):1249-1252, 2000
3. Nishiyama T, Hanaoaka K: Free hemoglobin concentrations in patients receiving massive blood transfusions during emergency surgery for trauma. *Canadian Journal of Anaesthesia* 47(19): 881-885, 2000
4. Nishiyama T, Yokoyama T, Matsukawa T, Hanaoka K: Continuous nicardipine infusion to control blood

pressure after evacuation of acute cerebral hemorrhage. *Canadian Journal of Anaesthesia* 47(12):1196-1201,2000

5. Orii R, Sugawara Y, Hayashida M, Yamada Y, Kubota K, Takayama T, Harihara Y, Makuuchi M, Hanaoaka K: Peri-operative blood lactate levels in recipients of living-related liver transplantation. *Transplantation* 69(10):2124-7, 2000
6. Takeda K, Sawamura S, Tamai H, Hagihara R, Hanaoaka K: Reversible tricuspid valve obstruction during removal of renal cell carcinoma with intracardiac tumor extension. *Anesthesia & Analgesia* 91:1137-38, 2000
7. R. Orii, Y. Sawamura, M. Hayashida, Y. Yamada, K. Chang, T. Takayama, M. Makuuchi and K. Hanaoaka: Effects of amrinone on ischaemia-reperfusion injury in cirrhotic patient undergoing hepatectomy: a comparative study with prostaglandin E₁. *British Journal of Anaesthesia* 85(3): 389-95, 2000
8. Orii R, Sugawara Y, Hayashida M, Uchida K, Yamada Y, Takayama T., Makuuchi T., Hanaoaka K: Lactate is correlated with the indocyanine green elimination rate in liver resection for cirrhotic patients. *Anesthesia & Analgesia* 92(4):1064-070,2001
9. Kazuo Hanaoaka, Akiyoshi Namiki, Shiji Dohi, Yoshihisa Koga, Osafumi Yuge, Yasushi Kayanuma, Kazuyuki Hidaka, Tadashi Kusunoki; A dose-ranging study of midazolam for postoperative sedation of patients: A randomized, double-blind, placebo-controlled trial. *Crit Care Med.* 30 (6): 1256-1260, 2002
10. Masakazu Hayashida, Mieko Chinzei,, Haruko Fujiwara, Kyoko Komatsu, Hisako Usui, Kanji Uchida, Toshiya Tomioka, Kazuo Hanaoaka: Bispectral Index as an Indicator of Cerebral Function during Surgery Using Deep Hypothermia and Circulatory Arrest. *Cardiovascular Anaesthesia* 6(1): 9-13, 2002

pain mechanism (neurobiology, neuro-physiology, behavior investigation)

11. Tomoki Nishiyama, Takeshi Yokoyama, Kazuo Hanaoaka: Midazolam improves postoperative epidural analgesia with continuous impression of local anesthetics. *Canadian Journal of Anaesthesia* 45(6) : 551-555, 1998
12. T. Nishiyama and K. Hanaoaka: Effect of diluent volume on post-operative analgesia and sedation produced by epidurally administered Midazolam. *European Journal of Anesthesiology* 15: 275-279, 1998
13. T. Nishiyama, T. Matsukawa and K. Hanaoaka: Continuous epidural administration of Midazolam and Bupivacaine for postoperative analgesia. *Acta Anaesthesiologica Scandinavica* 43 : 568-572, 1999
14. Tomoki Nishiyama, Takashi Matsukawa, Kazuo Hanaoaka: Acute Phase Histopathological Study of Spinally Administered Midazolam in Cats. *Anesthesia & Analgesia.* 89: 717-20, 1999
15. Hanaoaka k, Hayashida M, Arita H, Sumida T, Ide Y: Management of Postoperative Pain. The

Management of Acute and Chronic Pain The Use of the Tools of Trade: 133-137,2000

16. Hanaoaka K, Meno A, Arita H, Tamai H, Orii R, Sumida T: Drug Challenge Tests in Chronic Pain Management. *The Management of Acute and Chronic Pain The Use of the Tools of Trade:* 345-349,2000
17. H. Sekiyama, J Utsumi, S G Shimada, H Nagase and Meno A, Arita H, Hanaoaka K: The Efficacy of Drug Challenge Test (DCT) in the Treatment of Pain Attributable to Brachial Plexus Avulsion, *Management of Pain. World Perspective:*183-186, 2000
18. Nishiyama T, Hanaoaka K: The effects of epidural bupivacaine, morphine, and their combination on thermal nociception with different stimulus intensity in rats. *Anesthesia & Analgesia* 91(13) :652-656, 2000
19. Arita H, Meno A, Zhang L, Hanaoaka K: The CPT and Drug Treatment for Brachial Plexus Avulsion, *Management of Pain. A World Perspective:*115-8, 2000
20. Nishiyama T, Gyermek L, Lee C, Kawasaki -Yatsugi S, Yamaguchi T, Hanaoaka K: The analgesic interaction between intrathecal clonidine and glutamate receptor antagonists on thermal and formalin-induced pain in rats. *92 Anesthesia & Analgesia (3): 725-732,2001*
21. Hanaoaka K: Drug Challenge Tests in Chronic Pain Patients. The role of catecholamines and other neuromediators in neuropathic pain. *Proceeding of the Satellite Symposium of the 9th International Catecholamines Symposium:* 69- 81,2001
22. Toshiya Tomioka, Yutaka Awaya, Kenji Nihei and Kazuo Hanaoaka: Post- Herpetic neuralgia in a patient with congenital insensitivity to pain and anhidrosis *Journal of Anesthesia* 16(1): 84-6,2002
23. S. Swamura, T. Tomioka, and K. Hanaoaka: The Importance of Tail temperature monitoring during tail-flick test in Evaluating the antinociceptive action of volatile anesthetics. *Acta Anaesthesiologica Scandinavica* 46:451-4, 2002
24. Hanaoaka K., Hayashida M., Arita H., Sumida T., Ide Y.: How to Set up an Acute Pain Service. *Japan Perspective, Recent Views on Clinical Pain* Edited by Varrassi G. Monduzzi Editor, Bologna: 93-97, 2002
25. Min Dai, Toshinobu Sumida, Megumi Tagami, Yasuo Ide, Masaki Nagasae, Hiroshi Sekiyama and Kazuo Hanaoaka: Suppressive effect of spinal dorsal-horn neuronal activity by local spinal-cord cooling in reversed by naloxone in cats. *Journal of Anesthesia* 16: 211-15, 2002
26. Li WM., Wu GC., Arita H., Hanaoaka K.: Acupuncture stimulation inhibits somato-renal sympathetic A- and C-reflexes in anesthetized rats. *Acupuncture & Electro-Therapeutics Research* 27(2): 119-27, 2002.

muscle relaxation

27. Hideto Oyamada, Keiko Oguchi, Naoto Saitoh, Toshiko Yamazawa, Kenzo Hirose, Yoko kawara,

Kazunao Wakatsuki, Katsuji Oguchi, Megumi Tagami, Kazuo Hanaoka, Makoto Endo, and Masamitsu Iino: Novel Mutations in C-terminal channel Region of the Ryanodine Receptor in Malignant Hyperthermia Patients. *Jpn. J. Pharmacol.* 88:159-166, 2002

new devices and techniques for anesthesia

28. Tomoki Nishiyama, Takashi Matsukawa, Kazuo Hanaoka: The Effect of Age and Gender on the Optimal Premedication Dose of Intramuscular Midazolam. *Anesthesia & Analgesia* 86: 1103-1108, 1998
29. T. Nishiyama, N. Sugai and K. Hanaoka: In vitro Changes in the Transparency and PH of Cerebro Spinal Fluid Caused by Adding Midazolam. *European Journal of Anaesthesiology* 15: 27-31, 1998
30. Tomoki Nishiyama, Hideto Nakayama, Kazuo Hanaoka, Sevoflurane or Thipotenol-Isflurane for Induction and Laryngeal Mask Insertion? Comparison by Side Effects; Hemodynamics, and Spectral analysis of Heart Rate Variability. *Anesthesia and Resuscitation* 35(2) : 99-103, 1999
31. Takayuki Kitamura, Yoshitugu Yamada, Hong-Lin Du, Kazuo Hanaoka: Efficiency of a New Fiberoptic Stylet Scope in Tracheal Intubation. *Anesthesiology* 91(6) :1628-1632, 1999
32. Kitamura T, Yamada Y, Du HL, Hanaoka K: An efficient technique for tracheal intubation using the Stylet Scope alone. *Anesthesiology* 92(4) :1210-1211, 2000
33. T. Kitamura, Y. Yamada, M. Chinzei, H.L. Du and K. Hanaoka: Attenuation of hemodynamic responses to tracheal intubation by the Stylet Scope. *British Journal of Anaesthesia* 86(2):275-277, 2001
34. Kato, M. Sugiyama, Y. Orii, R. Hayashida, M. Kaneko, J. Takayama, T. Hanaoka, K. Makuuchi, M. : Lactate levels in cirrhotic patients undergoing liver resection. *Hepato-Gastroenterology* 48 (40):1106-9, 2001
35. Toshiya Tomioka, Yutaka Awaya, Kenji Nihei, Hiroshi Sekiyama, Shigehito Sawamura, Kazuo Hanaoka : Anesthesia for Patients with Congenital Insensitivity to Pain and Anhidrosis: A Questionnaire Study in Japan. *Anesthesia & Analgesia* 94:271-274, 2002
36. Nobuhide Kin, Masakazu Hayasida, Kyung-ho Chang, Kanji Uchida, Kazuo Hanaoka: External manual compression of the abdominal aorta to control hemorrhage from a ruptured aneurysm. *Journal of Anesthesia* 16: 164-6, 2002
37. Tomoki Nishiyama, Takashi Mastukawa, Kazuo Hanaoka: Effects of adding Midazolam on the Postoperative Epidural Analgesia with Two Different Doses of Bupivacaine. *Journal of Clinical Anesthesia* 14: 92-7, 2002
38. Nishiyama T., Misawa K., Yokoyama T., Hanaoka K.: Effects of combining Midazolam and Barbiturate on the response to tracheal intubation : changes in autonomic nervous system. *Journal of Clinical Anesthesia* 14(5):344, 2002

39. Nishiyama T., Hanaoka K., Ochiai Y.: The median approach to transsacral epidural block. *Anesthesia & Analgesia* 95(4): 1067-70, 2002
40. Tomoki Nishiyama, Takashi Mastukawa, Takeshi Yokoyama, Kazuo Hanaoka: Rapid Inhalation Induction with 7% Sevoflurane Combined with Intravenous Midazolam. *Journal of Clinical Anesthesia* 14:290-295, 2002

mechanism of anesthesia

41. Sawamura S, Kingery WA, Davies MF, Agashe G, Clark DJ, Kobilka BK, Hashimoto T, Maze M: Antinociceptive action of nitrous oxide is mediated by stimulation of noradrenergic neurons in the brainstem and activation of alpha 2B adrenoceptors. *Journal of Neuroscience* 20:9242-9251, 2000

shock

42. T. Nishiyama, T. Yokoyama and K. Hanaoka: Effects of sevoflurane and isoflurane anesthesia on arterial ketone body ratio and liver function. *Acta Anaesthesiologica Scandinavica* 43: 347-351, 1999
43. Nishiyama T, Hanaoka K: A traumatic asphyxia in a child. *Canadian Journal of Anaesthesia* 47:1099-1102, 2000
44. Nishiyama T, Matsukawa T, Hanaoka K: Is protease inhibitor a choice for the treatment of pre- or mild disseminated intravascular coagulation? *Critical Care Medicine* 28:1419-22, 2000
45. Takayuki Kitamura, Yoshitsugu Yamada, Yoshifumi Beck, Sae Asai, Hong-Lin Du and Kazuo Hanaoka: Postoperative left recurrent laryngeal nerve palsy possibly caused by coincidental swelling of the metastatic mediastinal lymph node. *Journal of Anesthesia* 14(4):216-7, 2000
46. Nishiyama T, Hanaoka K: Hemolysis in stored red blood cell concentrates: modulation by haptoglobin or ulinastatin, a protease inhibitor. *Crit Care Med.* 29 (10):1978-82, 2001
47. Nishiyama T, Hanaoka K: Do the effects of a protease inhibitor, ulinastatin, on elastase release by blood transfusion depend on interleukin 6? *Crit Care Med.* 29(11): 2106-2110, 2001
48. Nishiyama T, Hanaoka K: Propofol-induced bronchoconstriction: two case reports. *Anesthesia & Analgesia* 93 (3): 645-646, 2001

QOL pre-operation

49. Mina Nishimori, Akiko Takeoka, Arinobu Tojyo, Yasuo Nakano, Yoshitsugu Yamada and Kazuo Hanaoka: Self-reported recovery time of daily activity after bone marrow harvesting from healthy donors. *Journal of Anesthesia* 15:1-5, 2001
50. Mina Nishimori, Nelly Moerman, Shunichi Fukuhara, F. S. A. M. Van Dam, M.J. Muller, Kazuo Hanaoka & Yoshitsugu Yamada: Translation and validation of the Amsterdam preoperative anxiety and information scale (APAIS) for use in Japan. *Quality of Life Research* 11: 361-4, 2002

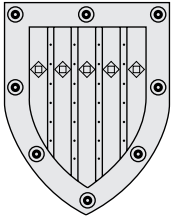

Department of Emergency and Critical Care Medicine

Outline

Department of Emergency and Critical Care Medicine was established in 1965, as the emergency service within the Central Clinical Service Facilities of the University of Tokyo Hospital and at the same time as the intensive care service for in-hospital patients, it became a tertiary emergency care and critical care center in the metropolitan Tokyo and also became the principal teaching facility of the University of Tokyo. It is a designated Level I Trauma Center, and also the home of one of the newest Life Flight aeromedical services in the country.

The Emergency Center sees approximately 15000 patients per year. It contains major trauma and cardiac resuscitation rooms complete with STAT X-ray and full monitoring and resuscitation equipment. There are 9 treatment spaces including space for orthopedic, gynecology, and optho-ENT evaluation. X-ray, rapid spiral CT, ultrasound, angiography and STAT Lab are located adjacent to the Emergency Center.

The Critical Care Center contains adult intensive care unit (ICU) of 8 beds, cardiac care unit (CCU) of 6 beds, surgical high care unit (SHCU) of 36 beds, medical high care unit (MHCU) of 15 beds, pediatric intensive care unit (PICU) of 6 beds, and neonatal intensive care unit (NICU) of 6 beds.

The Emergency Center and Critical Care Center sees an excellent mix of multiple traumas, high-acuity medical, surgical, pediatric, and gynecological patients. The Life Flight service provides another opportunity for exposure to critically ill patients. Consult services are available from each of the clinical departments of the Hospital.

Faculties and Students

Professor and Chairman Naoki YAHAGI, M.D., Ph.D.
 Associates9
 Staff3
 Research student.....1
 Secretaries3

Past Research and Major Accomplishments

- Study of the effect of anesthetics on the threshold for transpulmonary passage of venous air emboli. (*Resuscitation* 13: 81-86, 1986, *Anesthesiology* 67: 905-909, 1987, *Anesth Analg* 75: 720-723, 1992).

We found that the threshold for transpulmonary passage of venous air was significantly lower during halothane anesthesia (0.01-0.05 ml/kg), as compared with pentobarbital (1.0

ml/kg), fentanyl (0.5 ml/kg), or ketamine (0.35 ml/kg) anesthesia.

- Study on the effect of catecholamine on regional cerebral blood flow in dogs (Masui 36: 1176-1180, 1986)

Development of Hemoperfusion System (HF)

- 1) For the patients of cardiac surgery
- 2) For the regulation of water balance in the patients of renal insufficiency
- 3) For the expansion of the indication of bloodless priming for cardiopulmonary bypass by hemoconcentration using HF.



The usage of HF during cardiopulmonary bypass in NCVC

	1985	1986	1987	1988	1989	1990	
Total		644	623	593	573	586	594
HF		13	78	115	84	120	180
HF in adults (%)		2.0	9.0	12.0	7.8	11.6	16.3
HF in infants (%)		0.0	3.5	5.4	7.0	8.9	14.0

- Development of HF pump system for the perioperative management of cardiac surgical patients suffering from renal insufficiency and deteriorated cardiac function. (Ube-Junken; 1984)
- Induction of hypothermia for the management of the patient who undertaken open heart surgery complicated by acute cerebral infarction (Kyukyugaku 18:917-921, 1994) (1984).
- We elucidated the structural parts involved in activation and inactivation of Na channel by bioengineering and electrophysiology. (*FEBS Letters* 228: 195-200, 1987, *Nature* 339: 597-603, 1989).
- Effect of low molecular weight dextran for ARDS induced by oleic acid (*Am J Emerg Med* 18: 180-183, 2000)(1988).
- Yahagi cared 5300 cases of critically ill patients including cardiac surgical patients, severely ill patients of all categories in NCVC, and emergency cases. Yahagi developed a handy bronchofiberscope. (Easyscope:FiberTech, 21000BZZ00571000, 1998). Yahagi engaged in the preparation of a manual for cardiac transplantation, and established The International Society of Medical Gas in 1995.
- Induction of mild hypothermia for the management of severe cardiac insufficiency (*Anesth Analg* 79: 581-582, 1994, *J Clin Anesth* 10: 120-125, 1998) (1991)

Evaluation of Airway

- 1) Effect of change of position (*Ann Thorac Surg* 67: 894, 1999)
- 2) Ultrasound detection of diaphragmatic paralysis after cardiac operations (*Ann Thorac Surg* 65: 1841, 1998)
- 3) Double lumen endobronchial tube Broncho-Cath II (*Anesthesiology* 81: 781-782, 1994)
- 4) The cause for needing airway maneuvers to maintain a patent airway during the use of cuffed oropharyngeal airway (COPA) using endoscope, and the difficulty of maintaining patent airway during COPA use might by collapse of the larynx at the level of the hyoid bone. (*Resuscitation* in press)
- 5) Diagnosis of airway obstruction (*Anesth Analg* 76: 207, 1993, *Anaesthesia* 50: 91-92, 1995, *Anesth Analg* 85: 1180-1181, 1997)
- 6) Bronchial lavage of the infant using a laryngeal mask airway (*Anaesthesia* 49: 450, 1994) (*Anaesthesia* 49: 450, 1994)
- 7) Development of a handy-type bronchofiberscope

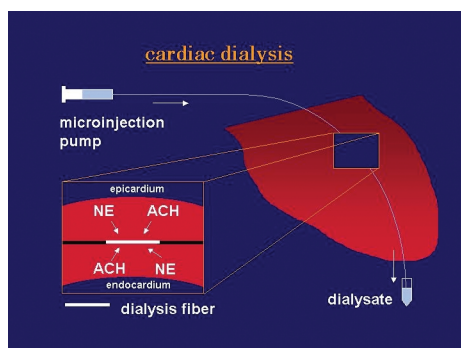

Inhaled nitric oxide (NO)

- 1) Indication and the 2-4years follow up of the cases (*Artif Organs* 21: 17-20, 1997, *Artif Organs* 21: 83-84, 1997, *Artif Organs* 22: 886-891, 1998, *Artif Organs* 23: 169-174, 1999)

83 patients (1993.9.~1995.12.)

- 1) PH (n=32; 21children, 11 adults)
- 2) severe PH crisis (n=9)
- 3) high Rp after aortopulmonary shunt (n=4)
- 4) RV dysfunction (n=2)
- 5) PAP ≥ 15 mmHg and TPG ≥ 10 mmHg (n=18)
- 6) RV dysfunction in Patients with LVAS (n=4)
- 7) impaired oxygenation (n=14)

- 2) Fontan type operation (*Ann Thorac Surg* 57: 1371-1372, 1994)
- 3) LVAS (*Artif Organs* 19: 557-558, 1995, *Ann Thorac Surg* 65: 345, 1998)

- Helium inhalation (*Anesth Analg* 80: 1042-1045, 1995, *Artif Organs* 21: 24-27, 1997) We demonstrated the beneficial effect of helium/oxygen to improve oxygenation of the postcardiac surgical patients who showed impairment of oxygenation without physiological findings and with normal chest radiographs despite having a positive end expiratory pressure of up to 10 cmH₂O.

The effect of helium-oxygen on oxygenation and lung parameters

min		-90 min	baseline	He 90 min
56*	PaO ₂ /FiO ₂	117 ± 45	113 ± 39	174 ± 56*
± 5*	Qs/Qt (%)	27 ± 7	29 ± 6	19 ± 5*
18*	Cdyn (ml/cm H ₂ O)	60 ± 18	60 ± 18	65 ± 18*
± 4	PIP (cm H ₂ O)	25 ± 4	25 ± 3	25 ± 4

*: p<0.05 vs baseline values.

- Autotriggering caused by cardiogenic oscillation during flow-triggered mechanical ventilation (*Crit Care Med* 28: 402-407, 2000)
- Clinical use of electrolyzed water (*Artif Organs* 21: 39-42, 1997, *Artif Organs* 24:984-987, 2000).
- Elucidation of peripheral neural regulation of heart (*Brain Res* 761: 329-332, 1997, *J Autonom Nerv System* 68: 43-48, 1998, *Brain Res* 794: 146-150, 199, *Brain Research* 864: 157-161, 2000)

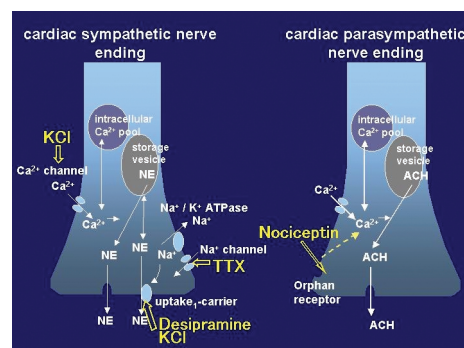

Current Research and Future Prospects

We are now concentrating to develop "the Vital Care Network System" which is to manage the great number of high risk people continually. The system is composed of wearable monitor, wrist watch type PHS which is to amplify the signal, the information center to receive and manage the vital sign signals and to call on hospitals for aid. (The Next Generation Software Project of Information-technology Promotion Agency, Japan. "Vital Care Network System". 2002)

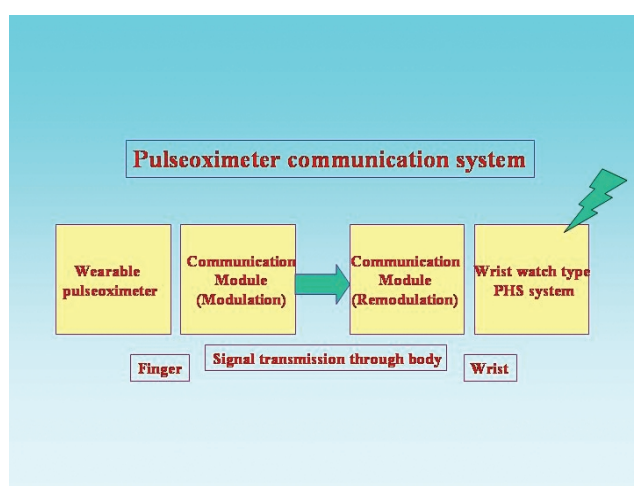
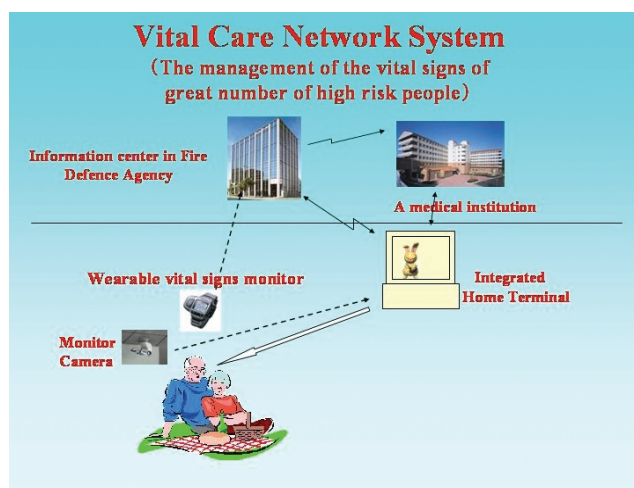

Research Grants

1. The Next Generation Software Project of Information-technology Promotion Agency, Japan. "Vital Care Network System". 2002. ¥128,000,000
2. JSPS Grants-in-aid for Scientific Research "The basic research of electrolyzed water for clinical use". 12470316 Basic Research (B)(2) 2000-2001. ¥6,200,000
3. JSPS Grants-in-aid for Scientific Research "Intravascular blood vessels detection using infrared for the aid of minimum invasive surgery". 13878179 Early Stage Research. 2001-2002. ¥1,300,000
4. Grants-in-aid for Innovative Project of Industry-University-Government Cooperation in Ministry of

Education, Culture, Sports, Science and Technology "The research for practical use of medical integral videography" 2000-2003. ¥130,000,000

5. Tokyo Metropolis Grants-in-aid for Industry-University-Government "Electrolyzed water for the bacterial wound healing" April 1999~Feb 2000. ¥6,569,000

Select Publications

1. Kitagawa H, Yamazaki T, Akiyama T, Yahagi N, Kawada T, Mori H, Sunagawa K: Modulatory effects of ketamine on catecholamine efflux from in vivo cardiac sympathetic nerve ending in cats. *Neurosci Lett* 24: 232-236; 2002
2. Kono M, Yahagi N, Kitahara M, Fujiwara Y, Sha M, Ohmura A: Cardiac arrest associated with use of an argon beam coagulator during laparoscopic cholecystectomy. *Br J Anaesth* 87: 644-646, 2001
3. Yahagi N, Kono M, Kitahara M, Fujiwara Y, Asakawa Y, Katagiri J, Sha M, Ohmura A, Murakami A, Takamoto S: Cause of airway obstruction during cuffed oropharyngeal airway. *Resuscitation* 48: 275-278, 2001
4. Yahagi N, Kono M, Kitahara M, Ohmura A, Sumita O, Hashimoto T, Hori K, Ning-Juan C, Woodson P, Kubota S, Murakami A, Takamoto S: Effect of electrolyzed waters on wound healing. *Artif Organs* 24: 984-987, 2000
5. Yahagi N, Matsui J, Matsui S, Amakata Y, Kumon K, Ueda-Ishibashi H. Low molecular weight dextran attenuates effects of oleic acid-induced lung injury in rats. *Am J Emerg Med* 18: 180-183, 2000
6. Yahagi N, Yamazaki T, Akiyama T: Either desipramine or TMB-8 suppresses cyanide on induced norepinephrine efflux from in vivo cardiac sympathetic nerves of cats. *Brain Research* 864: 157-161, 2000
7. Imanaka H, Nishimura M, Takeuchi M, Yahagi N, Kumon K: Autotriggering due to cardiogenic oscillation during flow-triggering mechanical ventilation. *Crit Care Med* 28: 402-407, 2000
8. Murakami A, Kaneko Y, Imanaka K, Takamoto S, Yahagi N: Easy aortic cannulation: a tranxyphoidal approach. *Artif Organs* 24: 156-157, 2000
9. Yahagi N, Shimizu R, Kono M, Kitahara M, Katagiri J, Sha M, Ohmura A: Retractor to facilitate fiberoptic-aided tracheal intubation. *Resuscitation* 41: 283-284, 1999
10. Kumon K, Yahagi N, Imanaka H, Takeuchi M, Miyano H, Ohashi Y. Nitric oxide inhalation as a chemical assist for the circulation in patients after cardiac surgery. *Artif Organs* 23: 169-174, 1999
11. Yahagi N, Tanigami H, Watanabe Y, Kumon K: Semiprone position relieved airway obstruction resulting from dilated pulmonary artery. *Ann Thorac Surg* 67: 894, 1999
12. Yahagi N, Kumon K, Tanigami H, Watanabe Y, Haruna M, Hayashi H, Takamoto S. Cardiac surgery

- and inhaled nitric oxide: Indication and follow up. *Artif Organs* 22: 886-891, 1998
13. Yahagi N, Kumon K, Watanabe Y, Tanigami H, Haruna M, Hayashi H, Imanaka H, Takeuchi M, Ohashi Y, Takamoto S: Value of mild hypothermia in patients who have severe circulatory insufficiency despite the use of IABP. *J Clin Anesth* 10: 120-125, 1998
 14. Yahagi N, Akiyama T, Yamazaki T: Effect of omega-conotoxin GVIA on cardiac sympathetic nerve endings. *J Auton Nerv System* 68: 43-48, 1998
 15. Yahagi N, Watanabe Y, Kumon K: Ultrasound detection of diaphragmatic paralysis after cardiac surgery. *Ann Thorac Surg* 65: 1841, 1998
 16. Yahagi N: Invited commentary for "A randomized, double-blind trial of inhaled nitric oxide in LVAD recipients with pulmonary hypertension". *Ann Thorac Surg* 65: 345, 1998
 17. Haruna M, Kumon K, Yahagi N, Watanabe Y: Blood volume measurement at bed side using ICG pulse spectrophotometry. *Anesthesiology* 89: 1322-1328, 1998
 18. Kumon K, Yahagi N: Nitric oxide inhalation increased oxygen delivery after cardiovascular surgery in adult patients whether or not they have pulmonary hypertension. *J. Anesth* 12: 180-184, 1998
 19. Yamazaki T, Akiyama T, Kawada T, Kitagawa H, Takauchi Y, Yahagi N, Sunagawa K: Norepinephrine efflux evoked by potassium chloride in cat sympathetic nerves: dual mechanism of action. *Brain Res* 794: 146-150, 1998
 20. Nakayama M, Kumon K, Yahagi N, Haruna M, Watanabe Y, Hayashi H: Antiphospholipid antibody syndrome in a case with redo coronary artery bypass grafting under cardiopulmonary bypass. *Surg Today* 28: 423-426, 1998
 21. Yahagi N, Kumon K, Tanigami H, Watanabe Y, Haruna M, Matsui J: Helium/Oxygen breathing improved hypoxemia after cardiac surgery. *Artif Organs* 21: 24-27, 1997
 22. Yahagi N, Kumon K, Watanabe Y, Tanigami H, Haruna M, Hayashi H, Imanaka H, Takeuchi M, Murakami A: Detection of tracheal stenosis by cineangiocardiology in patients with congenital heart disease. *Anesth Analg* 85: 1180-1181, 1997
 23. Matsui J, Yahagi N, Kumon K, Hayashi H, Watanabe Y, Haruna M, Yagihara T, Takamoto S: Effect of inhaled nitric oxide on postoperative pulmonary circulation in patients with congenital heart disease. *Artif Organs* 21: 17-20, 1997
 24. Tanigami H, Yahagi N, Kumon K, Watanabe Y, Haruna M, Matsui J, Hayashi H: Long-term sedation with isoflurane for patients after cardiac surgery. *Artif Organs* 21: 21-23, 1997
 25. Hayashi H, Kumon K, Yahagi N, Haruna M, Watanabe Y, Matsui J, Hattori R: Successful treatment of mediastinitis after cardiovascular surgery using electrolyzed strong acid aqueous solution. *Artif Organs* 21: 39-42, 1997
 26. Yamazaki T, Kawada T, Akiyama T, Kitagawa H, Takauchi Y, Yahagi N, Sunagawa K: Omega-conotoxin GVIA and desipramine insensitive norepinephrine efflux from cardiac sympathetic nerve terminal. *Brain Res* 761: 329-332, 1997
 27. Murakami A, Fukahara K, Ichida F, Yahagi N, Kumon K: Significance of nitric oxide inhalation for reperfused lung. *Artif Organs* 21: 83-84, 1997
 28. Watanabe Y, Kumon K, Yahagi N, Haruna M, Hayashi H, Matsui J: Use of a pulse dye-densitometry ICG-test (indocyanine green clearance test) to evaluate liver cirrhosis before cardiac surgery. Comparison with Child's classification. *World Congress Intensive Crit Care Med* 9: 94, 1997
 29. Watanabe Y, Kumon K, Yahagi N, Haruna M, Hayashi H, Matsui J: Assessment of hepatic function using a pulse dye-densitometry ICG-test (indocyanine green clearance test): value in patients with deteriorated liver function after cardiac surgery. *9th European Congress on Intensive Care Medicine* pp 797-801, 1996
 30. Yahagi N, Kumon K, Tanigami H, Watanabe Y, Matsui J: Helium/Oxygen breathing improved hypoxemia after cardiac surgery: Case reports. *Anesth Analg* 80: 1042-1045, 1995
 31. Yahagi N, Kumon K, Nakatani H, Matsui J, Sasako Y, Isobe F, Sakakibara Y, Kitoh Y, Nagata S, Haruna M, Watanabe Y, Takamoto S: Inhaled nitric oxide for the management of acute right ventricular failure in patients with a left ventricular assist system. *Artif Organs* 19: 557-558, 1995
 32. Yahagi N, Tanigami H, Watanabe Y, Kumon K: A problem with an infant speaking tracheotomy tube (Vocalaid"). *Anaesthesia* 50: 91-92, 1995
 33. Yahagi N, Kumon K, Umemoto T, Shimura H, Kawaguchi AT, Tanigami H, Miyashita K: Cyclic decrease in mixed venous oxygen saturation for the early diagnosis of seizure complications after cardiac surgery. *Anesth Analg* 80: 404-407, 1995
 34. Yahagi N, Kumon K, Tanigami H, Watanabe Y, Sato T: A new, simple device for fixing orotracheal tubes. *Anaesthesia* 49: 916, 1994
 35. Yahagi N, Kumon K, Tanigami H, Watanabe Y, Ishizaka T, Yamamoto F, Nishigaki K, Matsuki O, Yagihara T: Inhaled nitric oxide for the postoperative management of Fontan-type operation. *Ann Thorac Surg* 57: 1371-1372, 1994
 36. Yahagi N, Furuya H, Matsui J, Sai Y, Amakata Y, Kumon K: Improvement of the left Boncho-Cath" double lumen tube. *Anesthesiology* 81: 781-782, 1994
 37. Yahagi N, Kumon K, Nakatani T, Ishikawa T, Tanigami H, Eishi K, Takahashi S: Peripartum cardiomyopathy and tachycardia followed by multiple organ failure. *Anesth Analg* 79: 581-582, 1994
 38. Yahagi N, Tanigami H, Kumon K, Yamada K, Takahashi O, Yagihara T: Tracheal granulations secondary to wall compression by endotracheal tubes in infants. *Can J Anaesth* 41: 1123-1124, 1994

39. Yahagi N, Kumon K, Tanigami H: Bronchial lavage with a fiberoptic bronchoscope via a laryngeal mask airway in an infant. *Anaesthesia* 49: 450, 1994
40. Murakami A, Fukahara K, Uozaki Y, Ichida F, Tsubata S, Yagihara T, Yahagi N. Three cases of left ventricular outflow tract obstruction after intracardiac repair of congenital heart disease. *Advanced Cardio-Thoracic Surg*, Axel Springer Japan Publishing. pp11-4, 1994
41. Yahagi N, Kumon K, Sugimoto H, Inagaki Y: A use of telescope of rigid type bronchoscope through endotracheal tube in infants. *Anesth Analg* 76: 207, 1993
42. Kumon K, Sugimoto H, Kitahara H, Yahagi N: Application of recombinant human erythropoietin for preoperative autologous blood banking on patients undergoing cardiac surgery. *Therapeutic Plasmapheresis (XII)*, pp 875-878, 1993
43. Inagaki Y, Kumon K, Sugimoto H, Yahagi N: A new hemofiltration device with reversible roller pump for correcting volume controlled by a precise weight balancer. *Therapeutic Plasmapheresis (XII)*, pp 757-759, 1993
44. Yahagi N, Nishikawa A, Matsui S, Komoda Y, Sai Y, Amakata Y: Pituitary apoplexy following cholecystectomy. *Anaesthesia* 47: 234-236, 1992
45. Yahagi N, Nishikawa A, Sai Y, Matsui J, Amakata Y: Double aortic arch presenting as massive haematemesis after removal of a nasogastric tube. *Can J Anaesth* 39: 894, 1992
46. Yahagi N, Furuya H, Sai Y, Amakata Y: Effect of halothane, fentanyl, and ketamine on the threshold for transpulmonary passage of venous air emboli in dogs. *Anesth Analg* 75: 720-723, 1992
47. Stuhmar W, Conti F, Suzuki H, Wang X, Noda M, Yahagi N, Kubo H, Numa S: Structural parts involved in activation and inactivation of the sodium channel. *Nature* 339: 597-603, 1989
48. Suzuki h, Bechk S, Kayano T, Noda M, Kubo H, Yahagi N, Numa S: Functional expression of cloned cDNA encoding sodium channel III. *FEBS Letters* 228: 195-200, 1987
49. Yahagi N, Furuya H: The effects of halothane and pentobarbital on the threshold of transpulmonary passage of venous air emboli in dogs. *Anesthesiology* 67: 905-909, 1987
50. Yahagi N, Miyazaki M, Itoh Y: Cardiopulmonary effect of halothane concentration on pulmonary circulation during air embolism in dogs. *Resuscitation* 13: 81-86, 1986

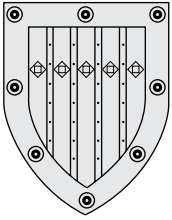

Department of Mental Health

Outline and Research Objectives

Outline

The department was first established as the 4th Department of Clinical Medicine and Nursing in the School of Health Care and Nursing in the Faculty of Medicine University of Tokyo in 1953. The department was renamed to the department of Mental Hygiene according to the reorganization of the School of Health Care and Nursing into the School of Health Sciences in 1965. In 1992, the department underwent second renaming to the Department of Mental Health and Psychiatric Nursing by the reorganization of the School of Health Sciences into the School of Health Sciences and Nursing. In 1997, according to the restructuring of the Faculty of Medicine into the Graduate School of Medicine, the Department of Mental Health and Psychiatric Nursing was divided into the Department of Mental Health and the Department of Psychiatric Nursing.

Research Objectives

The research objectives of this department are to conduct clinical psychosocial studies in the vast field of mental health and to disseminate results of those studies internationally.

For the last five decades, the department has had many clinical research projects, for example, psychotherapy, forensic psychiatry, community mental health, mental health/psychiatric services, psychiatric rehabilitation, child and adolescent mental health, and developmental disorders, depending on the specialty and interests of faculty members, who have conducted those studies in collaboration with researchers in and outside Japan by employing psychosocial methodologies adopted from diverse allied disciplines (i.e., psychiatry, clinical psychology, nursing, education and sociology).

For the past five years, this department has conducted clinical studies with close collaboration with the Department of Psychiatric Nursing established in 1997. The Department of Psychiatric Nursing has many clinical research projects of its own to substantiate clinical activities in psychiatric nursing; time and motion studies of nurses in acute psychiatric wards; clinical competency of psychiatric nursing; skills of community psychiatric nursing; mother's mental health and child abuse; issues of spirituality with cancer patients; and care burden of families with ALS clients.

For the last decade, the Department of Mental Health has concentrated its research activities mainly in 5 areas: (a) developmental disorders, (b) child and adolescent mental health, (c) mental health services, (d) geriatric psychiatry/mental health, and (e) social psychiatry/community mental health, as introduced in the past research and major accomplishment section.

Faculties and Students

Professor and Chair	Hiroshi Kurita, MD, PhD (since 1992)
Associate Professor in Mental Health	Iwao Oshima, PhD (since 1996)
Associate Professor in Psychiatric Nursing	Mami Kayama, PhD (since 2002)
Associate	1
Graduate student	37
Research student.....	8
Secretary	4

Past Research and Major Accomplishments

The major accomplishments of this department are summarized below in 5 areas, with the number of a related article listed in the select publications section in parentheses.

(a) Developmental disorders (1-16)

In this area, studies on Childhood disintegrative disorder (CDD) and related conditions (1, 5, 9) are particularly of note. CDD is an autistic condition of unknown etiology characterized by severe mental

regression emerged after normal mental development at least by age 2 followed by a severe autistic and mentally retarded state. Prof. Kurita, one of leading clinical researchers of CDD, has conducted diagnostic/nosological studies on CDD or its synonym, disintegrative psychosis (DP), in comparison with autism that could show similar yet much milder regression than CDD/DP. Those studies contributed to the adoption of CDD as a type of pervasive developmental disorders (PDD) in the two international diagnostic systems: the Diagnostic and Statistical Manual of Mental Disorders 4th edition (DSM-IV) (American Psychiatric Association, 1994) and the International Classification of Diseases and Related Health Problems 10th revision (ICD-10) (World Health Organization, 1993).

(b) Child and adolescent mental health (17-24)

We conducted studies aiming at clarifying the prevalence of behavior and emotional problems in Chinese children and their risk factors by using a Chinese version of the Child Behavior Checklist (CBCL) in collaboration with the Department of Psychiatry, Shandong Medical School, China. The studies participated by about 3,000 children and adolescents and their parents and teachers in Shandong province yielded a series of outstanding papers. The findings in those studies would contribute to the promotion of mental health of Chinese children and adolescents.

(c) Mental health services (25-34)

Studies in this area clarified present status and challenges of mental health services: service systems (26, 27, 30, 33); evaluation of services (28, 32, 34); and mental health problems in professionals (29, 31).

(d) Geriatric psychiatry/mental health (35-42)

Studies in this area clarified early neuropsychological deficits of patients with dementia (37, 38); pathophysiology of Alzheimer's disease (35, 40, 41); mental health problems of the elderly (39); and mental health of caregivers of patients with dementia (36, 42).

(e) Social psychiatry/community mental health (43-46)

This area involves studies on alcohol dependency (43), mental health problems of sexual harassment victims (44), and supporting patients with schizophrenia (45, 46).

Current Research

(a) Screening pervasive developmental disorders

Pervasive developmental disorders (PDD) are a

group of autistic conditions adopted in the current international classification systems of mental disorders, DSM-IV and ICD-10. The prevalence of PDD was recently reported as high as 0.6%.

The early detection of PDD is important, since early intervention is suggested as effective in ameliorating autistic symptoms and facilitating development of children with PDD even if the cure is not possible. For early detection of PDD, we developed a Japanese version of CHAT (Checklist for Autism in Toddlers), a promising screening tool for PDD developed in UK, and are now gathering clinical data. We also used the Tokyo Autistic Behavior Scale (TABS) developed by us and the Infant Behavior Checklist (IBC), both of which rate autistic behavior in infancy, in the same clinical fields as the CHAT data are gathered to collect data on early features of PDD. Based on these data, we are planning to develop an efficient screening system for PDD.

(b) Early development of high-functioning PDD

High-functioning PDD (HPDD) is a PDD with an IQ over 70 (i.e., not mentally retarded). Although such PDD was considered rare until late 1980s, more than 50% of PDD patients are now suggested to be HPDD. However, social and vocational outcomes of HPDD patients are quite unsatisfactory due to a lack of adequate programs for their education and social adaptation. It is quite unknown how HPDD differs from mentally retarded PDD in early developmental characteristics. Since such features would help early identification of HPDD among PDD, we are now gathering relevant data in young PDD children by using the TABS, IBC and other scales.

(c) Adult outcomes of PDD patients

PDD is a life-long condition but its adult outcomes are still unclear, since many of long-term outcome studies of PDD were conducted before 1990, when remedial education and social support systems were not well established. Since we have one of the largest data bases on PDD in the world and have followed-up a large number (more than 150) of adult PDD patients (over age 20). We are now conducting a comparative study of adult outcomes between autistic disorder (prototypical PDD) and other PDD. We are also planning a study to clarify prognostic factors of adult outcomes of PDD.

(d) Difference and similarity of high-functioning PDD and attention deficit/hyperactivity disorder (ADHD)

In clinical settings, it is frequently difficult to differentiate between high-functioning PDD (HPDD) and ADHD, though difference in treatment does exist between them. We are now conducting a comparative

study between HPDD and ADHD to identify clinical variables to differentiate between both conditions.

Future Prospects

The most important thing for the department in the foreseeable future is to facilitate research activities on mental health more intensively and extensively in collaboration with researchers in and outside Japan. Since the current professor will retire in 2 years from now and in view of the diversity and broadness of the field of mental health, it is difficult to prospect fixed research themes in the future. However, it is crucially important to have a world-class clinical researcher who can perform excellent studies on mental health in his/her own specialty and educate graduate students based on those research activities. Such a person would come from any specialty relating to mental health.

It is also important to facilitate psychiatric nursing studies in collaboration with the Department of Psychiatric Nursing established in 1997, which has published many quality Japanese papers based on its clinical studies and is now concentrating to publish English papers. Since many graduate students have participated in research projects in both departments, it is productive to continue the close collaboration of the two departments in clinical studies.

Research Grants (for the past 5 years)

1. The Research Grant (8B-3) for Nervous and Mental Disorders (the Ministry of Health and Welfare). Title: The study on pathophysiology and treatment of disorders of behavioral, emotional and psychological development from infancy to adolescence. Term: 1996-1998. Head investigator: Hiroshi Kurita, MD
2. Grant-in-Aid for Scientific Research (C) (2) (the Ministry of Education, Science, Sports and Culture). Title: A clinical study on symptoms, development and course of childhood disintegrative disorders. Term: 1997 to 2000. Head investigator: Hiroshi Kurita, MD
3. Grant-in-Aid (11A-6) for Research on Nervous and Mental Disorders (the Ministry of Health, Labour and Welfare). Title: A study on the relationship between attention-deficit/hyperactivity disorder and pervasive developmental disorders. Term: 1999-2001. Investigator: Hiroshi Kurita, MD
4. Grant-in-Aid for Scientific Research (C) (2) (the Ministry of Education, Culture, Sports, Science and Technology). Title: A nosological and diagnostic study on other pervasive developmental disorders. Term: 2001 to 2003. Head investigator: Hiroshi Kurita, MD
5. Grant-in-Aid (14A-8) for Research on Nervous and Mental Disorders (the Ministry of Health, Labour and Welfare). Title: A study on the difference and

similarity of attention-deficit/hyperactivity disorder and pervasive developmental disorders. Term: 2002-2004. Investigator: Hiroshi Kurita, MD

Select Publications

(a) Developmental disorders

1. Kurita H. Infantile autism with speech loss before the age of thirty months. *Journal of the American Academy of Child Psychiatry* 24, 191-196, 1985.
2. Kurita H, Uchiyama T and Takesada M. Tokyo Child Development Schedule. I. Test-retest reliability and concurrent validity. *Folia Psychiatrica et Neurologica Japonica* 39, 129-138, 1985.
3. Kurita H. Variables relating to the mental development of children with infantile autism. *Japanese Journal of Psychiatry and Neurology* 40, 161-168, 1986.
4. Kurita H. A case of Heller's syndrome with school refusal. *Journal of Autism and Developmental Disorders* 18, 315-319, 1988.
5. Kurita H. The concept and nosology of Heller's syndrome: Review of articles and report of two cases. *Japanese Journal of Psychiatry and Neurology* 42, 785-793, 1988.
6. Kurita H, Miyake Y and Katsuno K. Reliability and validity of the Childhood Autism Rating Scale—Tokyo Version (CARS-TV). *Journal of Autism and Developmental Disorders* 19, 389-396, 1989.
7. Kurita H and Miyake Y. The reliability and validity of the Tokyo Autistic Behavior Scale. *Japanese Journal of Psychiatry and Neurology* 44, 25-32, 1990.
8. Kurita H. School refusal in pervasive developmental disorders. *Journal of Autism and Developmental Disorders* 21, 1-15, 1991.
9. Kurita H, Kita M and Miyake Y. A comparative study of development and symptoms among disintegrative psychosis and infantile autism with and without speech loss. *Journal of Autism and Developmental Disorders* 22, 175-188, 1992.
10. Kurita H, Shiiya J and Ito H. A nationwide survey of day-care for children with mental retardation in Japan. *Japanese Journal of Psychiatry and Neurology* 48, 57-63, 1994.
11. Kurita H and Nakayasu N. An autistic male presenting seasonal affective disorder (SAD) and trichotillomania. *Journal of Autism and Developmental Disorders* 24, 687-692, 1994.
12. Kurita H, Saito T and Kita M. Regression in mental development following a psychosocial stressor in disintegrative psychosis. Shimizu M (Ed.). *Recent Progress in Child and Adolescent Psychiatry*, pp.21-28, Springer, 1996.
13. Kurita H. Specificity and developmental consequences of speech loss in children with pervasive developmental disorders. *Psychiatry and Clinical Neurosciences* 50, 181-184, 1996.

14. Kurita H. A comparative study of Asperger syndrome with high-functioning atypical autism. *Psychiatry and Clinical Neurosciences* 51, 67-70, 1997.
15. Kurita H. Delusional disorder in a male adolescent with high-functioning PDDNOS. *Journal of Autism and Developmental Disorders*, 29:419-423, 1999.
16. Tachimori H, Osada H, Kurita H. Childhood Autism Rating Scale--Tokyo version (CARS-TV) for screening pervasive developmental disorders (PDD). *Psychiatry and Clinical Neurosciences* (in press).
27. Ito H, Kishi Y and Kurosawa H. A preliminary study of staff perception of psychiatric services in general hospitals. *General Hospital Psychiatry* 21, 57-61, 1999.
28. Ito H, Shingai N, Yamazumi S, Sawa Y and Iwasaki S. Characteristics of nonresponders to a patient satisfaction survey at discharge from psychiatric hospitals. *Psychiatric Services* 50, 410-412, 1999.
29. Ito H, Kurita H and Shiya J. Burnout among direct-care staff members of facilities for persons with mental retardation in Japan. *Mental Retardation* 37, 477-481, 1999.

(b) Child and adolescent mental health

17. Liu XC, Ma DD, Kurita H and Tang MQ. Self-reported depressive symptoms among Chinese adolescents. *Social Psychiatry and Psychiatric Epidemiology* 34, 44-47, 1999.
18. Mori M. The influence of father-daughter relationship and girl's sex-roles on girl's self-esteem. *Archives of Women's Mental Health* 2, 45-47, 1999.
19. Liu XC, Kurita H, Guo CQ, Miyake Y, Ze J and Cao HL. Prevalence and risk factors of behavioral and emotional problems among Chinese children aged 6-11. *Journal of the American Academy of Child and Adolescent Psychiatry* 38, 708-715, 1999.
20. Liu XC, Kurita H, Sun ZX and Wang FX. Risk factors of psychopathology among Chinese children. *Psychiatry and Clinical Neurosciences* 53, 497-503, 1999.
21. Liu XC, Uchiyama M, Okawa M and Kurita H. Prevalence and correlates of self-reported sleep problems among Chinese adolescents. *Sleep* 23, 27-34, 2000.
22. Liu XC, Kurita H, Guo CQ, Tachimori H, Ze J and Okawa M. Behavioral and emotional problems in Chinese children: Teacher reports for ages 6 to 11. *Journal of Child Psychology and Psychiatry* 41, 253-260, 2000.
23. Liu XC, Guo CQ, Okawa M, Zhai J, Li Y, Uchiyama M, Neiderhiser JM and Kurita H. Behavioral and emotional problems in Chinese children of divorced parents. *Journal of the American Academy of Child and Adolescent Psychiatry* 39, 896-903, 2000.
24. Liu XC, Kurita H, Uchiyama M, Okawa M, Liu LQ and Ma DD. Life events, locus of control, and behavioral problems among Chinese adolescents. *Journal of Clinical Psychology* 56, 1565-1577, 2000.
30. Ito H, Eisen SV, Sederer LI and Tachimori H. Involuntary admission in Japanese psychiatric hospitals. *International Medical Journal* 7, 109-112, 2000.
31. Ito H, Eisen SV, Sederer LI, Yamada O and Tachimori H. Factors affecting psychiatric nurses' intention to leave their current job. *Psychiatric Services* 52, 232-234, 2001.
32. Ito H, Tachimori H, Miyamoto Y and Morimura Y. Are the care levels of people with dementia correctly assessed for eligibility of the Japanese long-term care insurance? *International Journal of Geriatric Psychiatry* 16, 1078-1084, 2001.
33. Ito H, Eisen SV and Sederer LI. Acute care psychiatry at McLean Hospital, Massachusetts. *International Medical Journal* 8, 91-96, 2001.
34. Ito H and Sederer LI. Are publicly-insured psychiatric outpatients in Japan satisfied? *Health Policy* 56, 205-213, 2001.

(e) Geriatric psychiatry/mental health

25. Kumakura N, Ito H, Mori T, Saito T, Kurisu E, Asaka A, Sasaki Y, Rhi B, Kim Y, Ha K, Rin H and Yang LY. Attitudes change towards mental illness during nursing education: A cross-cultural study of student nurses in Korea, Republic of China and Japan. *Asia-Pacific Journal of Public Health* 6, 120-125, 1992/1993.
26. Ito H, Mori T, Kumagai N, Miyauchi M, Harada S, Yamamura M, Nakano R, Kurita H and Sasaki Y. Changing pattern of mental health utilization in the Hachiojima. *Psychiatry and Clinical Neurosciences* 49, 185-187, 1995.
35. Dai XY, Nanko S, Hattori M, Fukuda R, Nagata K, Isse K, Ueki A and Kazamatsuri H. Association of apolipoprotein E4 with sporadic Alzheimer's disease is more pronounced in early onset type. *Neuroscience Letters* 175, 74-76, 1994.
36. Matsuda O. The effect of coping on the caregiver of elderly patients with dementia. *Psychiatry and Clinical Neurosciences* 49, 209-212, 1995.
37. Matsuda O, Saito M and Sugishita M. Cognitive deficits of mild dementia: A comparison between dementia of the Alzheimer's type and vascular dementia. *Psychiatry and Clinical Neurosciences* 52, 87-91, 1998.
38. Matsuda O and Saito M. Features of Alzheimer's disease: Crystallized and fluid intelligence in elderly patients with mild dementia of the Alzheimer type. *International Psychogeriatrics* 10, 147-154, 1998.
39. Hashimoto K, Kurita H, Hratani T, Fujii K and Ishibashi T. Direct and buffering effects of social support on depressive symptoms of the elderly with home help. *Psychiatry and Clinical Neurosciences* 53, 95-100, 1999.
40. Asada T, Motonaga T, Yamagata Z, Uno M and Takahashi K. Association between retrospectively recalled napping behavior and later development of Alzheimer's disease: Association with APOE genotypes. *Sleep* 23, 629-634, 2000.

41. Asada T, Motonaga T and Kinoshita T. Predictors of severity of behavioral disturbance among community-dwelling elderly individuals with Alzheimer's disease: A 6-year follow-up study. *Psychiatry and Clinical Neurosciences* 54, 673-677, 2000.
42. Miyamoto Y, Ito H, Otsuka T, Kurita H. Caregiver burden in mobile and non-mobile demented patients: A comparative study. *International Journal of Geriatric Psychiatry* 17, 765-773, 2002.

(d) Social psychiatry/community mental health

43. Matsuoka K, Kim Y, Toshida S and Oshima N. Relationship between age of onset, antisocial history and general psychopathological traits in Japanese alcoholics. *Psychiatry and Clinical Neurosciences* 54, 413-417, 2000.
44. Matsuoka K, Kurita H, Abe R and Osada H. Mental health of sexual harassment victims in Japanese nurses. *Archives of Women's Mental Health* 4, 1-4, 2001.
45. Kayama M, Zerwech J, Thornton K and Murashima S. Japanese expert public health nurses empower clients with schizophrenia living in the community. *Journal of Psychosocial Nursing and Mental Health Services* 39, 40-45, 2001.
46. Oshima I, Ito J, Taira N. Need for an integrated program of case management and psychoeducation in long stay psychiatric patients in Japan. Kashima H, Falloon IRH, Mizuno M and Asai M. (eds). *Comprehensive Treatment of Schizophrenia: Linking neurobehavioral findings to psychosocial approaches*. Springer, Tokyo, pp.196-203, 2002.

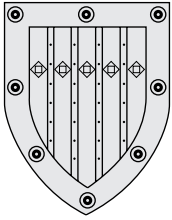

Department Of Social Gerontology

Outline And Research Objectives

It is often voiced from the general public that recent advancement of medicinal technology would not necessarily lead to the happiness of people: Life prolongation technology enables even the terminally ill to live for a considerable period. How to use the technology is a serious problem in clinical practice. Also, there is evidence that the prolongation of life expectancy for the elderly does not mean the prolongation of health and productivity, but that of morbidity.

Taking another example, we are experiencing ethical dilemmas with the application of medical technology such as genetic screenings and organ transplantation. When we turn to the worldwide situation regarding health, we will find poverty and unequal distribution in terms of health resources and outcomes.

The department is studying these health-related problems from psycho-social-ethical perspectives, many of which are often difficult to decide upon. Major topics include elderly health, cancer and/or terminal care, international health and bio-medical ethics among others. We are currently conducting several research projects as described below.

Faculties and Students

Professor and Chair	Ichiro Kai, M.D., M.P.H. (since 1997)
Associate Professor and Lecturer	None
Associate	2
Visiting Researcher	22
Graduate student	18
Research student.....	3

Past Research And Major Accomplishments

1. Elderly Health

This is the major field of interest of our department. Several most important researches will be briefly described.

1) Psychotic manifestations of the demented elderly and their relationship with caretakers

We examined the correlation between the psychotic symptoms of the demented elderly and their relationship with caretakers. We developed a scale measuring the relationship (CPR Scale), and conducted survey in three culturally different areas, Tokyo, Nagano and Okinawa. We found the better relationship indicated by higher CPR score led to less psychotic symptoms. The results suggest that the psychotic manifestations of dementia can be influenced by environmental factors. (References 2-5, 12,17)

2) Functional capacity and active life expectancy (ALE) of the elderly

The health status of a population is traditionally measured by mortality. However, indices based on mortality are increasingly unsatisfactory to assess health status, especially in an aging society. We conducted survey on functional capacity of the elderly and its chronological changes, using a large-scale cohort of the community residents in Nagano Prefecture. We calculated active life expectancy (ALE) and suggested it could be a useful health indicator for elderly population. (References 16,18, 37-38, 46)

3) Reciprocity of social support on subjective well-being of the elderly

Traditional support study emphasizes the importance of receiving support. We examined the pattern of support exchange (i.e., receiving and providing) and its effects on the subjective well-being of the elderly in rural Japan as well as a number of Asian countries such as Korea, Malaysia and Indonesia. In Korea, both receiving and providing support correlated to better subjective well-being, while only providing did in Japan. We concluded the meaning of receiving support were different between the two cultures. The findings led to further intervention study, as described later in this document. (References 23, 41-42)

4) Long-term care of the elderly

Long-term care of the elderly becomes increasingly important medical/welfare issue in Japan. Geriatric intermediate care facilities (GICFs) were established in 1986 to facilitate discharge from hospitals and sup-

port home care. Since then, we have conducted surveys on how the GICFs were used in Japan, and proposed the policy for their effective utilization. (References 20, 22, 39)

2. Cancer Care and Terminal Care

We conducted several surveys on cancer/terminal care with special emphasis on psycho-social and quality of life (QOL) aspects. We emphasize the importance of effective communication between patients and health care providers. Recently, we are interested in socio-cultural aspects of sexuality after cancer therapy. The latter is partly supported by Grant-in-Aid for Scientific Research from Japanese Society for Promotion of Science (JSPS). (References 14, 19, 24, 34, 36, 40)

3. International Health

The majority of the studies regarding international health were done while I was affiliated with Department of International Community Health, School of International Health, from 1992 to 1997. We were particularly interested the prevention of AIDS in Japan and the other countries in Asia. (References 10-11, 13, 15, 25, 28-29)

4. Bio-medical Ethics

The majority of the studies regarding bio-medical ethics were done in collaboration with Prof. Akira Akabayashi, who was a lecturer of our department and is now the chair of Department of Health Economics. Most studies are questionnaire surveys, and the topics include the ethics education in medical schools and the role of ethics committees among others. (References 21, 26-27, 31, 33, 35, 43-44)

Current Research

Two of the ongoing research projects of the department will be described below.

1. Intervention Study on Social Support Exchange

Our previous study suggests that providing support to spouse, children and friends is important to promote the subjective well-being of the elderly. We devised an intergenerational program involving the elderly and college students. The intervention was basically an interview in which the elderly were supposed to help the college students by telling their life history to the students and, in turn, were benefited by the interview. We found the majority of outcome indices such as life satisfaction and the attitudes toward young generation had improved considerably after the intervention. This study was partly supported by Grant-in-Aid for Scientific Research from JSPS.

2. Frequency of Going Outside and Risk of Functional Decline among the Frail Elderly

To be house-bound is hypothesized to heighten the risk of functional and intellectual deterioration among the frail elderly. We followed up a cohort of the frail elderly in Nagano Prefecture, and examined the relationship between the frequency of going outside home and various physical and psychological outcomes indices. Even after controlling a number of confounding factors, going outside home was shown to inversely correlate to deterioration in physical and psychological health one-year later. These findings suggest the importance of preventing house-bound status of the frail elderly. Subsequently, we are conducting an intervention study involving home visiting by public health nurses. This study is partly supported by Grant-in-Aid for Longevity Study from Ministry of Health, Labor and Welfare and Mitsubishi Foundation.

Future Prospects

Two of the possibly important research fields for our department will be briefly mentioned below.

1. Study on Successful Aging and Productivity

Successful aging is an important concept in the field of contemporary gerontology. One of the key factors to enable successful aging is productivity. We plan to conduct survey on productivity including salaried work, household work and volunteer, and its relationship with the health of the elderly. Large-scale intervention study on prosocial behaviors by the elderly (e.g., providing support to others) will be done as well.

2. Effective Policy for Long-term Care

Since the establishment of Long-term Care Insurance (LCI) in 2000, care of the frail elderly has become important social issue. In future, we plan to put more emphasis on practical aspects and policy issues in social gerontology. We plan to conduct a large-scale survey on LCI users in Tokyo Metropolitan Area and make recommendations on the policy for effective long-term care in Japan.

Research Grants

1. Intervention study on social support exchange: An intergenerational program involving the elderly and high school students. Grant-in-Aid for Scientific Research (KAKENHI) from JSPS (three years from 1998 to 2001) 2.8 million yen
2. Change and its related factors in sexuality for patients experiencing breast cancer surgery. Grant-

in-Aid for Scientific Research (KAKENHI) from JSPS (three year from 2000 to 2003) 3 million yen

3. Frequency of going outside home and functional decline among the frail elderly. Grant-in-Aid for Longevity Study (KAKENHI) from Ministry of Health, Labor and Welfare (three years from 2000 to 2003) 5.35 million yen
4. Effectiveness of a home visiting program for the house-bound elderly. Mitsubishi Foundation (two years from 2001 to 2003) 2 million yen
5. Predictors for frailty and/or mortality among the rural elderly. Daiwa Health Foundation (one year from 2001 to 2002) 1 million yen

Select Publications

(1) Original Articles

1. Kai I, Inaba Y: Statistical analysis on large-scale food poisoning outbreaks of unknown etiology. *Food Hygiene Study* 29(12):1031-1040, 1979 (in Japanese)
2. Ohi G, Miyama T, Kai I, et al.: Psychotic manifestations in the bedfast elderly: The role of intellectual impairment and environmental stress. *Jap. J. Gerontology* 6(2):124-138, 1984 (in Japanese)
3. Kai I, Ohi G, Suzuki S: Applicability of Hasegawa's Dementia Rating Scale in rural areas in Japan: Comparative study in Tokyo and Okinawa. *Gerontological Psychiatry* 2(2):293-298, 1985 (in Japanese)
4. Ichikawa S, Nakagawa M, Ohi G, et al.: Development of caretaker-patient relationship assessment scale for the frail elderly. *Jap. J. Public Health* 32(5):253-257, 1985 (in Japanese)
5. Miyama T, Suzuki S, Ohi G, et al.: Psychotic manifestations in the elderly with intellectual impairment: Influence of the degree of their intellectual deterioration and caretaker-patient relationship. *Jap. J. Public Health* 32(7):325-332, 1985 (in Japanese)
6. Nagahashi M, Yamazaki N, Ohi G, et al.: Dietary fiber intake and diverticular disease of the colon: A case control study. *Jap. J. Hygiene* 40(4):781-788, 1985 (in Japanese)
7. Takenaga N, Kai I, Ohi G: Evaluation of three cervical cancer detection programs in Japan with special reference to cost-benefit analysis. *Cancer* 55(10):2514-2519, 1985
8. Yamaoka K, Ohi G, Miyama T, et al.: Burden of caretakers of the bedridden elderly: Development of a unidimensional scale. *Jap. J. Public Health* 33(6):279-284, 1986 (in Japanese)
9. Ohi G, Hasegawa T, Kumano H, et al.: Why are cadaveric renal transplants so hard to find in Japan?: An analysis of economic and attitudinal aspects. *Health Policy* 6:269-278, 1986
10. Ohi G, Kai I, Kobayashi Y, et al.: Epidemic potential of AIDS and health policy in Japan. *Jap. J. Public Health* 34(2):49-54, 1987 (in Japanese)
11. Kai I, Ohi G: Infectious disease specialists in academe and AIDS epidemics: Comparison of specialists in public health and clinical medicine. *Jap. J. Public Health* 34(4):195-198, 1987 (in Japanese)
12. Takenaga N, Kai I, Ohi G, et al.: The caretaker-patient relationship and psychotic manifestations in the bedridden elderly. *Jap. J. Hygiene* 42(2):563-569, 1987 (in Japanese)
13. Ohi G, Kai I, Kobayashi Y, et al.: AIDS prevention in Japan and its cost-benefit aspects. *Health Policy* 8:17-27, 1987
14. Kobayashi Y, Yamaoka K, Ohi G, et al.: The economic analysis of home and hospital care for terminally ill patients. *Jap. J. Public Health* 35(1):11-18, 1988 (in Japanese)
15. Ohi G, Terao H, Hasegawa T, et al.: Notification of HIV carriers: Possible effect on uptake of AIDS testing. *Lancet* II:947-949, 1988
16. Kobayashi Y, Kai I, Ohi G, et al.: A study on instrumental activities of daily living and its related factors in the elderly in the farming community. *Jap. J. Public Health* 36(4):243-249, 1989 (in Japanese)
17. Ohi G, Kai I, Ichikawa S, et al.: Psychotic manifestations in the bed-fast elderly: A preliminary communication. *J. Human Ergology* 18:237-240, 1989
18. Kai I, Ohi G, Kobayashi Y, et al.: Quality of life: A possible health index for the elderly. *Asia-Pacific J. Public Health* 5(3):221-227, 1991
19. Kai I, Ohi G, Yano E, et al.: Communication between patients and physicians about terminal care: A survey in Japan. *Soc. Sci. & Med.* 36(9):1151-1159, 1993
20. Ishizaki T, Kai I, Hirayama T: Factors influencing users' destination upon discharge from a geriatric intermediate care facility in an urban area. *Jap. J. Geriatrics* 32(2):105-110, 1995 (in Japanese)
21. Nishimura T, Miyasaka M, Akabayashi A, et al.: The development of evaluation method for bioethics education in Japan: A questionnaire for measuring the ethical problem identification ability. *Bioethics* 5(1):73-77, 1995 (in Japanese)
22. Ishizaki T, Kai I, Hisata M, et al.: Factors influencing users' return home on discharge from a geriatric intermediate care facility in Japan. *J. Am. Geriatric Soc.* 43(6):623-626, 1995
23. Kim HK, Lee SK, Hisata M, et al.: Social support exchange and quality of life among the Korean elderly in a rural area. *Jap. J. Public Health* 43(1):37-49, 1996 (in Japanese)
24. Hisata M, Okazaki N, Kai I, et al.: Attitudes of outpatients toward informed consent in cancer treatment. *J. Jap. Soc. Cancer Therapy* 31(3):171-185, 1996 (in Japanese)
25. Ohi G, Uemura I, Akabayashi A, et al.: Preventive behaviors against HIV transmission adopted by Japanese commercial sex workers (CSWs). *Environ. Health & Prev. Med.* 2(3):132-134, 1997
26. Akabayashi A, Kai I, Itoh K, et al.: The acceptability of advance directive in Japanese society: A questionnaire study for healthy people in the physical check-up settings. *Bioethics* 7(1):31-40, 1997 (in Japanese)
27. Fukatsu N, Akabayashi A, Kai I: The current status of ethics committees and decision making proce-

- dures in general hospitals in Japan. *Bioethics* 7(1):130-136, 1997 (in Japanese)
28. Nishimura-Takahashi T, Akabayashi A, Kai I, et al.: Social and behavioral factors associated with condom use among female commercial sex workers (CSWs) in Tarlac, the Philippines. *Environ. Health & Prev. Med.* 2(4):167-171, 1998
 29. Takai A, Wongkhomthong S, Akabayashi A, et al.: Correlation between history of contact with people living with HIV/AIDS (PWAs) and tolerant attitudes toward HIV/AIDS and PWAs in rural Thailand. *International J. STD & AIDS* 9(8):482-484, 1998
 30. Honda T, Kai I, Ohi G: Fat and dietary fiber intake and colon cancer mortality: A chronological comparison between Japan and the US. *Nutr. & Cancer* 33(1):95-99, 1999
 31. Akabayashi A, Miyasaka M, Kai I, et al.: Survey of medical ethics education in Japanese medical schools. *Med. Education* 30(1):47-53, 1999 (in Japanese)
 32. Yokokawa Y, Kai I, Nakajima T: Development of a "Self Efficacy for Health Promotion Scale" in community-dwelling elderly. *Jap. J. Public Health* 46(2):103-112, 1999 (in Japanese)
 33. Akabayashi A, Kai I: Study of 5th-year medical students interest in medical ethics and related factors. *Med. Education* 30(2):77-82, 1999 (in Japanese)
 34. Akabayashi A, Kai I, Takemura H, et al.: Truth telling in the case of a pessimistic diagnosis in Japan. *Lancet* 354(9186):1263, 1999
 35. Miyasaka M, Akabayashi A, Kai I, et al.: Teaching medical ethics: An international survey of medical ethics curricula in Asia. *J. Med. Ethics* 25(6):514-521, 1999
 36. Takahashi M, Kai I, Akabayashi A, et al.: Who should meet the needs of breast cancer patients?: A questionnaire survey of Japanese surgeons. *Jap. J. Breast Cancer* 14(4):495-502, 1999 (in Japanese)
 37. Ishizaki T, Kai I, Kobayashi Y: Estimation of active life expectancy by Katz method: The results from Saku Cohort Study. *Health Indices* 46(4):23-27, 1999 (in Japanese)
 38. Ishizaki T, Kobayashi Y, Kai I: Functional transition in instrumental activities of daily living among older Japanese. *J. Epidemiol.* 10(4):249-254, 2000
 39. Ishizaki T, Kai I: Risk of acute hospitalization among long-term care patients. *Jap. J. Geriatrics* 37(6):472-478, 2000 (in Japanese)
 40. Watanabe Y, Akabayashi A, Ikeda T, et al.: An analysis of CPR decision-making by middle-aged and elderly healthy people in Japan. *Bioethics* 10(1):111-119, 2000 (in Japanese)
 41. Kim HK, Kai I, Hisata M, et al.: Social support exchange and subjective well-being among the Japanese elderly in a rural area. *Jap. J. Gerontology* 22(3):395-403, 2000 (in Japanese)
 42. Kim HK, Hisata M, Kai I, et al.: Social support exchange and quality of life among the Korean elderly. *J. Cross-Cultural Gerontology* 15(4):331-347, 2000
 43. Watanabe Y, Kai I, Akabayashi A: Attitude of general public toward genetic testing for colon cancer. *Bioethics* 12:32-40, 2001 (in Japanese)
 44. Akizuki Y, Kai I, Akabayashi A: Attitudes of the general public toward artificial insemination by donor. *Bioethics* 12:62-70, 2001 (in Japanese)
 45. Ohta M, Kai I: The development of a filial responsibility scale. *Jap. J. Social Welfare* 42(2):130-7, 2002 (in Japanese)
 46. Ishizaki T, Kai I, Kobayashi Y, et al.: Functional transitions and active life expectancy for older Japanese living in a community. *Arch. Gerontology & Geriatrics* 35(2):107-119, 2002
- (2) Other Papers (Books And Proceedings In English)**
47. Ohi G, Kai I, Terao H, et al.: Cost-benefit aspects of AIDS prevention programs: Its limitation in policy making. *in Fleming AF, et al. (eds.): The Global Impact of AIDS*, Alan R. Liss, Inc. (New York), pp.251-262, 1988
 48. Ohi G, Hisata M, Kai I: High-rise living and the elderly. *in Takano T (ed.): Urban Health*, Kyoiku Syoseki (Tokyo), pp.7-13, 1993
 49. Ishizaki T, Kai I, Hisata M, et al.: Factors influencing users' destination upon discharge from a geriatric intermediate care facility. *in Beregi E, et al. (eds.): Recent Advances in Aging Science*, Monduzzi Editore (Bologna), pp.2193-2196, 1993
 50. Kai I.: Active life expectancy and its correlates among the elderly living in a rural community in Japan. *in Hisamichi S, et al. (eds.): WHO-CC Monograph No.3 Active (Disability-Free) Life Expectancy*, WHO-Collaborating Center for Well-being in Aging (Sendai), pp.52-53, 1995

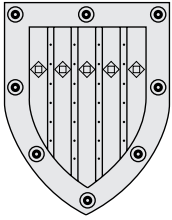

Department of Health Economics / Health Promotion Sciences / Biomedical Ethics

Outline and Research Objectives

The former Department of Health Administration was established in 1967 and Dr. Tsuneo Tanaka became its first professor in 1974. He devoted himself to the development of the community health care system in Japan and publishes numerous papers concerning the social theory of health administration and the data management systems for community health care. He also contributed to the establishment of the School of Health Sciences. In 1985, Dr. Atsuaki Gunji became the second professor of the department. During Dr. Gunji's tenure, two major research projects were undertaken. One was "the effects of physical activity and inactivity on health." From 1990, a 20-day bed rest human experimental study was conducted in the context of an international cooperative research project that was supported by government grants. The other project concerned health care systems, especially health care economics and the quality of hospital care.

In 1996, the Department of Health Administration was divided into two departments: the Department of Health Economics and the Department of Health Promotion Sciences. Both were established as departments of the Graduate School of Medicine. In 1998, Dr. Yasuki Kobayashi became professor of the Department of Health Economics. He conducted research into health care delivery systems in Japan. In 2001, he moved to the Department of Public Health. Since 1996, Dr. Kiyoshi Kawakubo has been taking charge of the Department of Health Promotion Sciences.

In June 2002, Dr. Akira Akabayashi (now concurrently at Kyoto University) was appointed as Dr. Kobayashi's successor. Dr. Akabayashi's research area is in biomedical ethics and a new Department of Biomedical Ethics will be officially established in April 2003.

Faculties and Students

Professor and Chair	Akira Akabayashi, M.D., Dr. Med. Sc., (2002~, concurrently at Kyoto University)
Associate Professors	Kiyoshi Kawakubo, M.D., Dr. Med. Sc., (1996~)
Associates	1
Postdoctoral Fellows	none
Graduate Students	7
Research Students.....	2
Secretaries	3

Past Research and Major Accomplishments

Past research can be divided into two fields, health economics and health promotion sciences. In the field of health economics, analysis of terminal care cost for the aged in a community, analysis of regional differences in medical care costs for the aged and analysis of hospital care costs and revenues were the main research topics. About 70% of the regional differences

was accounted for by the overall quantity of medical care supplies such as the number of hospital beds. Other topics were related to the economic aspects of health care and the quality of care. Both supply and demand analyses were performed on, for example, hospital costs and patient behavior. Tools for evaluating the quality of hospital care were also developed. Recent research topics include studies related to either or both the supply and demand sides of health care in Japan such as physician distribution, outcomes of the separation of pharmaceutical dispensing from medical practice, and patient behavior under Japan's national health insurance system. The main research questions are related to how the health and social systems shape the health care systems and health itself, and what system should be established in order to maintain both efficiency and equity.

The focus of research activities of the Department of Health Promotion Sciences is on the scientific basis of health promotion, specifically the effects of physical activity and inactivity on health status. Since 1991, a bed rest study has been performed, involving the

investigation of the effects of simulated microgravity on cardiovascular and metabolic parameters as well as on bone density. This is the first bed rest study conducted in Japan. The "Healthy Japan 21" strategy was introduced in 2000 by the former Ministry of Health and Welfare, and the department has devoted part of its "physical activity and exercise" studies to this strategy. Currently the department is engaged in the development of health promotion strategies for the community and workplace. The assessment of health promotion resources in the community and workplace is the major concern of these research activities.

Current Research

With the establishment of the new department of Biomedical Ethics in April 2003, the foci of the research projects may shift to healthcare ethics and health promotion sciences (behavioral science). Research in the field of health economics will also be performed in close relationship with the Department of Public Health (chaired by Dr. Y. Kobayashi). The research projects being conducted mainly by Dr. Akabayashi are described below.

Grant-supported research projects (within 5 years)

1. **Study of the methods for the formation of social consensus related to advanced medical technology.** The purposes of this project are: 1) to clarify ethical, legal, and social issues related to the implementation of new medical technology, and 2) to explore methods for the formation of social consensus and policy. This project includes the theoretical aspects of social consensus, historical case analysis of organ transplantation and gene therapy in Japan, and three nationwide surveys. Supported by the *Special Coordination Fund for Promoting Science and Technology, The Ministry of Education, Culture, Sports, Science and Technology*.
2. **Publication of a medical ethics case book for Japan.** The purpose of this project is to collect illustrative cases of ethical issues and to produce a casebook for the field of medical ethics in Japan, which is hoped to become a standard textbook for those who study or teach medical ethics as well as a resource for research. The book is also expected to help explain current Japanese medical ethics to interested persons in other countries. Supported by a *Grant-in-Aid for Scientific Research (B), The Ministry of Education, Science, Sports and Culture*.
3. **Study of the functions and responsibilities of ethics committees in Japan.** The growing number of ethics committees (ECs) indicates that signifi-

cant changes have occurred in the decision making process in the clinical setting in Japan. The main purposes of this study are: 1) to investigate the current status; 2) to make guidelines for establishing and running an EC in a general hospital setting; 3) to explore the extent of discretion and responsibility of ECs, and 4) to make a comprehensive proposal. Supported by a *Grant-in-Aid for Scientific Research (C), The Ministry of Education, Science, Sports and Culture*.

4. **Comparative study of clinical ethics in the Asian region.** The purpose of this project is to engender ongoing inter and intra regional dialogue, research, education and development of clinical ethics throughout the Asian region. Specifically, this project will focus on issues that stem from the nature of the clinician-patient relationship, such as how information is shared (informed consent, delivering bad news, role of the family, etc.), competence or decision-making capacity, confidentiality, and end-of-life decision making. The results obtained through this preliminary study will be used as the basis for a comprehensive study. Supported by a *Grant-in-Aid for Scientific Research (C), The Ministry of Education, Science, Sports and Culture*.
5. **Others:** Other research activities include research into the acceptability of advance directives in Japan (a grant from the Ministry of Education in 1996-1997), the development of evaluation methods for biomedical ethics education (a grant from the Ministry of Education in 1995-1996), and the ethical and psycho-social aspects of living related liver transplantation.

Future Prospects

Modern biomedical ethics in Japan has emerged as a new medical field and many medical schools are establishing relevant departments or units. As long as this discipline remains in the medical arena, it needs to deal with both theoretical and practical issues. Even though this discipline has not been fully established yet, many issues have already arisen. It is clear that the focus will have to be on the development of basic teaching and research methods that can garner the support of both the medical community and society in general. Ethics committees constitute an inescapable part of the activities related to this discipline. Without sound ethics committees, no research involving human subjects can be implemented. Within this departments unit, health economics and behavioral science make a major contribution to the study of biomedical ethics because allocation of health care resource is a major topic in healthcare ethics, and behavioral science is essential for the teaching of com-

munication skills with patients and an understanding of patient behavior. In the near future, this departments unit is hoped to become a domestic as well as an Asian regional center for academic research.

Research Grants (within 5 years)

1. *Study of the methods for the formation of social consensus related to advanced medical technology. Special Coordination Fund for Promoting Science and Technology, The Ministry of Education, Culture, Sports, Science and Technology 2001-2002, ¥55,000,000 (PI: Akabayashi, A)*
2. *Study on the health promotion environmental indices for the community: The Ministry of Health, Labor and Welfare, Health Sciences Research Grant, 2000-2001, ¥55,000,000 (PI: Kawakubo, K)*
3. *Publication of a medical ethics case book for Japan. Grant-in-Aid for Scientific Research (B), 1998-2000, The Ministry of Education, Science, Sports and Culture, ¥3,600,000 (PI: Akabayashi, A)*
4. *Comparative study of clinical ethics in the Asian region. Grant-in-Aid for Scientific Research (C), 2000, The Ministry of Education, Science, Sports and Culture, ¥1,200,000 (PI: Akabayashi, A)*
5. *Study of the functions and responsibilities of ethics committees in Japan. Grant-in-Aid for Scientific Research (C), 1997-1999, The Ministry of Education, Science, Sports and Culture, ¥2,200,000 (PI: Akabayashi, A)*

Select Publications

1. Akabayashi A. Euthanasia, assisted suicide, and cessation of life support: Japan's policy, law, and an analysis of whistle blowing in two recent mercy killing cases. *Social Science & Medicine* 55: 517-527, 2002.
2. Akabayashi A, Nishimori M, Fujita M, Slingsby BT. Living related liver transplantation: a Japanese experience and development of a checklist for donor's informed consent. *Gut* 51: 2002 (in press)
3. Akabayashi A, Slingsby BT, Voltz R. Advance Directives. In Bruera E. eds., *Palliative Care in Neurology* Oxford University Press, New York, NY, 2002 (in press).
4. Matsushima T, Akabayashi A, Nishitaten K. The current status of bereavement follow-up in hospice and palliative care in Japan. *Palliative Medicine* 16: 151-158, 2002.
5. Akabayashi A. "To Intervene?", "Misrepresenting Research" (commentary). In Thomasma DC and Kushner T eds., *Ward Ethics*, Cambridge University Press, NY, pp. 244-247, 249-251, 2001.
6. Akabayashi A, Voltz R. Advance Directives in Different Cultures. In Portenoy RK and Bruera E eds., *Topics in Palliative Care* vol. 5, Oxford University Press, New York, NY, pp.107-122, 2001.
7. Lee JS, Kawakubo K, Sato H, Kobayashi Y, Haruna Y. Relationship between total and regional bone miner-

- al density and menopause state, body composition and life style factors in overweight Japanese women. *Int J Obese* 25: 880-886, 2001.
8. Lee JS, Kawakubo K, Kobayashi Y, Mori K, Kashihara H, Tamura H. Effects of ten year body weight variability on cardiovascular risk factors in Japanese middle-aged men and women. *Int J Obese* 25: 1063-1067, 2001.
9. Akabayashi A, Fetters MD. Paying for informed consent. *Journal of Medical Ethics* 26: 3; 212-214, 2000.
10. Fukusaki C, Kawakubo K, Yamamoto Y. Assessment of the primary effect of aging on heart rate variability in humans. *Clinical Autonomic Research* 10: 123-130, 2000.
11. Kashihara H, Ohno H, Tamura M, Kawakubo K, Gunji A. Risk factors for ischemic heart disease in an urban area of Japan: a case-control study in AMHTS. *Method Inform Med* 39: 223-228, 2000.
12. Ishizaki T, Kobayashi Y, Kai I. Functional transitions in instrumental activities of daily living among older Japanese. *Journal of Epidemiology* 10: 249-254, 2000.
13. Akabayashi A, Kai I, Takemura H, Okazaki H. Truth telling in the case of a pessimistic diagnosis in Japan. *The Lancet* 354:1263, 1999.
14. Akabayashi A, Fetters MD, Elwyn TS. Family consent, communication, and advance directive for cancer disclosure: A Japanese case and discussion. *Journal of Medical Ethics* 25 : 4; 296-301, 1999.
15. Miyasaka M, Akabayashi A, Kai I, Ohi G. An international survey of medical ethics curricula in Asia. *Journal of Medical Ethics* 25: 6; 514-521, 1999.
16. Voltz R, Akabayashi A, Reese C, Ohi G, Sass HM. Attitude of health care professionals towards clinical decisions in palliative care: A cross-cultural comparison. *Journal of Clinical Ethics* 10: 4; 309-315, 1999.
17. Akabayashi A. Transplantation from a Brain Dead Donor in Japan. *The Hastings Center Report* May-June 29(3): 48, 1999.
18. Haruna Y, Lee JS, Kawakubo K, Suzuki Y. Cardiovascular reserve to orthostatic stress in active living elders. *J Gravit Physiol* 6: 107-108, 1999.
19. Suzuki Y, Takenaka K, Haruna Y, Akima H, Fukunaga T, Kawakubo K, Gunji A. Relatively shorter but intensive isotonic exercise in legs prevented the decrease in maximal aerobic power after 20 days of head down tilt bed rest in man. *J Gravit Physiol* 6: 117-118, 1999.
20. Oba M, Kawakubo K, Lee JS, Haruna Y, Suzuki Y, and Gunji A. Degraded Diet Induced Thermogenesis Induced by 20-days 6° Head-Down Bed Rest and the Effect of Resistance Training. *J Gravit Physiol* 6: 149-50, 1999.
21. Akabayashi A. Female circumcision - A health issue or a human rights issue. *Health Care Analysis* 6 (1): 55-58, 1998.
22. Takai A., Wongkhomthong S, Akabayashi A, Kai I, Ohi G, Naka K. Correlation between history of contact with people living with HIV/AIDS(PWAs) and Tolerant Attitudes toward HIV/AIDS and PWAs in rural Thailand. *Int J STD and AIDS* 9: 482-484, 1998.

23. Voltz R, Akabayashi A, Reese C, Ohi G, Sass HM. End-of-life decisions and advance directives in palliative care: A cross-cultural survey of patients and health care professionals. *Journal of Pain and Symptom Management* 16: 153-162, 1998.
24. Ohi G, Akabayashi A, Miyasaka M. Japan's health care system as egalitarian: A brief analysis of its history and selected social systems. *Health Care Analysis* 6 (2): 141-149, 1998.
25. Nishimura-Takahashi T, Akabayashi A, Kai I, Cabigon J, Ohi G, Naka K. Social and Behavioral Factors Associated with condom use among female commercial sex workers (CSWs) in Tarlac, the Philippines. *Environmental Health and Preventive Medicine* 2(4): 167-171, 1998.
26. Yanagibori R, Kondo K, Suzuki Y, Kawakubo K, Iwamoto T, Itakura H, Gunji A. Effect of 20 days' bed rest on the reverse cholesterol transport system in healthy young subjects. *J Intern Med* 243: 307-312, 1998.
27. Murakami T, Yamada N, Kawakubo K, Oku J, Mizushima Y, Lino S, Sugimoto T. Lipoprotein abnormalities in non-insulin dependent diabetic patients with ischemic heart disease. *Artery* 22: 206-232, 1997.
28. Akabayashi A. Finally done -- Japan's final decision on organ transplantation. *The Hastings Center Report* Sep-Oct 47, 1997.
29. Akabayashi A. Japan's parliament passes brain-death law. *The Lancet* 349: 9069, 1895, 1997.
30. Voltz R, Akabayashi A, Reese C, Ohi G, Saas HM. Organization and patients' perception of palliative care: A crosscultural comparison. *Palliative Medicine* 11: 351-357, 1997.
31. Gunji. A. Short review of human prolonged horizontal bed rest studies in Japan. *J Gravit Physiol* 4: S1-9, 1997.
32. Akabayashi A. The concept of happiness in oriental thought and its significance in clinical medicine. In *Japanese and Western Bioethics*, Philosophy & Medicine Series 54, Kluwer Academic Publishers, Netherlands, pp.161-164, 1997.
33. Akabayashi A. Questions raised over release of side-effects data in Japan. *The Lancet* 350: 9071, 124, 1997.
34. Sass H, Bonkovsky F, Akabayashi A, Kielstein R, Olick RS. Advance Health Care Documents in Multicultural Perspective. *Ann. Rev. of Law and Ethics*. Band 4, 465-508, 1996.
35. Suzuki Y, Akima H, Igawa S, Fukunaga T, Kawakubo K, Goto S, Makita Y, Gunji A. Decrease of bone mineral density and muscle and/or strength in the leg during 20 days horizontal bed rest. *J Gravit Physiol* 3: 42-43, 1996.
36. Linnarsson D, Sundberg CJ, Tedner B, Haruna Y, Karemaker JM, Antonutto G, Prampero PE. Blood pressure and heart rate responses to sudden changes of gravity during exercise. *Am.J.Physiol.* (Heart Cir. Physiol. 39): H2132-H2142, 1996.
37. Akabayashi A. Financing health care - A Japanese perspective. *Health Care Analysis* 3: 123-125, 1995.
38. Akabayashi A. Open letter to those diet members responsible for legislating Japanese organ transplantation. *Health Care Analysis* 3: 358-360, 1995.
39. Suzuki Y, Haruna Y, Kuriyama K, Kawakubo K, Igawa S, Goto S, Makita Y, Gunji A. Effects of 20 days bed rest on mechanical efficiency during upright cycling and leg muscle mass in young males. *J Gravit Physiol* 2: 74-75, 1995.
40. Haruna Y, Suzuki Y, Yanagibori R, Kawakubo K, Gunji A. Activated renin-angiotensin-aldosterone system and its effects on cardiovascular system during 20-days horizontal bed rest. *J Gravit Physiol* 2: 27-28, 1995.
41. Miyashita S, Haruna Y, Suzuki Y, Gunji A. Effects of posture on cardiorespiratory responses during mild exercise. *J. Phys. The. Sci.* 7: 21-25, 1995.
42. Lee JS, Aoki K, Kawakubo K, Gunji A. A study on indices of body fat distribution for screening for obesity. *J Occup Health* 37: 9-18, 1995.
43. Jeong HS, Gunji A. The influence of system factors upon the macro-economic efficiency of health care: implications for the health policies of developing and developed countries. *Health Policy* 27: 113-40, 1994.
44. Koyano W, Hashimoto M, Gunji A, Fukawa T, Shibata H. The social support system of the Japanese elderly. *Journal of Cross-Cultural Gerontology* 9: 323-33, 1994.
45. Kawakubo K, Gunji A, Sakamoto S, Nakamura F. Exercise-induced ST segment changes and coronary risk factors in asymptomatic men. *Jpn Heart J* 35: 531-532, 1994.
46. Suzuki Y, Kashihara H, Takenaka K, Kawakubo K, Makita Y, Goto S, Ikawa S, Gunji A. Effects of daily mild supine exercise on physical performance after 20 days bed rest in young persons. *Acta Astronautica* 33: 101-11, 1994.
47. Bonde-Petersen F, Suzuki Y, Kawakubo K, Gunji A. Capillary filtration rate, venous compliance, and blood flow in arms and legs do not change during bed rest for 20 days. *J Grav Physiol* 1: 27-8, 1994.
48. Suzuki Y, Murakami T, Kawakubo K, Haruna Y, Takenaka K, Goto S, Makita Y, Igawa S, Gunji A. Regional changes in muscle mass and strength following 20 days of bed rest, and the effects on orthostatic tolerance capacity in young subjects. *J Grav Physiol* 1: 57-8, 1994.
49. Akabayashi A, Morioka M. Ethical issues raised by medical use of brain-dead bodies in the 1990s. *BioLaw* II (48): S531-538, 1991.
50. Akabayashi A, Morioka M. Research on dead persons. *Ann. Intern. Med.* 111 (1): 89, 1989.

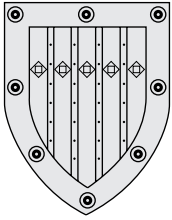

Department of Biostatistics / Department of Epidemiology and Preventive Health Sciences

Outline and Research Objectives

These two departments were established from the department of Biostatistics and Epidemiology in 1996 according to the reorganization of the Graduate School. They are now jointly managed under the supervision of Prof. Ohashi, who moved to the School in 1990 from the University Hospital Computer Center, the University of Tokyo Hospital. When Prof. Ohashi moved to the School, the name of the department was 'Epidemiology' and the name was changed into the above 'Department of Biostatistics and Epidemiology' in 1992 according to the reorganization of the undergraduate and graduate schools and their educational systems. This department was the first official department of biostatistics in Japanese universities, which shows this interdisciplinary and indispensable specialty field required for medical research has been neglected in Japanese university educational system. Now there are three departments of biostatistics; the two others are in Kitasato University (from 1999) and Kyoto University (from 2000), respectively. Our department has, as the first department which can provide comprehensive educational courses in epidemiology and biostatistics from the under-graduate level, brought up and sent many biostatisticians and theoretical epidemiologists to research institutions including Kyoto University, the Ministry of Health, Labor and Welfare and the National Cancer Center as well as pharmaceutical industry.

- (1) Development of statistical-analytical methodology required for medical research including genome data analysis (such as microarray data)
- (2) Development of methodology of clinical trials including data management
- (3) Collaborative epidemiological research (JALS Study described later)
- (4) QOL research
- (5) Outcome research, pharmaco-economical and/or pharmaco-epidemiological research

The last research project is now conducted in collaboration with the department of Pharmacoepidemiology (established in 1993 with the main support from our department) and the department of Pharmaco-economics in the School of Pharmacy. The partnership with the Clinical Bioinformatics Educational Unit, which was just established in 2002, will deepen and expand our research activities especially in the field of clinical epidemiology.

Faculty and Students

Professor and Chair	Yasuo Ohashi Ph.D. (1990-)
Associate	2
Postdoctoral Fellow	3
Graduate student	7 (doctor) 8 (master)
Research student.....	12
Secretary	3

Past Research and Major Accomplishments (number in the parenthesis is the paper in the selected list)

A new methodology of random allocation, the centralized dynamic balancing, was firstly introduced by Ohashi (in 1988 and (1)) into Japan and implemented in many clinical fields rather than oncology, the original application field. The possibility of utilizing Web

(internet) system for registration/randomization was firstly (in the world) discussed in (21) and implemented in the UMIN (University Medical Information Network: one of the largest medical network system managed by the University Hospital Computer Center). As a statistician, Ohashi participated into many clinical trials, especially large-scale long-term clinical trials which had been very rare in Japan until 1990 and contributed to the design, conduct and analysis. Clinical areas include: oncology (37), hematology (25), organ-transplantation, bone-marrow transplantation (45), infectious diseases (8,38), diabetes, cardiovascular diseases (48), hypercholesterolemia (44), cerebrovascular diseases (10,36), kidney diseases (28), neurological disorders and urology (9,32). These collaborative studies stimulated new methodological developments in design and analysis of clinical trials. Examples include:

Fig.1 Clinical Trial Research Model

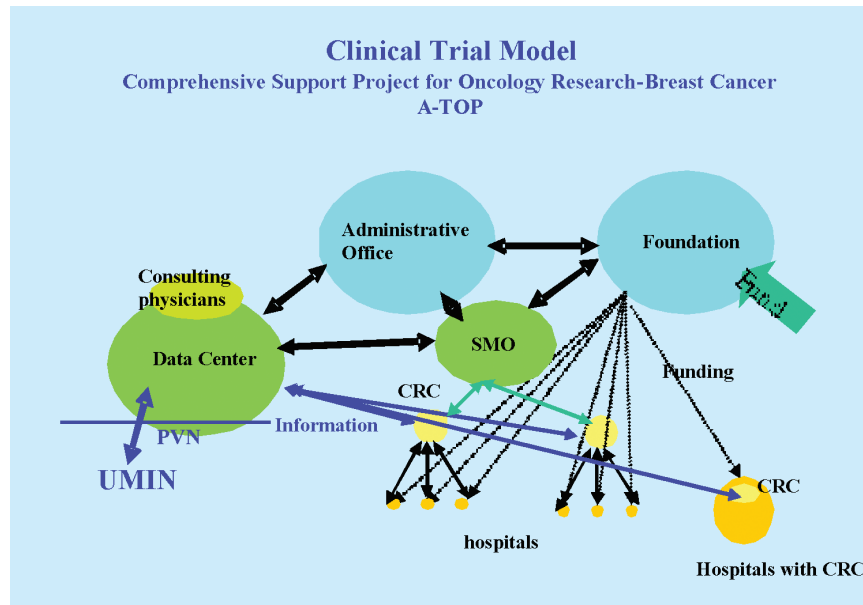

- Bayesian dose-escalation design in early cancer clinical trials (29,50)
- Drug randomization and delivery system using network (35)
- Analysis method for investigating institutional differences (27,33,34,47)
- Analysis method of recurrent events (31)
- Analysis method of bivariate longitudinal data (23,41)

Consultation is a major mission of biostatisticians in medical institutions and contributes to new findings in each research area as well as confirming usefulness of statistical methodology and education of young statisticians. Illustrative examples we experienced include:

- Application of time-dependent covariate analysis (2,4,6)
- Application of kernel smoothing (30)
- Application of cluster analysis (5)

Ohashi and his colleague conducted several meta-analyses of Japanese original oncology drugs, which had been widely used in the surgery adjuvant setting and criticized due to lack of clinical evidence, and provided the data for evaluating the risk-benefit ratio (42). Pharmacoepidemiology is a new active field explored in collaboration with the department of Pharmacoepidemiology. Besides specific researches (15,39), we have established the original adverse-events monitoring system (J-PEM) with participation of pharmacists and published the results of pilot studies (40,49). Some pure epidemiological researches have been conducted by Ohashi and colleagues (19,46), and they are highly evaluated for their rigorous methodology. These experiences lead to a new research area, a prospective collaborative meta-analy-

sis (JALS) of Japanese representative cohort studies which is described later.

QOL research is an interdisciplinary area which requires collaboration with not only care providers but also other specialists such as psychologists and statisticians. Ohashi started pioneering works in Japanese oncology area (12,43) as a statistician and are preparing several papers based on the results of large-scale clinical trials in breast cancer and non-small-cell-lung cancer.

Current Research and Future Prospects

The research objectives described in the earlier section are pursued in collaboration with inside and outside researchers as in the past; the recent topics includes:

- Analysis method for multiple (different type) events
- Joint modeling of longitudinal data and events
- Analysis method for determining the racial difference in drug responses
- Method of sample size re-estimation in clinical trials
- Method of cluster randomization in clinical trials

In addition, new research models emerged recently.

In 2001, Ohashi established a NPO titled Japan Clinical Research Support Unit (J-CRSU) as a chair-person for

- Support for investigator-initiated clinical research through statistical analysis, data management and quality assurance
- Educational support of clinical research methodology and biostatistics, especially education of clinical research coordinators (CRC; research nurses)
- Support for education and dissemination of medical writing and he also started a model project

Fig.2 JALS participating cohorts

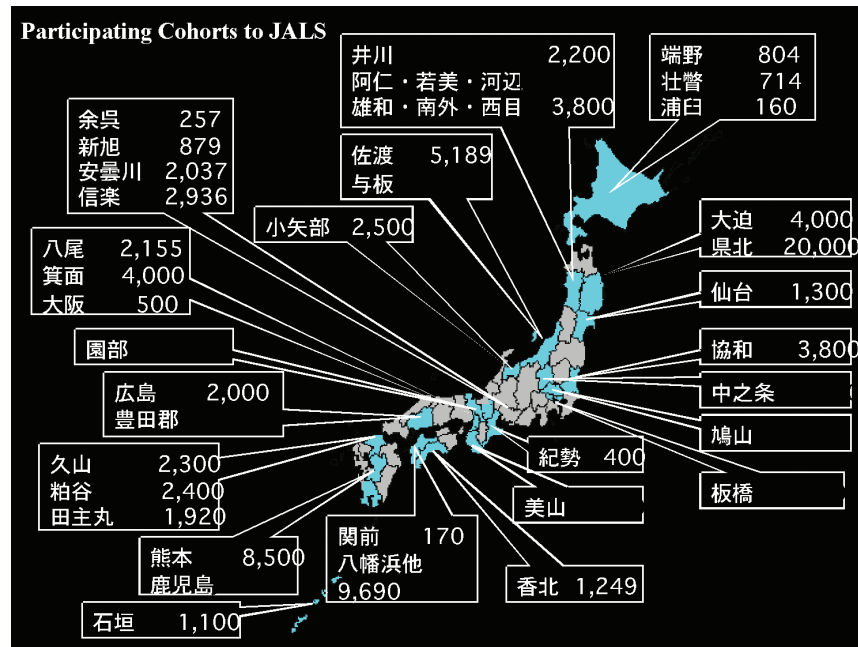

called Comprehensive Support Project for Oncology Research-Breast Cancer (CSPOR-BC) in the Public Health Research Foundation for

- Planning and conduct of investigator-initiated clinical trials for breast cancer patients
- QOL research in oncology
- Education of CRC
- Information support for breast cancer patients and researchers/CRC

The research model is described in Fig.1, where quality control is conducted through the collaboration between data center located in the NPO and CRC dispatched from site management organizations (SMO) or CRC hired in each institution. For increasing efficacy (reducing cost) and keeping security, remote data entry system utilizing UMIN and private virtual network system is designed. Three clinical trials on this scheme are ongoing or will be started by the end of 2002 (2 breast cancer trials (1200 and 2500 patients, respectively) supported by CSPOR-BC and 1 osteoporosis trial (1800 patients) supported by the similar project called A-TOP).

One big epidemiological research project called Japanese Arteriosclerosis Longitudinal Study (JALS) has started from 2001 supported by the Japanese Arteriosclerosis Prevention Fund. The objective of JALS is to conduct a prospective meta-analysis collecting the base-line and follow-up data from individually conducted Japanese cohort studies (including the famous Hisayama cohort) and estimate the gender-age specific incidence rates of cardiovascular and cerebrovascular events as well as quantify the influence of various risk factors. The operation office is located in the NPO and we have conducted the standardization

procedures including standardization of blood-pressure measurements, lipid measurements and developments of the common questionnaires for nutrition intake and physical activities. At present (November, 2002), the cohort size is expected to be 90,000 (regional cohorts) and 25,000 (job-office cohorts) as shown in Fig.2.

All department staffs and students are involved in the above research activities and these models will provide new opportunities of collaboration and education not only for inside persons but also outside researchers and students as well as industry persons.

Recent research topics conducted in these activities include:

- Development of analytical methodology required for meta-analysis
- Validation of physical activity questionnaire using a newly developed instrument measuring acceleration every 4 seconds
- QOL and neurotoxicity by chemotherapy in breast cancer patients
- Epidemiology of postmenopausal symptoms and depression in breast cancer patients

A variety of research fields are expected to emerge from mutual stimulation and enlightenment.

Research Grants

11 grant projects from the Ministry of Health, Labor and Welfare and 1 grant project from the Ministry of Education and Science are ongoing in 2002 including:

- (1) Establishment of the tailor-made strategy for osteoporosis
- (2) Mild hypothermia therapy for severe head injuries in human: a multicenter randomized control trial

- (3) Establishment of novel treatment strategy for breast cancer using cDNA array technology
- (4) Clinical development of new modality of allogeneic hematopoietic stem cell transplantation with a reduced-intensity regime
- (5) Study on establishment of clinical trial system of good quality through cooperative group mechanism

Select Publications (* with reprints)

1. Ohashi Y : Randomization in cancer clinical trials : Permutation test and development of a computer program. *Environmental Health Perspectives*; 87: 13-7., 1990.
2. Funatsu H, Yamashita H, Ohashi Y, Ishigaki T : Correlation between progression of diabetic retinopathy and blood glucose control. *Japanese J. Ophthalmology*; 35: 306-16., 1991.
3. Shiina S, Fujino H, Uta Y, Ohashi Y et al. : Relationship of HbsAg subtypes with HbeAg/anti-Hbe status and chronic liver disease. Part I: Analysis of 1744 HbsAg carriers. *The American J. Gastroenterology*; 86: 866-71., 1991.
4. Funatsu H, Yamashita H, Ohashi Y, Ishigaki T : Effect of rapid glycemic control on progression of diabetic retinopathy. *Japanese J. Ophthalmology*; 36: 356-67., 1992.
5. Suzuki Y, Araie M, Ohashi Y : Sectorization of the central 30° visual field in glaucoma. *Ophthalmology*; 100(1): 69-75., 1993.
- 6*. Yoshimoto M, Sakamoto G, Ohashi Y : Time dependency of the influence of prognostic factors on relapse in breast cancer. *Cancer*; 72(10): 2993-3001., 1993.
7. Yamada N, Gotoda T, Yoshinaga H, Ohashi Y et al : Increased risk factors for coronary artery disease in Japanese subjects with hyperinsulinemia or glucose intolerance. *Diabetes Care*; 17(2): 107-14., 1994.
8. Morikawa Y, Ohashi Y, Harada K, Asai T et al : A multicenter, randomized, controlled trial of intravenous gamma globulin therapy in children with acute Kawasaki disease. *Acta Paediatrica Japonica*; 36: 347-54., 1994.
9. Isaka S, Shimazaki J, Akimoto S, Ohashi Y et al : A prospective randomized trial for treating stages B2 and C prostate cancer : Radical surgery or irradiation with neoadjuvant endocrine therapy. *Japanese J. Clinical Oncology*; 24(4): 218-23., 1994.
10. Sasaki T, Ohta T, Kikuchi H, Ohashi Y et al : A phase II clinical trial of recombinant human tissue-type plasminogen activator against cerebral vasospasm after aneurysmal subarachnoid hemorrhage. *Neurosurgery*; 35(4): 597-605.
11. Matsumoto T, Yamada N, Ohashi Y, Kikuchi M : Coronary heart disease mortality is actually low in diabetic Japanese by direct comparison with the Joslin cohort. *Diabetes Care*; 17(9): 1062-3., 1994.
12. Yasue M, Sakamoto J, Morimoto T, Ohashi Y et al : Evaluation of the effect of pancreatic resection in advanced pancreatic cancer with special reference using hospital-free survival as a measure of quality of life. *Japanese J. Clinical Oncology*; 25: 37-45., 1995.
13. De Mulder PHM, Williams R, Ohashi Y, Blumenstein BA et al : The Design of clinical trials for new therapies in bladder cancer: Is it time for new strategies? *International J. Urology*; 2(Suppl2): 113-6., 1995.
14. Tanimoto K, Nakano K, Kano S, Ohashi Y et al : Classification criteria for polymyositis and dermatomyositis. *The Journal of Rheumatology*; 22(4): 668-74., 1995.
15. Matsuyama Y, Ohashi Y, Uchino H, Takaku F et al : Vesnarinone-induced WBC Disorders in Japan. *Pharmacoepidemiology and Drug Safety*; 5: 87-93., 1996.
16. Sakamoto J, Teramukai S, Koike A, Ohashi Y et al : Prognostic value of preoperative Immunosuppressive Acidic Protein in patients with gastric carcinoma. *Cancer*; 77(11): 2206-12., 1996.
17. Homma Y, Kawabe K, Tsukamoto T, Yamaguchi, O, Ohashi Y et al : Estimate criteria for diagnosis and severity in benign prostatic hyperplasia. *International J. of Urology*; 3: 261-6., 1996.
18. Sato K, Nohtomi K, Shizume K, Ohashi Y et al : 17 β -Estradiol increases calcium content in fetal mouse parietal bones cultured in serum-free medium only at physiological concentrations. *Bone*; 19(3) :213-21., 1996.
19. Honda H, Shimizu Y, Misumi K, Niimi M, Ohashi Y : Cumulative incidence and prevalence of childhood autism in children in Japan. *British Journal Psychiatry*; 169: 228-35., 1996.
20. Ohashi Y, Izumoto T : Comparison of intra-subject variability for different formulation by crossover trials. *F.I.P.Bio-International'96*; 113-8., 1996.
- 21*. Kiuchi T, Konishi M, Bandai Y, Kosuge T, Ohashi Y : A World Wide Web-based user interface for a data management system for use in multi-institutional clinical trials-Development and experimental operation of an automated patient registration and random allocation system. *Controlled Clinical Trials*; 17: 476-93., 1996.
22. Kim -Motoyama H, Yasuda K, Yamaguchi T, Yamada N, Ohashi Y : A mutation of the $\beta 3$ -adrenergic receptor is associated with visceral obesity but decreased serum triglyceride. *Diabetologia*; 40: 469-72., 1997.
- 23*. Matsuyama Y, Ohashi Y : Mixed models for bivariate response repeated measures data using Gibbs sampling. *Statistics in Medicine* 1997; 16:1587-601.
24. Fukuda H, Ohashi Y : A guideline for reporting results of statistical analysis in *Japanese Journal of Clinical Oncology*. *Japanese J. of Clinical Oncology* 1997; 27(3): 121-7., 1997.
25. Ohno R, Miyawaki S, Hatake K, Kuriyama K, Ohashi Y et al : Human urinary macrophage colony - stimulating factor reduces the incidence and duration of febrile neutropenia and shortens the period required to finish three courses of intensive consolidation therapy in acute myeloid leukemia: A double-blind

- controlled study. *J. of Clinical Oncology* 1997; 15(8): 2954-65., 1997.
26. Hukuhara S, Tanabe N, Sato K, Kurokawa K, Ohashi Y : Good Clinical Practice in Japan before and after ICH: Problems and potential impacts on clinical trials and medical practice. *International J. of Pharmaceutical Medicine*; 11: 147-53., 1997.
 - 27*. Matsuyama Y, Sakamoto J, Ohashi Y : A Bayesian hierarchical survival model for the institutional effects in a multi-centre cancer clinical trial. *Statistics in Medicine*; 17: 1893-908., 1998.
 28. Akiba T, Marumo F, Owada A, Ohashi Y et al : Controlled trial of falecalcitriol versus alfacalcidol in suppression of parathyroid hormone in hemodialysis patients with secondary hyperparathyroidism. *American J. of Kidney Diseases*; 32(2): 238-46., 1998.
 29. Furuse K, Kawahara M, Nishiwaki Y, Ohashi Y : Phase I/II study of vinorelbine, mitomycin and cisplatin for stage IIIB or IV non-small-cell lung cancer. *Journal of Clinical Oncology* ; 17-10: 3195-200., 1999.
 - 30*. Hinotsu S, Akaza H, Kotake T, Ohashi Y : Intravesical chemotherapy for maximum prophylaxis of new early phase superficial bladder carcinoma treated by transurethral resection: A combined analysis of trials by the Japanese Urological Cancer Research Group using smoothed hazard function. *Cancer*; 86: 1818-26., 1999.
 - 31*. Matsui S, Ohashi Y : Analysis of recurrent events: Application to a clinical trial of colony stimulating factor with the endpoint of febrile neutropenia. *Statistics in Medicine*; 18: 2409-20., 1999.
 32. Akakura K, Isaka S, Akimoto S, Ohashi Y et al : Long-term results of a randomized trial for the treatment of stages B2 and C prostate cancer : Radical prostatectomy versus external beam radiation therapy with a common endocrine therapy in both modalities. *Urology*; 54-2 : 313-8., 1999.
 33. Skamoto J, Mtsuyama Y, Ohashi Y: An analysis of institutional effects in a multicenter cancer clinical trials- Is it also plausible from the clinicians' point of view-. *Japan Journal of Clinical Oncology*; 29-8: 403-5., 1999.
 34. Yamaguchi T, Ohashi Y : Investigating centre effects in a multi-centre clinical trials of superficial bladder cancer. *Statistics in Medicine*; 18-15: 1961-71., 1999.
 - 35*. Gotoh F, Ohashi Y and the Cilostazol Stroke Prevention Study group: Design and organization of the Cilostazol Stroke Prevention Study. *J. of Stroke and Cerebro-vascular Diseases*; 9: 36-44., 2000.
 36. Gotoh F, Tohgi H, Hirai S, Ohashi Y et al : Cilostazol Stroke Prevention Study : A Placebo-controlled double-blind trial for secondary prevention of cerebral infarction. *J. of Stroke and Cerebrovascular Diseases*; 9: 147-57., 2000.
 37. Takayama T, Sekine T, Makuuchi M, Ohashi Y et al : Adoptive immunotherapy to lower postsurgical recurrence rates of hepatocellular carcinoma: a randomised trial. *The Lancet*; 356: 802-7., 2000.
 38. Morikawa Y, Harada K, Asai T, Ohashi Y et al : Coronary risks after high-dose γ -globulin in children with Kawasaki disease. *Pediatrics International*; 42: 464-9., 2000.
 - 39*. Matsuyama Y, Tominaga T, Nomura Y, Ohashi Y et al : Second cancers after adjuvant tamoxifen therapy for breast cancer in Japan. *Annals of Oncology*; 11: 1537-43., 2000.
 - 40*. Kubota K, Kawabe E, Hinotsu S, Ohashi Y et al : Pilot study of Prescription-Event Monitoring in Japan comparing troglitazone with alternative oral hypoglycemics. *Eur. J. Clin. Pharmacology*; 56: 831-8., 2001.
 41. Toyoda I, Matsuyama Y, Ohashi Y : Estimation and comparison of rates of change in repeated-measures studies with planned dropout. *Controlled Clinical Trials*; 22(6): 620-38., 2001.
 42. Sakamoto J, Teramukai S, Watanabe Y, Ohashi Y et al : Meta-analysis of adjuvant immunochemotherapy using OK-432 in patients with resected non-small-cell lung cancer. *Journal of Immunotherapy*; 24(3): 250-6., 2001.
 43. Fumimoto H, Kobayashi K, Chang C H, Ohashi Y. et al : Cross-cultural validation of an international questionnaire, the general measure of the Functional Assessment of Cancer Therapy Scale (FACT-G) for Japanese. *Quality of Life Research*; 10: 701-9., 2001.
 44. Ito H, Ouchi Y, Saito Y, Ohashi Y. et al : A comparison of low versus standard dose pravastatin therapy for the prevention of cardiovascular events in the elderly: The Pravastatin Anti-atherosclerosis Trial in the Elderly (PATE). *Journal of Atherosclerosis and Thrombosis*; 8(2): 33-44., 2001.
 45. Hiraoka A, Okamoto S, Moriyama Y, Ohashi Y. et al : Phase III study comparing tacrolimus (FK506) with cyclosporine for graft-versus-host disease prophylaxis after allogeneic bone marrow transplantation. *Bone Marrow Transplantation*; 28: 181-5., 2001.
 - 46*. Ohashi Y, Nakai S, Tsukamoto T, Masumori N et al : Habitual intake of lactic acid bacteria and risk reduction of bladder cancer. *Urologia Internationalis*; 68: 273-80., 2002.
 47. Yamaguchi T, Ohashi Y, Matsuyama Y : Proportional hazards models with random effects to examine centre effects in multicentre cancer clinical trials. *Statistical Methods in Medical Research*; 11: 221-36., 2002.
 48. The EPOCH Study Group : Effects of pimobendan on adverse cardiac events and physical activities in patients with mild to moderate chronic heart failure: The effects of pimobendan on chronic heart failure study (EPOCH Study) *Circulation J.*; 66: 149-57., 2002.
 49. Samizo K, Kawabe E, Hinotsu S, Ohashi Y et al : Comparison of losartan with ACE inhibitors and dihydropyridine calcium channel antagonists. A pilot study of Prescription-Event Monitoring in Japan. *Drug Safety*; 25: 811-21., 2002.
 50. Ishizuka N, Ohashi Y : The continual reassessment method and its applications: a Bayesian methodology for phase I cancer clinical trials. *Statistics in Medicine*; 20: 2661-81., 2001.

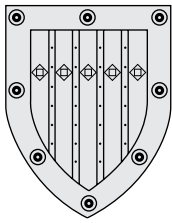

Department of Advanced Clinical Nursing / Department of Nursing Administration

Outline and Research Objectives

The origins of the Departments of Advanced Clinical Nursing and Nursing Administration can be tracked down to the Department of Fundamental Nursing, one of four nursing departments in the School of Health Care and Nursing. In 1953, the School of Health Care and Nursing was instituted at the Faculty of Medicine, the University of Tokyo, as the second 4-year baccalaureate nursing program in Japan. In 1965, the school was reorganized and renamed as the School of Health Sciences, with a focus on health sciences education. Accordingly, the four nursing departments were integrated into one department, the Department of Nursing, which became primarily responsible for undergraduate nursing education at the school until 1992. In that year the school was again, reorganized and renamed as the School of Health Sciences and Nursing, taking on the nation-wide momentum for enhancing baccalaureate programs in nursing. Three departments, including adult health and nursing, family nursing, and community health nursing, were instituted in addition to the Department of Fundamental Nursing (formerly the Department of Nursing). In 1997, as the result of the shift to the chair system of the Graduate School of Medicine, the Department of Fundamental Nursing was reorganized into two graduate departments—the Department of Advanced Clinical Nursing and the Department of Nursing Administration—.

Currently, these two departments are also responsible for undergraduate education in the following subjects: Fundamental Nursing (introductory lectures, skills laboratory, and practicum; 10 credits in total); First Aid and Cardiopulmonary Resuscitation (1 credit); Nursing Research (2 credits); and Nursing Administration (lecture and practicum, 2 credits). The major research activities of the two departments include: studies on the links between nursing quality and patient safety and outcomes; studies on nursing management issues; the development and validation of nursing quality measurements; and physiological studies on human body responses to psychophysiological stress (e.g., patients' responses to invasive treatment, family caregivers' responses to nighttime caregiving activities).

Faculty, Staff, and Students

Professor and Chair	Katsuya KANDA, R.N., PhD. (since 2002)
Associate	2
Graduate student	7
Research student.....	4
Secretary	2

Past Research and Major Accomplishments

The author has primarily been conducting studies on nursing administration, especially on the issue of nursing quality and care delivery management. Secondly, the author has been conducting physiological studies on human body responses to psychophysiological stress and stimulus, such as invasive treat-

ment or intensive caregiving activities.

The author's initial research involvement in the area of nursing administration was a study of nursing home staffing in the United States of America (USA). In 1983, as part of the national strategies to control the ever-increasing medical expenditures in the Medicare reimbursement system, the federal government of the USA introduced the prospective payment system (PPS), utilizing the diagnosis related groups (DRGs) as the payment basis. As a result of the PPS introduction, elderly patients who were not fully recovered from their illnesses were transferred from hospitals to nursing homes. However, the tight budget situation brought about reductions in the number of nursing home staff and the quality of nursing, despite ever-increasing disease severity and care needs of nursing home residents. The author and col-

leagues analyzed the time-series data of multiple nursing homes obtained from a health data center in the state of Pennsylvania, and verified the above-mentioned issue of understaffed nursing homes.

In Japan, the author conducted a series of studies on the links between nurse staffing and patient safety and outcomes. The primary factor affecting the quality of nursing is the nurse-patient ratio. The claim that the understaffing of nurses brings about a too busy working environment for nurses to pay attentions to the details of patient care (which may cause unfavorable consequences to patients) has been an unspoken agreement among nurses for many years. The average length of hospital stay is one of the patient outcome indices that reflect the quality of healthcare and nursing. The author obtained permission from the Ministry of Health and Welfare (MHW) to use the data of "Hospital Reports" surveyed by the MHW, and analyzed the relationship between the number of "nursing staff" (including licensed practical nurses and nurses' aids) assigned per bed and the average patients' length of hospital stay. The data obtained from approximately 7,000 general hospitals were analyzed in this study. The average length of stay among hospitals with a high "nursing staff"-to-bed ratio was shorter than that of hospitals with a low "nursing staff"-to-bed ratio. The average length of stay among hospitals with a high ratio of registered nurses (RNs) to "nursing staff" tended to be shorter than that of hospitals with a low RNs-to-"nursing staff" ratio. Similar results were confirmed after variables related to hospital characteristics (which are known to have a strong link to patient characteristics) were adjusted.

The author then obtained permission from the Management and Coordination Agency to use the data of "Patient Survey" and "Survey of Medical Care Institutions" surveyed by the MHW, and analyzed the relationship between the nurse staffing level approved on the nursing fee schedule of health insurance revenue and the incidence of adverse events, such as complications. The "Patient Survey" data have two variables related to diagnostic classifications (the primary diagnosis and the secondary diagnosis, if applicable). Two nurse researchers with advanced clinical expertise independently evaluated the incidence of adverse events from approximately 295,000 in-hospital patients' survey data. Discrepancies between the two nurse researchers' evaluations were discussed and resolved by incorporating a third nurse researcher's independent evaluation. The result of this adverse event analysis was appalling: the decreased number of nurses per patient was associated with an increased incidence of adverse events; especially, the incidence of adverse events was different between hospitals with a patient-to-nurse ratio of 2.5-to-1 and hospitals with a ratio of 3-to-1.

Japan has fewer numbers of registered nurses assigned to patients in acute care hospitals compared to other developed countries. A large number of registered nurses per patient does not necessarily bring about better quality of care; however, a small number of registered nurses per patient never brings about better quality of care. The author maintains that an adequate number of registered nurses assigned per patient is a "necessity" of better quality of nursing.

In relation to studies of care management, the author and colleagues actually developed and implemented a critical pathway for patients with abdominal aortic aneurysms undergoing surgery. The authors measured the effects of the critical pathway before and after its introduction to a vascular surgical care unit at the University of Tokyo Hospital. A critical pathway is one of the patient care management tools. Multidisciplinary members involved in patient care need to participate in the process of critical pathway development, making suggestions and modifications on pathways from their clinical expertise. Nurses should clarify as to when and for which components of care they are accountable. Therefore, a study of critical pathway implementation is also a study of nursing care itself. Additionally, critical pathways are highly effective for those patients with high-risk diseases who tend to be vulnerable to multiple complications, and without adequate care management, they tend to have delayed recovery and discharge. We disseminated the study results to nurses and educated them, emphasizing that critical pathways are useful for high-risk patients, and that a comprehensive discussion among multidisciplinary team members is necessary during the process of pathway development.

One of the most serious nursing administrative issues involves the frequent uses and their side effects of physical restraint on patients. Regarding physiological studies, the author and colleagues studied the effects of physical restraint on patients via electroencephalography. Elderly healthy volunteers participating in this experimental study with a crossover design received loose physical restraints. Their electroencephalography data showed deviations from normal patterns, despite the fact that they rarely reported subjective discomfort. Nursing research also encompasses patient family members as study subjects. In order to contribute to the knowledge of interventions (the development of supporting systems) for nighttime family caregivers at home, the authors studied the sleep patterns of female family caregivers who were routinely providing nighttime care to bed-ridden elderly individuals. The authors compared their sleep patterns via electroencephalography data with those of an age-matched healthy control group. The study results confirmed that the nighttime family caregiver

group had less slow-wave sleep (deeper sleep stages) than did the control non-caregiver group.

Current Research

A nation-wide healthcare reform, including systematic renovations to the functions of healthcare facilities, is currently underway in Japan in order to improve the efficacy of healthcare delivery systems. Given this situation, healthcare facilities are being classified into two levels: acute care and long-term care facilities. Nurses at long-term care settings need to assume a role different from that of acute care settings. For example, a high proportion of physically dependent or mentally impaired residents (as opposed to residents with medical needs), and a high proportion of care workers who are responsible for residents' personal care and assistance in their daily life activities are characteristic to long-term care settings. The authors have just completed part of a survey involving nurses' roles, clinical expertise, job assignment and sharing in relation to care workers, and staffing levels necessary to maintain a good quality of care at long-term care settings, such as health services facilities for the elderly or sanatorium-type wards of hospitals.

The history of research on nursing care quality and the methods of quality evaluation are very new to Japan; the availability of such data is very limited. The authors are conducting studies to identify and establish patient outcome indicators that have: (1) known empirical or theoretical strong links to the quality of nursing; (2) reliable and accurate information widely available to the majority of facilities; and (3) ease of measurement or ease of access to information sources. The authors are also attempting to standardize data collection methods of such quality indicators. The authors conducted a pilot study at a facility, identified quality indicators meeting the above-mentioned criteria, and developed a trial version of standardized data collection methods. A follow-up study at multiple sites is underway in order to validate the utility of these indicators and methods.

Regarding studies on critical pathways, the authors are currently conducting a study to examine the utility of critical pathways in rehabilitation settings in addition to acute care settings. Specifically, the authors are conducting a study of critical pathways for patients with hip fractures undergoing surgery, comparing the data from multiple sites regarding the entire process of introduction and revisions of critical pathways, and the efficacy of the process.

Regarding studies of physical restraint, the authors are examining an application of alternative and complementary therapies that are recently attracting public attention as a method of alleviating psychological stress. When physical restraints are unavoidable with

an understanding of their risks and unfavorable effects, can we alleviate the psychosomatic distress of patients who are under restraint by using aroma therapy? We conducted an experimental study with a control group in order to measure the relaxing effects of lavender aroma on individuals under physical restraint. Currently, we are analyzing the electroencephalography and electrocardiography data. Additionally, we are conducting a study to compare the effects of the chair-sitting position (with the upper body upright and detached from the back of a chair) and of the wheelchair-reclining position (with the upper body reclined on the back of a wheelchair) on activities in the autonomous nervous system. Part of the literature and practice guidelines suggest the use of the chair-sitting position instead of the widely and frequently used wheelchair-reclining position for physically dependent or mentally impaired elderly individuals. Some evidence supports the notion that the wheelchair-reclining position, given that the upper body is totally reclined onto the back of the wheelchair, may decrease their ability to maintain their body position, or may decrease activities in the autonomous nervous system (as well as mental alertness).

Future Prospects

First, the long-term objective of research on nursing administration includes the development and validation of standardized methods and measurements (indices) of patient outcomes related to the quality of nursing. A nation-wide database of nursing quality indicators should be developed, starting off with inviting a certain number of hospitals willing to participate in the study. Continuous quality improvement in healthcare and nursing involves organizational efforts to identify their own national rankings and to renovate themselves through system-wide learning and changing. Such efforts of national database development and benchmarking would enable comparisons among organizations and would provide opportunities for them to learn from top-ranked organizations. When the nursing profession establishes such a national database of quality indicators, the author believes that this profession would be able to take political action and make suggestions with convincing evidence to the government regarding concrete strategies for improving the quality of nursing. The author would also like to conduct studies on the reliability and sensitivity of quality indicators in order to increase the validity of the comparisons.

Secondly, nursing research must provide convincing evidence that nursing can contribute to the health promotion of individuals/family/community (or the optimization of their health experiences), so that the efficacy of nursing is reasonably recognized by the

public. The effectiveness of nursing, including patients' psychophysiological responses to care, tended to be addressed more by anecdotal experiences than by scientific studies providing evidence. "Evidence-based nursing" is currently a widely-used catch phrase in Japan; however, the evidence regarding the effectiveness of care is still very weak. The author believes that the Departments of Advanced Clinical Nursing and Nursing Administration, which are responsible for the fundamentals of nursing and skills laboratories in undergraduate education, are also responsible for conducting studies on the efficacy of nursing. With respect to critical pathways, many retrospective studies have been conducted so far by nurse researchers in Japan. The author is planning to conduct a prospective and comparative study on the effectiveness of critical pathways in order to obtain more reliable and convincing evidence than that previously obtained. The author believes that randomized comparative studies from multiple sites are necessary to conduct in the future.

Finally, nursing informatics is one of the areas of research and education still underdeveloped in these departments. The author strongly believes that research and educational programs of nursing informatics need to be developed in the future because of the following reasons: (1) The implementation of a better quality of nursing and an evaluation on its outcomes involves the development of evaluation criteria and standards on the performance and quality of nursing, and the actual implementation of evaluation measures and procedures, thus ensuring accurate and high-quality information on healthcare and its administration; and (2) The study of nursing informatics lays the foundation of practice, administration, education and research in nursing. Informatics in nursing provides meaningful links among these areas and promotes development in each of these areas of nursing.

Research Grants

1. Principal Investigator: Physical Restraint of the Elderly in Institutional Care Setting and Alternatives to Restraint Use. Grant-in-Aid for Scientific Research, funded by the Ministry of Education, Science and Culture, 1996-1997.
2. Principal Investigator: Economic Evaluation of Nursing Services. Grant-in-Aid for Health Sciences Research, funded by the Ministry of Health and Welfare, 1996-1998.
3. Principal Investigator: Nurse Staffing and Nurses' Job by Type of Healthcare Facility. Grant-in-Aid for Health Sciences Research, funded by the Ministry of Health and Welfare, 1999-2001.
4. Principal Investigator: Effect Verification of Development and Implementation of Critical Pathway for Hip Fracture. Funded by Japanese

Nursing Association, Project of Promotion of Infrastructure Improvement for Nursing Policy Planning, 2001.

Select Publications

1. Minamisawa H, Takeo K, Kanda K. Body positions and heart rate: focusing on patient's daily life. *Nursing* 33(12): 44-51, 1981. (in Japanese)
2. Tagami Y, Hatano H, Hashimoto M, Kanda K, Tanaka T. A study on the distribution of medical facilities in small cities. *Hospital Administration* 19: 257-284, 1982. (in Japanese)
3. Takeo K, Minamisawa H, Kanda K, Hasegawa S: Heart rates during the daily activity of "Zen" priests. *Journal of Human Ergology* 13: 83-87, 1984.
4. Kanda K. Promotion of home care and visiting nursing. *The Tokyo Journal of Medical Science* 95: 387-390, 1988. (in Japanese)
5. Takeo K, Minamisawa H, Kanda K, Tukamoto M, Kimura K, Mori Y, Ishida M, Watanuki S. Daily activity and food intake in patients with senile dementia. *Annual Report of Sasakawa Health Science Foundation*, 5(2), 103-112, 1989. (in Japanese)
6. Kanda K, Minamisawa H. How do nurse practitioners use their time? In "The Improvement of the Quality of Nursing Care by Introducing Primary Nursing," Report of Grant-in-Aid for Scientific Research from the Ministry of Education, Science and Culture (pp. 65-82), 1990. (in Japanese)
7. Kanda K, Mezey M: Registered nurse staffing in Pennsylvania nursing homes: Comparison before and after implementation of Medicare's Prospective Payment System. *Gerontologist* 31: 318-324, 1991.
8. Kanda K, Maitoko M, Shimada Y, Takenawa N, Awaya N, Mitoh M. How much are nurses performing other health care professionals' duties in hospitals? *Japanese Journal of Nursing Administration* 1: 371-376, 1991. (in Japanese)
9. Kanda K, Takahashi M, Fujieda C. Nurse staffing at outpatient clinics. *Japanese Journal of Nursing Administration* 2: 55-61, 1992. (in Japanese)
10. Kanda K, Takahashi M, Fujieda C. Activities and functions performed by nurses in ambulatory care setting. *Japanese Journal of Nursing Administration* 2: 179-185, 1992. (in Japanese)
11. Fujieda C, Takahashi M, Bojo N, Miyamoto A, Kanda K. A survey on the levels of staffing by nurses in hospitals. *Japanese Journal of Nursing Administration* 2: 307-311, 1992. (in Japanese)
12. Kanda K, Fujieda C, Takahashi M, Bojo N, Miyamoto A. Nurse staffing mechanism with relevance to case mix of patients. *Japanese Journal of Nursing Administration* 2: 363-370, 1992. (in Japanese)
13. Kanda K, Takahashi M, Fujieda C, Bojo N, Miyamoto A. Actual condition of hospital structure and equipment influencing nursing service. *Japanese Journal of Nursing Administration* 3: 52-55, 1993. (in Japanese)
14. Kanda K. Trend of registered nurse staffing in nursing homes. Report of Research Activities by

- Sasakawa Health Science Fellowship Grantees, 7-17, 1993. (in Japanese)
15. Maitoko M, Kanda K. Factors effecting medication errors. *Journal of Japan Academy of Nursing Science* 13(2): 29-36, 1993. (in Japanese)
 16. Kanda K, Kusakari J, Awaya N. A study on the characteristics and length of employment of nonrotating-shift night nurses. *Hospital Administration* 30: 215-222, 1993. (in Japanese)
 17. Mitoh T, Takeo K, Minamisawa H, Kanda K, Hirose H. A study to determine necessity of QOL and ADL evaluation and care of institutionalized senile elderly. Report of Grant-in-Aid for Scientific Research from the Ministry of Education, Science and Culture, 1993. (in Japanese)
 18. Maitoko M, Kanda K. An approach to evaluation of quality of nursing, focusing on medication errors. *Japanese Journal of Nursing* 58: 122-125, 1994. (in Japanese)
 19. Kanda K. Proportion of high-acuity patients according to hospital characteristics. *Journal of Japan Academy of Nursing Science* 15(4): 9-14, 1995. (in Japanese)
 20. Kanda K, Watanuki S, Kunioka T, Tama E, Kojima Y. The development and increased use of machinery and equipment in nursing: Current availability and usage. *Japanese Journal of Nursing Administration* 6: 742-747, 1996. (in Japanese)
 21. Kanda K, Watanuki S, Kunioka T, Tama E, Kojima Y. The development and increased use of machinery and equipment in nursing: Issues related to future development and increased usage. *Japanese Journal of Nursing Administration* 6: 834-841, 1996. (in Japanese)
 22. Sakaguchi M, Kanda K, Sakai I, Chen JX, Tamura Y, Shiga Y, Takeo K: Survey on the care needs of persons with health problems and their families living in urban areas of Japan. *Journal of Shiga Academic Society of Nursing Science* 1: 15-19, 1996.
 23. Kanda K, Koike J. Predicting quantity of care needs and nursing intensity. In "Measuring Care Needs of Patients in Medical Care Institutions," Report of Grant-in-Aid for Health Sciences Research from the Ministry of Health and Welfare (pp. 29-35), 1996. (in Japanese)
 24. Kanda K, Sato R, Nagata A. Effects of intermittent wakening on sleep pattern of nighttime caregiver: An EEG study with a single subject. *Journal of Japan Academy of Nursing Science* 17(1): 75-81, 1997. (in Japanese)
 25. Kojima M, Horiuchi S, Ota K, Oikawa I, Kaharu C, Nomura M, Toyomasu K, Hatono Y, Kanda K, Tanaka Y. A study of nursing systems in transition in developed countries. *Bulletin of St. Luke's College of Nursing* 23: 49-68, 1997. (in Japanese)
 26. Kanoya Y, Domon Y, Sato R, Kanda K. The nurses' contribution to the quality improvement of care under the health care policy to contain costs: a review. *Japanese Journal of Nursing Administration* 7: 668-675, 1997. (in Japanese)
 27. Kanda K. Association of nursing service with length of hospital stay of patients. *Japanese Journal of Nursing* 61: 1018-1022, 1997. (in Japanese)
 28. Sato R, Osaka Y, Nomura I, Fuse S, Kanda K. Nurses' selection of analgesics and the frequency of their administration to the patients in 24 hours after transcatheter arterial embolization, transcatheter arterial infusion, and transcatheter hepatic angiography. *Japanese Journal of Nursing Arts* 44: 1001-1006, 1998. (in Japanese)
 29. Watanuki S, Kanda K, Kimura K, Minamisawa H, Mori Y, Takeo K, Tsukamoto M. Body weight loss and BMI(Body Mass Index) decrease of hospitalized elders with senile dementia. *Journal of Japan Academy of Nursing Science* 18(2): 51-62, 1998. (in Japanese)
 30. Sato R, Kanda K, Nagatomo M, Kusakari J. Relationships between task performance of visiting care agencies and physicians' orders. *Hospital Administration* 35: 177-184, 1998. (in Japanese)
 31. Matsumoto A, Kanda K. Concept and effects of discharge planning. *Japanese Journal of Nursing Arts* 44: 710-713, 1998. (in Japanese)
 32. Kanda K. Physical Restraint of the Elderly in Institutional Care Setting and Alternatives to Restraint Use, Report of Grant-in-Aid for Scientific Research from the Ministry of Education, Science and Culture, 1998. (in Japanese)
 33. Nagatomo M, Kanda K, Sato R, Kusakari J. Relationship between physicians' orders and nurses' service sphere of activity -- a comparison between home health care agencies and university hospitals. *Hospital Administration* 36: 5-16, 1999. (in Japanese)
 34. Kanda K, Sato R, Kodama S, Takemura Y, Matsumoto A. Relations between nurse-staffing levels and adverse outcomes. In "Economic Evaluation of Nursing Services," Report of Grant-in-Aid for Health Sciences Research from the Ministry of Health and Welfare (pp.16-41), 1999. (in Japanese)
 35. Sato R, Kanda K, Anan M. Sleep patterns of middle-aged and older female family caregivers providing routine nighttime care for elderly individuals at home. *Journal of Japan Academy of Nursing Science* 20(3): 40-49, 2000. (in Japanese)
 36. Kanda K, Takemura Y. Research agenda for critical pathways. *Japanese Journal of Nursing Research* 33: 221-230, 2000. (in Japanese)
 37. Kanda K, Sato R, Matsumoto A, Yamagishi M, Takemura Y. Nurse Staffing and Nurses' Job by Type of Healthcare Facility -- Job and Role Expectations of Nurses in Health Services Facilities for the Elderly, Report of Grant-in-Aid for Health Sciences Research from the Ministry of Health and Welfare, 2000. (in Japanese)
 38. Zhao H, Kanda K. Translation and validation of the Standard Chinese version of the EORTC QLQ-C30. *Quality of Life Research* 9: 129-137, 2000.
 39. Takemura Y, Kanda K. The elements and the process of 'good nursing practice' perceived by nurses.

- Japanese Journal of Nursing Research 34: 329-339, 2001. (in Japanese)
40. Kanda K, Sato R, Emori K, Takemura Y, Matsumoto A, Ogawa R. Nurse Staffing and Nurses' Job by Type of Healthcare Facility -- Role and Job of Nurses in General Clinics, Report of Grant-in-Aid for Health Sciences Research from the Ministry of Health and Welfare, 2001. (in Japanese)
 41. Kanda K, Zhao H, Takahashi Y. Quality of life in Chinese patients with gynecological cancer. Proceedings of the 2nd Conference on Nursing Education & Research between School of Nursing, Seoul National University and School of Health Sciences & Nursing, The University of Tokyo : 6-10, 2001.
 42. Kawana N, Ishimatsu S, Kanda K. Psycho-physiological effects of the sarin attack on the Tokyo subway system. *Military Medicine* 166 Suppl. 2:23-26, 2001.
 43. Ibe T, Ichiduka K, Kawano R, Kanda K, Moriwaki M, Yanagisawa H. Actual Condition of Nurses as Clinical Research Coordinators: Comparison of the Results Surveyed in 1998, 1999 and 2000. Japanese Nursing Association, 2001. (in Japanese)
 44. Kanda K, Takemura Y, Ogawa R, Yamagishi M, Kodama S. Nurse Staffing and Nurses' Job by Type of Healthcare Facility -- Role and Job of Nurses in Sanatorium-type Wards of General Hospitals, Report of Grant-in-Aid for Health Sciences Research from the Ministry of Health and Welfare, 2002. (in Japanese)
 45. Yamagishi M, Kanda K, Takemura Y. Development of methods for detecting occurrences of adverse events as nursing quality indicators. *Journal of Japan Society for Health Care Management* 3: 363-369, 2002. (in Japanese)
 46. Matsumoto A, Kanda K, Shigematsu H. Development and implementation of a critical pathway for abdominal aortic aneurysms in Japan. *Journal of Vascular Nursing* 20:14-21, 2002.
 47. Kanda K, Ozawa M, Irimura R. Allocation of nursing time at university hospitals in Japan. *Journal of Nursing Studies National College of Nursing, Japan* 1: 17-26, 2002.
 48. Kanda K, Kodama S. Determinants of nursing service in urban public hospitals: An economic perspective. *Nursing and Health Sciences* 4: 63-72, 2002.
 49. Takemura Y, Kanda K, Matsumoto A, Yamagishi M. Role expectations of nurses in health service facilities for the elderly. *Nursing and Health Sciences* 4: 73-83, 2002.
 50. Sato R, Kanda K, Anan M, Watanuki S. Sleep EEG patterns and fatigue of middle-aged and older female family caregivers providing routine nighttime care for elderly persons at home. *Perceptual and Motor Skills* (in press).

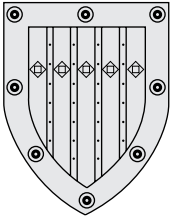

Department of Adult Nursing / Terminal and Long-term Care Nursing

Outline and Research Objectives

The origin of the Department of Adult Nursing /Terminal and Long-term Care Nursing was "Department of Adult Health" in the School of Health Sciences (1965-1992), and after that "Department of Adult Health and Nursing" in the School of Health Sciences & Nursing (1992-).

From 1995 to 1997, the Graduate School of Medicine shifted to the chair system of Graduate Schools, and our new two departments were established. The members of two departments cooperate in education and research together.

Our major research objectives are concerning followings issues.

1. Cancer Nursing
2. Adult Health Nursing
3. Nursing Care System for Outpatients
4. Evaluation of Palliative Care Services
5. Spiritual Care for Terminally Ill Persons and Their Families
6. Continuity in Palliative Care System
7. Dissemination of Palliative Care
8. Methodology of Nursing Research and Education

Faculties and Students

Professor and Chair	Keiko Kazuma, M. of Hlth.Sc., The Univ. of Tokyo, School of Health Sciences, 1976; Dr. Hlth.Sc., The Univ. of Tokyo, 1989. Since 1999
Lecturer	Masako Kawa, M. of Hlth.Sc., The Univ. of Tokyo, School of Health Sciences, Since 1996
Associate	2
Postdoctoral Fellow	4
Graduate student	14 (Dr. program;6, Ms. program;8)
Research student.....	7
Secretary	1

Past Research and Major Accomplishments

1. Cancer Nursing

One of the main subjects of our cancer nursing research is cancer risk counseling, especially in genetic counseling of patients and /or kindred of patients with familial cancer syndrome, expressed in adulthood. In genetic counseling, ethical consideration is very important for application of gene testing. At present, prophylactic surgery is the first choice as a

preventive strategy for familial cancer syndrome expressed in adulthood. We have studied clients' needs and the role of nurse-counselors, based on their background of familiarity and practical experiences with perioperative management and intervention for adaptation to the patients' altered intestinal structure after surgery. We developed a decision tree for the process of cancer risk counseling based on the foreign literature and our clinical experience with familial adenomatous polyposis family. The decision tree was agreed with peer group of cancer genetic counseling and is introduced in seminars for familial cancer counselors.

Another concern is intervention to facilitate adaptation after cancer surgery. We developed a measurement scale for feeling of stability in daily life with a stoma for people with a permanent colostomy because of malignancy, and explored the factors influencing the feeling of stability. The results showed that the frequency of the stoma clinic and support from nurses contributed to that feeling

2. Adult Health Nursing

The domain of adult health nursing contains work concerning health promotion and symptom management. For the former, a brisk walking program was applied for the middle nurse managers, a group that tends to lack of exercise. Several positive effects in

serum characteristics were approved in the intervention group compared to control group.

The subjects of symptom management research were patients who underwent surgery for gastrointestinal disease or inflammatory disease. After gastrectomy, we found that increased symptoms were related to changes in eating behavior associated with return to the workplace, and it was suggested the necessity of intervention after discharge. A measurement scale was also developed to evaluate difficulties in daily life after surgery for oral tumor.

The subjects of symptom management for inflammatory disease were patients with ulcerative colitis (UC) or rheumatoid arthritis (RA). UC patients experience difficulties in daily life related to decreased vigor and altered defecation. We developed an instrument to measure the difficulties of life, and explored the factors influencing it. For RA patients, a series of studies was carried out on association with fatigue, coping behavior, and nutrition, and an exploratory study was implemented on home exercise and the factors influencing it.

3. Nursing Care System for Outpatients

Recently, nurses' role in hospital outpatient departments and in home care settings has been changing dramatically, because of the shortening of hospital stays, changes in types of disease, and increasing elderly population. Several surveys were conducted on nurses' recognition of the care needs of outpatients, evaluation of nurses' activities for outpatients, and fact-finding about consultation and teaching activities by nurses throughout Japan (dental university hospital, and all hospitals above 200 beds).

4. Evaluation of Care Services in Palliative Care Institutions

It was difficult to investigate quality of life in vulnerable patients, so that it was assumed that the effectiveness of palliative care could be clarified by clinical audit, which is the systematic critical analysis of the quality of clinical care by the audit tool instead of the QOL questionnaire. Therefore research by the audit tool was instituted. The feasibility of the Support Team Assessment Schedule (STAS) and Edmonton Symptom Assessment System (ESAS), developed abroad as an audit tool, was examined in two palliative care units. In this study we collaborated with a research group investigating the reliability and validity of the Japanese version of the STAS.

5. Spiritual Care for Terminally Ill Persons and Their Families

This theme resulted from the spiritual pain discovered in reviewing patients' complaints of distressing conditions recorded on their charts. The study on

spirituality was undertaken as collaborative research with other universities. After a literature review, interviews were conducted with patients admitted to palliative care units, and the data from the interviews were analyzed by Grounded Theory Approach.

6. Continuity in the Palliative Care System

We used a questionnaire to investigate the status and needs of people attending hospice clinics. The results showed that consultation in which patients decide where to stay should be provided at an appropriate time before referral to a palliative care institution.

7. Promotion of Palliative Care;

A member of the teaching staff of our department joined the working group on "Attitudes toward terminal care" in research implemented by the Ministry of Health and Welfare in 1998. The results showed that palliative care needed to be further understood by both the general public and the clinical staff. We subsequently conducted a survey of nurses working in general hospitals to investigate the difficulties encountered in the care of terminally ill cancer patients and related factors.

8. Methodology of nursing research and education;

This contains several issues, including surveys and critiques for application of statistical techniques in nursing research, review of utilization of the concentric circle model of body extremities as a non-invasive measurement tool, and concerning the nursing process, nursing diagnosis, and terminology in nursing.

Current Research

1. Cancer Nursing;

To establish nurses' role in cancer genetic counseling in Japan, we have joined a research project with MDs in a continuous study group.

Negotiations concerning to a prospective cohort study of people with a stoma is in progress with the aim of collaboration between our group and other institutions concerning the process of how to acquire a feeling of stability

2. Adult Health Nursing

Concerning about health promotion, we started a collaborative research program on physical activity and physical component in frail elderly with a Korean group at Seoul National University to promote health.

Symptom management research is conducted in UC patients after total colectomy. Difficulties in a tem-

porally ileostomy period are focused on. We are analyzing the cross-sectional data from 84 patients whether related or not to body weight loss in that period. And despite of case studies with a few patients, we ascertained that body weight loss and hypoglycemia were not appeared in patients for whom educational intervention was period about how to eat in that period.

3. Nursing Care System for Outpatient

Nursing function and efficiency in hospital outpatient department is being surveyed with diabetics not using insulin as the model, and a prospective cohort study is being planned.

4. Evaluation of Palliative Care Services

The study of the reliability and validity of the Japanese version of the STAS has just been completed. We are now preparing a booklet to encourage use of this tool in clinical settings. We are also participating in a study group that is establishing evaluation criteria according to the peer review method developed in the UK.

5. Spiritual Care for Terminally Ill Persons and Their Families

Interview data are being analyzed and some of the results are being prepared for submission to a foreign journal. Next, we must plan a study on appropriate spiritual care for terminally ill persons.

6. Continuity in the Palliative Care System

We obtained a grant for Day Care research. Preparation for needs assessment prior to development of a day care program is in progress. Research on consultation and support for patients discharged from cancer centers is also continuing.

7. Promotion of Palliative Care;

Barriers to palliative care are being examined to promote palliative care in general practice. In addition, research on palliative care for other chronic illnesses is being planned.

8. Methodology of nursing research and education

Projects of terminology in nursing are being continued in International Classification of Nursing Practice (ICNP) and nursing actions in Japan.

Future Projects

Both departments intend to continue to develop current research projects. A new project is being considered: making the measurement scales we developed available on our homepage. This project will be

very useful in refining the scales and compiling clinical data.

Research Grants

1. Keiko Kazuma: The Ministry of Education, Culture, Sports, Science and Technology (MEXT), Grant-in-aid for Scientific Research (C); The Development of Nursing strategy for the postoperative patients with lower gastro-intestinal Diseases (2,300,000 yen, Representative researcher, 2000-2003).
2. Keiko Kazuma: The Ministry of Health, Labor and Welfare (MHLW), Grant-in-aid for Scientific Research; Nursing function of outpatient department in hospital for chronically ill people (6,500,000 yen;2002, Collaborative researcher, 2002-2003).
3. Keiko Kazuma: Japan Society for the Promotion of Science (JSPS), The Japan-Korea Basic Scientific Cooperation Program; A Comparison of Bio-psychosocial status related to Physical Activity of the Elderly between Korea and Japan: Biophysical Index, Health status, Competence of Daily Activity and Depression. (2,400,000 yen, Representative researcher, 2002-2004).
4. Masako Kawa : The Mitsubishi Foundation, Grant for Social Welfare Activities and Research; Basic study on the development of spiritual care for the well-being of terminally ill patients with cancer. (2,000,000 yen, 2000-2001.)
5. Masako Kawa : Japan Society for the Promotion of Science (JSPS), Grant-in-aid for Scientific Research (C); The development of palliative day care program for the persons with advanced cancer. (3,900,000 yen, Representative researcher, 2002-2004.)

Select Publications

1. Imamura Y, Ozawa T, Miyashita M, Kawa M, Kojima M. Consultation service at hospice clinic and information given at referrals on hospice and palliative care: The attitude among terminally ill patient with cancer and family members. *J Jpn Soc Cancer Nurs* 13(2): 60-68., 1999. (in Japanese)
2. Ojima T, Nakamura Y, Hashimoto S, Miyashita M, Hayashi M, Kato M, Matsumura Y, Fukutomi K. The development of the regional health and welfare indexes. *Journal of Health and Welfare Statistics* 46(15): 3-9., 1999.(in Japanese)
3. Takeda Y. Parents' attitudes to predictive genetic testing in their children for familial adenomatous polyposis. *The Ochanomizu Medical Journal* 47(3): 129-146., 1999. (in Japanese)
4. Koike T. The relationship between fatigue and nutritional status in patients with rheumatoid arthritis. *The Ochanomizu Medical Journal* 48(3·4): 95-107., 2000. (in Japanese)
5. Furuse K, Kawahara M, Nishiwaki, Fukuoka M, Takada M, Miyashita M, Ohashi Y. Phase I/II study of vinorelbine, mitomycin, and cisplatin for stage

- IIB or IV non-small-cell lung cancer. *Journal of Clinical Oncology* 17(10): 3195-3200., 1999.
6. Ito N, Miyashita M, Kojima M. The self-care ability and medical/social support in ostomates. *J Jpn Soc Cancer Nurs* 1999. 13(1): 25-34., (in Japanese)
 7. Miyashita M, Hashimoto S, Kawa M, Kojima M. Attitudes towards terminal care among the general population and medical practitioners in Japan. *Japanese Journal of Public Health* 46(5): 391-400., 1999. (in Japanese)
 8. Matsumura Y, Nakamura Y, Hayashi M, Kato M, Miyashita M, Ojima T, Hashimoto S, Fukutomi K. Prefectural differences of the proportion of the smoking population. *Journal of Health and Welfare Statistics* 46(6): 23-28., 1999. (in Japanese)
 9. Miyashita M, Hashimoto S, Ojima T, Nakamura Y, Hayashi M, Kato M, Fukutomi K. An estimation of the proportion of handicapped people and health expectancy for aged person: prefectural estimation based on existing health statistical resources. *Journal of Health and Welfare Statistics* 46(5): 25-29., 1999. (in Japanese)
 10. Hashimoto S, Miyashita M, Tsuji I, A comparison of calculation method for health expectancy. *Journal of Health and Welfare Statistics* 46(4): 12-16., 1999. (in Japanese)
 11. Hayashi M, Hashimoto S, Kato M, Ojima T, Nakamura Y, Miyashita M, Fukutomi K. The importance or regional health and welfare indexes. *Bulletin of Fukushima school of nursing* 1: 33-38., 1999. (in Japanese)
 12. Kazuma K, Kawagoe H, Kawamura S, Yamazaki M. Development of the nursing protocol for management of medical treatment in home care, (1) The fact finding study of visiting nurse station providing management of medical treatment. *Kango* 51: 110-116., 1999. (in Japanese)
 13. Kazuma K, Kawagoe H, Kawamura S, Yamazaki M. Development of the nursing protocol for management of medical treatment in home care, (2) The fact finding study of visiting nurse station providing management of medical treatment. *Kango* 52: 108-114., 1999. (in Japanese)
 14. Kitano K, Kawamura S, Kazuma K. A study on working women caring for their husbands with an intractable disease. *J J Intrac Ill Nurs* 3: 53-66., 1999. (in Japanese)
 15. Mizuno Y, Ogura A, Kawamura S, Kazuma K. Study on planning and nursing management for safe outside activities for ventilator-assisted-individuals. *J J intrac Ill Nurs*, 3: 42-52., 1999. (in Japanese)
 16. Amano S, Kawamura S, Kazuma K, Ushikubo M. Protocol of pressure ulcers management in home health care-algorithm of nutritional assessment and management. *J Jpn Acad Home Health Care*, 2: 51-59., 1999. (in Japanese)
 17. Kazuma K. Utilization of the concentric circle model in clinical nursing: a Review. *Journal of Medical and Dental Sciences*. 46(4): 139-143., 1999.
 18. Takeda Y, Kazuma K. The nurses' role in cancer genetic testing and counseling. *Nursing Today*, 14: 72-74., 1999. (in Japanese)
 19. Kazuma K. The Current of nursing process and nursing diagnoses. *Jpn Nurs Admin*, 9: 671-677., 1999. (in Japanese)
 20. Kawa M. Supporting the bereaved family. In Ohba M, Endo E, and Inayoshi M (eds.). *The new cancer nursing*, Brain Press, Tokyo 361-365., 1999. (in Japanese)
 21. Kawa M. The subjects to be studied in palliative care. In Ohba M, Endo E, and Inayoshi M (eds.). *The new cancer nursing*, Brain Press, Tokyo 366-374., 1999. (in Japanese)
 22. Kazuma K, Takeda Y: Genetic counseling in cancer nursing, in Ohba M, Endo E, Inayoshi M (eds.). *New cancer nursing*, Brain Press., 59-71., 1999. (in Japanese)
 23. Okusaka k, Kazuma K. Investigation of changes in symptoms and eating behavior associated with the return to the workplace of postgastrectomy patients. *J Jpn Acad Nurs Sci* 20(3): 60-68., 2000.
 24. Koike T, Kazuma K, Kawamura S. The relationship between fatigue, coping behavior, and inflammation in patients with rheumatoid arthritis. *The Japan Rheumatism Association and Springer-Verlingere Tokyo 2000. Mod Rheumatol*. 141-149, 2000.
 25. Hashimoto M, Koike T. Development of instrument to measure difficulties of life in patients with ulcerative colitis. *The Ochanomizu Medical Journal* 48(2): 71-76., 2000 (in Japanese)
 26. Aoki H, Sakai E. Proposal of a measurement scale to evaluate difficulties of daily life in patients after surgery of oraltumor. *The Ochanomizu Medical Journal* 48(2): 63-70., 2000.(in Japanese)
 27. Koyama C, Kawa M, Kasahara Y. Progression of disease and process of psychological change of terminally ill patients with cancer, An analysis of medical and nursing charts. *Japanese Journal of Clinical Thanatology* 5(2): 85-91., 2000. (in Japanese)
 28. Koike T, Kazuma K. Recognition by nurses of the need for outpatient consultation and guidance, and challenge for the future. *J Jpan Acad Nurs Admin Policies* 4(1): 23-32., 2000. (in Japanese)
 29. Kazuma K, Yokomura T, Hara M, Aoki H, Okamoto N. Practice and evaluation of primary nursing in outpatient department. *J Jpan Acad Nurs Admin Policies* 4(1): 34-38., 2000. (in Japanese)
 30. Kato M, Hashimoto S, Miyashita M, Hayashi M, Nakamura Y, Ojima T, Matsumura Y, Fukutomi K. The transition of elderly welfare policy differences in prefectures and municipalities. *Journal of Health and Welfare Statistics* 47(4): 8-13., 2000. (in Japanese)
 31. Ushikubo M, Kazuma K. Research and challenge for the care of chronically ill people. *J J Nurs Res* 33: 203-211., 2000. (in Japanese)
 32. Takeda Y, Kazuma K. Family cancer and nursing. *Gastroenterolog Surg Nurs* 15: 205-211., 2000. (in Japanese)

33. Sato M. How to assessment defecation dysfunction and how to approach these patients. *The Japanese Journal of Nursing Art* 46(11): 26-32., 2000. (in Japanese)
34. Kawa M. The nursing role in palliative care. In: Higashiha M and Kondo M (eds.). *Palliative Care. Nursing QOL Books*. Igakushoin. Tokyo 117-128., 2000. (in Japanese)
35. Kazuma K. Risk counseling for familial cancer. *Journal of Family Tumor* 1(1): 9-15., 2001. (in Japanese)
36. Hayakawa E, Ushikubo M, Kawamura S, Kazuma K, Yuasa S, Takagi K. Analysis of the activity of the medical counseling services for intractable illnesses(Nanbyo) of the Tokyo medical association. *Jpn J Prim Care* 24(3): 189-196., 2001. (in Japanese)
37. Okano Y, Okamura H, Watanabe T, Narabayashi M, Katsumata N, Ando M, Adachi I, Kazuma K, Akechi T, Uchitomi Y. Mental adjustment to first recurrence and correlated factors in patients with breast cancer. *Breast Cancer Res Treat* 67(3): 255-262., 2001.
38. Murakami Y, Gondo N, Okamura H, Akechi T, Uchitomi Y. Guilt from negative genetic test findings. *Am J Psychiatry* 158(11): 1929., 2001.
39. Kazuma K. The relationship between fatigue and nutritional status in patients with Rheumatoid Arthritis. *The international conference*. Tokyo University, Oita University & S.N.U. Seoul: 109-112., 2001.
40. Agata T, Kawa M. Research on medicine and nursing. In Agata T. (ed.), *PubMed, Impact Factor for EBM*. Chugaiigakusha, Tokyo:1-20., 2001. (in Japanese)
41. Takeda Y, Kazuma K. Practice of genetic nursing; cancer. In Andou H. et al (eds.), *Genetic Nursing*. Ishiyaku Publishing Co., 108-118., 2001. (in Japanese)
42. Imamura Y. Hospice home care. *Kango* 53(10): 98-102., 2001. (in Japanese)
43. Takeda Y. Need of the support system for family members with hereditary cancer. *The Japanese Journal of Nursing* 65(10): 948-951., 2001. (in Japanese)
44. Aoki H, Ohta K, Kazuma K. The current status and problems of nursing for outpatients department of oral surgery of dental university hospitals in Japan. *The Journal of the Stomatological Society, Japan* 69(2): 9-14., 2002. (in Japanese)
45. Emoto A. A study on the long-term effects and contributing factors of pelvic floor muscle exercise in women with stress urinary incontinence. *The Ochanomizu Medical Journal* 50(1): 19-34., 2002.(in Japanese)
46. Watanuki E. Nursing staff's understanding of their liability in nursing practice. *Jpn Nurs Res* 25(2): 61-69., 2002. (in Japanese)
47. Sato N, Kato A, Sugimura H. Physician's level of knowledge regarding genetic counseling in the field of clinical genetics. *Journal of Familial Tumor* 2(1): 20-25., 2002. (in Japanese)
48. Imamura Y, Kawa M, Kayama M, Mizuno M, Otsuka M, Murata H. Conceptual structure on spirituality in end-of-life patients with cancer. *The Japanese Journal of Hospice and Palliative Care* 12(5): 425-434., 2002. (in Japanese)
49. Kawa M, Koyama C, Imamura Y, Miyashita M, Ashiya T, Kasahara Y. Physical state and psychological expression of terminally ill patients with cancer in a palliative care unit. *The Japanese Journal of Clinical Thanatology* 7(1)., 2002. (in press)
50. Furukawa F, Kazuma K, Kawa M, Miyashita M, Niuro K, Kusukawa T, Kojima M. Effects of an off-site walking program on energy expenditure, serum lipids, and glucose metabolism in middle-aged women. *Biological Research for Nursing* 4(3)., 2002. (in press)

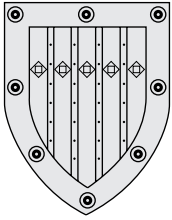

Department of Family Nursing

Outline and Research Objectives

The Department of Family Nursing was established in April 1992 and was started at October 1992 when Dr.Sugishita had a position of Professor of Family Nursing. Currently, it has four faculty members; one professor, one associate professor and two associates.

Our department is based on new concept which combines together the following four nursing fields: maternal-child nursing, pediatric nursing, gerontological nursing and family nursing.

Our department provides lectures, clinical practicums and fieldwork on the four nursing fields to the undergraduate students of School of Health Sciences and Nursing. Our department also gives two required lectures, that is, "clinical immunology " and "laboratory methods in health science" to the undergraduate students of our school.

We also have responsibilities to give special lectures, advanced seminar and laboratory and/or field work on family nursing to the postgraduate (master's and doctoral) students.

Our research field concerns the development of methodology to improve nursing skills and techniques, and the development of physical, psychological and interactive assessment procedures for patients and families in our field.

Faculties and Students

Professor and Chair	Chieko Sugishita R.N., Ph.D. 1992~
Associate Professors	Kiyoko Kamibeppu R.N., Ph.D.
Associate	2
Postdoctoral Fellow	5
Graduate student	10
Research student.....	15
Secretary	2

Past Research and Major Accomplishments

Topics of our past research projects were as follows.

- ①Control of maternal-child transmission of micro-organism,
- ②Control of body fluid circulation in women supported with physical compression,
- ③Evaluation of antibody development after immunization in children and analysis of immune system,
- ④Environment/food factors of allergic diseases among children,
- ⑤Recent anxiety coping strategies in Japan,
- ⑥Psychological factors of the family caregiving for the frail elderly,
- ⑦Development of new devices for evaluating autonomic nervous activities of the frail elderly,
- ⑧Development of Japanese version of family functioning survey.

Major accomplishments were as follows.

Number indicates the number of research project.

- ①We examined the samples from neonates, their mothers, medical staffs and environment in a maternal ward to isolate some bacteria in order to demonstrate the route of transmission to neonates. Some of the neonates had the same bacteria as their mothers, medical staffs and environment at the point of discharge. Therefore, Several bacteria could have been transmitted to the neonates from their mothers, medical staffs and/or environment in hospital.
Our data also showed that mamma trouble did not decrease even if they use nipple wiped with sterilized cotton. It seemed that hand washing before breastfeeding was more important.
- ②The physical compression with stocking was effective to control the blood pressure decrease when supine position was changed to standing up position, especially in the elderly. It was suggested the stocking might prevent the orthostatic hypotension in the elderly.
- ③Vaccine-induced immunity of measles, mumps, rubella and chickenpox at one to three years of age continued until nine years of age. But the level of immunity was lower than naturally aquired immunity.

- ④ This study showed that incidence of atopic children was decreased by age, but any risk factors could not be found in atopic children compared with non-atopic children.
- ⑧ We developed Japanese version of Feetham Family Functioning Survey (FFFS) which enables to evaluate the family functions for young families with children.

Current Research

Current research projects include four fields, that is, maternal-child nursing, pediatric nursing, gerontological nursing and family nursing.

Topics of our current research projects are as follows: ① Control of hospital infection such as transmission of bacteria including MRSA between mothers and their babies, ② Exploring the new nursing care model for the children with disabled and/or chronic illness in the community, ③ Interaction between nursing home residents and their families, ④ Nurses' interests in family care for critical patients, ⑤ Assessment of autonomic nervous activity in the elderly with chronic illness in hospital, ⑥ Incidence of adverse reactions associated with Japanese-style medical acupuncture for the elderly, ⑦ Follow up study of physical, mental and social activities of patients with dementia.

Future Prospects

Since two more Departments, 'Midwifery Nursing and Women's Health' and 'Gerontological Nursing', will be established in 2002 and 2003 respectively, our department will be responsible mainly for Family Nursing and Pediatric Nursing.

Concept of family nursing was introduced to Japan country only ten years ago, and The Japanese Association for Research in Family Nursing was founded by our department in 1994. Our department will explore the establishment of the theory in family nursing collaborating with its research, practice and education.

Education and research of pediatric nursing are also involved in our activities. We intend to research new fields of pediatric nursing in the viewpoints of child rights, good prognoses of severe illness, birth of children with diversified origins on the basis of the progress of reproduction technology, and well-being for all of the families.

Research Grants (within 5 years)

- 1, Chieko Sugishita, Naohiro Hohashi: Infection control among nursing mothers and neonates, and related quality of nursing care -According to analyses of bacteria including MRSA in a maternity clinic-, Grants-in-Aid for Scientific Research (B)(2), 1998-1999, The Ministry of Education, Culture, Sport and Science, ¥10,200,000
- 2, Chieko Sugishita, Noriko Yamamoto, Mamoru Kumada: Development of passive of leg cycle exercise for the elderly to improve the walking rhythm and enhance the autonomic nervous activity. Grants-in-Aid for Scientific Research (B)(2), 1999-2000, The Ministry of Education, Culture, Sport and Science, ¥6,400,000
- 3, Chieko Sugishita, Kunihiko Hayashi, Naohiro Hohashi, Kunie Mituhashi: Development of two dimensional scale in order to assess the family system and care ability, Grants-in-Aid for Exploratory Research, 1999-2000, The Ministry of Education, Culture, Sport and Science, ¥2,100,000
- 4, Hiroko Torii, Hideko Mori, Chieko Sugishita: Study on nurses' views on family and family nursing, Grants-in-Aid for Exploratory Research, 1999-2000, The Ministry of Education, Culture, Sport and Science, ¥800,000
- 5, Chieko Sugishita, Kiyoko Kamibeppu, Keiko Murata, Naohiro Hohashi, Hiroko Torii, Makiko Owaki, Kunihiko Hayashi: Development of nursing practice model for the children with chronic illness or/and disabilities and their families in community. Grants-in-Aid for Scientific Research (B)(1), 2001-2003, The Japan Society for the Promotion of Science, ¥12,100,000

Select Publications

1. Sugishita C, O'shea S, Best J, and Banatvala J E. Rubella serology by solid-phase radioimmunoassay. its potential for screening programmes. *Clin. Exp. Immunol* 31(1), 50-54, 1978.
2. Shishido A, Sugishita C, Takahashi C, Sakata H, Hirayama M, and Kimura M. A ten-year follow-up study on measles vaccination in Japan: Evaluation of the efficacy analyzed on a computer system. *Japanese Journal of Medical Science & Biology* 31(4), 339-356, 1978.
3. Kono R, M. Hirayama, Sugishita C, and Miyamura K. Epidemiology of rubella and congenital rubella infection in Japan. *Reviews of Infectious Diseases, Supplement 1*, 56-63, 1985.
4. Maekawa K, Nozaki H, Fukushima K, Sugishita C, and Kuriya N. Clinical analysis of measles, mumps and rubella vaccine meningitis? Comparative study of mumps, mumps meningitis and MMR meningitis?. *Jikeikai Medical Journal* 38(4), 361-368, 1991.
5. Iida Y, Sugishita C, Matsuura K, and Torii H. English education in colleges of allied health sciences. *Bulletin of Tokyo Metropolitan College of Allied Medical Sciences* 7 97-102, 1994.
6. Nagase H and C. Sugishita. Mother's anxiety related to their child rearing on telephone consultation. Analysis of statement about the in health center-. *J Child Health* 53, 668-76, 1994. (in Japanese)
7. Sugishita C, Tezuka K, Hohashi N and Higurashi M. Effects of medical compression stockings on lower leg girth in healthy women. *Jpn J Maternal Health* 35, 50-53, 1994. (in Japanese)
8. Hohashi N, Etoh T, Kurahashi T, Tejima R and Sugishita C. Seroepidemiology of primary school children in the third grade for naturally acquired or vaccine induced immunity of measles, mumps, rubella, and chickenpox determined by presence of IgG antibody. *Infection and Immunity in Childhood* 6, 251-4, 1994. (in Japanese)
9. Sugishita C, Mori H, Nagase H, Tezuka K, Kurahashi T and Hirayama M. Immunization of communicable disease and morbidity rate in handicapped children and young adults. *J Child Health* 53, 842-8, 1994. (in Japanese)
10. Tamura T, Naoko H, Nagase H, Morokata T, Igarashi O, Oshimi Y, Miyazaki S and Nariuchi H. Early activation signal transduction pathways of Th1 and Th2 cell clones stimulated with anti-CD3. *J. Immunol* 24, 4692-4701, 1994.
11. Yoshimoto T, Nagase H, Nakano H, Matsuzawa A and Nariuchi H. AV β 8.2-specific superantigen from exogenous mouse mammary tumor virus carried by FM mice. *Eur. J. Immunol.* 24, 1612-1619, 1994.
12. Sugishita C, H Yonezawa, N Hohashi, Y Iida, F Komoda, T Iwata and H. Hayakawa. The significance of guidance for mothers of allergic children with regard to dietary restrictions. *Proceeding of The XVth World Conference of the International Union for Health Promotion and Education.* 312-315, 1995.
13. Sugishita C, Morotomi C, and Murata I, etc. Evaluation of PHA/RIA antibody responses to CHO cell derived HB vaccine compared with yeast and plasma derived HB vaccines. *Clinical Virology* 23, 231-236, 1995.
14. Sato Y, Sugishita C, Kataoka Y. The effect of walking on blood pressure changes and accelerated plethysmogram (APG) in middle aged and elderly people with hypertension. *Jpn J Res Fm N* 2, 28-35, 1996.
15. Hohashi N, Hayashi T, Fusaki N, Takeuchi M, Higurashi M, et al. The protein tyrosine kinase Fyn activates transcription from the HIV promoter via activation of NF K b-like DNA-binding proteins. *Int. Immunol* 7, 1851-1859, 1995.
16. Tezuka K, Sato R, Igarashi T and Sugishita C. The effect of pneumatic massage on the leg circumferences of healthy women. *Clinical Report* 30, 203-209, 1996.
17. Tezuka K, Sugishita C, Kuwaki T, Higurashi M and Kumada M. Effects of compression stockings on blood pressure and its orthostatic change in female subjects. *Pathophysiology* 4, 81-86, 1997.
18. Iwata T, Hayakawa H, Komoda F, Koseki M, Miyakawa T, Sakurayama T, Yamasaki K, Honjou M, Hirakawa N, Inoue K, Hohashi N, and Sugishita C. Prospective study of atopic status in infants of the cohort in Tokyo, Japan. *Allergology International* 46, 221-225, 1997.
19. Miki A, Haratani T, Sugishita C, Kawakami N, Araki S, and Kawamura N. The effects of job stressors on depression and job satisfaction among hospital nurses in Japan. *Proceedings 15th Asia Conference On Occupational Health* 226-231, 1997.
20. Yoshidome A, C. Sugishita. A study on the relationship between mamma trouble and practice of nipple wiping with sterilized cotton. *Japanese Journal of Maternal Health* 38, 350-354, 1997. (in Japanese)
21. Tsuchiya H, Kusaka S, Hohashi N, Sugishita C. The decrease of the seroprevalence of antibodies against herpes simplex virus and cytomegalovirus among students of nursing college and consideration of their lifestyles and rearing environments. *Infection and Immunity in Childhood* 9, 95-102, 1997. (in Japanese)
22. Page J, Lim H, Lynett L-Y, Heller R, Fukuhara H, Ban S, Yamamoto N, and Kurokawa K. Critical appraisal workshop in Japan: a short term evaluation. *Education for Health.* 10, 371-377, 1997.
23. Yamamoto N and Wallhagen M I. The continuation of family caregiving in Japan. *Journal of Health and Social Behavior.* 38, 164-175, 1997.
24. Nagase H, Wang C, Yoshimoto T, Sugishita C, and Shiroishi T, Matuzawa A and Nariuchi H. Analysis of novel mutant mice secreting soluble CD4 without expression of membranebound CD4. *Eur. J. Immunol* 28, 403-412, 1998.

25. Naito N, Hashimoto Y, Sugishita C. Development of the childcaring perspective scale for mothers with children aged three or younger(CPS-M 97): -Validity and Reliability of the CPS M 97-. *Journal of Japan Academy of Nursing Science* 18, 1-9, 1998. (in Japanese)
26. Torii H and Sugishita C. Behavioral problems of the child when his/her mother is staying with his/her hospitalized sibling. *Japanese Journal of Research in Family Nursing* 4, 18-23, 1998. (in Japanese)
27. Matsui N, Ju K, Kumada M and Sugishita C. The effect of water exercise with a jet on the frail elderly. *The Autonomic Nervous System* 35, 419-423, 1998. (in Japanese)
28. Yamamoto N and Sugishita C. Utilization patters of care assistance by family caregivers of visitors to a clinic for the elderly. *Japanese Journal of Gerontology* 19, 129-139, 1998.
29. Yoshinaga, A., and Horibe, H. Serum lipid concentrations in Japanese children: A synthesis of 27 studies. *CVD Prevention*. 1: 55-70, 1998.
30. Yamamoto N, and Wallhagen M I. Service use by family caregivers in Japan. *Social Science and Medicine*, 47, 677-691, 1998.
31. Sugishita C. Development of family nursing in Japan-persent and future perspectives. *Journal of Family Nursing* 5(2), 239-244, 1999.
32. Matsui N, Ju K, Sugishita C and Kumada M. Assessment of baroreceptor reflex sensitivity during passive leg cycle exercise using bivariate autoregressive model. *Proceedings of the IFMBE/IMIA 3rd International Workshop on Biosignal Interpretation*. 91-94, 1999.
33. Omine F, Hamamoto I, Odo S, Miyagi M, Sunagawa Y, Sugishita C. A Study of the Effect of Peer Education on Student Sexual Awareness. *Journal of Japan Academy of Nursing Science* 19(3), 64-73, 1999. (in Japanese)
34. Nakatani Y, Hohashi N and Sugishita C. Changes of hemodynamics due to white noise stress according to the extents of obesity. *The Japanese Journal of Health and Human Ecology* 65, 208-218, 1999. (in Japanese)
35. Hohashi N, Matsumoto K and Sugishita C. National survey of actual conditions related to MRSA conducted through home-visit nursing care station-Focusing on incidence of MRSA and problems related to home care-. *Japanese Journal of Research in Family Nursing* 4, 119-124, 1999. (in Japanese)
36. Mori N, Ito T, Tsushima R, Hhashi N, Hiramatu K and, Sugishita C. Bacteriological and molecular epidemiological analysis of methicillin-resistant staphylococcus aureus isolated in a maternity hospital. *Environmental Infections* 14, 296-302, 1999. (in Japanese)
37. Yamamoto-Mitani N, and Sugishita C. Discharge education for neurology patients and their family: Comparison between the recognition of nurses, patients, and their family. *Japanese Journal of Research in Family Nursing* 5(2), 4-18, 1999. (in Japanese)
38. Yamamoto N M, Tamura M, Deguchi Y, Ito K and Sugishita C. The attitude of Japanese family caregivers toward the elderly with dementia. *International Journal of Nursing Sutudies* 37, 415-422, 2000.
39. Mori N, Hitomi S, Okuzumi K, Yoneyama A, Sugishita C, and Kimura S; Susceptibility to vancomycin of methicillin-resistant *staphylococcus aureus* isolated in a university hospital in Japan. *J. J. A. Inf. D.* 74(11), 966-972, 2000.
40. Yamamoto N M, Abe T, Yamada Y, Yamazato C, Amemiya H, Sugishita C and Kamata K. Reliability and validity of Japanese quality of life scale for the elderly with dementia. *Nursing and Health Sciences* 2(2), 69-78, 2000.
41. Matsui N, Ju K, Ohmori N, Sugishita C and Kumada M. A new device for evaluating autonomic nervous activity of cardiovascular system. *Biomedical Sciences Instrumentation* 36, 87-92, 2000.
42. Maeda M, Hohashi N, Sugishita C. Survey of the family accompaniment of hospitalized children. *Japanese Journal Research in Family Nursing* 5, 94-100, 2000. (in Japanese)
43. Kudo Y and Sugishita C. A Study of infection control among HPN patients. *Infection Control* 179-182, 2000. (in Japanese)
44. Yamamoto-Mitani N and C. Sugishita. The effectiveness of nurses' discharge education and post-discharge patient problem evaluation. *Japanese Journal of Nursing Science* 20(2), 21-28, 2000. (in Japanese)
45. Hohashi N, Maeda M and Sugishita C. Development of the Japanese-language Feetham Family Functioning Survey(FFFS) and evaluation of its effectiveness. *Japanese Journal of Research in Family Nursing* 6, 2-10, 2000. (in Japanese)
46. Yamashita H, Tsukayama H, Hori N, Kimura T and Tanno Y. Incidence of adverse reactions associated with acupuncture. *J Altern Complement Med.* 6(4), 345-350, 2000.
47. Kobayashi N. Formal service utilization of the frail elderly at home during the last six months of life. *Nursing and Health Sciences* 2, 201-204, 2000.
48. H Yamashita, H Tsukayama, and Sugishita C; Local adverse reactions commonly seen in Japanese-style medical acupuncture practice. *Clinical Acupuncture and Oriental Medicine* 2, 132-137, 2001.
49. Yamashita H, Tsukayama H, White A R, Tanno Y, Sugishita C, and Ernst E. Systematic review of adverse events following acupuncture: the Japanese literature. *Complementary Therapies in Medicine*, 9, 98-104, 2001.
50. Yamamoto-Mitani N, Sugishita C, Ishigaki K, Hasegawa K, MaekawaN, Kuniyoshi M, and Hayashi K. Development of instruments to measure appraisal of care among Japanese family caregivers of the elderly.

erly, *Scholarly Inquiry for Nursing Practice: An International Journal*, 15, 113-135, 2001.

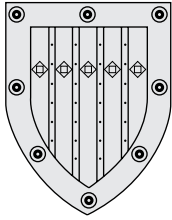

Department of Community Health Nursing

Outline and Research Objectives

Department of Community Health Nursing (CHN) was established in June 1992 with the appointment of Dr. Katsuko Kanagawa as the first professor of the department. In May 1993, Dr. Sachiyo Murashima joined as associate professor and took charge as professor after Dr. Kanagawa's retirement.

During ten years since the department's inauguration, 12 students have succeeded in gaining the degree of Doctor of Health Sciences; 19 the degree of Master of Health Sciences, and in the undergraduate course 20 students elected to write theses in community health nursing.

In order to enhance the practice of nursing and public health, the department strives to undertake research for improvement of quality of life (QOL) of people in various community settings by focusing on:

1. Developing a comprehensive health care system for community care through public health nursing leadership;
2. Intervention projects to demonstrate efficacy of new initiatives directed at improvement of QOL of bedridden, frail and demented elderly;
3. Preventive programs to improve clinical practice in home (e.g. falls) and to reform policy directions;
4. Undertaking commissioned research with government and non-governmental organizations driven by needs and resources of individuals, families, targeted population groups and organizations in order to measure cost-effectiveness and quality of care;
5. Developing models for community nursing practice to provide efficient care in partnership with other professionals, families and communities.

The major studies undertaken by the members of the CHN department can be classified as following;

Directed at	Descriptive studies	Intervention studies
Individuals	<ul style="list-style-type: none"> • Influencing factors of social rehabilitation among former patients with Hansen's disease • Meaning of health among cancer patients • Home visiting for schizophrenic patients 	<ul style="list-style-type: none"> • Prevention for deterioration of ADL among bedridden elders • Effectiveness of reminiscence for the demented elderly (RCT) • Effectiveness of early discharge planning(RCT)
Families	<ul style="list-style-type: none"> • Attitude and interaction of grand children to the demented elders at home • Care of families of children with chronic disease 	<ul style="list-style-type: none"> • Effectiveness of improved home visit program for newborn babies
Aggregates	<ul style="list-style-type: none"> • Characteristics of professional support to family groups of psychiatric patients • Meaning and strategy of rural women for maintaining both agriculture and care-giving 	<ul style="list-style-type: none"> • Effectiveness of improving support program to family groups of psychiatric patients (RCT)
Home health service and a community working	<ul style="list-style-type: none"> • Community diagnosis and networking • Comparison between two types of around-the-clock in-home care systems : a single type of home help service and a combination type with nursing 	<ul style="list-style-type: none"> • Development and evaluation of around-the-clock in-home care system

Faculty and Students

Professor and Chair	Sachiyo Murashima, D.Hlth.Sc., R.N., P.H.N. (2001~)
Associate Professor	Noriko Nishikido, D.Hlth.Sc., R.N., P.H.N.
Associates	2
Graduate Students	11 (7 in Master course; 4 in Doctoral course)
Research Students.....	2
Secretaries	3

Past Research and Major Accomplishments

Research Areas of Community Health Nursing

Community health nursing research has been considered from three perspectives; 'nursing *in* the community', 'nursing *of* the community' and 'nursing *into* the community.' A majority of studies have focused on continuity of care and empowering people by strengthening their potentiality through creating care systems.

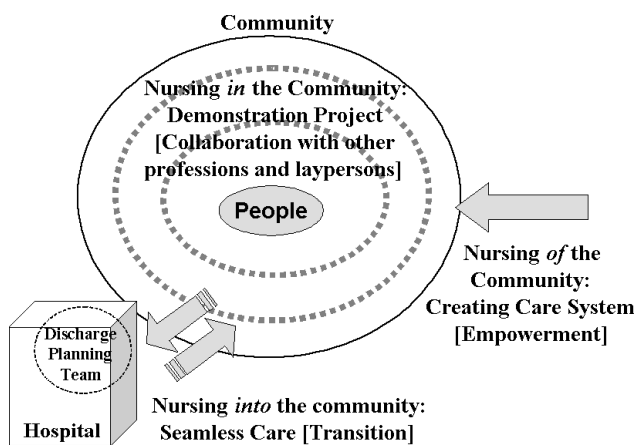

Figure. Community Health Nursing Research: Focal Areas

1. 'Nursing in the community'

'Nursing in the community' means offering nursing services or health promoting activities to people in the community in collaboration with other professionals and/or lay people. It is operationalized by developing and testing a new programs to meet needs of individuals or aggregates.

In 1993, when I was transferred to the University of Tokyo, care burden for the elderly was a topical issue in Japan. Following favorable reports of night-time home helpers' visiting service, a need to add visiting nurse service was strongly solicited. A study testing the efficacy of model programs involving four visiting nurse stations providing around-the-clock nursing care (ACC) commenced with assistance from the Ministry of Health and Welfare in 1994.

Based on the needs assessment for ACC, an intervention of visiting nursing care early in the morning and evening was provided; and simultaneous evaluation was carried out before, during and after 3 months. Major findings indicated positive effects related to stabilized medical status, reduced stress, thereby reduced complications such as decubitus (see article number 22).

The results also impacted on policy change: in 1996 the fees for ACC visiting nurses, which enabled the night time visits by nurses, were included in the national health insurance program. The combination type of nursing and home help service functioned more effectively than a single type of home help service (see article number 34).

2. Nursing of the community

Research for 'nursing of the community' means creating care systems in the community for providing effective care of individuals to enhance their capacity. A study depicting the role of public health nurses in enabling the community to establish its own care system to solve problems (see article number 25) was in a rural town M with a focus on ACC system.

The major purpose of this study was to test the

feasibility of ACC visiting nurse service as desired by the community, to measure its effectiveness and eventually to develop a policy for providing this service within the local government health plan. The intervention included establishing the need and acceptance of service, involving residents and other health workers, resulting in whole community handling conflicting concepts such as 'Sekentei', a kind of socio-cultural norm (see articles number 31, 43, and 48).

Intervention and control population were used for comparison to measure the effectiveness of around-the-clock visiting nurse service. The outcomes of ACC by nurses and home-helpers indicated lower rates of institutionalization and reduced waiting lists in the study town, compared with the control town, although control town rates of institutionalization did not differ from all Japan rates (see article number 47).

3. Nursing into the community: Creating seamless care

The third area, 'nursing into the community', refers to developing models to assist patients and families when patients return home through multidisciplinary and collaborative discharge planning in hospitals in order to implement seamless care. To determine the effectiveness of newly established discharge planning service, several studies were conducted, including the characteristics of patients referred for discharge planning and of those identified being at risk (see article number 35).

A quasi-experimental trial reexamined the effectiveness of early discharge planning for at-risk hospitalized elders. The findings indicated decreased anxiety in patients and caregivers, and effectiveness in terms of prevention of prolonged hospital stay (see article number 36).

A book 'Discharge Planning: A Challenge at the Tokyo University Hospital' was published in 2002, as one of scholarly outcomes of this research activity.

Current Research Projects

Current research of the community health nursing department is dedicated to further exploration of ways to promote health and continuation of projects in the preceding years. To list a few are;

1. Support program for the lonely elderly, fall prevention program, and demonstration projects such as developing check list of unilateral spatial neglect and related disorders amongst cerebro-vascular patients in community settings.
2. Review and expansion of long-term care in a rural town, Town M, for the evaluation Long-Term Care Insurance.
3. Seamless care between hospital and community 1) Development and test of usefulness of check list

for potential high-risk patients for referral of discharge planning support team; 2) Investigation of daily life problems immediately after discharge.

Future Plan

Since numbers of elderly in Japan are rapidly increasing and family support is dwindling, the department endeavors to take a lead role in research related to establishing basic home care programs that are efficient, acceptable by funding bodies (e.g. government) and adaptable by the local communities. Therefore,

1. Faculty and graduate students of department are dedicated to developing community interventions specifically for care of demented and bed-ridden elders.
2. Health promotion intervention studies to strengthen community competence and lines of resistance through programs, such as: 1) developing volunteer networking which offers day care programs to prevent elders from deterioration, and bed-ridden or demented; 2) support programs for 75 years and older by offering preventive home visiting 2-3 times a year; 3) strengthen and support community health nurses in developing skills and sustainable capacity-building developmental approaches towards community partnerships and activities in the community.

Research Grants (selected 5)

Sachiyo Murashima (P.I.), Katsuko Kanagawa, Hiromi Kawagoe.

A study on organization and specification of functions of home care nursing: From the viewpoint of 24-hour care plan.

Grant-in-Aid for Scientific Research (B) by the Ministry of Education and Culture in 1998-1999; ¥12,400,000.

Sachiyo Murashima (P.I.), Shuhei Ryu, Masako Yamada, Yutaka Tagami, Hiromi Watanabe, Naomi Sumi, Naoko Takeuchi.

A study on promoting the model project of a combination type of nursing and home-help service.

Research Grant for Welfare of the Elderly by the Ministry of Health, Labour and Welfare in 1999; ¥5,000,000.

Sachiyo Murashima (P.I.), Tomoe Nogawa.

A research on promotion of well-being of the elderly by public health nurses' activities.

Research Grant for Welfare of the Elderly by the Ministry of Health, Labour and Welfare: Research Project for Supporting Independent and Healthy Elders in 2000; ¥10,000,000.

Hidetoshi Endo (P.I.), Sachiyo Murashima, Satoko Nagata.

A study on effectiveness of the support system of discharge planning for hospitalized elders in special functioning hospitals.

Research Grant for Longevity Sciences from the Ministry of Health, Labour and Welfare in 2000-2002; ¥1,500,000 in each year.

Sachiyo Murashima (P.I.), Ryutaro Takahashi, Satoko Nagata, Megumi Haruna.

Effectiveness of the program for discharge planning for elderly in-patients.

Grant-in-Aid for Scientific Research (B) by the Ministry of Education and Culture in 2001-2002; ¥9,200,000.

Select Publications

*: copy attached.

1. Murashima S and Iida S. A study on health behavior and life style of primary school children: The difference between urban and rural communities, fifteen years ago and now. *Research Journal of School Health* 23(11), 531-539, 1981. (in Japanese)
2. Murashima S, Ryu S, Tanaka T and Tomari T. A study on trends of the regional variations of physical standards in Japanese schoolchildren. *Research Journal of School Health* 24(2), 89-97, 1982. (in Japanese)
3. Murashima S. A case study on family life of young women with Diabetes Mellitus: How much can their husbands, relatives, neighborhood and children understand their situations? *Journal of Japan Academy of Nursing Science* 2(1), 39-47, 1982. (in Japanese)
4. Murashima S, Iida S, Ishii Y, Fujita A, Matsushita K and Watanabe H. Health condition and home care of the aged with 75 years and over: Regional differences between urban and suburban areas. *Bulletin of St. Luke's College of Nursing* 15, 28-43, 1989. (in Japanese)
5. Murashima S, Iida S, Ishii Y, Matsushita K, Fujimura M, Sanuki J, Hanazawa K, Watanabe H and Sakurai N. Health conditions and home care of the frail elders with 75 years and over: Regional differences between urban and suburban areas. *Bulletin of St. Luke's College of Nursing* 16, 60-69, 1990. (in Japanese)
6. Yoshio K, Murashima S and Iida S. A study on changes of DM patients' life style and the affecting factors. *Journal of Japan Academy of Nursing Science* 10(1), 24-36, 1990. (in Japanese)
7. Fukanoki T, Murashima S and Iida S. Analyses of factors affecting home oxygen therapy (HOT) patients' Quality of Life: Focusing on their life satisfaction. *Journal of Japan Academy of Nursing Science* 11(1), 9-21, 1991. (in Japanese)
8. Fukaya A, Murashima S and Iida S. Analyses of factors affecting the change in ADL of post-infarct hemiplegics elders living at home: Focusing on the daily life style of the patients and their families.

- Journal of Japan Academy of Nursing Science 11(2), 44-54, 1991. (in Japanese)
9. Murashima S, Iida S, Matsushita K, Sakurai S and Naruki H. Building a care system for frail elderly in the community. Annual Report: St. Luke's College of Nursing, WHO Collaborating Center for Nursing and Midwifery Development in PHC 1990/1, 48-54, 1992.
 10. Mizuno T, Murashima S and Iida S. Analyses on care burden and cognitive discrepancies of care role between frail elders and their care-givers. Journal of Japan Academy of Nursing Science 12(2), 17-29, 1992. (in Japanese)
 11. Murashima S, Satoh R, Naruki H, Kurebayashi M and Iida S. Issues in mobilizing the bedridden elderly at home. Annual Report: St. Luke's College of Nursing, WHO Collaborating Center for Nursing and Midwifery Development in PHC 1991/2, 8-20, 1993.
 12. Nishio J, Murashima S and Iida S. Health behavior model based on analysis of factors affecting alcohol behavior of company employees. Japanese Journal of Public Health 41(7), 607-617, 1994. (in Japanese)
 13. Murashima S. Limitation of care-giving to the elders by the families and the conditions for the society to take care of the elders. Research Journal of Care and Welfare 2(1), 23-30, 1995. (in Japanese)
 14. Ota K, Tamura M, Sei M, Koyama M, Hishinuma M and Murashima S. The content and its teaching method of nursing for elderly in Baccalaureate Program. Bulletin of St. Luke's College of Nursing 21, 34-40, 1995. (in Japanese)
 15. Murashima S, Murakami K, Kadokawa T, Sasaki M, Naruki H, Kawakami H, Arai H, Iwanaga T and Iwamuro S. Strategies of public health nurses to practice in rural areas and urban areas. Japanese Journal of Public Health Nurses 51, 91-96, 1995. (in Japanese)
 16. Murashima S, Yamada M, Tagami Y, Satoh M, Uchida E, Miyazaki W, Kawagoe H, Hoshi T, Ooura H, Horii T, Nakayama I and Yamazaki M. Facts through the project of around-the-clock nursing and care provided by visiting nurse service stations. Japanese Journal of Home Care Nursing 1(2), 83-92, 1996. (in Japanese)
 17. Murashima S, Kim J and Fukui S. Outcomes in home care. Japanese Journal of Nursing Research 30(5), 351-363, 1997. (in Japanese)
 18. Murashima S, Fukui S and Kim J. Several kinds of recording formats for home care developed on the basis of outcome. Japanese Journal of Nursing Research 30(5), 47-63, 1997. (in Japanese)
 19. Okada M, Murashima S and Asahara K. A study on competencies used by public health nurses in creating new health care systems in the community. Japanese Journal of Public Health 44(4), 309-321, 1997. (in Japanese)
 20. Murashima S and Yamada M. Support for home care in the community: Principles of providing home help and nursing care. Health Sciences 14(1), 6-11, 1998. (in Japanese)
 21. Murashima S. Role and issues of visiting nurse service in the aging society: For effective home care. Japanese Journal of Gerontological Sociology 20(1), 16-24, 1998. (in Japanese)
 - 22*. Murashima S, Zerwekh JV, Yamada M and Tagami Y. Around-the-clock nursing care for the elderly in Japan. Image: Journal of Nursing Scholarship 30(1), 37-41, 1998.
 23. Konishi K, Murashima S and Kanagawa K. A study on stress-coping in the stroke rehabilitation process: A qualitative analysis on problems recognized by patients. Japanese Journal of Home Care 1(1), 56-66, 1998. (in Japanese)
 24. Okamoto E, Murashima S and Saito E. The significance of day care service for elders with dementia and their caregivers: What is the difference between the day with day care service and the day with no service? Japanese Journal of Public Health 45(12), 1152-1161, 1998. (in Japanese)
 - 25*. Murashima S, Hatono Y, Whyte N and Asahara K. Public health nursing in Japan: New opportunities for health promotion. Public Health Nursing 16(2), 133-139, 1999.
 26. Murashima S. Function and role of nurses in around-the-clock in-home care service. Health Care 40(5), 387-392, 1998. (in Japanese)
 27. Murashima S, Ryu S, Asahara K, Yamada M and Tagami Y. A system supporting the elderly at home: Demand and effectiveness of 24 hour home care which includes medical treatment. Geriatric Medicine 36(12), 1789-1795, 1998. (in Japanese)
 28. Yamawaki A and Murashima S. Home care service utilization by severely mentally and physically handicapped persons. Japanese Journal of Public Health 45(6), 499-511, 1998. (in Japanese)
 29. Ito A, Murashima S, Choi J and Horii T. The meaning of the characteristics on the function of night-time nurses' visits: Through the analyses of the users' record of the visiting nurse station which provides around-the-clock in-home care by three shifts of nurses. Journal of Japan Academy of Home Health Care 3(1), 68-77, 1999. (in Japanese)
 30. Murashima S, Saito E, Hattori M, Hagiwara A, Sumi N, Ueno M and Kanagawa K. Study on competencies of community health nurses and introduction of the activity by Dr. Joyce Zerwekh: Focused on home visits and visiting nurse service. The Japanese Journal of Nursing Research 32(1), 3-14, 1999. (in Japanese)
 - 31*. Murashima S, Asahara K, White MC and Ryu S. The meaning of public health nursing: Creating 24 hour care in a community in Japan. Nursing and Health Sciences 1, 83-92, 1999.
 32. Murashima S and Hollaender L. How do the people in Denmark treat with elders with dementia. The Japanese Journal of Occupational Therapy 34(5), 594-597, 2000. (in Japanese)
 33. Murashima S. Evaluation of home care service. Health Care 42(4), 263-269, 1999. (in Japanese)
 - 34*. Takeuchi N, Murashima S and Hattori M. Comparison between two types of around-the-clock

- in-home care systems: A single type of home help service and a combination type of nursing and home help service, focused on the way of collaboration and its influence. *Journal of Japan Academy of Home Health Care* 4(1), 24-30, 2000. (in Japanese)
- 35*. Murashima S, Nagata S, Toba K, Ouchi Y and Sagawa Y. Characteristics of patients referred for discharge planning from a geriatric ward at a national university hospital in Japan: Implications for improving hospital programs. *Nursing and Health Sciences* 2, 153-161, 2000.
- 36*. Sumi N, Murashima S, Toba K and Ouchi Y. The effectiveness of early discharge planning for hospitalized elders who had expected difficulties of discharge: A quasi-experimental trial in a geriatric ward of a highly advanced medical center. *Journal of the Japanese Society on Hospital Administration* 38(1), 29-40, 2001. (in Japanese)
37. Yokoyama A, Murashima S, Nagata S, Yanagisawa A, Wakabayashi K, Tashiro T, Toba K and Ouchi Y. Follow-up study of patients who received discharge planning by a special department in a national university hospital. *Journal of the Japanese Society on Hospital Administration* 38(1), 53-61, 2001. (in Japanese)
38. Kayama M, Zerwekh J, Thornton KA and Murashima S. Japanese expert public health nurses empower clients with schizophrenia living in the community. *Journal of Psychosocial Nursing* 39(2), 40-45, 2001.
39. Toba K, Akishita M, Tanaka S, Kato T, Kawai S, Yamaguchi N, Murashima S, Iguchi A and Sasaki H. Knowledge and utilization on the comprehensive evaluation of functions and of physicians' opinions in Japan: Joint research based on a wide variety of hospitals and facilities in Japan. *Journal of Japan Academy of Geriatric Medicine* 38(2), 139-147, 2001. (in Japanese)
40. Nagata S and Murashima S. Current situation and issues of support program for early discharge. *Health Care* 44(2), 95-99, 2002. (in Japanese)
41. Murashima S, Nagata S and Haruna M. Visiting nurse service: Transition from hospitals to visiting nurse service stations. *The Japanese Journal of Nursing Research* 35 (1), 15-24, 2002. (in Japanese)
42. Kim J and Murashima S. Comparison of the home care system for the elderly in Japan and Korea: Towards an advanced home care system. *Journal of Korean Academy of Nursing* 31(7), 1166-1173, 2001.
- 43*. Asahara K, Momose Y, Murashima S, Okubo N and Magilvy JK. The Relationship of social norms to use of services and caregiver burden in Japan. *Journal of Nursing Scholarship* 33(4), 375-380, 2001.
- 44*. Murashima S, Nagata S, Magilvy JK, Fukui S and Kayama M. Home care nursing in Japan: A challenge for providing good care at home. *Public Health Nursing* 19(2), 94-103, 2002.
45. Asahara K, Momose Y and Murashima S. Family care-giving of the elderly and Long-Term Care Insurance in rural Japan. *International Journal of Nursing Practice* 8, 167-172, 2002.
46. Honda A, Saito E, Kanagawa K and Murashima S. The relation between characteristics and activities of daily living of the elderly living alone. *Japanese Journal of Public Health* 49(8), 795-801, 2002. (in Japanese)
- 47*. Murashima S and Asahara K. The effectiveness of the around-the-clock in-home care system: Did it prevent the institutionalization of frail elderly? *Public Health Nursing* 20(1): 13-24, 2002.
- 48*. Choi J, Murashima S, Hattori M, Horii T, Nagata S and Asahara K. Factors influencing the utilization of visiting nursing and home-help services. *Japanese Journal of Public Health* 49(9), 948-958, 2002. (in Japanese)
49. Murashima S, Yokoyama A, Nagata S and Asahara K. The implementation of the Long-Term Care Insurance in Japan: Focused on the trend of home care. *Home Health Care Management & Practice* 15(6), 2002 (in press).
50. Momose Y, Asahara K and Murashima S. A trial to support family caregivers in the Long-Term Care Insurance: Self-help groups in small communities. *Home Health Care Management & Practice* (in press).

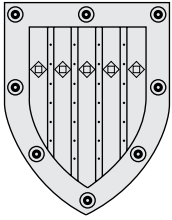

Department of International Community Health

Outline and Research Objectives

The mission of our department is to seek equity and equality in health and health care, and social justice within and across the nations with caring, sharing and compassionate spirit, by the people, with the people and for the people, by means of comprehensive and integrated scientific research and education on health and health care, and social development in collaboration with other related institutes of various disciplines including universities, governmental and non-governmental organizations and private sectors.

Our aim is to bring together the clinical, public health and social science research to address the broad issues of health and health care.

The goals are: 1) to investigate how to change the *status quo* by improving health status of the most vulnerable, the most underprivileged and the poorest of the poor; 2) to undertake research on the influences of 'globalization' and 'free market' system on health and social development; 3) to investigate the mechanisms to reduce inequalities between and within nations on health and development and 4) to develop the mechanisms to link the above three goals with individual research activities described below.

Focusing on the followings:

1. Target diseases or topics: 1) HIV/AIDS (prevention and health care services), 2) Tuberculosis control, 3) Leprosy control, 4) Appropriate treatment and prevention of common diseases and injuries including traffic accidents in Japan and developing countries, 5) Public health aspects of Stroke, 6) Health care services for international migrant workers in Japan, 7) Maternal and Child Health Care (issues on contraceptives excluded).
2. Site/Field: 1) Aral Sea area, 2) Cambodia, 3) Bangladesh, 4) Nepal, 5) Nicaragua and 5) Japan.
3. Research topics are related to Epidemiology, prevention and health care service delivery.

Faculties and Students

Professor and Chair	Susumu Wakai, MD, PhD (1999-)
Lecturer	Nasamine Jimba, MD, PhD
Associate.....	2
Graduate student.....	20
Research student.....	1
Secretary.....	2

- 4) Environmental degradation and people's health: Aral Sea region and elsewhere
- 5) Epidemiology of Stroke and its prevention
- 6) Maternal and child health

In each six research field a concerted effort has been made with the Faculty members and Graduate students to contribute for improving people's health status in developing countries but in developed countries including Japan as well.

Past Research and Major Accomplishments

Please refer to the Select Publications related to Research on International Health including Advocacy papers (number 1 to 31)

Current Research

- 1) Injury prevention in Japan and developing countries
- 2) HIV/AIDS prevention and care among migrant workers living in Japan
- 3) Leprosy and tuberculosis control in Asian countries

Future Prospects

We continue focusing our research efforts on the 6 major research fields described above. We utilize different tools such as Epidemiological, medical. Quantitative and Qualitative research methods. We also need human resource development for continuing such research efforts by mobilizing Graduate students.

Research Grants

Ministry of Education and Science

1. FY 1999 5.5 million Yen: S Wakai, K Pyo. Mechanisms of spondylotic changes of the spine.
2. FY 2001~2002: 3.4 million Yen: S Yanagisawa and S Wakai. Health reform in Cambodia and its effects on people's health seeking behavior
3. FY 2002-2003: 8 million Yen: J Okumura and S Wakai Ministry of Health and Welfare
4. FY 2000-2002: 21.5 million Yen: S Wakai. Health system building for supporting people with HIV/AIDS from overseas.

Select Publications

Research on International Health including Advocacy paper

1. Wakai S: Primary health care projects and social development. *Lancet* 345:1241, 1995
2. Wakai S: Sanctions against Iraq. *Lancet* 347: 200, 1996
3. Wakai S: Access to the Internet. *Science* 271: 1347, 1996
4. Kunii O, Wakai S, Honda T, Tsujimoto K: Role of external medical volunteers after disasters. *Lancet* 347: 1411, 1996
5. Wakai S. Role of neurosurgeons in Japan. *Lancet* 349: 140, 1997
6. Yoshimoto Y, Wakai S: Unruptured intracranial vertebral artery dissection: clinical course and serial radiographic imagings. *Stroke* 28:370-374, 1997
7. Wakai S: Global health care and neurosurgeons. *Neurol Med Chir* 37:483-490, 1997
8. Wakai S: Scourge of Japanese encephalitis in south-western Nepal. *Lancet* 351:759, 1998
9. Wakai S: Health care in Burma. *Lancet* 352: 1230, 1998
10. Wakai S: Surgical treatment for incidentally discovered intracranial aneurysms. *Lancet* 1999; 353:1975-1976
11. Barua S, Wakai S, Shwe T, Umenai T: Leprosy elimination through integrated basic health services in Myanmar: the role of midwives in the pre- and post-elimination phases. *Leprosy Rev* 70:174-179, 1999
12. Yoshimoto Y, Wakai S: Cost-effectiveness analysis of screening for asymptomatic, unruptured intracranial aneurysms: A mathematical model. *Stroke* 30: 1621-1627 1999
13. Inaoka E, Wakai S, Nakamura Y, Babily YA, Saghayroun AAR. Correlate of visit regularity among family planning clients in urban Yemen. *Adv Contraception* 1999; 15: 257-274
14. Wakai S. Physicians for peace. *Lancet* 2000; 355: 1365-1366
15. Wakai S. Life after sanctions: the fate of Iraq. *Lancet* 2000; 356: 685
16. Kuroiwa C, Vongphrachanh P, Chosa T, Murakami H, Hashizume M, Wakai S, Tanaka M. Risk of poliomyelitis importation and reemergence in Laos. *Lancet* 2000; 356: 1487-88.
17. Toyama N, Wakai S, Nakamura Y, Andryansyah Arifin. Mother's working status and nutritional status of children under the age of five in urban low-income community, Surabaya, Indonesia. *J Trop Pediatr* 2001; 47: 179-181
18. Jimba M, Wakai S. Is Gandhi's philosophy of non-violence dead in Nepal? *Lancet* 2001;358:1018-2.
19. Nakahara S, Wakai S. Underreporting of traffic injuries involving children in Japan. *Injury Prevention* 2001;7: 242-244
20. Sase E, Wakai S. A world war against terrorism. *Lancet* 2001;358:1365
21. Ichikawa M, Nakahara S, Wakai S. Death with unbelated passengers. *Lancet* 2002;359:43-44
22. Ichikawa M, Okumura J, Wakai S. Two decisions of Japanese court on detained Afghan asylum seekers. *Lancet* 2002;359:448
23. Saengdidtha B, Lapparat G, Torugsa K, Suppadit W, Wakai S. Sexual Behavior and HIV Infection Among Thai Army Conscripts between 1992 and 1998. *Military Med* 2002; 167(4):272-6
24. Nakahara S, Wakai S. Differences between Japanese pre-school and school-age pedestrian mortality and morbidity trends. *Public Health* 2002;116:1-7
25. Kunii O, Nakamura S, Abdur R, Wakai S. The Impact on Health and Risk Factors of the Diarrhoea Epidemics in the 1998 Bangladesh Floods. *Public Health* 2002;116: 68-74
26. Okumura J, Wakai S, Umenai T. Drug utilisation practice at household focusing self-medication in rural communities in Vietnam. *Soc Sci Med* 2002;54:1875-1886
27. Md. Akramul Islam, Susumu Wakai, Nobukatsu Ishikawa, A.M.R. Chowdhury, J. Patrick Vaughan: Tuberculosis control by community health workers in Bangladesh: are they more cost-effective? *Bull WHO* 2002;80:445-450
28. Phoxay C, Okumura J, Nakamura Y, Wakai S. Influence of Women's Knowledge and Health Seeking Behaviour on Maternal Health Care Utilization in Southern Laos. *Asia-Pacific J Public Health* 2001;13:13-18
29. Flores FP, Umenai T, Wakai S. Should community-managed drugstores be phased out? *Asia-Pacific J Public Health* 2001;13:9-12
30. Wakai S. Mobilization of Cuban doctors in developing countries. *Lancet* 2002: 360;92
31. Miura S, Kunii O, Wakai S. Home Gardening in Urban Poor Communities of the Philippines. *Int J Food Sci Nutrition* 2002 (in print)
32. M Hashizume,¹ O Kunii,¹ S Sasaki,² T Shimoda,³ S Wakai¹ and M Chiba. Anemia and Anthropometrical Status of School-age Children in the Aral Sea Region, Kazakhstan. *J Trop Pediatr* (in press)

Clinical Research and Epidemiology

33. Wakai S, Fukushima T, Furihata T, Sano K: Association of cerebral aneurysm with pituitary adenoma. *Surg Neurol* 12:503-507, 1979
34. Wakai S, Fukushima T, Teramoto A, Sano K: Pituitary apoplexy: its incidence and clinical significance. *J Neurosurg* 55:187-193, 1981
35. Sano K, Wakai S, Ochiai C, Takakura K: Characteristics of intracranial meningiomas in childhood. *Child' Brain* 8:98-106, 1981
36. Wakai S, Yamakawa K, Mananka S, Takakura K: Spontaneous intracranial hemorrhage caused by brain tumor: its incidence and clinical significance. *Neurosurgery* 10:437-444, 1982
37. Segawa H, Wakai S, Tamura K, Yoshimasu N, Kakamura O, Ohta M: Computed tomographic measurement of local cerebral blood flow by Xenon enhancement. *Stroke* 14:356-362, 1983
38. Wakai S, Narita J, Hashimoto K, Nagai M: Dermoid cyst communicating with the subarachnoid space and lateral ventricle: demonstration by metrizamide computed tomographic cisternography. *Neurosurgery* 13:696-698, 1983
39. Wakai S, Arai T, Nagai M: Congenital brain tumors. *Surg Neurol* 21:597-609, 1984
40. Wakai S, Nagai M: Ventricular diverticulum. *J Neurol Neurosurg Psychiatry* 47:514-517, 1984
41. Wakai S, Ueda Y, Inoh S, Nagai M: Angiographically occult angiomas: A report of thirteen cases with analysis of the cases documented in the literature. *Neurosurgery* 17:549-556, 1985
42. Wakai S, Nagai M: Histological verification of microaneurysms as a cause of cerebral haemorrhage in surgical specimens. *J Neurol Neurosurg Psychiatry* 52:595-599, 1989
43. Wakai S, Hashimoto K, Watanabe N, Inoh S, Ochiai C, Nagai M: Efficacy of closed-drainage system in treating chronic subdural hematoma: A prospective comparative study. *Neurosurgery* 26:771-773, 1990
44. Iwanaga H, Wakai S, Ochiai C, Narita J, Inoh S, Nagai M: Ruptured cerebral aneurysms missed by initial angiography. *Neurosurgery* 27:45-51, 1990
45. Wakai S, Kumakura N, Nagai M: Lobar intracerebral hemorrhage: A clinical, radiographic and pathologic study of 29 consecutive operated cases with negative angiography. *J Neurosurg* 76: 231-238, 1992
- extracellular space of the brain. *Neurosurgery* 18:548-554, 1986
50. Wakai S, Meiselman SE, Brightman MW: Focal circumvention of blood-brain barrier with grafts of muscle, skin and autonomic ganglia. *Brain Res* 386:209-222, 1986

Biomedical Research

46. Wakai S, Hirokawa N: Development of the blood-brain barrier to horseradish peroxidase in the chick embryo. *Cell Tiss Res* 195:195-203, 1978
47. Wakai S, Matsutani M, Mizutani H, Sano K: Tight junctions in choroid plexus papillomas. *Acta Neuropathol* 45:159-160, 1979
48. Wakai S, Hirokawa N: Development of blood-cerebrospinal fluid barrier to horseradish peroxidase in the avian choroidal epithelium. *Cell Tiss Res* 214:271-278, 1981
49. Wakai S, Meiselman SE, Brightman MW: Muscle grafts as entries for blood-borne proteins into the

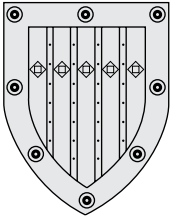

Department of Human Genetics

Outline and Research Objectives

The Department of Human Genetics was established in April 1992 as one of the departments at the newly established School of International Health. The department educates students at the Graduate School of International Health with courses covering basic principles as well as clinical applications of human genetics. A series of lectures on human genetics are also provided to the first year students at the School of Medicine (compulsory). In addition, for undergraduate students at the School of Health Sciences, a series of lectures are given to each of the sophomore (Human Genetics I, compulsory) and junior (Human Genetics II, elective) classes.

The major research projects in the department are: (1) Search for susceptibility genes to rheumatic diseases and other autoimmune diseases, (2) Search for susceptibility genes to clinical subsets of malaria, (3) Genome diversity of Asia-Pacific populations, (4) Search for susceptibility genes to behavioral disorders, and (5) Analysis of gene expression profiles in inflammatory tissues and cell differentiation.

Faculties and Students

Professor and Chair	Katsushi TOKUNAGA, DSc
Associate Professors	Naoyuki TSUCHIYA, MD, DMSc
Associate	Jun OHASHI, DHSc
Postdoctoral Fellow2
Graduate student12
Research student3
Research Technician7
Secretary2

Past Research and Major Accomplishments

- (1) By means of extensive variation screening of a number of candidate genes followed by association analyses with complex diseases including rheumatic diseases, malaria and narcolepsy, several disease-gene associations have been newly found as follows.
 - Rheumatoid arthritis (RA): *LIR1(ILT2)*, *BLYS/BAFF-R*, *TNFR2*, *FCGR3A/HLA-DRB1*
 - Systemic lupus erythematosus (SLE): *TNFR2*, *CD19*, *FCGR2B*, *FCGR3A*
 - Cerebral malaria (in Thailand): *HLA-B*, *TNFA*, *CD36*
 - Severe malaria (in Thailand): *HLA-DRB1*, *iNOS*
 - Narcolepsy: *TNFA*, *TNFR2*
 - ANCA-associated vasculitis: *HLA-DRB1*
- (2) Studies on HLA gene and haplotype distribution in East Asian and Pacific populations have demonstrated genetic affinities and clustering of the populations, multiple migration and dispersal routes of ancestral populations, and the genetic link between Asians and Native Americans.

- (3) Gene expression profiling in synovia from RA patients demonstrated several up-regulated genes including *ID* family genes. Also a number of up-regulated and down-regulated genes including *TNF-TNFR* family were identified in the differentiation of monocytes into dendritic cells.

Current Research

- (1) Establishment of Human SNP (single nucleotide polymorphism) Typing Center for large scale SNP typing (goal: 1,000,000 typing/year).
- (2) Continue the search for susceptibility genes to rheumatic diseases, malaria subsets, and narcolepsy mainly by means of candidate gene approach.
- (3) Screening of novel candidate regions for susceptibility genes to SLE and narcolepsy by means of whole genome association studies.
- (4) Analyses of linkage disequilibrium blocks on chromosome 1 for the determination of primary genes.
- (5) Functional analyses of disease-associated SNPs and *ID* family genes.

Future Prospects

- (1) High-throughput SNP typing in the Human SNP Typing Center will contribute to the identification of susceptibility genes to various complex diseases including allergy, diabetes, hypertension, and infectious diseases.
- (2) Using the new strategy of the whole genome association analyses, several candidate regions for SLE and narcolepsy will be newly found.

- (3) Extensive studies on linkage disequilibrium blocks will contribute to effective search of disease associated genes.
- (4) Further development of new high-throughput SNP typing technologies.

Research Grants

<Only the grants of more than 10,000,000 yen/year are listed below>

1. "Medical Genome Science", Grant-in-Aid for Scientific Research on Priority Areas, Grant-in-Aid for Scientific Research by The Ministry of Education, Culture, Sports, Science and Technology: Human SNP Typing Center. 2001-2004.
2. "Medical Genome Science", Grant-in Aid for Scientific Research on Priority Areas, Grant-in Aid for Scientific Research by The Ministry of Education, Culture, Sports, Science and Technology: Susceptibility genes to rheumatic diseases. 28,000,000 yen/year. 2000-2004.
3. "Genome Informatics Research and Technology Development", by the New Energy and Industrial Technology Development Organization (NEDO): Development of DNA capillary array. 10,000,000 yen/year. 1999-2002.
4. "Genome Diversity Project", by the New Energy and Industrial Technology Development Organization (NEDO): Genome-wide association studies on rheumatoid arthritis. 10,000,000 yen/year. 2001-2004.

Select Publications

1. Tokunaga K, Araki C, Juji T, and Omoto K: Genetic polymorphism of the complement C2 in Japanese. *Hum. Genet.* 58: 213-216, 1981.
2. Tokunaga K, Omoto K, Juji T, and Itoh T: Polymorphism of BF, C2 and GLO in Japanese patients with insulin-dependent diabetes mellitus: Confirmation of an increase of BF*FT. *Hum. Genet.* 62: 86-88, 1982.
3. Tokunaga K, Yukiya Y, and Omoto K: Polymorphism of the complement C6 in Japanese. *J. Immunogenet.* 10: 419-424, 1983.
4. Tokunaga K, Omoto K, Yukiya Y, Sakurai M, Saji H, and Maruya E: Further study on a BF silent allele. *Hum. Genet.* 67: 449-451, 1984.
5. Matsuki K, Juji T, Tokunaga K, Naohara T, Satake M, and Honda Y: Human histocompatibility leukocyte antigen (HLA) haplotype frequencies estimated from the data on HLA class I, II, and III antigens in 111 Japanese narcoleptics. *J. Clin. Invest.* 76: 2078-2083, 1985.
6. Tokunaga K, Dewald G, Omoto K, and Juji T: Family study on the polymorphisms of the sixth and seventh components (C6 and C7) of human complement: Linkage and haplotype analyses. *Am. J. Hum. Genet.* 39: 414-419, 1986.
7. Matsuki K, Juji T, Tokunaga K, Mochizuki M, Hayashi K, Fujino Y, Numaga J, and Yamashita H: HLA antigens in Behcet's disease with refractory attacks. *Tissue Antigens* 29: 208-213, 1987.
8. Tokunaga K, Sauerecker G, Kay P, Christiansen F, Anand R, and Dawkins RL: Extensive deletions and insertions in different MHC supratypes detected by pulsed field gel electrophoresis. *J. Exp. Med.* 168: 933-940, 1988.
9. Watanabe Y, Tokunaga K, Matsuki K, Takeuchi F, Matsuta K, Maeda H, Omoto K, and Juji T: Putative amino acid sequence of HLA-DRB chain contributing to rheumatoid arthritis susceptibility. *J. Exp. Med.* 169: 2263-2268, 1989.
10. Matsuki K, Juji T, Tokunaga K, Takamizawa M, Maeda H, Soda M, Nomura Y, and Segawa M: HLA antigens in Japanese patients with myasthenia gravis. *J. Clin. Invest.* 86: 392-399, 1990.
11. Tokunaga K, Jin F, Mauff G, Nishimukai H, Simeoni E, Suzuki K, Weber W: C6 reference typing report. *Complement Inflamm.* 7: 234-239, 1990.
12. Kuwata S, Tokunaga K, Jin F, Juji T, Sasaki T, and Honda Y: Analysis of HLA-DRB gene in narcolepsy. *N. Engl. J. Med.* 324: 271-272, 1991.
13. Tokunaga K, Zhang WJ, Christiansen FT, and Dawkins RL: The genomic structure of two ancestral haplotypes carrying C4A duplications. *Immunogenet.* 34: 247-251, 1991.
14. Uchigata Y, Kuwata S, Tokunaga K, Eguchi Y, Takayama-Hasumi S, Miyamoto M, Omori Y, Juji T, and Hirata Y: Strong association of insulin autoimmune syndrome with HLA-DR4. *Lancet* 339: 393-394, 1992.
15. Mitsunaga S, Kuwata S, Tokunaga K, Uchikawa C, Takahashi K, Akaza T, Mitomi Y, and Juji T: Family study on HLA-DPB1 polymorphism: Linkage analysis with HLA-DR/DQ and two "new" alleles. *Hum. Immunol.* 34: 203-211, 1992.
16. Bannai M, Mazda T, Tokunaga K, and Juji T: DNA single-strand conformation polymorphism method to distinguish DR4 alleles. *Lancet* 341: 769, 1993.
17. Lin L, Tokunaga K, Ogawa A, Ishikawa Y, Kashiwase K, Akaza T, Tadokoro K, and Juji T: Genotyping and association analysis of HLA-B61 in Japanese. *Hum. Immunol.* 37: 95-100, 1993.
18. Wang L, Juji T, Tokunaga K, Takahashi K, Kuwata S, Uchida S, Tadokoro K, and Takai K: Polymorphic microsatellite markers for the diagnosis of graft-versus-host disease. *N. Engl. J. Med.* 330: 398-401, 1994.
19. Oka T, Matsunaga H, Tokunaga K, Mitsunaga S, Juji T, and Yamane A: A simple method for detecting single base substitutions and its application to HLA-DPB1 typing. *Nucleic Acid Research* 22: 1541-1547, 1994.
20. Tokunaga K, Sideltseva EW, Tanaka H, Uchikawa C, Nieda M, Sideltsev VV, Zhuravleva E, Imanishi T, Itoh K, Akaza T, Takahashi K, Khalturin V, Alexeev LP, and Juji T: Distribution of HLA antigens and haplotypes in the Buryat population in Siberia. *Tissue Antigens* 45: 98-102, 1995.

21. Yoshida M, Ohtsuka R, Nakazawa M, Juji T, and Tokunaga K: HLA-DRB1 frequencies of non-Austronesian-speaking Gidra in South New Guinea and their genetic affinities with Oceanian populations. *Am. J. Phys. Anthropol.* 96: 177-181, 1995.
22. Uchigata Y, Tokunaga K, Nepom G, Bannai M, Kuwata S, Dozio N, Benson EA, Ronningen KS, Spinaz GA, Tadokoro K, Hirata Y, Juji T, and Omori Y: Differential immunogenetic determinants of polyclonal insulin autoimmune syndrome (Hirata's Disease) and monoclonal insulin autoimmune syndrome. *Diabetes* 44: 1227-1232, 1995.
23. Suto Y, Tokunaga K, Watanabe Y, and Hirai M: Visual demonstration of the organization of the human complement C4 and 21-hydroxylase genes by high-resolution fluorescence in situ hybridization. *Genomics* 33: 321-324, 1996.
24. Lin L, Tokunaga K, Tanaka H, Nakajima F, Imanishi T, Kashiwase K, Bannai M, Mizuno S, Akaza T, Tadokoro K, Shibata Y, and Juji T: Further molecular diversity in the HLA-B15 group. *Tissue Antigens* 47: 265-274, 1996.
25. Ogasawara K, Yabe R, Uchikawa M, Saitou N, Bannai M, Nakata K, Takenaka M, Fujisawa K, Ishikawa Y, Juji T and Tokunaga K: Molecular genetic analysis of variant phenotypes of the ABO blood group system. *Blood* 88: 2732-2737, 1996.
26. Fujiwara K, Isa K, Oka T, Maekawajiri S, Yamase A, Akaza T, Tadokoro K, Juji T, Shibata Y, and Tokunaga K: Large-scale DNA typing for human platelet alloantigens by PCR-PHFA (preferential homoduplex formation assay). *Brit. J. Haematol.* 95: 198-203, 1996.
27. Bannai M, Tokunaga K, Tanaka H, Lin L, Kashiwase K, Tokunaga K, and Juji T: Five HLA-B22 group alleles in Japanese. *Tissue Antigens* 49: 376-382, 1997.
28. Miyake M, Nakahori Y, Matsushita I, Kobayashi K, Mizuno K, Hirai M, Kanazawa I, Nakagome Y, Tokunaga K, and Toda T: YAC and cosmid contigs encompassing the Fukuyama-type congenital muscular dystrophy (FCMD) candidate region on 9q31. *Genomics* 40: 284-293, 1997.
29. Watanabe Y, Tokunaga K, Geraghty DE, Tadokoro K, and Juji T: Large scale comparative mapping of MHC class I region of predominant haplotypes in Japanese. *Immunogenet.* 46: 135-141, 1997.
30. Tokunaga K, Ishikawa Y, Ogawa A, Wang H, Mitsunaga S, Moriyama S, Lin L, Bannai M, Watanabe Y, Kashiwase K, Tanaka H, Akaza T, Tadokoro K, and Juji T: Sequence-based association analysis of HLA class I and II alleles in Japanese supports conservation of common haplotypes. *Immunogenet.* 46: 199-205, 1997.
31. Tsuchiya N, Shiota M, Moriyama S, Ogawa A, Komatsu-Wakui M, Mitsui H, Geraghty ED, and Tokunaga K: MICA allele typing of HLA-B27 positive Japanese patients with seronegative spondyloarthropathies and healthy individuals: Differential linkage disequilibrium with HLA-B27 subtypes. *Arthritis Rheum.* 41: 68-73, 1998.
32. Ogawa A, Tokunaga K, Lin L, Kashiwase K, Tanaka H, Herrero MJ, Vilches C, Park MH, Jia GJ, Chinge N-O, Sideltseva EW, Ishikawa Y, Akaza T, Tadokoro K, and Juji T: Diversity of HLA-B61 alleles and haplotypes in East Asians and Spanish Gypsies. *Tissue Antigens* 51:356-366, 1998.
33. Kobayashi K, Nakahori Y, Miyake M, Matsumura K, Kondo-lida E, Nomura Y, Segawa M, Yoshioka M, Saito K, Osawa M, Hamano K, Sakakibara Y, Nonaka I, Nakagome Y, Kanazawa I, Nakamura Y, Tokunaga K, and Toda T: An ancient retrotransposal insertion causes Fukuyama-type congenital muscular dystrophy. *Nature* 394: 388-392, 1998.
34. Wuerzer R, Witzel-Schloemp K, Tokunaga K, Fernie BA, Hobart MJ, and Orren A: Reference typing report for complement components C6, C7, and C9 including mutations leading to deficiencies. *Exp. Clin. Immunogenet.* 15: 268-285, 1998.
35. Komata T, Tsuchiya N, Matsushita M, Hagiwara K, and Tokunaga K: Association of tumor necrosis factor receptor 2 (TNFR2) polymorphism with susceptibility to systemic lupus erythematosus. *Tissue Antigens* 53(6): 527-533, 1999.
36. Komatsu-Wakui M, Tokunaga K, Ishikawa Y, Kashiwase K, Moriyama S, Tsuchiya N, Ando H, Shiina T, Geraghty DE, Inoko H, and Juji T: MIC-A polymorphism in Japanese and a MIC-A-MIC-B null haplotype. *Immunogenet.* 49(7/8): 620-628, 1999.
37. Hatta Y, Ohashi J, Imanishi T, Kamiyama H, Iha M, Shimabukuro T, Ogawa A, Tanaka H, Akaza T, Gojobori T, Juji T, and Tokunaga K: HLA genes and haplotypes in Ryukyuan suggest a recent gene flow to the Okinawa islands. *Hum. Biol.* 71(3): 353-365, 1999.
38. Chida S, Hohjoh H, and Tokunaga K: Molecular analyses of the possible RNA-binding protein gene located in the human leukocyte antigen (HLA)-DR subregion. *Gene* 240: 125-132 1999.
39. Bannai M, Ohashi J, Harihara S, Takahashi Y, Juji T, Omoto K, and Tokunaga K: Analysis of HLA genes and haplotypes in Ainu (from Hokkaido, northern Japan) supports the premise that they descent from Upper Paleolithic populations of East Asia. *Tissue Antigens* 55 (2):128 -139, 2000.
40. Keicho N, Ohashi J, Tamiya G, Nakata K, Taguchi Y, Azuma A, Ohishi N, Emi M, Park MH, Inoko H, Tokunaga K, and Kudoh S: Fine localization of a major disease-susceptibility locus for diffuse panbronchiolitis. *Am. J. Hum. Genet.* 66 (2): 501-507, 2000.
41. Shibue T, Tsuchiya N, Komata T, Matsushita M, Shiota M, Ohashi J, Wakui M, Matsuta K, and Tokunaga K: Tumor necrosis factor α 5'-flanking region, TNF receptor II, and HLA-DRB1 polymorphisms in the Japanese patients with rheumatoid arthritis. *Arthritis Rheum.* 43 (4): 753-757, 2000.
42. Ohashi J, Yamamoto S, Tsuchiya N, Hatta Y, Komata T, Matsushita M, and Tokunaga K: Comparison of statistical power between 2 \times 2 allele frequency and allele positivity tables in case-control studies of com-

- plex diseases genes. *Ann. Hum. Genet.* 65(2): 197-206, 2001.
43. Ogasawara K, Yabe R, Uchikawa M, Nakata K, Watanabe J, Takahashi Y, and Tokunaga K: Recombination and gene conversion-like events may contribute to ABO gene diversity causing various phenotypes. *Immunogenet.* 53(3): 190-199, 2001.
 44. Sakurai D, Yamaguchi A, Tsuchiya N, Yamamoto K, and Tokunaga K: Expression of ID family genes in the synovia from patients with rheumatoid arthritis. *Biochem. Biophys. Res. Commun.* 284(2): 436-442, 2001.
 45. Lapteva N, Ando Y, Nieda M, Hohjoh H, Okai M, Kikuchi A, Dymshits G, Ishikawa Y, Juji T, and Tokunaga K. Profiling of genes expressed in human monocytes and monocyte-derived dendritic cells using cDNA expression array. *Br. J. Haematol.* 114(1): 191-197, 2001.
 46. Tokunaga K, Ohashi J, Bannai M, and Juji T: Genetic link between Asians and Native Americans: Evidence from HLA genes and haplotypes. *Hum. Immunol.* 62(9): 1001-1008, 2001.
 47. Sirikong M, Tsuchiya N, Chandanayingyong D, Bejrachandra S, Suthipinittharm S, Luangtrakool K, Srinak D, Thongpradit R, Siriboonrit U, and Tokunaga K: Association of HLA-DRB1*1502-DQB1*0501 haplotype with susceptibility to systemic lupus erythematosus in Thais. *Tissue Antigens* 59 (2): 113-117, 2002.
 48. Kyogoku C, Dijstelboem M.H, Tsuchiya N, Hatta Y, Kato H, Yamaguchi A, Fukazawa T, Jansen D.M, Hashimoto H, Winkel G.J. J, Kallenberg G.M. C, and Tokunaga K: Fcg receptor gene polymorphisms in Japanese patients with systemic lupus erythematosus: Contribution of FCGR2B to genetic susceptibility. *Arthritis Rheum.* 46(5): 1242-1254, 2002.
 49. Ohashi J, Naka I, Patarapotikul J, Hananantachai H, Looareesuwan S, and Tokunaga K: Significant association of longer forms of CCTTT microsatellite repeat in inducible nitric oxide synthase (iNOS) promoter with severe malaria in Thailand. *J. Infect. Dis.* 186: 578-581, 2002.
 50. Kuroki K, Tsuchiya N, Tsao B, Grossman J, Fukazawa T, Hagiwara T, Kano H, Takazoe M, Iwata T, Hashimoto H, and Tokunaga K: Polymorphisms of human CD19 gene: Possible association with susceptibility to systemic lupus erythematosus in Japanese. *Genes. Immun.* (in press)
(Number of the other original papers in English: 229)

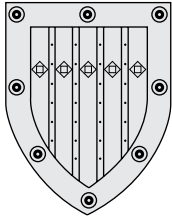

Department of Developmental Medical Sciences

Outline and Research Objectives

In 1996, the Department of Mother and Child Health was formed at the University of Tokyo. In Japan, it was the first division in International Health, which specifically focused on maternal and child health issues. Maternal and child health involves all activities to maintain and promote psychological and physiological health of mothers and children. The field of maternal and child health covers (1) countermeasure for infectious diseases, (2) maternal and child nutrition, (3) prevention of diseases, and (4) protection of mothers and children from environmental unhealthy factors.

The study of maternal and child health not only covers research areas where clinical intervention is possible but also it is beneficial for studying diseases where intervention is difficult and abnormalities cannot be prevented. Maternal and child health research helps administration and health policy makers to develop policies and to take decisions that are in accordance with the current problems and are in the best interest of the communities. Since 1998, in order to broaden its vision in research, scope of work and teaching activities the division changed its name to "Developmental Medical Sciences". Aging, human and environment, and their related items are newly added to our theme. This comes under International Biomedical Sciences, which is a division of Institute of International Health. Since then, our research scope and work have expanded to foreign countries, mainly in Asia

Faculties and Students

Professor	Hiroshi Ushijima, M.D., Ph.D. (1995 - to date)
Associate Professor	Hideoki Fukuoka, M.D., Ph.D.
Associate	2
Postdoctoral Fellow	3
Graduate student	20
Research student.....	4
Secretary	2

Past Research and Major Accomplishments

Background

After graduation from medical university and obtaining license of medical doctor, I first worked at Tokyo University Hospital and related hospitals as a pediatrician. At the same time, I studied clinical research regarding pediatric infection, pediatric immunology, and pediatric neurology. My research produced results, which were related to clinical medicine. Following that I had an opportunity to study in the United States as a virologist (Research fellow) at State University of Alabama for about 2 years. My major was molecular study of Bunyaviruses, which infect humans as well as animals. Some of the viral

strains caused emerging diseases. During my research, I discovered reassortant viruses and non-structure proteins in the family. After returning to Japan, in addition to being a pediatrician I also worked as a researcher on molecular epidemiology, diagnosis and development of medicine for diarrhea caused by viruses and HIV at National Institute of Infectious Diseases (NIID) and National Institute of Public Health (NIPH) as a chief and director, respectively. After that, I moved to the University of Tokyo in 1995. Since then, I have been engaged in various researches in topics ranging from infection, nutrition, maternal and child health in the world, with a special focus in Asia.

Followings are few researches, which I had carried out and supervised in the University of Tokyo. The researches include basic and field studies.

Diarrheal viruses

Rotavirus disease is an important diarrheal disease especially in children. More than 500,000 children die every year especially in developing countries. In the developed countries, almost all infants have viral disease within 2 years after birth. My experience in working on molecular epidemiology of rotavirus in Japan expands over a period of a little more than 20 years. Besides, in the past four years, extensive collaboration has been done with researchers, microbiolo-

gists and pediatricians in countries like Korea, China, Vietnam and Thailand. It has been done with similar themes of epidemiological studies of diarrheal viruses. These studies are important to develop vaccines because serotypes and genotypes sometimes change and the most appropriate vaccines are needed.

Major diarrheal viruses are rotavirus, astrovirus, adenovirus, Norwalk virus and Sapporo virus. Currently, we study all of them up to molecular level. Immunodeficient persons discharge the viruses for long time. Through research we have highlighted complications of encephalopathy, hepatitis and others, which were caused by these viruses. Stool samples, slightly over 10,000 were collected for more than 20 years in five areas in Japan. Besides Japan, stool samples were also collected in Asian countries. In complicated cases, cerebrospinal fluids, bloods and liver tissues are also examined at times.

I have the honor of pioneering the concept and developing molecular epidemiology of diarrheal viruses in Japan. During the process, I established particulars about diarrheal viruses causing encephalopathy and other complications in humans. Due to seasonal changes and serotype distribution, detail analyses of all the viruses were done during the past 20 years. Reassortment and recombination were also discovered. The changes in serotypes or genotypes were affected principally by time and also by geographic distributions across the countries. We established the facts about Norwalk virus spreading in early winter and rotavirus spreading in late winter in Japan. However the detail of mode of spread of viruses is still largely unknown, except for outbreaks of food poisoning and outbreaks at institutes. We also brought forward the fact that rotavirus infection starts at the same time all over Japan. We have established a research system in Japan and nowadays we are examining the shellfishes and sewerages regularly. The results of the research will contribute to the health policy and decision-making in Japan.

We newly developed RT-PCR, enzyme immunoassay, immunochromatography and latex agglutination tests for rapid, easy and sensitive diagnosis. Anti-diarrheal virus agents are examined by *in vitro* assay. We found that tea extracts, pine seed extracts and poly IC were effective on rotavirus infection. This method is useful to find anti-viral agents *in vitro*. *In vivo* assays by using mouse model are also used. Mouse pups born to and nursed by dams fed *Bifidobacterium breve* and immunized orally with rotavirus were more strongly protected against rotavirus-induced diarrhea than those born to and nursed by dams immunized with rotavirus only.

HIV and hepatitis viruses

HIV and hepatitis infections have become impor-

tant areas of research not only in Asia in general but also in Japan in particular. It is now an established fact that HIV, hepatitis B and C viruses cause mother to child infection. Transportation of such sample safely across different countries has always been a problem. To transport HIV samples safely from foreign countries, we introduced the use of filter paper method for blood and saliva. New primers were designed for subtyping of HIV subtype B and E. We succeeded to determine HIV from several countries. Now we are developing primers for all subtypes. The PCR was useful for the samples from blood, saliva and breast milk. Basic research of HIV infection was also done through collaboration with Prof. Muller in Germany; it was found that exposure to gp120 of HIV induces apoptosis in neuronal cell culture. Moreover, I am still a member of National research group to find anti-HIV candidate drugs. For the said purpose we screen anti-HIV drugs distributed from pharmaceutical companies. We have found some effective chemicals *in vitro*. Molecular Epidemiology of hepatitis B has been done through the collaboration with Dr. Abe, NIH Japan. Our results revealed that there was high prevalence of HBV pre-S mutant in Asia, where there are high endemic regions of HBV, except for Japan. The appearance of HBV mutation seemed to be correlated to duration of persistent infection and genotypes of HBV. In fact, we found higher prevalence of HBV mutation in hepatocellular carcinoma patients and genotypes B and C. Mode of transmission of hepatitis C infection in Japan is different to that in Asia. The patients in most countries in Asia are due to co-infection with HIV but the majority of the patients in Japan are due to misuse of syringes.

Field studies

The field study of maternal and child health is also integral part of our department. One project is "maternal and child health in minority groups in Asian countries". Dr. Li Y, a researcher from Yunnan, China, has conducted a project in rural minority area of Yunnan. An interview of 2019 rural mother was conducted. We found that maternal child-rearing behaviors differed significantly among ethnic groups as well as between urban and rural areas. The behaviors were significantly associated with maternal education level, family type, family income, maternal age at delivery, and number of children in the family. We continued this project and found the malnutrition was especially due to vitamin B₁ deficiency. The main reason was eating too much polished rice, deficiency of vegetables and longer time for cooking.

Current Research

Viruses

We have continued epidemiological studies of diarrheal viruses, HIV and hepatitis, especially in children. It will help achieve the final goal of decreasing mortality and morbidity caused by these diseases. Enzyme immunoassay, (RT-) PCR, sequence analysis and other methods are used for the diagnosis. Immunochromatographic method is useful for diagnosis in outpatient clinics because of simplicity and rapidity.

We are trying to develop;

- (1) Diarrheal virus detection kit for rotavirus, enteric adenovirus, astrovirus and Norwalk virus,
- (2) Hepatitis virus detection kit for hepatitis A, B, C and E, and TTV.

To make antibodies for immunochromatograph, we culture the viruses that grow *in vitro*, make synthetic peptides and make virus like particles with genetic engineering. Rapid detection kit using gene amplification is also proceeding.

Field research

Asia: As further activity in Yunnan, we conducted training course of maternal and child health for about 60 health workers and physicians who belong to minority areas. Education session focused on proper cooking methodology, general physical examination, knowledge about HIV and other diseases. We made pamphlets and CD. Then, the health workers and physicians teach the caregivers by using them. Vitamin B1 is used in the area as a treatment. In addition, we used rapid methods of detecting viruses in the areas.

A student from Vietnam, who worked before at NGO GROUP, is studying in minority group in rural mountain areas in north part of Vietnam. Physical conditions of infants and attitudes of caregivers are examined every 3 months after birth for 2 years. In 2003, a student will come from Laos. She will also conduct similar research in Laos. Maternal and child health in minority groups in the border areas in China, Thailand, Laos and Vietnam are examined and intervention is planned.

Japan: We are conducting a project of maternal and child health in ethnic minority in Japan. This project started in 2001. Due to globalization, children of ethnic minority group have increased in Japan in the last 10 years. However health check system, medical care and health insurance system are not enough for them. In addition, education of mother and child, communication among health workers and residents are sometimes not sufficient for them. We have multi-pronged approach for the research. It includes (a)Ask

3000 local health workers about their activities on mother and child health in ethnic minority groups, (b)Interview health workers, physicians, NGO members and administrators deeply at two local areas how they succeeded in high quality of health care for minority groups. (c)Some families stay in Japan over the time than officially allowed. They do not receive enough medical care. To improve the situation, we examine it and make proposals for their better living. (d)Lack of communication among themselves and with health workers causes anxiety among them. Proper and efficient communication system and health service system will be suggested. (e)In addition to health care, education of mother and child is also needed. Both are related and necessary for their better health. All minorities in high class, middle class and lower class should be improved irrespective of ethnicity, religion or country of origin.

Others

Other activities are concurrently carried out in my department are such as relation between development of voice / sucking and growth, mother's relaxation/infant development and touch care, maternal mortality and obesity in developed and developing countries. Moreover, other staffs in the division have their own projects. We regularly communicate, help and discuss together on our research agendas.

Future Prospects

21st century has started in the wake of social chaos. World has become a global village and emerging and reemerging infectious diseases are gaining importance. While, exchanges of people and information are rapidly increasing via various modes of transportation and internet service. Under these circumstances, the health of mother, child, and elderly is especially important. Our research of health in children among ethnic minority groups will become highly valuable. The results will contribute in making evidence based decision as regards maternal and child health.

In order to keep environment safe, a decrease in infection diseases and malnutrition are equally important. Our diagnostic methods are useful to for the above said cause and thus help fight against diseases. Further development of vaccine, medicine and molecular epidemiological survey of infection is the need of the time, to make the future safe for our generations in the times to come.

Followings are schema of our research of past, present and future.

	Developmental	Medical	Sciences
	Maternal and Child Health	Environment & Education <i>Asia and Japan</i>	
Basic Research	Infection (Diarrheal viruses, hepatitis viruses, HIV) · Diagnosis · Molecular Epidemiology · Pathogenesis · Treatment Nutrition (deficiency, obesity etc) · Diagnosis · Treatment Development & Health care · Analysis · Intervention · Estimation	Stool, Blood, Food, Sewerage <i>Japanese students & researchers</i> <i>Foreign students & researchers</i> Collaboration Interview, Physical test	
Field Research	Minority groups · Administration (health service) · Information (communication) · Intervention · Estimation	Questionnaire, Interview, Internet <i>Japanese students & researchers</i> <i>Foreign students & researchers</i> Collaboration	

Research Grants

a: Health-welfare and labor science research

- (1) Maternal and child health in multi-racial cultural society, a project of "general research on child and family" (2001-2004) 11,000,000 yen/3years
- (2) Research of survey of microorganism contamination in foods and evaluation of safety, a project of "general research on safety of food and chemicals" (2001-2004) 1,000,000 yen/year

b: Basic research supported by the ministry of education and science

- (1) Diagnosis, molecular epidemiology, pathology, prevention and treatment of diarrheal viruses. (2002-2005) 18,891,000 yen(2002)
- (2) Molecular epidemiological study of maternal and child infection in Asia. (2001-2004) 4,200,000 yen(2002)

c: Others

- (1) Research for gravity and infection supported by space development project. 520,000 yen(2002)
- (2) Research for Nano-technology supported by human science foundation. Other small grants are not shown. 7,500,000 yen/year

Select Publications

1. Ushijima H, Nishio O, Klocking R, Schroder HC, Perovic S, Muller WEG: Exposure to gp120 of HIV-1 induces an increase release of arachidonic acid in rat neuronal cells followed by NMDA receptor-mediated neurotoxicity. *Eur J Neuroscience* 7:1353-1359,1995.
2. Kakizawa J, Ushijima H, Ando S, Yamamoto Y, Oka S, Ikeda Y, Muller WEG: Detection of HIV-1 RNA and DNA in saliva by RT-PCR and PCR under different condition. *Acta Paediatrica Japonica* 38 : 218-223, 1996.
3. Yasui H, Kiyoshima J, Ushijima H. Passive protection against rotavirus-induced diarrhea of pups born to and nursed by dams fed *Bifidobacterium breve* YIT4064 *J Infect Dis* 172: 403-409, 199
4. Schroder HC, Ushijima H, Theis C, Seve A-P, Hubert J, Muller WEG. Expression of nuclear lectin carbohydrate-binding protein 35 in human immunodeficiency virus type 1-infected Molt-3 cells *J AIDS* 9:340-348, 1995.
5. Saito K, Ushijima H, Nishio O, Oseto M, Motohiro H, Ueda Y, Takagi M, Nakaya S, Ando T, Glass R, Zaiman K. Detection of astroviruses from stool samples in Japan using reverse transcription and polymerase chain reaction amplification. *Microbiology and Immunology* 39:825-828, 1995.
6. Wen L, Ushijima H, Kakizawa J, Fang Z-Y, Nishimura S, Nishio O, Morokawa S, Motohiro T. Genetic variation in VP7 gene of human rotavirus serotype 2 (G2 type) isolated in Japan, China, and Pakistan. *Microbiology and Immunology* 39:911-915, 1995.
7. Ushijima H, Morikawa S, Mukoyama A, Nishio O. Characterization of VP4 and VP7 of a murine rotavirus (YR-1) isolated in Japan. *Jpn. J. Med. Sci. Biol.* 48: 237-247, 1995.
8. Kakizawa J, Ushijima H, Morishita Y, Oka S, Ikeda Y, Muller WEG. Diversity of HIV type 1 envelope V3 loop region in saliva. *Human retrovirus and AIDS*, 12: 561-563, 1996.
9. Nakayama M, Ueda Y, Kawamoto H, Yue HJ, Saio K, Nishio O, Ushijima H. Detection and sequencing of Norwalk-like viruses from stool samples in Japan using RT-PCR. *Microbiology and Immunology* 40: 317-320, 1996.
10. Yue Han-Jun, Hiroshi Ushijima. Detection and genotyping of astroviruses by RT-PCR and sequencing *J. Jap Assoc Infect Dis* 70: 1220-1226, 1996
11. Perovic S, Schroder HC, Pergande G, Ushijima H, Muller WEG. Downregulation of Bcl-2 and glutathione level in neuronal cells in vitro treated with the prion protein fragment (PrP106-126): Prevention by flupirtine *Experimental Neurology* 147:518-524, 1997.
12. Akihara S, Nakayama M, Kakizawa J, Bosu K, Izumi K, Ushijima H. An outbreak of Norwalk-like virus

- infection in Tokyo and Saitama in late 1995. *J. Jap. Assoc. Infect. Dis.* 70: 840-841, 1996.
13. Wen L, Nakayama M, Yamanishi Y, Nishio O, Fang Z-Y, Nakagomi O, Araki K, Nishimura S, Hasegawa A, Muller WEG, Ushijima H. Genetic variation in the VP7 gene of human rotavirus serotype 3 (G3 Type) isolated in China and Japan. *Arch Virol* 142:1481-1489, 1997.
 14. Kakizawa J, Ushijima H, Wen L, Ikeda Y, Oseto K. Genetic analysis of the capsid region of human astrovirus serotype 3 isolated in Japan. *Microbiol Immunol* 41: 637-640, 1977.
 15. Schroder HC, Perovic S, Ushijima H, Muller WEG. Mechanisms of prion^s c- and HIV-1 gp120 induced neuronal cell death. *Neuro Toxicology* 19:683-688, 1998.
 16. Kato H, Horino A, Sakurai S, Ushijima H, Komuro K, Uchida T: Inhibition of tumor cell growth by murine splenic adherent cells stimulated with IFN-gamma Int *Arch Allergy Immunol* 115:115-120, 1998.
 17. Hakamada-Taguchi R, Kato T, Ushijima H, Murakami M, Uede T, Nariuchi H. Expression and co-stimulatory function of B7-2 on murine CD4+ T cells. *Eur J Immunol* 28:865-873, 1998.
 18. Matsui M, Ushijima H, Hachiya M, Kakizawa J, Leying Wen, Oseto M, Morooka K, Kurz JB. Detection of serotypes of astroviruses by reverse transcription-polymerase chain reaction and homologies of the types by the sequencing of Japanese Isolates. *Microbiol. Immunol.* 42: 539-547, 1998.
 19. Cao X-R, Akihara S, Fang Z-Y, Nakagomi O, Ushijima H. Genetic variation in the VP4 gene and the NSP4 gene of human rotavirus serotype 3 (G3 type) isolated in China and Japan. *Microbiol Immunol* 43(2):171-175, 1999.
 20. Adhikary AK, Zhou Y, Kakizawa J, Numaga J, Akihara S, Fang ZY, Ushijima H. Distribution of rotavirus VP4 genotype and VP7 serotype among Chinese Children. *Acta Paediatrica Japonica* 40:641-643, 1998.
 21. Abe T, Kobayashi M, Araki K, Ushijima H. Viral infection-new concepts and treatment -infantile convulsion and viral infection- *Brain and Development*, 20:392-393, 1998.
 22. Li Y, Liu J, Liu F, Guo G, Anme T, Ushijima H. Maternal child-rearing behaviors correlates in rural minority areas of Yunnan, China. *Developmental and behavioral pediatrics* 21: 114-122, 2000
 23. Li Y, Guo G, Shi A, Li Y, Anme T, Ushijima H. Prevalence and correlates of Malnutrition among Children in Rural Minority Areas of China. *Pediatrics International* 41:549-556, 1999
 24. Li Y, Kong L, Hotta M, Wongkhomthong S, Ushijima H. Breast feeding in Bangkok, Thailand: the Current Status, Maternal Knowledge, Attitude and Social Support. *Pediatrics International* 41:648-654, 1999
 25. Nishiwaki M, Yasumizu T, Hoshi K, Ushijima H. The effect of pregnancy, lactation, and weaning on the bone mineral density of rats determined by dual-energy X-ray absorptionmetry. *Endocrine Journal* 46: 711-716, 1999.
 26. Sakamoto T, Wang Q-H, Akihara S, Kim B, Nishimura S, Kaneshi K, Nakaya S, Ueda Y, Sugita K, Motohiro T, Nishimura T, Ushijima H. Molecular epidemiology of astrovirus in Japan from 1995 to 1998 by RT-PCR with serotype-specific Primers (1 to 8) *J Med Virol* 61:326-331, 2000.
 27. Hachiya M, Matsui M, Sanogo M, Oseto M, Morooka K, Ushijima H. Genetic variation in the capsid region of human astrovirus serotype 4 isolated in Japan. *Microbiol Immunol* 43(11), 1067-1070, 1999.
 28. Ushijima H, Perovic S, Leuck J, Rytik P, Muller WEG, HC Scroder.: Suppression of PrPsc- and HIV-1 gp120 induced neuronal cell death by sulfated colominic acid. *J Neurovirology* 5:289-299, 1999.
 29. Tanaka N, Shimoike T, Ishii K, Suzuki R, Suzuki T, Ushijima H, Matsuura Y, Miyamura T. Selective binding of hepatitis C virus core protein to synthetic oligonucleotides corresponding to the 5'untranslated region of the viral genome. *Virology* 270; 229-236, 2000.
 30. Konishi K, Gu Y, Hatano I, Ushijima H. Effect of colominic acid on enteric-virus (rotavirus, poliovirus and Coxsackievirus) infection in vitro. *Japanese Journal of Infectious Diseases. Jpn J Infect Dis* 53:62-66, 2000.
 31. Muller WEG, Laplanche JL, Ushijima H, Schroder HC. Novel approaches in diagnosis and therapy of Creutzfeldt-Jakob disease. *Mechanisms of aging and development* 31:116(2-3) 193-218, 2000
 32. Ushijima H. Rotavirus infection in Asia. *Pediatrics International*. 42:392-394, 2000
 33. Kohno H, Akihara S, Nishio O, Ushijima H. Development of a simple and rapid latex test for rotavirus in stool. *Pediatrics International* 42:395-400, 2000
 34. Maneekarn N, Ushijima H. Epidemiology of rotavirus infection in Thailand. *Pediatrics International* 42:415-421, 2000
 35. Nishio O, Matsui K, Lan DTP, Ushijima H, Isomura S. Rotavirus infection among infants with diarrhea in Vietnam. *Pediatric International* 42: 422-424, 2000
 36. Zhou Y, Li L, Kim B, Kaneshi K, Nishimura S, Kuroiwa T, Nishimura T, Sugita K, Ueda Y, Nakaya T, Ushijima H. Rotavirus infection in children in Japan. *Pediatric International*. 42:428-439, 2000
 37. Gu Y, Gu Q, Kodama H, Muller WEG, Ushijima H. Development of anti-rotavirus agents in Asia. *Pediatric International* 42:440-447, 2000.
 38. Wang QH, Kakizawa J, Wen L, Simizu M, Nishio O, Fang Z, Ushijima H. Genetic Analysis of the Capsid Region of Astroviruses. *J Med Virol* 64:245-255, 2001.
 39. Jonassen CM, Jonassen TO, Saif YM, Snodgrass DR, Ushijima H, Shimizu M, Grinde B. Comparison of capsid sequences from human and animal astroviruses. *J Gen Virol*. 82:1061-1067, 2001.
 40. Abe T, Kobayashi M, Araki K, Kodama H, Fujita Y, Shinozaki T, Ushijima H. Infantile convulsions with mild gastroenteritis. *Brain & Development* 22:301-306, 2000.
 41. Adhikary AK, Numaga J, Kaburaki T, Kawashima H, Kato S, Arai M, Miyata K, Simizu H, Suzuki E,

- Yagyu F, Ushijima H. Rapid detection and typing of oculopathogenic strain of subgenus D adenoviruses by fiber based PCR and restriction enzyme analysis. *Investigative ophthalmology & visual science*. 42: 2010-2015, 2001.
42. Li Y, Shi A, Wan Y, Hotta M, Ushijima H. Child behavior problems: Prevalence and correlates in rural minority areas of China. *Pediatrics International*. 43:651-661, 2001.
 43. Tani H, Nishimura M, Ushijima H, Miyamura T, Matsuura Y. Characterization of cell-surface determinants important for baculovirus infection. *Virology* 279: 343-353, 2001.
 44. Kudo S, Zhou Y, Cao XR, Yamanishi S, Nakaya S, Ushijima H. Molecular characterization in the VP7, VP4 and NSP4 genes of human rotavirus serotype 4 (G4) isolated in Japan and Kenya. *Microbiol Immunol* 45 : 167-171, 2001.
 45. Gu Y, Kodama H, Murata Y, Mochizuki D, Yanagawa Y, Ushijima H, Shiba T, Lee CC. Mutations in the ATP7A gene and copper metabolism in patients with Menkes disease and occipital horn syndrome. *American Journal of Medical Genetics* 99:217-222, 2001.
 46. Kakizawa J, Nitta Y, Yamashita T, Ushijima H, Katow S. Mutations of rubella virus vaccine TO-336 strain occurred in the attenuation process of wild promotor virus. *Vaccine* 19: 2793-2802, 2001.
 47. Yamaguchi K, Ushijima H, Hisano M, Inoue Y, Shimamura T, Hirano T, Muller WEG. Immunomodulatory effect of gold sodium thiomalate of murine acquired immunodeficiency Syndrome. *Microbiol Immunol* 45:549-555, 2001.
 48. Zhou Y, Supawadee J, Khawan C, Tonusin S, Peerakome S, Kim B, Kaneshi K, Ueda Y, Nakaya S, Akatani K, Maneekarn N, Ushijima H. Characterization of human rotavirus serotype G9 isolated in Japan and Thailand 1995 to 1997. *J Med Virol* 65:619-628,2001.
 49. Yagyu F, Ikeda Y, Sugiura W, Wongkhomthong SA, Masuda M, Ushijima H. Differentiation of serotypes B and E of human immunodeficiency virus type 1 by polymerase chain reaction using novel env gene primers. *J Virol Methods*;10: 11-20. 2002
 50. Li Luibai, Thi Phuong Lan D, Hoa NT. Prevalence of breast-feeding and its correlates in Ho Chi Minh City, Vietnam. *Pediatrics International* 44: 47-54,2002. Other 20 English papers from 1995 to 2002. (Total 70 papers)
- 10 majors are No.1, No.3, No.22, No.26, No..28, No.32, No.38, No.40, No.41, No.48 and No.49.

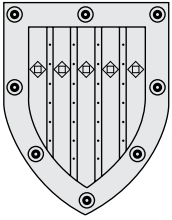

Department of Human Ecology

Outline and Research Objectives

In 1965, our department was established in the School of Health Sciences. From 1966 to 1972, however, there was no full-time professor in our department and thus its scientific activities were limited. Between 1972 and 1976, Professor Akira Koizumi took the office and made efforts for founding the bases in this new field, focusing on environmental health and population analysis. For three years from 1976 when Professor Koizumi transferred to Department of Public Health in our university, however, there was no professor again. In 1979, Professor Tsuguyoshi Suzuki transferred from Tohoku University, and since then research activities of our department have flourished; in this period, particularly in the later half, I fully assisted Professor Suzuki as an associate professor. In 1992, when I took his place, our department was reorganized as one of six departments in the newly established School of International Health.

Regarding the research objectives, human ecology is unique in elucidating health and survival of humans at the individual and population levels, particularly from the relations or interactions with their environment (not only the natural components but also the sociocultural components). Thus, the research of human ecology aims to integrate various aspects, i.e. biomedical, environmental and sociocultural, as far as possible.

Since 1972 and particularly since 1979, the staff and students in our department have conducted fieldworks and experimental works, with special interest in the linkage between them. For the former, various populations in the Asia-Oceania region have been investigated, focusing on food-producing and consuming activities, nutritional and health status, population dynamics including births, deaths and migrations, and infectious and chronic degenerative (lifestyle-related) diseases; my own major contributions were related to the fieldworks. For the latter, toxicological and nutritional examinations have been conducted for biological specimens (i.e. urine, blood and hair) and environmental samples (i.e. water and foods), most of which were collected in our fieldworks; in addition, the associated animal experiments have also been carried out.

Faculties and Students (in October 2002)

Professor and Chair	Ryutaro Ohtsuka, D.Sc., since 1992.
Associate Professor	Chiho Watanabe, Ph.D.
Associates2
Postdoctoral Fellow1 (foreigner).
Graduate Students13 (including 3 foreigners).
Research Students5 (including 3 foreigners).
Secretaries3 (1 full-time and 2 part-time).

Past Research and Major Accomplishments

It is reasonable to review the whole research activities of our department from the 1980s to the recent past since I, as an associate professor from 1981 to 1992, actively participated in most of them, while assisting, and collaborating with, the then Professor T. Suzuki. For convenience, the major research foci are shown in Table 1, separately for the 1st period (up

to 1992, when I became a professor) and the 2nd period (up to the late 1990s); in the same table, those in the current and future periods are also mentioned. It is noted that this table does not include the common themes, such as nutritional adaptation, behavioral adaptation and population dynamics, which have always been pursued.

The most important goal of my research (with Professor T. Suzuki and other staff) in the 1980s was to establish the research framework of human ecology, focusing on human population ecology. Briefly, the significance of human population ecology or human population biology, which aims to elucidate human adaptation at the population level not only in the short term, e.g. within a year, but also in the long term, e.g. through generations, had long been pointed out by many human ecologists and human biologists worldwide, but its systematic studies had been lacked. For this purpose, my efforts were devoted to the collaborative research in the Gidra-speaking popu-

Table 1. The major research items, broken down into four periods

	1st (-1992)	2nd (1990s)	3rd (current)	4th (future)
Establishment of research framework	++			
Developments/Innovations of methodologies*				
Human activity	+		+	(?)
Nutritional/health status	++	+	+	(?)
Energy expenditure	+	++	+	(?)
Microdemography	++			(?)
Specific themes**				
Infectious diseases	+	++	+	+
Toxic elements		+	++	+
Lifestyle-related diseases		+	+	++
Harmonized development			+	++

* Including only fieldwork-based methodologies.

** The common themes are not included.

Infectious diseases: mostly, malaria in the earlier stages and schistosomiasis in the later stages.

Toxic elements: mostly, mercury in the 2nd period and arsenic in the 3rd and 4th periods.

Lifestyle-related diseases: mostly, obesity, hypertension and cardiovascular disorders.

lation in Papua New Guinea. The Gidra people are suited to this purpose since they have maintained the basic characteristics of a population, forming a unit of marriages and thus a unit of gene pool, despite the small number, i.e. about 2,000 in total, but their microenvironmental conditions differ from village to village, e.g. inland, riverine and coastal terrains from the natural settings and in the degree of modernization from the sociocultural settings.

Our Gidra studies were characterized by the following two points. First, long-term field investigations were repeatedly conducted, based on observation, measurements and interviews, for the people's daily activity pattern, especially food procurements and intakes, nutritional and health status and population dynamics. Second, biological specimens (blood, urine and hair) and environmental samples (foods and water) were systematically collected for laboratory analyses.

In tandem with the establishment of the research framework, my efforts were directed to the developments and innovations of various biological, behavioral and microdemographic methods applicable to field investigations. The major achievements included 1) genealogical-demographic analysis which has been useful for reconstruction of long-term change in fertility, mortality and increase rates, 2) heart rate-monitoring method for estimation of energy expenditure which has now become popular in human ecological fieldworks and 3) determination of sodium, potassium and urea nitrogen concentrations from urine samples, using filter papers, which has also been widely used.

Following the findings from the Gidra studies, most of which were based on the combined efforts of fieldwork and laboratory analysis, more than 40 original papers were published in international journals. In addition, I, with Professor T. Suzuki, collected the

important papers to edit a book in English, titled *Population Ecology of Human Survival: Bioecological Studies of the Gidra in Papua New Guinea* (No. 15 in Select Publications), which has been distributed worldwide to not only human ecologists but also scientists in the related fields. The 20 chapters of this book are categorized into four parts: "The ecology of food production," "The ecology of food consumption," "Nutrition and health" and "Population structure and dynamics." Among various findings, some contributed to the health promotion plans of the national and provincial governments of Papua New Guinea: for instance, disadvantageous effects of dietary modernization due to reduced intakes of essential micronutrients (e.g. zinc and potassium) and less effects of iron supplementation to the anemia patients in malaria endemic areas because their anemic states were caused not by inadequate iron intake but by malaria-induced haemolysis and dyserythropoiesis.

Since the late 1980s, I have increased the study populations for more generalized understanding of the people's health and survival, based on the research framework which was established. For instance, our studies revealed an extraordinarily high mercury levels (in hair) among the Lake Murry population under artificially nonpolluted environment due to large consumed amounts of fish in which mercury was accumulated through biological concentration. For another instance, our studies in the most modernized rural population, called Balopa, disclosed that their prevalence rates of obesity and hypertension were higher than those in many other populations even in developed countries, mostly due to their less energy-consuming activity pattern and large amounts of intake of fat-rich purchased foods.

Aside from the studies in Papua New Guinea, both field research and toxicological and nutritional experiments were conducted for various Japanese popula-

tions, though only a few of them are listed in the Select Publications.

Current Research

Since the late 1990s, my research foci have extended to clarify the effects of modernization on human health and survival on the one hand, and on the other, the effects of some specific harmful environmental factors on human health and their mitigations.

In Papua New Guinea, our major efforts have been devoted to the comparative analysis of rural (homeland) dwellers and rural-urban migrants of the same populations, particularly the Huli and the Balopa, whose genetic backgrounds markedly differ. For this purpose, we have conducted research in both environments, the homelands and Port Moresby, i.e. the capital city, focusing on energy and nutrient intakes, energy expenditure and the prevalence of obesity, hypertension and other cardiovascular diseases and have disclosed the significance of lifestyle change on them; protein status has been improved while obesity, hypertension and many other cardiovascular risks have been worsened. Furthermore, the comparison between the two rural-urban migrant populations in Port Moresby revealed difference in the trigger factor, obesity for the Balopa (an Austronesian group) and high lipoprotein-a level for the Huli (a Non-Austronesian group).

Concurrently, I began research projects in several Asian countries. Of them, the study for Bangladeshi populations under arsenic hazards has been the major target in the last several years. Despite that 35-50 million Bangladeshi people are recognized as a risk population of arsenic poisoning, systematic analyses, the dose-response relationships in particular, have seldom been conducted. Our research contributed to concrete elucidation for the interrelations among arsenic concentration of drinking water, urinary arsenic concentration and the extents of skin lesions (i.e. keratosis and melanosis as the major symptoms of arsenic poisoning), in collaboration with dermatologists in our University Hospital. Furthermore, in this research project headed by me, many colleagues of different disciplines, such as water chemists and public health engineers from Switzerland and Japan and hydrologists from USA, have collaborated to seek integrated ways for mitigation of arsenic hazards and sustainable water supply systems in arsenic affected areas.

Energetics, i.e. the balance between energy intake and energy expenditure, has been one of the important research themes in our department. The recent studies have clarified its particularly significant roles on degradation of health status in modernization process among populations in Papua New Guinea, Thailand and Bangladesh.

Finally, I began a biosocial research, which seeks harmonized ways of community development and environmental conservation in the Asia-Oceania region. The major reason why I organized this project came from my judgment that the basic idea of human ecology is useful for this issue. In this project, I recruited not only biomedical scientists but rather sociocultural scientists from Japan and some other Asian and Oceanian countries. At the beginning stage, our findings have still been limited mostly due to difficulties in data collection by means of sociocultural methods, but I will continue this research in the future.

Future Prospects

My term of professor is not long, and thus I will concentrate in the three research projects: the arsenic hazards in Asian countries (not only Bangladesh but several countries) and the harmonized community development with environmental conservation in the Asia-Oceania region, both which have already commenced, and a new project which has begun in the year 2002 and will continue for three years. This new project aims to elucidate the causes of markedly different prevalence of lifestyle-related diseases among Asian, Melanesian and Polynesian populations. Based on my previous research findings and in collaboration with the staff in our school, particularly those from Department of Human Genetics (headed by Professor K. Tokunaga), the effects of both genetic factors and environmental (mostly lifestyle) factors will be simultaneously clarified.

My intentions for these three projects, with special interest in collaborations with scientists of other disciplines, are as follows. The arsenic project, which has been and will be sponsored by the Alliance for Global Sustainability (the joint programs of Massachusetts Institute of Technology in USA, Swiss Federal University of Technology and our university), is expected to contribute our human ecology research to the integrated efforts for solution/mitigation of this environmental issue, recognized very serious for human health and survival in several Asian countries. The genetical-ecological project for lifestyle-related diseases aims at development of collaborative works with many colleagues, particularly, those from Departments of Human Genetics, Biomedical Chemistry and Developmental Medical Sciences (all of which belong to a large Department called International Biomedical Sciences, together with our department). The harmonized development project is expected to broaden human ecology aspects through collaboration with scientists of social medicine and social ecology in our school, i.e. a large Department of International Social Medicine) and some others.

Research Grants

1. (as the Cluster Sub-leader, with many colleagues from many countries) "People, land management and environmental change" organized by the United Nations University and sponsored by the Global Environmental Facility through the United Nations Environmental Programme: 1998-99; 7,816,860 Yen (in total, for my own team).
2. (as the Leader, with 15 colleagues from Japan, USA, Switzerland, Bangladesh and Nepal) "Mitigation of groundwater-derived arsenic hazards and sustainable water supply system in Asian countries" sponsored by the Alliance for Global Sustainability Programs; 1999-2002; 29,420,518 Yen (in total).
3. (as the Leader, with 30 colleagues from Japan, China, Solomon Islands and Nepal) "Influences of development on local communities and their mitigations" sponsored by the Japan Society for Promotion of Science; 1999-2002; 184,000,000 Yen (in total).
4. (as the Leader, with 15 colleagues from Japan, Solomon Islands and Indonesia) "Genetico-ecological studies for high risks of lifestyle-related diseases in Oceanian populations" sponsored by the Monbukagakaku-sho, Japan (Grant-in-Aid for Scientific Research); 2002- 2004; 29,300,000 Yen (in total).
5. (as the Leader, with 10 colleagues from Japan, Papua New Guinea, Malaysia and Nepal) "Application of high-quality satellite images to analyses of land use and environmental change" sponsored by the Monbukagakaku-sho, Japan (Grant-in-Aid for Scientific Research); 2002-2005; 15,800,000 Yen (in total).

Select Publications

1. Ohtsuka R. *Oriomo Papuans: Ecology of Sago-Eaters in Lowland Papua*. University of Tokyo Press, Tokyo, 1983.
2. Ohtsuka R, Kawabe T, Inaoka T, Suzuki T, Hongo T, Akimichi T, Sugahara T. Composition of local and purchased foods consumed by the Gidra in lowland Papua. *Ecology of Food and Nutrition*, 15, 159-169, 1984.
3. Ohtsuka R, Kawabe T, Inaoka T, Akimichi T, Suzuki T. Inter- and intra-population migration of the Gidra in lowland Papua. *Human Biology*, 57, 33-45, 1985.
4. Ohtsuka R, Inaoka T, Kawabe T, Suzuki T, Hongo T, Akimichi T. Diversity and change of food consumption and nutrient intake among the Gidra in lowland Papua. *Ecology of Food and Nutrition*, 16, 339-350, 1985.
5. Kawabe T, Ohtsuka R, Inaoka T, Akimichi T, Suzuki T. Visual acuity of the Gidra in lowland Papua New Guinea. *Journal of Biosocial Science*, 17, 361-369, 1985.
6. Ohtsuka R, Hongo T, Kawabe T, Suzuki T, Inaoka T, Akimichi T, Sasano H. Mineral content of drinking water in lowland Papua. *Environment International*, 11, 505-508, 1985.
7. Ohtsuka R. Low rate of population increase of the Gidra Papuans in the past: A genealogical-demographic analysis. *American Journal of Physical Anthropology*, 71, 13-23, 1986.
8. Inaoka T, Suzuki T, Ohtsuka R, Kawabe T, Akimichi T, Takemori K, Sasaki N. Salt consumption, body fatness and blood pressure of the Gidra in lowland Papua. *Ecology of Food and Nutrition*, 20, 55-66, 1987.
9. Suzuki T, Ohtsuka R. [Eds.] *Human Ecology of Health and Survival in Asia and the South Pacific*. University of Tokyo Press, Tokyo, 1987.
10. Ohtsuka R, Suzuki T, Morita M. Sodium-rich tree ash as a native salt source in lowland Papua. *Economic Botany*, 41, 55-59, 1987.
11. Suzuki T, Watanabe S, Hongo T, Kawabe T, Inaoka T, Ohtsuka R, Akimichi T. Mercury in scalp hair of Papuans in the Fly estuary, Papua New Guinea. *Asia-Pacific Journal of Public Health*, 2, 39-47, 1988.
12. Ohtsuka, R. Hunting activity and aging among the Gidra Papuans: A biobehavioral analysis. *American Journal of Physical Anthropology*, 79, 31-39, 1989.
13. Hongo T, Suzuki T, Ohtsuka R, Kawabe T, Inaoka T, Akimichi T. Element intake of the Gidra in lowland Papua: Inter-village variation and the comparison with contemporary levels in developed countries. *Ecology of Food and Nutrition*, 23, 293-309, 1989.
14. Hongo T, Suzuki T, Ohtsuka R, Kawabe T, Inaoka T, Akimichi T. Hair element concentrations of the Gidra in lowland Papua: The comparison with dietary element intakes and water element concentrations. *Ecology of Food and Nutrition*, 24, 167-179, 1990.
15. Ohtsuka R, Suzuki T. [Eds.] *Population Ecology of Human Survival: Bioecological Studies of the Gidra in Papua New Guinea*. University of Tokyo Press, Tokyo, 1990.
16. Yoshinaga J, Minagawa M, Suzuki T, Ohtsuka R, Kawabe T, Hongo T, Inaoka T, Akimichi T. Carbon and nitrogen isotopic characterization for Papua New Guinea foods. *Ecology of Food and Nutrition*, 26, 17-25, 1991.
17. Yoshinaga J, Suzuki T, Ohtsuka R, Kawabe T, Hongo T, Imai H, Inaoka T, Akimichi T. Dietary selenium intake of the Gidra, Papua New Guinea. *Ecology of Food and Nutrition*, 26, 27-36, 1991.
18. Yoshinaga J, Suzuki T, Hongo T, Minagawa M, Ohtsuka R, Kawabe T, Inaoka T, Akimichi T. Mercury concentration correlates with the nitrogen stable isotope ratio in the animal food of Papuans. *Ecotoxicology and Environmental Safety*, 24, 37-45, 1992.
19. Hongo T, Ohtsuka R, Nakazawa M, Kawabe T, Inaoka T, Akimichi T, Suzuki T. Serum mineral and trace element concentrations in the Gidra of lowland Papua New Guinea: Inter-village variation and comparison with the levels in developed countries. *Ecology of Food and Nutrition*, 29, 307-318, 1993.
20. Hongo T, Abe T, Ohtsuka R, Komai M, Okiyama T, Amano K, Toyo-oka T, Suzuki T. Urinary mercury

- monitoring of university staff and students occasionally exposed to mercury vapor. *Industrial Health*, 32, 17-27, 1994.
21. Ohtsuka R. Subsistence ecology and carrying capacity in two Papua New Guinea populations. *Journal of Biosocial Science*, 26, 395-407, 1994.
 22. Nakazawa M, Ohtsuka R, Kawabe T, Hongo T, Suzuki T, Inaoka T, Akimichi T, Kano S, Suzuki M. Differential malaria prevalence among villages of the Gidra in lowland Papua New Guinea. *Tropical and Geographical Medicine*, 46, 350-354, 1994.
 23. Hongo T, Ohtsuka R, Inaoka T, Kawabe T, Akimichi T, Kuchikura Y, Suda K, Tohyama C, Suzuki T. Health status comparison by urinalysis (dipstick test) among four populations in Papua New Guinea. *Asia-Pacific Journal of Public Health*, 7, 165-172, 1994.
 24. Yoshida M, Ohtsuka R, Nakazawa M, Juji T, Tokunaga K. HLA-DRB1 frequencies of Non-Austronesian-speaking Gidra in south New Guinea and their genetic affinities with Oceanian populations. *American Journal of Physical Anthropology*, 96, 177-181, 1995.
 25. Ohtsuka R, Inaoka T, Umezaki M, Nakada N, Abe T. Long-term subsistence adaptation to the diversified Papua New Guinea environment: Human ecological assessments and prospects. *Global Environmental Change*, 5, 347-353, 1995.
 26. Abe T, Ohtsuka R, Hongo T, Suzuki T, Tohyama C, Nakano A, Akagi H, Akimichi T. High hair and urinary mercury levels of fish eaters in the nonpolluted environment of Papua New Guinea. *Archives of Environmental Health*, 50, 367-373, 1995.
 27. Yoshinaga J, Minagawa M, Suzuki T, Ohtsuka R, Kawabe T, Inaoka T, Akimichi T. Stable carbon and nitrogen isotopic composition of diet and hair of Gidra-speaking Papuans. *American Journal of Physical Anthropology*, 100, 23-34, 1996.
 28. Dejima Y, Fukuda S, Ichijoh Y, Takasaka K, Ohtsuka R. Cold-induced salt intake in mice and catecholamine, renin and thermogenesis mechanisms. *Appetite*, 26, 203-220, 1996.
 29. Nakazawa M, Ohtsuka R, Kawabe T, Hongo T, Inaoka T, Akimichi T, Suzuki T. Iron nutrition and anaemia in a malaria-endemic environment: Haematological investigation of the Gidra-speaking population in lowland Papua New Guinea. *British Journal of Nutrition*, 76, 333-346, 1996.
 30. Inaoka T, Ohtsuka R, Kawabe T, Hongo T, Suzuki T. Emergence of degenerative diseases in Papua New Guinea islanders. *Environmental Sciences*, 4, 79-93, 1996.
 31. Nakazawa M, Ohtsuka R. Analysis of completed parity using microsimulation modeling. *Mathematical Population Studies*, 6, 173-186, 1997.
 32. Umezaki M, Ohtsuka R. Impact of rural-urban migration on fertility: A population ecology analysis in the Kombio, Papua New Guinea. *Journal of Biosocial Science*, 30, 411-422, 1998.
 33. Ohtsuka R, Abe T, Umezaki M. *Environmentally Sound Agricultural Development in Rural Societies: A Comparative View from Papua New Guinea and South China*. UNESCO, Paris, 1998.
 34. Sudo N, Ohtsuka R. Sleep patterns and sleep disorders among female shift workers in a computer factory of Japan. *Journal of Human Ergology*, 28, 39-47, 1999.
 35. Umezaki M, Ishimaru H, Ohtsuka R. Daily time budgets of long-distance commuting workers in Tokyo Megalopolis. *Journal of Biosocial Science*, 31, 71-78, 1999.
 36. Murayama N, Ohtsuka R. Seasonal fluctuation in energy balance among farmers in Northeast Thailand: The lack of response of energy intake to the change of energy expenditure. *European Journal of Clinical Nutrition*, 53, 39-49, 1999.
 37. Umezaki M, Yamauchi T, Ohtsuka R. Diet among the Huli in Papua New Guinea Highlands when they were influenced by the extended rainy period. *Ecology of Food and Nutrition*, 37, 409-427, 1999.
 38. Murayama N, Ohtsuka R. Heart rate indicators for assessing physical activity level in the field. *American Journal of Human Biology*, 11, 647-657, 1999.
 39. Natsuhara K, Inaoka T, Umezaki M, Yamauchi T, Hongo T, Nagano M, Ohtsuka R. Cardiovascular risk factors of migrants in Port Moresby from the highlands and island villages, Papua New Guinea. *American Journal of Human Biology*, 12, 655-664, 2000.
 40. Nakazawa M, Ohtsuka R, Hongo T, Inaoka T, Kawabe T, Suzuki T. Serum biochemical data of the Gidra in lowland Papua New Guinea: Consideration of their normal ranges. *Journal of Nutrition and Environmental Medicine*, 10, 153-162, 2000.
 41. Ohashi J, Yoshida M, Ohtsuka R, Nakazawa M, Juji T, Tokunaga K. Analysis of HLA-DRB1 polymorphism in the Gidra of Papua New Guinea. *Human Biology*, 72, 337-347, 2000.
 42. Yamauchi T, Ohtsuka R. Basal metabolic rate and energy costs at rest and during exercise in rural- and urban-dwelling Papua New Guinea Highlanders. *European Journal of Clinical Nutrition*, 54, 494-499, 2000.
 43. Yamauchi T, Umezaki M, Ohtsuka R. Energy expenditure, physical exertion and time allocation among Huli-speaking people in the Papua New Guinea Highlands. *Annals of Human Biology*, 27, 571-585, 2000.
 44. Umezaki M, Kuchikura Y, Yamauchi T, Ohtsuka R. Impact of population pressure on food production: An analysis of land use change and subsistence pattern in the Tari basin in Papua New Guinea Highlands. *Human Ecology*, 28, 359-381, 2000.
 45. Yamauchi T, Umezaki M, Ohtsuka R. Influence of urbanisation on physical activity and dietary changes in Huli-speaking population: A comparative study of village dwellers and migrants in urban settlements. *British Journal of Nutrition*, 85, 65-73, 2001.

46. Yamauchi T, Umezaki M, Ohtsuka R. Physical activity and subsistence pattern of the Huli, a Papua New Guinea Highland population. *American Journal of Physical Anthropology*, 114, 258-268, 2001.
47. Umezaki M, Natsuhara K, Ohtsuka R. Protein content and amino acid scores of sweet potatoes in Papua New Guinea Highlands. *Ecology of Food and Nutrition*, 40, 471-480, 2001.
48. Watanabe C, Inaoka T, Kadono T, Nagano M, Nakamura S, Ushijima K, Murayama N, Miyazaki K, Ohtsuka R. Males in rural Bangladeshi communities are more susceptible to chronic arsenic poisoning than females: Analyses based on urinary arsenic. *Environmental Health Perspectives*, 109, 1265-1270, 2001.
49. Sudo N, Ohtsuka R. Nutrient intake among female shift workers in a computer factory in Japan. *International Journal of Food Sciences and Nutrition*, 52, 367-378, 2001.
50. Umezaki M, Yamauchi T, Ohtsuka R. Time allocation to subsistence activities among the Huli in rural and urban Papua New Guinea. *Journal of Biosocial Science*, 34, 133-137, 2002.

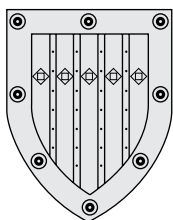

Department of Biomedical Chemistry

Outline and Research Objectives

Aim of our department is to contribute to global health and welfare from basic research. Our department, formerly named Biochemistry and Nutrition was renamed on April 1st, 1996 to The Department of Biomedical Chemistry as newly affiliating with Biomedical Science Division of International Health, Graduate School of Medicine, The University of Tokyo. Prof. Kita has moved from The Institute of Medical Science, The University of Tokyo on March 1st, 1998. Therefore, we are quite new and all of our members are highly motivated.

Faculties and Students

Professor and Chair	KITA Kiyoshi, Dr. of Pharmacy (1998-)
Lecturer	WATANABE Yoh-ichi, Dr. of Technology
Associate	3
Postdoctoral Fellow	2
Graduate student	12
Research student.....	4
Secretary	1

Past Research and Major Accomplishments

Energy metabolism is essential for the survival, continued growth and reproduction of living organisms. From the standpoint of biological adaptation, we have been studying on the molecular mechanism of energy transducing systems such as mitochondrial and bacterial respiratory chain. Because energy metabolisms of pathogenic organisms such as bacteria and parasites are quite different from that of mammalian host and these unique aspects of pathogens would be promising targets for chemotherapy.

For the first step to understand a mechanism of adaptation to the change of oxygen availability, composition and its change during aerobic growth of *Escherichia coli* was studied. Finally, we found two different terminal oxidases, cytochrome *bo* and *bd* complexes. Cytochrome *bo* complex is expressed in early log phase and possesses proton-pumping activity, while cytochrome *bd* complex is expressed from late log phase to stationary phase with higher affinity to oxygen than cytochrome *bo* complex. Thus, we found that *E. coli* keep their energy supply by changing the respiratory chain during their growth.

Then, we have started our research on the biological strategy to adapt to different oxygen availability in eukaryotes. Purpose of this project is multiple. We

would like to know the common strategy to maintain energy supply in different environments and also to understand unique feature of energy metabolism in pathogenic organisms. If we could understand the mechanism clearly, it would be quite important information to fight against infectious diseases caused by bacteria and parasites in addition to the basic knowledge on the molecular mechanism of biological adaptation. As a model system, we selected *Ascaris suum* which is a parasitic nematode resides in our small intestine where oxygen tension is quite limited, because 1) they are rather large in size allowing biochemical study, 2) their life cycle has been well characterized and 3) they are closely related to *Caenorhabditis elegans* which is well known free-living nematode, of which whole genome sequence has been reported.

Current Research

I. Human mitochondria

- 1) succinate dehydrogenase
- 2) mitochondrial myopathy

Succinate-ubiquinone oxidoreductase (complex II and/or SQR) is an important enzyme complex in both the tricarboxylic acid cycle and the aerobic respiratory chains of eukaryotic mitochondria and prokaryotic cells. Complex II catalyzes the oxidation of succinate to fumarate (succinate dehydrogenase: SDH) and transfers its reducing equivalent to ubiquinone. To elucidate the molecular basis of a mitochondrial disease caused by a deficiency in the SDH activity of complex II, we cloned the cDNAs for all four subunits of human liver complex II. During this study, we found two isoforms of complex II containing Fp subunits of liver type and heart type.

Then we have mapped large (CybL) and small (CybS) subunits of cytochrome *b* in complex II of

human mitochondria to chromosome 1q21 and 11q23, respectively. Recently, the human *SDHD* gene encoding CybS was cloned and characterized. The gene comprises four exons and three introns extending over 19 kb. Sequence analysis of the 5' promoter region showed several motifs for the binding of transcription factors including nuclear respiratory factors NRF-1 and NRF-2 at positions -137 and -104, respectively. In addition to this gene, six pseudogenes of CybS were isolated and mapped on the chromosome.

II. *Ascaris suum* and *Caenorhabditis elegans*

- 1) molecular mechanism of adaptation to low oxygen tension (regulation of gene expression of mitochondrial proteins)
- 2) mitochondrial quinol-fumarate reductase (structure-function relationship, enzyme evolution)
- 3) *C. elegans* as a model system of parasitic nematodes and ageing (expression of foreign genes, gene knockout, oxygen stress)

Parasites have developed a variety of physiological functions necessary for existence within the specialized environment of the host. Regarding energy metabolism, which is an essential factor for survival, parasites adapt to low oxygen tension in host mammals using metabolic systems that are very different from that of the host. The majority of parasites does not use the oxygen available within the host, but employ systems other than oxidative phosphorylation for ATP synthesis.

In addition, all parasites have a life cycle. In many cases, the parasite employs aerobic metabolism during their free-living stage outside the host. In such systems, parasite mitochondria play diverse roles. In particular, marked changes in the morphology and components of the mitochondria during the life cycle are very interesting elements of biological processes such as developmental control and environmental adaptation. Recent our research on adult *A. suum* has shown that the stage-specific mitochondrial complex II plays an important role in the anaerobic energy metabolism of parasites inhabiting hosts, by acting as quinol-fumarate reductase (QFR). Sequence analysis of the subunits in the enzyme revealed that mitochondrial QFR is new enzyme evolved by "reverse evolution" of SQR rather than direct evolution from bacterial QFR.

We have been studying free-living nematode, *C. elegans* as a control nematode living in an aerobic condition. In addition, we also have been studying ageing by using *C. elegans*. Our study on long-lived *clk-1* mutants of *C. elegans* demonstrated that biosynthesis of UQ is dramatically altered in mutant mitochondria. Demethoxy ubiquinone (DMQ), that accumulates in *clk-1* mutants in place of UQ, may contribute to the extension of life span. We proposed the

possible mechanisms of life span extension in *clk-1* mutants, with particular emphasis on the electrochemical property of DMQ. On the other hand, in the short-lived *mev-1* mutant, a point of mutation glycine 71 of CybL in SQR results in hypersensitivity to oxidative stress. We demonstrated the production of reactive oxygen species (ROS) was higher in the mutant complex II than wild type, indicating ROS is responsible for the short life span of *mev-1* mutant.

III. Malaria and Trypanosome (*Plasmodium falciparum*, *Trypanosoma brucei*, *Trypanosoma cruzi*)

- 1) characterization of mitochondria as a target for the chemotherapy
- 2) molecular biology of mitochondrial DNA
- 3) structure based drug design (SBDD)

The mitochondria of parasitic protozoa that have been most studied are those of *Trypanosoma brucei*, which is the causative agents of African trypanosomiasis in human and nagana in cattle. Parasitic protozoa living within a mammalian host do not generally use oxygen, and instead synthesize ATP via the glycolytic pathway. In comparison to research on helminthes, research on mitochondrial electron transfer of protozoa during the developmental stage within the host is lacking. However, mitochondria have become a focus of chemotherapy, and researches, particularly on mitochondria of the malaria parasite and trypanosomes are currently progressing.

To study the unique properties of *Plasmodium* complex II, we have cloned and characterized the genes for the flavoprotein subunit (Fp) and the iron-sulfur protein subunit (Ip) subunits of complex II. This is the first report of the primary structure of protozoan complex II. Interestingly, a *P. falciparum*-specific insertion and a unicellular organism-specific deletion were found in the amino acid sequence of Fp. Despite the fact that Fp and Ip are generally well-conserved subunits, the structure of both subunits in the malaria parasite clearly differs considerably from that of the host.

Cyanide-insensitive trypanosome alternative oxidase (TAO) is the terminal oxidase of the respiratory chain of long slender bloodstream forms of the African trypanosome. TAO is a cytochrome-independent, cyanide-insensitive quinol oxidase. These characteristics are distinct from those of the bacterial quinol oxidase, a protein that belongs to the heme-copper terminal oxidase superfamily. TAO has been targeted for the development of anti-trypanosomal drugs because it does not exist in the host. We found the most potent inhibitor of TAO to date, ascofuranone, a compound isolated from phytopathogenic fungus, *Ascochyta visiae*. The inability to purify stable TAO has severely hampered biochemical studies of the

alternative oxidase family. Recently, we were able to purify recombinant TAO to homogeneity from *E. coli* membranes using the detergent digitonin. Kinetic analysis of the purified TAO revealed that ascofuranone is a competitive inhibitor of ubiquinol oxidase activity.

IV. *Escherichia coli*

- 1) succinate dehydrogenase complex (mechanism of molecular assembly, electron transport mechanism in the complex)
- 2) regulation of energy supply

E. coli is one of the useful model systems to investigate biological reactions common to living organisms. In order to investigate the role of the heme in the assembly of complex II, we used a *hemH* (encodes ferrochelatase) mutant of *E. coli* lacking the ability to insert iron into the porphyrin ring. The *hemH* mutant failed to synthesize functional complex II in the cytoplasmic membrane and the catalytic portion of complex II, Fp and Ip, was localized in the cytoplasm of the cell. In contrast, complex II was assembled in the membrane of a heme-permeable and *hemH* double mutant when hemin was present in the culture. Only a small amount of succinate-ubiquinone reductase (SQR) activity was found in the membrane when hemin was replaced by non-iron metalloporphyrins; Mn-, Co-, Ni-, Zn-, Cu-protoporphyrin IX or protoporphyrin IX. These results indicate the indispensability of iron of heme for the functional assembly of complex II in the cytoplasmic membrane of *E. coli*, and add a new aspect to the biological role of heme in the molecular assembly of the multi-subunit enzyme complex.

Future Prospects

Dynamic rearrangement of the respiratory chain during parasite life cycle that we found is a key element of their adaptation to different environments. In the case of mammals, cells are able to sense decreased oxygen and activate response systems, including hypoxia-inducible factor-1 (HIF-1)-mediated transcriptional activation of several genes. Quite recently, HIF- β and a homologue of HIF-1 α were found in the free-living nematode *C. elegans*. Although it is not known whether such a pathway exists in the parasites, *A. suum* shows a very clear transition between larval and adult metabolic systems. Thus, *A. suum* is an excellent model system for studying the regulation of transcription by the oxygen level in the environment.

Current research on *C. elegans* including our result has revealed that oxygen concentration, its availability, and oxidative stress can produce a variety of inter-

esting phenotypes such as modified life spans. As described above, in the long-lived *C. elegans* mutant *clk-1*, UQ biosynthesis is altered so that mitochondria do not possess detectable levels of UQ-9 but instead contain the UQ biosynthesis intermediate DMQ-9. On the other hand, in the short-lived *mev-1* mutant, a point of mutation glycine 71 of CybL in SQR results in hypersensitivity to oxidative stress. These findings indicate that the respiratory chain plays an important role in sensing and responding to the oxygen level in the environment. Consistent with this, recent reports suggest that complex II functions as an oxygen sensor in human. We would like to understand a molecular mechanism of biological adaptation to the change of oxygen availability by using these nematodes and human systems. Diversity of complex II was also found in human complex II. Studies on the human respiratory chain will be achieved from the viewpoint of physiological role of energy supply and related diseases.

It remains unclear which critical factor determines the catalytic direction of electron transfer in complex II. Biochemical and molecular biological studies showed that both the properties and the primary structures of mitochondrial and bacterial quinol-fumarate reductase (QFR) differ significantly. Identification of the amino acid residues of mitochondrial QFR responsible for the directional specificity of its catalysis should help to clarify the molecular mechanism of this "new" parasite enzyme. Furthermore, investigations of the molecular pathways of parasite survival may provide insight into general mechanisms of biological adaptation.

Finally, we would like to develop anti-parasitic drugs which should be used in endemic areas. As described in "Current Research", the parasite metabolic system is an attractive target for chemotherapy because it is different than the host metabolic system and because it is essential for parasite survival. TAO in trypanosome mitochondria and its specific inhibitor, ascofuranone are excellent examples in this regard. As pointed out by Dr. Opperdoes, ascofuranone is the most potent TAO inhibitor to date. Because of its high selectivity and low toxicity, ascofuranone is a potential candidate for the next generation of anti-trypanosomal agents. Indeed, current studies are examining the molecular mechanism of ascofuranone and ways of improving its efficacy *in vivo*. We already have started a trial by using goat in Africa. One problem that must be solved is that glycerol must be administered along with ascofuranone, to inhibit the reverse reaction of glycerol kinase. Although glycerol is not toxic, it is not practical to give the large dose (3g /kg) required, and an inhibitor of the reverse reaction of glycerol kinase is expected to be more useful. Fortunately, glycerol kinase has

been cloned and the recombinant enzyme can be over-expressed. We are now trying to screen and find a specific inhibitor of glycerol kinase.

Thus, we would like to contribute to global health and welfare from basic research and train young scientists to be thoughtful and powerful colleagues.

Research Grants

1. "Molecular and biochemical studies on *Plasmodium* mitochondria" from a Grant-in-aid for scientific research on priority areas from the Ministry of Education, Science, Culture and Sport, Japan 40,000,000 yen (2001-)
2. "Crystalization of parasite proteins and molecular design of anti-parasitic drugs" from Pilot Applied Research Project for the Industrial Use of Space" of the National Space Development Agency of Japan (NASDA) and Japan Space Utilization Promotion Center (JSUP). 30,000,000 yen (2000-)
3. "New anti-trypanosome drug, ascofuranone" from a Grant for research on emerging and re-emerging infectious diseases from the Ministry of Health and Welfare 120,000,000 yen (1999-2001)
4. "Molecular structure and role of mitochondrial fumarate reductase from *Ascaris suum*" from a Grant-in-aid for scientific research on priority areas from the Ministry of Education, Science, Culture and Sport, Japan 13,200,000 yen (1999-2000)
5. "Molecular properties of *Plasmodium* mitochondria in the erythrocytic stages" from a Grant-in-aid for scientific research on priority areas from the Ministry of Education, Science, Culture and Sport, Japan 28,000,000 yen (1997-2000)

Select Publications

1. Kita, K., Yamato, I., and Anraku, Y. Purification and properties of cytochrome *b556* in the respiratory chain of aerobically grown *Escherichia coli* K12. *J. Biol. Chem.* 253, 8910-8915, 1978.
2. Kita, K., Kasahara, M., and Anraku, Y. Formation of a membrane potential by reconstituted liposomes made with cytochrome *b562-o* complex, a terminal oxidase of *Escherichia coli* K12. *J. Biol. Chem.* 257, 7933-7935, 1982.
3. Kita, K., Konishi, K., and Anraku, Y. Terminal oxidases of *Escherichia coli* aerobic respiratory chain. I. Purification and properties of cytochrome *b562-o* complex from cells in the early exponential phase of aerobic growth. *J. Biol. Chem.* 259, 3368-3374, 1984, II. Kita, K., Konishi, K., and Anraku, Y. Purification and properties of cytochrome *b558-d* complex from cells grown with limited oxygen and evidence of branched electron carrying systems. *J. Biol. Chem.* 259, 3375-3381, 1984.

4. Kita, K., Takamiya, S., Furushima, R., Ma, Y., and Oya, H. Complex II is a major component of the respiratory chain in the muscle mitochondria of *Ascaris suum* with high fumarate reductase activity. *Comp. Biochem. Physiol.* 89, 31-34, 1988.
5. Kita, K., Takamiya, S., Furushima, R., Ma, Y., Suzuki, H., Ozawa, T., and Oya, H. Electron-transfer complex of *Ascaris suum* muscle mitochondria. III. Composition and fumarate reductase activity of complex II. *Biochim. Biophys. Acta* 935, 130-140, 1988.
6. Hata-Tanaka, A., Kita, K., Furushima, R., Oya, H., and Itoh, S. ESR studies on iron-sulfur clusters of complex II in *Ascaris suum* mitochondria which exhibits strong fumarate reductase activity. *FEBS Lett.* 242, 183-186, 1988.
7. Kita, K., Vibat, C., Meinhardt, S., Guest, J., and Gennis, R. One-step purification from *Escherichia coli* of complex II (succinate-ubiquinone oxidoreductase) associated with succinate reducible cytochrome *b₅₅₆*. *J. Biol. Chem.* 264, 2672-2677, 1989.
8. Kita, K., Oya, H., Gennis, R., Ackrell, B.A.C., and Kasahara, M. Human complex II (succinate-ubiquinone oxidoreductase): cDNA cloning of iron sulfur (Ip) subunit of liver mitochondria. *Biochem. Biophys. Res. Commun.* 166, 101-108, 1990.
9. Furushima, R., Takamiya, S., Okochi, I., Kita, K., Aoki, T., and Oya, H. A comparative study of the effects of phebrrol on the respiratory chains of rat liver, *Biomphalaria glabrata* and *Oncomelania nosophora*. *Comp. Biochem. Physiol.* 99C, 191-199, 1991.
10. Kita, K. Electron-transfer complexes of mitochondria in *Ascaris suum*. *Parasitol. Today* 8, 155-159, 1992.
11. Hirawake, H., Wang, H., Kuramochi, T., Kojima, S., and Kita, K. Human Complex II (succinate-ubiquinone oxidoreductase): cDNA cloning of the flavoprotein (Fp) subunit of liver mitochondria. *J. Biochem.* 116, 221-227, 1994.
12. Kuramochi, T., Hirawake, H., Kojima, S., Takamiya, S., Furushima, R., Aoki, T., Komuniecki, R., and Kita, K. Sequence comparison between the flavoprotein subunit of the fumarate reductase (Complex II) of the anaerobic parasitic nematode, *Ascaris suum* and the succinate dehydrogenase of the aerobic, free-living nematode, *Caenorhabditis elegans*. *Mol. Biochem. Parasitol.* 68, 177-187, 1994.
13. Watanabe, Y., Tsurui, H., Ueda, T., Furushima, R., Takamiya, S., Kita, K., Nishikawa, K., and Watanabe, K. Primary and higher order structures of nematode (*Ascaris suum*) mitochondrial tRNAs lacking either the T or D stem. *J. Biol. Chem.* 269, 22902-22906, 1994.
14. Saruta, F., Kuramochi, T., Nakamura, K., Takamiya, S., Yu, Y., Aoki, T., Sekimizu, K., Kojima, S., and Kita, K. Stage-specific isoforms of Complex II (succinate-ubiquinone oxidoreductase) in mitochondria from the parasitic nematode, *Ascaris suum*. *J. Biol. Chem.* 270, 928-932, 1995.
15. Kuramochi, T., Kita, K., Takamiya, S., Kojima, S., and Hayasaki, M. Comparative study and cDNA cloning

- of the flavoprotein subunit of mitochondrial complex II (succinate-ubiquinone oxidoreductase: fumarate reductase) from the dog heartworm, *Dirofilaria immitis*. *Comp. Biochem. Physiol.* 111B, 491-502, 1995.
16. Nakamura, K., Yamaki, M., Sarada, M., Nakayama, S., Vibat, C.R.T., Gennis, R.B., Nakayashiki, T., Inokuchi, H., Kojima, S., and Kita, K. Two hydrophobic subunits are essential for the heme b ligation and functional assembly of complex II (succinate-ubiquinone oxidoreductase) from *Escherichia coli*. *J. Biol. Chem.* 271, 521-527, 1996.
 17. Takamiya, S., Hirawake, H., Kuramochi, T., Aoki, T., Kojima, S., and Kita, K. cDNA cloning for mitochondrial cytochrome c and its adult-specific isoform from *Ascaris suum*. *Mol. Biochem. Parasitol.* 76, 293-297, 1996.
 18. Ohtsuki, T., Kawai, G., Watanabe, Y., Kita, K., Nishikawa, K., and Watanabe, K. Preparation of biologically active *Ascaris suum* mitochondrial tRNA^{Met} with a TV-replacement loop by ligation of chemically synthesized RNA fragments. *Nucleic Acids Res.* 24, 662-667, 1996.
 19. Noor Rain, A., Furuta, T., Radzan, T., Kita, K., Kojima, S., and Mak, J.W. Development of a new diagnostic method for *Plasmodium falciparum* infection using a reverse transcriptase-polymerase chain reaction. *Am. J. Trop. Med. Hyg.* 54, 162-163, 1996.
 20. Saruta, F., Hirawake, H., Takamiya, S., Ma, Y-C., Aoki, T., Sekimizu, K., Kojima, S., and Kita, K. Cloning of a cDNA encoding the small subunit of cytochrome b₅₅₈ (cybS) of mitochondrial fumarate reductase (Complex II) from adult *Ascaris suum*. *Biochim. Biophys. Acta* 1276, 1-5, 1996.
 21. Minagawa, N., Yabu, Y., Kita, K., Ohta, N., Meguro, K., Sakajo, S., and Yoshimoto, A. An antibiotic, Ascofuranone, specifically inhibits respiration and *in vitro* growth of long slender bloodstream forms of *Trypanosoma brucei brucei*. *Mol. Biochem. Parasitol.* 81, 127-136, 1996.
 22. Lim, P.K.C., Watanabe, Y., Tan, S.K., Furuta, T., Aoki, T., Kojima, S., Kita, K., Sharma, Y.D., and Mak, J.W. Cytochrome c oxidase III (COIII) gene of *Plasmodium vivax*: Complete coding sequence and its expression in the erythrocytic stage of the parasite. *Jpn. J. Parasitol.* 45, 373-383, 1997.
 23. Nara, T., Tanabe, K., Mahakunkijcharoen, Y., Osada, Y., Matsumoto, N., Kita, K., and Kojima, S. The B cell epitope of paramyosin recognized by a protective monoclonal IgE antibody to *Schistosoma japonicum*. *Vaccine* 15, 79-84, 1997.
 24. Watanabe, Y., Tsurui, H., Ueda, T., Furushima, R., Takamiya, S., Kita, K., Nishikawa, K., and Watanabe, K. Primary sequence of mitochondrial tRNA^{Arg} of a nematode *Ascaris suum*: occurrence of unmodified adenosine at the first position of the anticodon. *Biochim. Biophys. Acta* 1350, 119-122, 1997.
 25. Kita, K., Hirawake, H., and Takamiya, S. Cytochromes in the respiratory chain of helminth mitochondria. *Int. J. Parasitol.* 27, 617-630, 1997.
 26. Hirawake, H., Kita, K., and Sharma, Y.D. Variation in the C-terminal repeats of the knob-associated histidine-rich protein of *Plasmodium falciparum*. *Biochim. Biophys. Acta* 1360, 105-108, 1997.
 27. Isobe, K., Kishino, S., Inoue, K., Takai, D., Hirawake, H., Kita, K., Miyabayashi, S., and Hayashi, J. Identification of inheritance modes of mitochondrial diseases by introduction of pure nuclei from mtDNA-less HeLa cells to patient-derived fibroblasts. *J. Biol. Chem.* 272, 12606-12610, 1997.
 28. Watanabe, Y., Kita, K., Ueda, T., and Watanabe, K. cDNA sequence of a translational elongation factor Ts homologue from *Caenorhabditis elegans*: mitochondrial factor-specific features found in the nematode homologue peptide. *Biochim. Biophys. Acta* 1353, 7-12, 1997.
 29. Hirawake, H., Taniwaki, M., Tamura, A., Kojima, S., and Kita, K. Cytochrome b in human complex II (succinate-ubiquinone oxidoreductase): cDNA cloning of the components in liver mitochondria and chromosome assignment of the genes for the large (SDHC) and small (SDHD) subunits to 1q21 and 11q23. *Cytogenet. Cell Genet.* 79, 132-138, 1997.
 30. Vibat, C.R.T., Cecchini, G., Nakamura, K., Kita, K., and Gennis, R.B. Localization of histidine residues responsible for heme axial ligation in cytochrome b₅₅₆ of complex II (succinate:ubiquinone oxidoreductase) in *Escherichia coli*. *Biochemistry* 37, 4148-4159, 1998.
 31. Fukai, Y., Amino, H., Hirawake, H., Yabu, Y., Ohta, N., Minagawa, N., Sakajo, S., Yoshimoto, A., Nagai, K., Takamiya, S., Kojima, S., and Kita, K. Functional expression of the ascofuranone-sensitive *Trypanosoma brucei brucei* alternative oxidase in the cytoplasmic membrane of *Escherichia coli*. *Comp. Biochem. Physiol.* 124, 141-148, 1999.
 32. Hirawake, H., Taniwaki, M., Tamura, A., Amino, H., Tomitsuka, A., and Kita, K. Characterization of the human SDHD gene encoding the small subunit of cytochrome b (cybS) in mitochondrial succinate-ubiquinone oxidoreductase. *Biochim. Biophys. Acta* 1412, 295-300, 1999.
 33. Amino, H., Wang, H., Hirawake, H., Saruta, F., Mizuchi, D., Mineki, R., Shindo, N., Murayama, K., Takamiya, S., Aoki, T., Kojima, S., and Kita, K. Stage-specific isoforms of *Ascaris suum* complex II: the fumarate reductase of the parasitic adult and the succinate dehydrogenase of free-living larvae share a common iron-sulfur subunit. *Mol. Biochem. Parasitol.* 106, 63-76, 2000.
 34. Takeo, S., Kokaze, A., Ng, C. S., Mizuchi, D., Watanabe, J., Tanabe, K., Kojima, S., and Kita, K. Succinate dehydrogenase in *Plasmodium falciparum* mitochondria: Molecular characterization of the SDHA and SDHB genes for the catalytic subunits, the flavoprotein (Fp) and iron-sulfur (Ip) subunits. *Mol. Biochem. Parasitol.* 107, 191-205, 2000.
 35. Omura, S., Miyadera, H., Ui, H., Shiomi, K., Yamaguchi, Y., Masuma, R., Nagamitsu, T., Iwai, Y., Takano, D., Sunazuka, T., Harder, A., Klbl, H.,

- Namikoshi, M., Miyoshi, H., Sakamoto, K., and Kita, K. An anthelmintic compound nafuredin shows selective inhibition of complex I in helminth mitochondria. *Proc. Natl. Acad. Sci. USA*, 98, 60-62, 2001.
36. Nihei, C., Nakayashiki, T., Nakamura, K., Inokuchi, H., Gennis, R. B., Kojima, S., and Kita, K. Abortive Assembly of Succinate-Ubiquinone Reductase (Complex II) in a Ferrochelatase-deficient Mutant of *Escherichia coli*. *Mol. Genet. Genomics*. 265, 394-404, 2001.
 37. Miyadera, H., Amino, H., Hiraishi, A., Taka, H., Murayama, M., Miyoshi, H., Sakamoto, K., Ishii, N., Hekimi, S., Kita, K. Altered quinone biosynthesis in the long-lived *clk-1* mutants of *Caenorhabditis elegans*. *J. Biol. Chem.*, 276, 7713-7716, 2001.
 38. Ohtsuki, T., Watanabe, Y., Takemoto, C., Kawai, G., Ueda, T., Kita, K., Kojima, S., Kaziro, Y., Nyborg, J., and Watanabe, K. An "Elongated" translation elongation factor Tu for truncated tRNAs in nematode mitochondria. *J. Biol. Chem.* 276, 21571-21577, 2001.
 39. Takashima, E., Takamiya, S., Takeo, S., Mi-ichi, F., Amino, H. and Kita, K. Isolation of mitochondria from *Plasmodium falciparum* showing dihydroorotate dependent respiration. *Parasitol. Int.* 50, 273-278, 2001.
 40. Ishii, N., Kita, K. and Hartman, P. S. Mitochondrial contributions to aging in the nematode *Caenorhabditis elegans*. *Current Genomics* 2, 349-355, 2001.
 41. Matsuzaki, M., Kikuchi, T., Kita, K., Kojima, S., and Kuroiwa, T. Large amount of apicoplast nucleoid DNA and its segregation in *Toxoplasma gondii*. *Protoplasma*, 218, 180-191, 2001.
 42. Levavasseur, F., Miyadera, H., Sirois, J., Tremblay, M., Kita, K., Shoubbridge, E. and Hekimi, S. Ubiquinone is necessary for mouse embryonic development but is not essential for mitochondrial respiration. *J. Biol. Chem.* 276, 46160-46164, 2001.
 43. Kita, K., Hirawake, H., Miyadera, H., Amino, H., and Takeo, S. Role of complex II in anaerobic respiration of the parasite mitochondria from *Ascaris suum* and *Plasmodium falciparum*. *Biochim. Biophys. Acta*, 1553, 123-139, 2002.
 44. Nihei, C., Fukai, Y. and Kita, K. Trypanosome Alternative Oxidase as a Target of Chemotherapy. *Biochim. Biophys. Acta*, 1587, 234-239, 2002.
 45. Watanabe, Y., Yokobori, S., Inaba, T., Yamagishi, A., Oshima, T., Kawarabayasi, Y., Kikuchi, H. and Kita, K. Introns in protein-coding genes in Archaea. *FEBS Lett.* 510, 27-30, 2002.
 46. Miyadera, H., Kano, K., Miyoshi, H., Ishii, N., Hekimi, S. and Kita, K. Quinones in long-lived *clk-1* mutants of *Caenorhabditis elegans*. *FEBS Lett.* 512, 33-37, 2002.
 47. Kita, K., and Takamiya, S. Electron transfer complexes in *Ascaris* mitochondria. *Advance in Parasitology*. 51, 95-131, 2002.
 48. Fukai, Y., Nihei, C., Yabu, Y., Suzuki, T., Ohta, N., Minagawa, N., Nagai, K. and Kita, K. Strain-specific difference in amino acid sequences of Trypanosome Alternative Oxidase. *Parasitol. Int.* 51, 195-199, 2002.
 49. Takashima, E., Ken, D., Osanai, A., Nara, T., Odaka, M., Aoki, T., Inaka, K., Haradad, S. and Kita, K. Characterization of the dihydroorotate dehydrogenase as a soluble fumarate reductase in *Trypanosoma cruzi*. *Mol. Biochem. Parasitol.* 122, 189-200, 2002.
 50. Miyadera, H., Shiomi, K., Ui, H., Yamaguchi, Y., Masuma, R., Tomoda, H., Miyoshi, H., Osanai, A., Kita, K. and Omura, H. Atpenins, potent and specific inhibitors of mitochondrial complex II (succinate-ubiquinone oxidoreductase). *Proc. Natl. Acad. Sci. USA*, in press

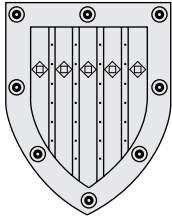

Department of Organ Pathophysiology and Internal Medicine Health Service Center

Outline and Research Objectives

In 1972, Health Service Center was founded under the auspices of the Ministry of Education and Culture to keep sound physical and mental environment in the University of Tokyo. The director of the Center has been elected from a member of Professors in Faculty of Medicine and dealt with two main services, 1) Primary care for undergraduate, graduate and postgraduate students as well as Faculty Staff and 2) Health Control strategy. At the opening of the Center, the main task was restricted to the Student with infectious disease including tuberculosis and malnutrition and medical check of all students in several aspects. The Center has three branch offices, in Hongo, Komaba and Kashiwa Campuses from 2001.

Recently, the number of students in the University is enormously increasing and reached about 25,000. The University also contains Faculty Staffs about 5,000. Target diseases include a wide variety of sickness, ranging from acute but minor problems like common cold, acute gastroenteritis, several accidents during experiment, injuries in sports, insomnia or neurosis to grave or life-threatening sickness such as malignant neoplasms, AIDS, Hepatitis C, imported infections from foreign countries, DMI and suicide. Graduate and Postgraduate Students are actually main human resources to produce the Research output in Laboratory. Their burdened life in both hard works to do until midnight and competitive stress to reach a top-level scientist would cause several serious problems.

Official duties of the Center contain 1) Routine medical care of several problems, 2) Health Check after entrance exam, 3) Regular Health check of all Faculty Members, 4) Regular Health Check for Students from Abroad, 5) Medical Education Programming for chronic diseases, 6) Regular Health Check for Students and Faculty Members treating hazardous materials or radioisotopes, 7) Issue of Health Check Forms, 8) Health Consultation in general, 9) Health Check for the candidates of new staffs and so on.

Faculties and Students

Professor and Chair	Teruhiko TOYO-OKA, M.D., Ph.D. (1991-)
Associate Professors	Yoshio UEHRA, M.D., Ph.D. (1999-) Tsukasa SASAKI, M.D., Ph.D. (2000-)
Lecturers	Shu UWATOKO, M.D., Ph.D. (1997-) Jun-ichi SUZUKI, M.D., Ph.D. (1998-) Takashi ISHIKAWA, M.D., Ph.D. (1998-) Katsuyuki ANDO, M.D., Ph.D. (1997-) Miyuki SADAMATSU, M.D., Ph.D. (2000-) Hisako HIKIJI, M.D., Ph.D. (2001-)
Associates	8

Past Research and Major Accomplishments

From 1976, the author has addressed to the pathophysiology of the most serious and popular problems in medicine in Japan, heart failure. Precise mechanism of the development is still unknown on advanced

heart failure from pressure overload secondary to hypertension, several kinds of valvular stenosis, volume overload due to congenital heart anomaly or valvular insufficiency or from unidentified etiology including idiopathic cardiomyopathy. Based on an exact diagnosis, the treatment should be performed, considering the clinical setting of the patients.

After finishing Ph.D. course in the laboratory of Prof. Setsuro EBASI, who is one of the most outstanding scientists in muscle biology, Dr. Tomoh MASAKI and I have purified calcium- activated neutral protease (CANP or calpain) from cardiac muscle for the first time and characterized both the biochemical and pathological features. Studies on calpain continued when I moved to the Department of Cardiology in San Diego or Physiologisches Institut in Heidelberg where calpain was found to be involved in the loss of myofibrillar proteins in myocardial infarction or platelet aggregation.

Using *in vivo* ^1H and ^{31}P -NMR, the author has indicated structure abnormalities of sarcolemma as the cause for dilated cardiomyopathy (DCM) that is still the most grave and incurable heart failure. The hereditary form of DCM due to gene abnormalities of cardiac actin, dystrophin, several sarcoglycans (SG) and desmin has been reported in human cases. We have discovered gene deletion of δ -SG in human and hamster with hereditary DCM and identified its breakpoint (Sakamoto *et al.*, *Proc.Natl.Acad.Sci.USA* 1997; Tsubata *et al.*, *J.Clin.Invest.* 2000). Comparing with normal control, BIO 14.6 strains that develop DCM following a hypertrophy phase, some, but not all, SGs except δ -SG remained. On the other hand, TO-2 strains, which develop DCM from an early stage, did not express any SG at all (Kawada *et al.*, *FEBS Lett.* 1999). These results indicate the scheme that the integrity of cell membrane is normally preserved when all SG are present, but as demonstrated with BIO 14.6 hamsters, develops compensatory hypertrophy when SG is partially present, and finally reaches advanced heart failure, when all SGs were lost. Results from northern blot analysis confirmed abundant mRNA expression of α -, β -, and γ -SGs, and their promoter structures were preserved. Accordingly, we concluded that the actual cause of DCM is the gene mutation of δ -SG and loss of other SGs were originated from post-translational level.

To modulate translation of specific mRNA to protein, we demonstrated that transgene expression is most effectively inhibited with CMV promoter-activated antisense DNA plasmid, rather than general antisense DNA (Chen *et al.*, *J.Biol.Chem.* 2000; Wang *et al.*, *Circ.Res.*, 2001). In addition, with approval of ethical committee, we conducted genetic diagnosis of mitochondrial cardiomyopathy and identified a novel DCM-linked D-loop (Shin *et al.*, *Am.J.Hum.Genet.*, 2000).

Since the discovery of dystrophin, heart failure due to dystrophin-related proteins (DRP) abnormalities have been regarded as accompanying symptoms of congenital muscular dystrophy. Although there was a report on proteolysis of dystrophin following viral myocarditis, we have reported most cases of acquired DRP disruption observed in chronic heart failure models were caused by the direct degradation of DRP complex including catecholamine toxicity and heart failure of the old myocardial infarction.

To develop gene therapy of advanced heart failure, we employed several vectors. Using proteoliposome, we have transfected eNOS gene to cardiac muscles *in vivo*, and succeeded initiating apoptosis (Kawaguchi *et al.*, *Circulation* 1997). We have also indicated the necessity to employ other vectors for the efficient, long-term, and biologically inert transfection (Kawada *et al.*, *BBRC*, 1999). Our attempt to transduce the

causative gene when it is identified has shown that responsible gene does improve pathophysiology and rescue the hereditary DCM (Kawada *et al.*, *PNAS* 2002).

Current Research

Although the prognosis of advanced heart failure typified by DCM is now gradually improving through various pharmaceutical agents, the final choice is heart transplantation. However, there are still many ethical, social and medical obstacles such as keeping the number of donor hearts, and continuing immunosuppressant therapy after the transplantation during whole life. The development of gene therapy is anticipated as an ideal method to overcome these problems. As a solution for these problems, we proposed the following 3-year-plan to develop new strategy for the prevention and treatment of advanced heart failure (2002 to 2004).

- **Research and Survey Projects in the Ministry of Welfare to investigate the patient population of the mutated gene previously cloned** (2002).
- **Development of new potential gene-delivery system.** Using safe and long-lasting adeno-associated virus (rAAV) as a vector, we previously transferred responsible gene with normal sequence, *via* thoracotomy to above animal model, which improved the prognosis. To examine if this method is clinically applicable to larger subhuman animals, as a step towards clinical use of the basic research, we will conduct preclinical studies on monkeys (2002-2004). Specifically, after initiating large-scale production of rAAV (2002), and simultaneously develop administration methods with high transfection efficiency. (2003)
- **Search for more realistic gene-delivery route.** Clinical situation of the patients with advanced heart failure, however, requires less aggressive route not under open chest surgery. Another administration route via transcortary route might be preferable to attain the efficient and safe delivery (2004).
- **Strict evaluation of safety in regards to general pathology, immunology, and germ-line cell infection.** Trail of the rAAV administration to skeletal muscle cells is similar but more easily transfectable than myocardial cells (2002-2003).
- **Creation of advanced heart failure presenting human-type DCM in larger animals.** Small animal model does not always represent human diseases. Rhesus monkeys will be employed, because the Ministry of Welfare in Japan has accepted this species in a preclinical study (2003). Animal models of human-like DCM will be highly innovative for the development of various disease treatments.

- **Cell transplantation combined with the gene therapy.** Patients seek treatment only when symptoms become severe. Gene therapy was effective to prevent the disease progression but could not regenerate the normal cells. Transduction of normal sequence transgene to cultured muscle cells and create normalized cells *in vitro* might be promising for the patients after the onset of the symptoms. Fortunately, skeletal myoblasts can proliferate and be transplantable to cardiac tissue and show new development of cardiac muscle cells. Transplantation of genetically normalized myoblasts will be promising for the next generation gene therapy.

Future Prospects

Present project consists of two sections, as follows.

- **Double vector strategy for the development of knockout heart and novel therapy with mon-keys.** Previous report that knockout of δ -SG gene in mice caused not only DCM but also coronary spasm (Coral-Vasquez *et al.*, *Cell* 1999). The contribution of myocardial ischemia is of great significance for the pathogenesis of DCM, although they did not show clear evidence to support the scheme. Because of the limitation of handling in small heart, no group has succeeded in the verification of the microvessel spasm. To clarify the contribution of coronary spasm, we are trying to prepare not transgenic mice but knockout heart in large animals like Rhesus, to make it possible to visualize coronary spasm by coronary angiography and anaerobic metabolism as follows. AAV consists of 5 subtypes, Serotype I to V. Preliminary experiment showed that type V was the most efficiently transfected both skeletal and cardiac muscle cells *in vivo*, followed by type III and II. We have been verifying *in vivo* since last year and succeed in modifying the rAAVs for gene vector. The rAAV type II as gene therapy vector, known to be safe and to possess a long expression period. In addition to type II, we have already prepared type V and are now making sure the safety. (2002).

Since the serotype of these rAAV vectors completely differ, mutual interference does not take place. This difference of serotypes has crucial meaning to our study. By applying different rAAV vectors at the initial and secondary administration, different antigenicity does not prevent double transfection. In our present study, we will initially administer rAAV type V that is the most efficient with δ -SG antisense, extensively to monkey cardiac muscle *in vivo*, and create a cardiospecific δ -SG deficient heart. Following

validation of transfection *via* myocardial biopsy using specific antibody to δ -SG, the pathogenesis will be precisely examined whether they develop human-like DCM (2003).

Subsequently, expression of δ -SG containing normal or abnormal sequence can be examined, using rAAV type II. With the former gene, the rescue will be expected, as demonstrated previously with hamsters. With the latter animals, we will confirm the presence of transgene, and examine the persistence of clinical symptoms of dilated cardiomyopathy by physiological examinations by hemodynamics, echocardiography and assay of BNP (2004).

- **Combination therapy of gene and cell therapy at the advanced heart failure.**

Cell therapy will be promising for the treatment of advanced heart failure after progression to the degenerative process of cardiomyocytes. Simple cell transplantation tried in humans is not applicable to the case with gene-deletion or mutation, because intrinsic gene mutation universally occurs in all tissues including cardiac muscle and skeletal muscle. After skeletal myoblasts in culture were proliferated and transfected by normal gene, the treated and normalized muscle cells can be transplanted to DCM heart. For ethical considerations, genetic diagnosis a priori is essential for identifying responsible gene or at least, actually aggravating factor and for developing gene therapy. In accordance with recommendations by Helsinki Declaration, Science Council, Ministry of Education, Ministry of Health and Welfare and related 8 Academic Societies, we requested for a strict inquiry by ethical committee. As stated above, we have already demonstrated serious consideration to privacy protection in our previous study on nation-wide genetic diagnosis survey for the prevention of sudden death and obtained very meaningful results (Shin *et al.*, *Am.J.Hum.Genet.* 2000).

Research Grants from 1998 to 2002.

1998-2000 The Ministry of Education, Culture, Science and Sports; Section A (1), "Novel gene therapy of dilated cardiomyopathy secondary to disruption of dystrophin-related proteins".

1998-2000 The Ministry of Education, Culture, Science and Sports; Section A (2), "Prevention trial of sudden death with using gene-based presymptomatic diagnosis".

2001 Uehara Memorial Foundation, "Development of gene-based therapy for dilated cardiomyopathy".

2002-4 The Ministry of Education, Science, Culture and Sports; Section A (1), "Gene or cell-engineered therapy of advanced heart failure".

2002-4 The Ministry of Health, Labor and Welfare; Translational Research Project from Basic Medicine to

Clinical Therapy, "Clinical application of gene therapy with cell engineering for the treatment of advanced heart failure".

Select Publications

1. Ebashi S, Nonomura Y, Toyo-oka T. and Katayama E. Regulation of muscle contraction by the calcium-troponin-tropomyosin system. Cambridge University Press, *Symposia of the Society for Experimental Biology* 30, 349-360, 1976.
2. Toyo-oka T, Shimizu T. and Masaki T. Inhibition of proteolytic activity of calcium activated neutral protease by leupeptin and antipain. *Biochem.Biophys.Res.Commun.* 82, 484-491, 1978.
3. Toyo-oka T. Increased activity of intramuscular proteases in the hyperthyroid state. *F.E.B.S.Lett.* 117, 122-124, 1980.
4. Toyo-oka T. Calcium ion-insensitive contraction of glycerinated porcine cardiac muscle fibers by Mg-inosine triphosphate. *Circ.Res.* 49, 1350-1355, 1981.
5. Toyo-oka T. and Ross JJ. Ca²⁺ sensitivity change and troponin loss in cardiac natural actomyosin after coronary occlusion. *Am.J.Physiol.* 240, H704-H708, 1981.
6. Toyo-oka T. Phosphorylation with cyclic adenosine 3' 5' monophosphate-dependent protein kinase renders bovine cardiac troponin sensitive to the degradation by calcium-activated neutral protease. *Biochem.Biophys.Res.Commun.* 107, 44-50, 1982.
7. Toyo-oka T, Nagayama K, Umeda M, Eguchi K. and Hosoda S. Rhythmic change of myocardial phosphate metabolite content in cardiac cycle observed by depth-selected and EKG-gated *in vivo* ³¹P-NMR spectroscopy in a whole animal. *Biochem.Biophys.Res.Commun.* 135, 808-815, 1986.
8. Ikeda U, Toyo-oka T. and Hosoda S. Identification of two new calcium dependent hydrolases in the human heart. *Biochem.Biophys.Res.Commun.* 136, 773-777, 1986.
9. Toyo-oka T, Nagayama K, Umeda M, Ogawa S, Eguchi K, Hosoda S. and Sugimoto T. Combined study of ¹H-magnetic resonance imaging and depth-selected, EKG-gated ³¹P-magnetic resonance spectroscopy of the heart *in vivo*. *Biochem.Biophys.Res.Commun.* 144, 841-848, 1987.
10. Toyosaki N, Toyo-oka T, Natsume T, Katsuki T, Tateishi T, Yaginuma T. and Hosoda S. Combination therapy with diltiazem and nifedipine in patients with effort angina pectoris. *Circulation* 77, 1370-1375, 1988.
11. Toyo-oka T. A critical review of NMR imaging and spectroscopy for the evaluation of cardiac hypertrophy in humans and experimental animals. *J.Mol.Cell.Cardiol.* 5, 141-147, 1989.
12. Toyo-oka T, Arisaka H, Sanma H, Shin WS, Dan Y. and Sugimoto T. Synergistic deleterious effect of micromolar Ca ions and free radicals on respiratory function of heart mitochondria at cytochrome C and its salvage trial. *Biochem.Biophys.Res.Commun.* 163, 1397-1403, 1989.
13. Toyo-oka T, Arisaka H, Takayasu T, Tezuka T. and Hosoda S. *In vivo* ³¹P-NMR spectroscopy of heart in hypoxia and identification of biochemical factors responsible for contractility loss. *Prog.Clin.Biol.Res.* 315, 567-579, 1989.
14. Toyo-oka T, Shin WS, Okai Y, Dan Y, Morita M, Iizuka M. and Sugimoto T. Collagen-stimulated human platelet aggregation is mediated by endogenous calcium-activated neutral protease. *Circ.Res.* 64, 407-410, 1989.
15. Takayasu T, Toyo-oka T. and Hosoda S. Waste of ATP for tension development in myocardial acidosis: Chemomechanical uncoupling at myofibrillar level. *J.Mol.Cell.Cardiol.* 22, 127-130, 1990.
16. Naitoh T, Toyo-oka T. and Sugimoto T. An endogenous Ca²⁺ channel agonist, endothelin-1, does not directly activate partially purified dihydropyridine-sensitive Ca²⁺channel from cardiac muscle in a reconstituted system. *Biochem.Biophys.Res.Commun.* 171, 1205-1210, 1990.
17. Okai-Matsuo Y, Takano-Ohmuro H, Toyo-oka T. and Sugimoto T. A novel myosin heavy chain isoform in vascular smooth muscle. *Biochem. Biophys. Res. Commun.* 176, 1365-1370, 1991.
18. Shin WS, Toyo-oka T, Masuo M, Okai Y, Fujita H. and Sugimoto T. Subpopulations of rat vascular smooth muscle cells as discriminated by calcium release mechanisms from internal stores. *Circ.Res.* 69, 551-556, 1991.
19. Masuo M, Toyo-oka T, Shin WS. and Sugimoto T. Growth-dependent alterations of intracellular Ca²⁺-handling mechanisms of vascular smooth muscle cells. *Circ.Res.* 69, 1327-1339, 1991.
20. Suzuki T, Toyo-oka T, Shin WS, and Sugimoto T. Cell growth-dependent expression of endothelin-1 provokable Ca²⁺ channels in cloned vascular smooth muscle cells. *J.Cardiovasc. Pharmacol.* 17 (Suppl. 7), S187-S189, 1991.
21. Toyo-oka T, Aizawa T, Suzuki N, Hirata Y, Miyauchi T, Shin WS, Yanagisawa M, Masaki T. and Sugimoto T. Increased plasma level of endothelin-1 and coronary spasm induction in patients with vasospastic angina pectoris. *Circulation* 83, 476-483, 1991.
22. Toyo-oka T. and Sugimoto T. Endothelin: Key to coronary vasospasm? *Circulation* 84, 1451-1452, 1991.
23. Shin WS, Sasaki T, Kato M, Hara K, Seko A, Yang WD, Shimamoto N, Sugimoto T. and Toyo-oka T. Autocrine and paracrine effects of endothelium-derived relaxing factor on intracellular Ca²⁺ of endothelial cells and vascular smooth muscle cells: Identification by two-dimensional image analysis in coculture. *J.Biol.Chem.* 267, 20377-20382, 1992.
24. Toyo-oka T, Nagayama K, Suzuki J. and Sugimoto T. Noninvasive assessment of cardiomyopathy development with simultaneous measurement of topical ¹H- and ³¹P-magnetic resonance spectroscopy. *Circulation* 86, 295-301, 1992.

25. Toyo-oka T, Wang YP, Inukai M. and Sakamoto A. An endothelin family. Recent Progress in Basic and Clinical Sciences. *Coronary Artery Dis.* 2 (Review in Depth), 65-71, 1993.
26. Sakamoto A, Yanagisawa M, Sawamura T, Enoki T, Ohtani T, Sakurai T, Nakao K, Toyo-oka T. and Masaki T. Distinct subdomains of human endothelin receptors determine their selectivity to endothelin_A-selective antagonist and endothelin_B-selective agonists. *J.Biol.Chem.* 268, 8547-8553, 1993.
27. Yang W, Ando J, Korenaga R, Toyo-oka T. and Kamiya A. Exogenous nitric oxide inhibits proliferation of cultured vascular endothelial cells. *Biochem.Biophys.Res.Comm.* 203, 1160-1167, 1994.
28. Uehara Y, Hirawa N, Kawabata Y, Suzuki T, Ohshima N, Oka K, Ikeda T, Goto A, Toyo-oka T, Kizuki K. Long-term infusion of kallikrein attenuates renal injury in Dahl salt-sensitive rats. *Hypertension* 24, 770-778, 1994.
29. Korenaga R, Ando J, Tsuboi H, Yang W, Sakuma I, Toyo-oka T. and Kamiya A. Laminar flow stimulates ATP- and shear stress-dependent nitric oxide production in cultured bovine endothelial cells. *Biochem.Biophys.Res.Comm.* 198, 213-219, 1994.
30. Sakamoto A, Yanagisawa M, Tsujimoto G, Nakao K, Toyo-oka T. and Masaki T. Pseudo-noncompetitive antagonism by BQ123 of intracellular calcium transients mediated by human ETA endothelin receptor. *Biochem.Biophys.Res.Comm.* 200, 679-686, 1994.
31. Kato M, Takazawa K, Kimura A, Ruegg JC, Amano K, Wang Y, Sakaki Y. and Toyo-oka T. Altered actin binding with myosin mutation in hypertrophic cardiomyopathy and sudden death. *Lancet* 345, 1247, 1995.
32. Shin WS, Kawaguchi H, Sasaki T, Wang YP, Yang WD, Inukai M. and Toyo-oka T.. The role of nitric oxide in cardiovascular system. *Ann.N.Y.Acad.Sci.* 786, 233-244, 1996.
33. Wang YP, Shin WS, Kawaguchi H, Inukai M, Kato M, Sakamoto A, Uehara Y, Miyamoto M, Shimamoto N, Korenaga R, Ando J. and Toyo-oka T. Contribution of sustained Ca²⁺ elevation for nitric oxide production in endothelial cells and subsequent modulation of Ca²⁺ transient in vascular smooth muscle cells in coculture. *J.Biol.Chem.* 271, 5647-5655, 1996.
34. Toyo-oka T. and Naylor WG. Third generation calcium entry blockers. *Blood Pressure* 5, 206-208, 1996.
35. Kawaguchi H, Shin WS, Wang Y, Inukai M, Kato M, Matsuo-Okai Y, Sakamoto A, Kaneda Y, and Toyo-oka T. Apoptosis-like myocardial cell death with overexpression of human eNOS gene-Identification by Sendai virus-coated liposomes and *in vivo* gene transfection-. *Circulation* 95, 2441-2447, 1997.
36. Sakamoto A, Ono K, Abe M, Jasmin G, Eki T, Murakami Y, Masaki T, Toyo-oka T, and Hanaoka, F. Both hypertrophic and dilated cardiomyopathy are caused by mutation of the same gene, δ -sarcoglycan, in hamster. *Proc.Natl.Acad.Sci.USA.* 94, 13873-13878, 1997.
37. Iwasawa K, Nakajima T, Hazama H, Goto A, Shin WS, Toyo-oka T and Omata M. Effects of extracellular pH on receptor-mediated Ca²⁺ influx in A₇₁₅ rat smooth muscle cells. *J.Physiol.* 503, 237-251, 1997.
38. Nagoshi H, Uehara Y, Kanai F, Maeda S, Ogura T, Goto A, Toyo-oka T, Esumi H, Shimizu T and Omata M. Prostaglandin D₂ inhibits inducible nitric oxide synthase expression in rat vascular smooth muscle. *Circ.Res.* 82, 204-209, 1998.
39. Shimamoto R, Suzuki J, Nishikawa J, Fujimori Y, Nakamura F, Shin WS, Tomaru T and Toyo-oka T. Measuring the diameter of coronary arteries on MR angiograms using spatial profile curves. *Am.J.Roent.* 170, 889-893, 1998.
40. Suzuki J-i, Shimamoto R, Nishikawa J, Fujimori Y, Nakamura F, Shin WS, Tomaru T and Toyo-oka T. Vector analysis of the hemodynamics of atherogenesis in the human thoracic aorta with use of MR velocity mapping. *Am.J.Roent.* 171, 1285-1290, 1998.
41. Suzuki J-i, Shimamoto R, Nishikawa J, Yamazaki T, Tsuji T, Nakamura F, Shin WS, Nakajima F, Toyo-oka T, Ohotomo K. Morphological onset and early diagnosis in apical hypertrophic cardiomyopathy: a long-term analysis with nuclear magnetic resonance imaging. *J.Am.Coll.Cardiol.* 33, 146-151, 1999.
42. Kawada T, Shin WS, Nakatsuru Y, Koizumi T, Sakamoto A, Nakajima T, Nakazawa M, Sato H, Takato T, Ishikawa T and Toyo-oka T. Precise identification of gene-products in hearts after *in vivo* gene transfection, using Sendai virus-coated proteoliposomes. *Biochem.Biophys.Res.Comm.* 259, 408-413, 1999.
43. Hirawa N, Uehara Y, Kawabata Y, Numabe A, Gomi T, Ikeda I, Suzuki T, Goto A, Toyo-oka T and Omata M. Long-term inhibition of renin-angiotensin system sustains memory function in aged Dahl rats. *Hypertension* 34, 496-502, 1999.
44. Kawada T, Nakatsuru Y, Sakamoto A, Koizumi T, Shin WS, Okai-Matsuo Y, Suzuki J, Uehara Y, Nakazawa M, Satoh H, Ishikawa T and Toyo-oka T. Strain- and age-dependent loss of sarcoglycan complex in cardiomyopathic hamster hearts and its reexpression by d-sarcoglycan gene transfer *in vivo*. *F.E.B.S.Lett.* 458, 405-408, 1999.
45. Shin WS, Tanaka M, Suzuki J, and Toyo-oka T. A novel homoplasmic mutation in mtDNA with a single evolutionary origin as a risk factor for cardiomyopathy. *Am.J.Hum.Genet.* 67, 1617-1620, 2000.
46. Chen J, Wang YP, Nakajima T, Iwasawa K, Hikiji H, Sunamoto M, Yoshida Y, Sakaki Y, and Toyo-oka T. Autocrine action and its underlying mechanism of nitric oxide on intracellular Ca²⁺ homeostasis in vascular endothelial cells. *J.Biol.Chem.* 275, 28739-28749, 2000.
47. Wang YP, Chen J, Wang Y, Taylor CW, Hirata Y, Hagiwara H, Mikoshiba K, Toyo-oka T, Omata M, and Sakaki Y. Crucial role of type 1, but not type 3, IP₃ receptors in IP₃-induced Ca²⁺ release, capacitative Ca²⁺ entry and proliferation of A₇₁₅ vascular smooth muscle cells. *Circ.Res.* 88, 202-299, 2001.

48. Kawada T, Sakamoto A, Nakazawa M, Urabe M, Masuda F, Hemmi C, Wang Y, Shin WS, Nakatsuru Y, Sato H, Ozawa K and Toyo-oka T. Morphological and physiological restorations of hereditary form of dilated cardiomyopathy by somatic gene therapy. *Biochem.Biophys.Res.Commun.* 284, 431-435, 2001.
49. Shin WS, Hemmi C and Toyo-oka T. Coculture and cross talk between endothelial cells and vascular smooth muscle cells mediated by intracellular Ca^{2+} . *Methods in Molecular Biology*, Ed. C. Wise, Medical Research Council Press (London), 347-357, 2001.
50. Kawada T, Nakazawa M, Nakauchi S, Yamazaki K, Shimamoto R, Urabe M, Nakata J, Hemmi C, Masui F, Nakajima T, Suzuki J, Monahan J, Sato H, Takeo S, Ozawa K and Toyo-oka T. Rescue of hereditary form of dilated cardiomyopathy by rAAV-mediated somatic gene therapy. *Proc.Natl.Acad.Sci.USA.* 99, 901-906, 2002.

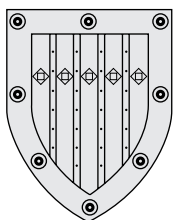

Radiation Research Institute

Outline and Research Objectives

Radiation Research Institute (formerly called as Radioisotope Research Institute) was established in 1992 for the purpose of radiation safety control of five radioisotope research laboratories belonging to Faculty of Medicine. They are located in basic science buildings, Animal Center, University Hospital, and University Branch Hospital. (The laboratory in University Branch Hospital was closed in March, 2002.) The research is also expected to the Institute on the subjects related to radiations and radioisotopes such as radiation biology, medical application of radiations/radioisotopes, and health physics.

Faculties and Students

Professor and Chair	Kunio Shinohara, Dr. of Medical Science (1996-)
Lecturer	Takahiko Suzuki, Dr. of Pharmaceutical Science
Research Student	1

Past Research and Major Accomplishments

I (K. Shinohara) learned applied physics at undergraduate course. After I got masters degree in biophysics, I took a doctoral course in medical science. In the field of radiation biology, I started my research work on the cytotoxic effects of γ -rays on cultured mammalian cells in a colony state that is a model system for tumor cord [1]. Then the subject moved to DNA damage and its repair induced by radiation and radiomimetic chemicals such as methylazoximethanol acetate, an active principle of cycasin which is naturally occurring carcinogen in cycad, and benzo(a)pyrene. When new radiation source, synchrotron radiation, became available, our research subjects shifted to focus on biological/medical application of monochromatic X-rays such as Auger enhancement of radiation-induced cell death and development and application of soft X-ray microscopy. In the mean time we found that to image hydrated specimens by soft X-ray microscopy at high resolution, we need intense X-ray source to image at a shorter time than the movement by Brownian motion. For this purpose, we applied laser-produced plasma X-rays, by which the exposure time was as short as 300 psec.

1. DNA damage and its repair induced by radiation and radiomimetic chemicals

With the aid of caffeine, we found that methylazoxymethanol acetate induces damage, which is repaired by a mechanism analogous to post-replication repair of UV light-induced damage [3]. In this

study, we used synchronized cells obtained by the automatic synchronizer which we developed [2].

In the study of another carcinogen, benzo(a)pyrene, we detected the formation and excision repair of benzo(a)pyrene-DNA adducts in mammalian cells [4, 6]. This adducts were also detected in peripheral human lung tissue when the tissue was cultured in the presence of benzo(a)pyrene [5].

It is also observed that depression level of DNA synthesis is well correlated to the sensitivity of cell death to UV-irradiation in normal human cells and in cells derived from xeroderma pigmentosum patient deficient in DNA repair [8].

2. Radiation- and heat-induced cell death

(1) Heat-induced cell death

Hyperthermia is developed as one of the method for cancer treatment. The sensitivity of cell death induced by the heat-treatment was studied with respect to energy metabolism. It has been demonstrated that when the synthesis of ATP is inhibited, sensitivity of the cell to heat increases [16]. Our results show that ATP level decreases after heat-treatment and in a treatment-time dependent manner [15]. The sensitivity of cells to heat is well correlated to the ATP level of the cells at normal growth condition which corresponds to the pool size of ATP (or potential to synthesize ATP) [26,49]. The results indicate that energy metabolism is a good marker to evaluate heat sensitivity. We also observed that Ga citrate, a tumor-seeking compound, is a good sensitizer to heat treatment [17,47].

(2) Studies on radiation-induced cell death

X-rays inhibit DNA synthesis. Initiation of DNA synthesis is much more sensitive to X-rays than its elongation. We studied carefully this inhibition and resumption of replicon initiation after X-irradiation [7].

Synchrotron radiation is an intense radiation,

intense enough to study the effects of monochromatic X-rays. We first studied an action spectrum of lethal effects on mammalian cells in the wavelength range from 160 to 254 nm. Cells were sensitive to 160 nm and 254 nm and relatively resistant to 190 nm [9]. We found that target site was not DNA but membrane at the wavelength of 160 nm [13].

(3) Auger enhancement

When elements absorb X-rays at the inner shell electrons, they release Auger electrons and are highly toxic. Their LET corresponds to 5 MeV α particles (100 keV/ μ m). Therefore, efficient induction of Auger effects in cells by X-rays will result in the sensitization to the cells. We studied this enhancement by labeling the cells with 5-bromodeoxyuridine or 5-iododeoxyuridine and monochromatic synchrotron radiations at the wavelengths slightly higher than K absorption edges of these elements (i.e., Br and I). Our results are the first data for the Auger enhancement of cytotoxicity on mammalian cells obtained by synchrotron radiation [10,11]. Auger enhancement is also observed in the induction of chromosome aberration [18]. Theoretical reports pointed the great enhancement and suggested the new possible modality for radiation therapy. However, our experimental results were not in accord with this theory [11]. We re-evaluated this theoretical consideration and found that the theory needs correction. Our correction of the theory fits well to the experimental data [14]. This report [14] is cited in News and Views in Nature by John Humm (336, 710-711, 1988). The results were against the expectation for radiation therapy, but this is science. In the same issue of Nature, another method of Auger enhancement was reported. The method based on the nuclear resonance absorption of the element. Although the results presented in the report could have not been confirmed yet, the idea is attractive. We estimated the enhancement ratio using the same equation as above and found that more than 10 times higher enhancement will be expectable [unpublished results]. However, it is hard to obtain the experimental data to evaluate this theoretical estimate at the present stage. To keep the potential to study Auger enhancement, we tried to detect and characterize Auger enhancement using laboratory X-ray source. We observed small fraction of Auger enhancement that was protectable by cysteamine as a proton donor for radiation damage [41]. We also studied suicide experiment with a radioisotope of iodine-125 [28].

(4) Molecular mechanisms of radiation-induced cell death

Radiation-induced cell death has been classified into two groups: reproductive death and interphase death. Reproductive death is determined by the

colony forming ability, while interphase death is thought to be functional loss and estimated by loss of membrane function (as demonstrated by the dye exclusion test) or energy metabolism. We first studied the difference in these two modes of cell death. For this purpose human leukemic MOLT-4 cells are well suited. They show interphase death at relatively low dose irradiation and also are able to be determined for the colony forming ability. The data [29] show that both types of cell death occur in MOLT-4 cells and that the mechanism of cell death is apoptosis. Next, we compared MOLT-4 with M10, which is a radiosensitive mutant of L5178Y derived from mouse lymphocytic leukemia and has the same level of radiosensitivity. Unexpectedly, we found that M10 developed necrosis, while MOLT-4 died by apoptosis at the same dose level of irradiation [31]. It is confirmed with the heat-treatment that M10 has a system to induce apoptosis (, which is not working at X-irradiation,) probably by the different mechanism from MOLT-4 [31,42].

Based on these results, we are interested in the molecular mechanisms of radiation-induced apoptosis (MOLT-4) and necrosis (M10). Now we are focused on the apoptosis in MOLT-4 cells. (Because of the lack of manpower, radiation-induced necrosis in M10 is remained to be studied in future.) Radiation-induced apoptosis in MOLT-4 cells is p53 dependent [45,48] and caspase-3 dependent [50]. It should be noted that inhibition of proteasome also induced apoptosis in MOLT-4 cells probably with the different mechanism from X-rays because both apoptosis were additive [39].

3. Development and application of soft X-ray microscopy

Soft X-rays in a wavelength range of 1-10 nm are provided by synchrotron radiation and moderately absorbed by biological materials. Soft X-ray microscopy has following advantages over optical and electron microscopy: higher penetration depth than electron microscopy and higher resolution than optical microscopy. Therefore, with soft X-ray microscopy, it is expected that we can observe a whole live cell at higher resolution than optical microscopy. When we started this project, there was no soft X-ray microscope. And now, internationally, there are some microscopes with the potential to image at a resolution of 20 nm. However, unfortunately, no active microscope at high resolution has been working in Japan. This is the present stage. More than 15 years ago, we were interested in soft X-ray microscopy and started to study the importance of this new method in biology.

When we started, the only method available for experimental test was a contact microscopy using a

thin film of polymethylmetacrylate (PMMA) that is developed and characterized by IBM for industrial purpose. We studied and applied it for imaging human cells and chromosomes with some improvement of the method for the observation of PMMA by a transmission electron microscope [12]. We have succeeded in the observation of chromosome fibers and nucleosomes [19-21,33]. The results (Fig. 1) were top data with respect to the resolution to image biologically meaningful specimen and were cited in books from USA, China and Japan. Then we studied the condition to image hydrated biological specimens including the problem of radiation damage and image blurring by Brownian motion [22,24,25]. The conclusion of this study proposed the use of short pulsed X-rays for imaging intact specimens in hydrated condition with successful results for hydrated chromosomes with a single shot exposure of laser-produced plasma X-rays at the exposure time of 300 picoseconds [23,30,32]. However, our results were obtained by contact microscopy and the method is good for molecules but not well suited for imaging inside a whole cell. Therefore, we proposed a possible microscope system to image whole cells [27]. The system is now in the stage of development by other groups.

Another important factor for the application of soft X-ray microscopy to biological/medical science is the contrast of the images for thick specimens. To overcome this problem, specific staining with three-dimensional observation may be the best choice. In the case of soft X-rays, there is another possibility to identify elements and molecules: spectroscopic analysis of imaging (spectromicroscopy). We have been working on spectromicroscopy in two aspects: instrumentation [43,44,46] and application [34,37]. This line of work is in progress. For three-dimensional imaging, we have also studied on holographic microscopy

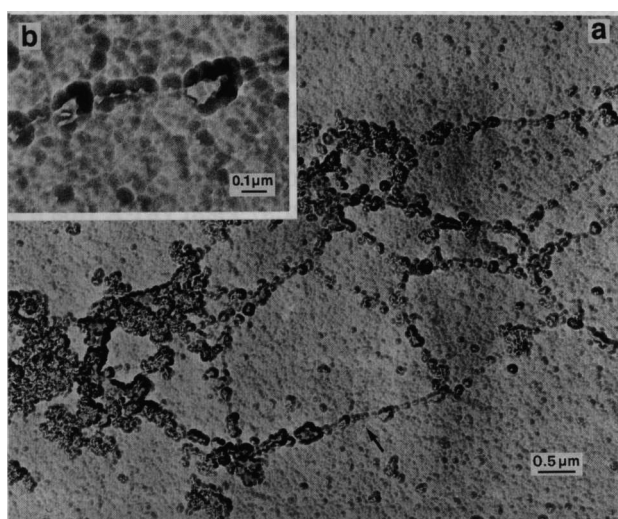

Fig. 1. X-ray image of a stretched portion of a human chromosome [21]. An enlargement of the area indicated by an arrow in (a) is presented in (b).

[35,36,38,40] and found that even with holographic observation, three dimensional reconstruction may not be possible with a single exposure.

Current Research

1. Radiation-induced cell death

(1) Molecular mechanisms of radiation-induced apoptosis

Our present study is focussed on the switching mechanism of p53 to select DNA repair or to decide suicide. For this study we are currently collecting the data for p53, and related molecules and phenomena in each single cell to get the idea what is going on in an individual single cell.

(2) Auger enhancement

As shown above, theoretical consideration shows that Auger enhancement following nuclear resonance absorption is an attractive method. Although we have an idea to evaluate the theoretical results experimentally, we have no clue to apply this method for clinical tumor therapy. Therefore, the work remains in theoretical level at the present stage.

(3) Cytotoxic effects of ultrahigh dose rate X-rays

Time scale of radiation effects on life begins with physical interaction (10^{-18} - 10^{-15} sec) followed by chemical and biological processes. At a conventional method of X-irradiation, these physical and chemical processes will happen dispersively and induce ionization as one after another. In contrast, particle beam densely ionizes irradiated materials and gives increased cytotoxicity to cells. It is of interest to see what will happen if one can concentrate ionization by X-rays in a short instance especially in shorter than one picosecond. Since such a radiation source is available in recent years, we started to study the cytotoxic effects of ultrahigh dose rate X-rays on mammalian cells at the Institute of Laser Engineering, Osaka University. Because of limited beam time, we are gradually correcting results and have no publication so far, though five years have already passed.

2. Development and application of soft X-ray microscopy

Currently our subject is focussed on spectromicroscopy of the cell to understand images for the improvement of contrast. We have collected images of a cell at various wavelengths in a wide range (1-10 nm). With absorption characteristics of elements and molecules, we are trying to identify these elements and molecules using computer-assisted image process-

ing. The work is in collaboration with Prof. Ito of School of Engineering, Tokai University.

Future Prospects

1. Radiation-induced cell death

(1) Auger enhancement

It is not clear that Auger enhancement can be applied for radiation therapy. However, I believe it is worth to continue studying.

(2) Ultrahigh dose rate X-rays in biology and medicine

The new radiation source may be a useful method for discovering the new mode of diagnostics and radiation therapy. At present the work is in the beginning stage. We will keep working on it.

(3) Molecular mechanisms of radiation-induced apoptosis and necrosis

We are planning to understand the full scheme of the flow of signal transduction process in an individual cell from DNA damage induced by X-rays to the development of apoptosis. The results will contribute to understand the whole scheme of apoptosis and to explore the new mode of radiation therapy with the induction of apoptosis.

2. Soft X-ray microscopy

We believe that soft X-ray microscopy will be established and applied to biological/medical research as a complementary method to optical and electron microscopy in future. The system will become compact and stay in laboratory in the size comparable to a transmission electron microscope.

Research Grants

1. Grant-in-Aid for Scientific Research (B) (1) [2001-2003] Studies on biological effects of ultrahigh dose rate pulsed X-rays.
2. Grant-in-Aid for Scientific Research (A) (1) [1997-2000] Development and its medical/biological application of a projection X-ray microscope using synchrotron radiation.
3. Grant-in-Aid for Exploratory Research [1997-1998] Studies on cytotoxic effects of ultrahigh dose rate X-rays.
4. Grant-in-Aid for Scientific Research (A) (1) [1995-1997] High resolution imaging analysis of elements and molecules in a cell with an X-ray contact microscope.

Select Publications

1. Shinohara, K. and Okada, S.: Radiosensitivities of murine lymphoma L5178Y cells in a multi-cellular colony system. *J. Radiat. Res.* 13, 109-116, 1972.
2. Okada, S. and Shinohara, K.: An automatic synchronizer for suspension culture of L5178Y cells. *Cell Tissue Kinet.* 7, 195-199, 1974.
3. Shinohara, K. and Matsudaira H.: Evidence for caffeine-sensitive damage in methylazoxymethanol acetate-treated L5178Y cells. *Chem.-Biol. Interactions* 12, 53-63, 1976.
4. Shinohara, K. and Cerutti, P.A.: Excision repair of benzo(a)pyrene-deoxyguanosine adducts in baby hamster kidney 21/C13 cells and in secondary mouse embryo fibroblasts C57BL/6J. *Proc. Nat'l. Acad. Sci. USA* 74, 979-983, 1977.
5. Shinohara, K. and Cerutti, P.A.: Formation of benzo(a)pyrene-DNA adducts in peripheral human lung tissue. *Cancer Letters* 3, 303-309, 1977.
6. Feldman, G., Remsen, J., Shinohara, K. and Cerutti, P.A.: Excisability and persistence of benzo(a)pyrene DNA adducts in epithelioid human lung cells. *Nature* 274, 796-798, 1978.
7. Shinohara, K. and Watanabe, I.: Inhibition and resumption of replicon initiation in X-irradiated mouse L5178Y cells. *Radiat. Environ. Biophys.* 21, 163-173, 1983.
8. Shinohara, K.: Lethality and the depression of DNA synthesis in UV-irradiated normal human and xeroderma pigmentosum cells. *Mutation Res.* 122, 385-389, 1983.
9. Shinohara, K., Ito, T., Ito, A., Hieda, K., Kobayashi, K. and Okada, S.: An approach to the use of synchrotron radiation for investigating radiation effects on cultured mammalian cells in the range from 160 to 254 nm. *Radiat. Res.* 97, 211-215, 1984.
10. Shinohara, K., Ohara, H., Kobayashi, K., Maezawa, H., Hieda, K., Okada, S. and Ito, T.: Enhanced killing of HeLa cells pre-labeled with 5-bromodeoxyuridine by monochromatic synchrotron radiation at 0.9 Å: An evidence for Auger enhancement in mammalian cells. *J. Radiat. Res.* 26, 334-338, 1985.
11. Shinohara, K., Ohara, H., Hiraoka, T., Nakano, H. and Ando, M.: Irradiation of cultured mammalian cells labeled with iododeoxyuridine by monochromatic synchrotron radiation at 0.370 and 0.380 Å. *Photon Factory Activity Report 1984/85, National Laboratory for High Energy Physics*, p. VI-153, 1986.
12. Shinohara, K., Aoki, S., Yanagihara, M., Yagishita, A., Iguchi, Y. and Tanaka, A.: A new approach to the observation of the resist in X-ray contact microscopy. *Photochem. Photobiol.* 44, 401-403, 1986.
13. Shinohara, K., Ito, A. and Ito, T.: Cell surface damage in cultured mammalian cells with synchrotron radiation at 160 nm. *Photochem. Photobiol.* 44, 405-407, 1986.
14. Shinohara, K., Nakano, H., Hiraoka, T. and Ohara, H.: Re-evaluation of the theoretical study of photon

- activation therapy. Photon Factory Activity Report 1986, National Laboratory for High Energy Physics, p. 278, 1987.
15. Shinohara, K., Kugotani, M., Ishiwata, J. and Matsuda, T.: Early change of adenosine triphosphate levels in L5178Y cells during hyperthermia. *Jpn. J. Cancer Res. (Gann)* 78, 333-335, 1987.
 16. Shinohara, K. and Matsuda, T.: Hyperthermia and cellular ATP levels. *Radiosensitization Newsletter* 6, 9-10, 1987.
 17. Shinohara, K., Kawakami, N., Kugotani, M. and Nakano, H.: Gallium citrate, a new sensitizer of cells to hyperthermia. *Jpn. J. Cancer Res. (Gann)* 79, 21-23, 1988.
 18. Ohara, H., Shinohara, K., Kobayashi, K. and Ito, T.: An additional enhancement in BrdU-labelled cultured mammalian cells with monoenergetic synchrotron radiation at 0.09 nm: Auger effect in mammalian cells. In "DNA Damage by Auger Emitters" (Ed. by K. F. Baverstock and D. E. Charlton), Taylor & Francis, pp. 123-133, 1988.
 19. Shinohara, K.: Observation of human chromosomes with soft X-ray contact microscopy. *SPIE* 1140, 196-200, 1989.
 20. Shinohara, K.: Application of X-ray microscopy to mammalian cells. In "X-Ray Microscopy in Biology and Medicine" (Ed. by Kunio Shinohara, Hiroshi Kihara, Takuma Saito and Keiji Yada), Japan Scientific Societies Press/Springer-Verlag, pp. 203-212, 1990.
 21. Shinohara, K., Nakano, H., Kinjo, Y. and Watanabe, M.: Fine structure of unstained human chromosome fibres dried with no fixative as observed by X-ray contact microscopy. *J. Microscopy* 158, 335-342, 1990.
 22. Shinohara, K. and Ito, A.: Radiation damage in soft X-ray microscopy of live mammalian cells. *J. Microscopy* 161, 463-472, 1991.
 23. Shinohara, K., Ito, A., Kinjo, Y., Watanabe, M., Kikuchi, Y. and Tanaka, K.A.: A simple chamber for hydrated specimen in a vacuum and its application to X-ray contact microscopy with laser produced plasma X-rays. In "X-RAY MICROSCOPY III" (Ed. by A. Michette, G. Morrison and C. Buckley), Springer Series in Optical Sciences Vol. 67, Springer-Verlag, pp. 347-349, 1992.
 24. Shinohara, K. and Ito, A.: Factors affecting the observation of hydrated mammalian cells by soft X-ray microscopy. In "X-RAY MICROSCOPY III" (Ed. by A. Michette, G. Morrison and C. Buckley), Springer Series in Optical Sciences Vol. 67, Springer-Verlag, pp. 397-399, 1992.
 25. Ito, A. and Shinohara, K.: Image blurring by thermal diffusion in the observation of hydrated biomolecules with soft X-ray microscopy. *Cell Structure and Function* 17, 209-212, 1992.
 26. Shinohara, K., Kawakami, N., Ito, A., Kugotani, M., Nakano, H., Ishiwata, J. and Matsuda, T.: The role of ATP metabolism in hyperthermic cell killing. In "Cancer Treatment by Hyperthermia, Radiation and Drugs" (Ed. by T. Matsuda), Taylor and Francis, pp. 79-91, 1993.
 27. Richardson, M., Shinohara, K., Kinjo, Y., Tanaka, K.A., Ikeda, H. and Kado, M.: Pulsed X-ray microscopy of biological specimens with laser plasma source. *SPIE* 1741, 133-141, 1993.
 28. Miyazaki, N. and Shinohara, K.: Cell killing induced by decay of ^{125}I during the cell cycle: comparison of ^{125}I -antipyrine with ^{125}I -bovine serum albumin. *Radiat. Res.* 133, 182-186, 1993.
 29. Shinohara, K. and Nakano, H.: Interphase death and reproductive death in X-irradiated MOLT-4 cells. *Radiat. Res.* 135, 197-205, 1993.
 30. Shinohara, K., Ito, A. and Kinjo, Y.: X-ray microscopy of biological specimens with laser plasma X-rays. *SPIE* 2015, 10-19, 1994.
 31. Nakano, H. and Shinohara, K.: X-ray-induced cell death: apoptosis and necrosis. *Radiat. Res.* 140, 1-9, 1994.
 32. Kinjo, Y., Shinohara, K., Ito, A., Nakano, H., Watanabe, M., Horiike, Y., Kikuchi, Y., Richardson, M.C. and Tanaka, K.A.: Direct imaging in a water layer of human chromosome fibres composed of nucleosomes and their higher-order structures by laser plasma X-ray contact microscopy. *J. Microscopy* 176, 63-74, 1994.
 33. Shinohara, K., Yada, K. and Kinjo, Y.: X-ray microscopy of chromosome structures. In "X-ray Microscopy IV" (Ed. by A. I. Erko and V. V. Aristov), Bogorodskii Pechatnik Publishing Company, pp. 213-216, 1994.
 34. Shinohara, K., Ito, A., Matsumura, T., Kinoshita, K. and Kobayashi, K.: Absorption spectra at the wavelength range of 1.5-10 nm and element-imaging of cultured mammalian cells with electronic zooming tube. In "X-ray Microscopy IV" (Ed. by A. I. Erko and V. V. Aristov), Bogorodskii Pechatnik Publishing Company, pp. 264-267, 1994.
 35. Daido, H., Schulz, M.S., Murai, K., Kodama, R., Yuan, G., Goto, J., Tanaka, K.A., Kato, Y., Nakai, S., Shinohara, K., Honda, T., Kodama, I., Iwasaki, H., Yshinobu, T., Tsukamoto, M., Niibe, M., Fukuda, Y., Neely, D., MacPhee, A. and Slark, G.: Subnano-second in-line soft X-ray holography using germanium laser in the 20 nm wavelength region. *J. X-ray Sci. Technol.* 5, 105-120, 1995.
 36. Shinohara, K., Ito, A., Nakano, H., Kodama, I., Honda, T., Matsumura, T. and Kinoshita, K.: X-ray holographic microscopy of biological specimens with an electronic zooming tube. *J. Synchrotron Radiat.* 3, 35-40, 1996.
 37. Ito, A., Shinohara, K., Nakano, H., Matsumura, T. and Kinoshita, K.: Measurement of soft X-ray absorption spectra and elemental analysis in local regions of mammalian cells using an electronic zooming tube. *J. Microscopy* 181, 54-60, 1996.
 38. Kodama, I., Yamaguchi, M., Ohyama, N., Honda, T., Shinohara, K., Ito, A., T., Matsumura, T., Kinoshita, K. and Yada, K.: Image reconstruction from an in-line

- X-ray hologram with intensity distribution constraint. *Optics Commun.* 125, 36-42, 1996.
39. Shinohara, K., Tomioka, M., Nakano, H., Toné, S., Ito, H. and Kawashima, S.: Apoptosis induction resulting from proteasome inhibition. *Biochem. J.* 317, 385-388, 1996.
 40. Shinohara, K.: Possible applications of X-ray lasers in biology: X-ray microscopy and X-ray lasers. In "X-ray Lasers 1996" (Ed. by S. Svanberg and C.-G. Wahlstrom), Institute of Physics Conference Series Number 151, Institute of Physics, pp. 533-538, 1996.
 41. Shinohara, K., Nakano, H. and Ohara, H.: Detection of Auger enhancement induced in HeLa cells labeled with iododeoxyuridine and irradiated with 150 kV X-rays: Effects of cysteamine and dimethylsulfoxide. *Acta Oncologica* 35, 869-875, 1996.
 42. Nakano, H., Kurihara, K., Okamoto, M., Toné, S. and Shinohara, K.: Heat-induced apoptosis and p53 in cultured mammalian cells. *Int. J. Radiat. Biol.* 71, 519-529, 1997.
 43. Ito, A., Shinohara, K., Mizukami, Y., Nakano, H., Yada, K., Uehara, T. and Honda, T.: X-ray contact microscopy system for spectromicroscopy of biological specimens. *J. Synchrotron Radiat.* 5, 1099-1101, 1998.
 44. Shinohara, K., Ito, A., Nakano, H., Honda, T. and Yada, K.: X-ray microscopy system with an electronic zooming tube. In "X-Ray Microscopy and Spectromicroscopy" (Ed. by J. Thieme, G. Schmahl, E. Umbach and D. Rudolph), Springer-Verlag, pp. I-169-I-173, 1998.
 45. Nakano, H. and Shinohara, K.: Correlation between unirradiated cell TP53 protein levels and radiosensitivity in MOLT-4 cells. *Radiat. Res.* 151, 686-693, 1999.
 46. Shinohara, K., Ito, A., Honda, T., Yoshimura, H. and Yada, K.: Development of an X-ray projection microscope using synchrotron radiation. In "X-Ray Microscopy: Proceedings of the Sixth International Conference" (Ed. by W. Meyer-Ilse, T. Warwick, and D. Attwood), AIP Conference Proceedings 507, American Institute of Physics, pp. 346-349, 2000.
 47. Miyazaki, N., Nakano, H., Kawakami, N., Kugotani, M., Nishihara, K., Aoki, Y. and Shinohara, K.: Sensitizing effects of gallium citrate on hyperthermic cell killing *in vitro*. *Int. J. Hyperthermia* 16, 457-470, 2000.
 48. Nakano, H., Kohara, M. and Shinohara, K.: Evaluation of the relative contribution of a p53-mediated pathway in X-ray-induced apoptosis in MOLT-4 cells by transfection with mutant p53 gene at different expression levels. *Cell Tissue Res.* 306, 101-106, 2001.
 49. Miyazaki, N., Kurihara, K., Nakano, H. and Shinohara, K.: Role of ATP in the sensitivity to heat and the induction of apoptosis in mammalian cells. *Int. J. Hyperthermia* 18, 316-331, 2002.
 50. Nakano, H. and Shinohara, K.: Time sequence analysis of caspase-3-independent programmed cell death and apoptosis in X-irradiated human leukemic MOLT-4 cells. *Cell Tissue Res.* 310, 305-311, 2002.